

# Technical Information Handbook

Wire and Cable

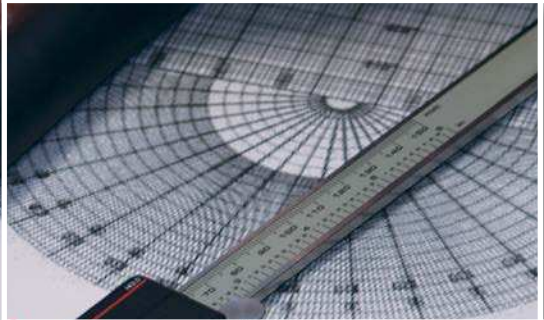

Products • Technology • Services • Delivered Globally •

**ANIXER**

We are a leading global supplier of communications and security products, electrical and electronic wire and cable, fasteners, and other small components. We help our customers specify solutions and make informed purchasing decisions around technology, applications and relevant standards. Throughout the world, we provide innovative supply chain management solutions to reduce our customers' total cost of production and implementation.

Copyright by Anixter. 2301 Patriot Blvd. Glenview, Illinois. 60026.  
No part of the publication may be reproduced without express permission of Anixter.

Anixter Inc. does not manufacture the items described in this publication. All applicable warranties are provided by the manufacturers. Purchasers are requested to determine directly from the manufacturers the applicable product warranties and limitations. Data and suggestions made in the publication are not to be construed as recommendations or authorizations to use any products in violation of any government law or regulation relating to any material or its use.

All due concern has been devoted to accuracy, but Anixter cannot be responsible for errors, omissions or obsolescence. All data herein are subject to change without notice.

**Fifth Edition**

**Copyright © 2013**

**ISBN: 978-0-615-24926-1**

# Technical Information Handbook

Wire and Cable

Fifth Edition Copyright © 2013

Products. Technology. Services. Delivered Globally.

**ANIXER**

The following registered trademarks appear in this handbook:

Alumel® is a registered trademark of Concept Alloys, LLC  
Chromel® is a registered trademark of Concept Alloys, LLC  
Copperweld® is a registered trademark of Copperweld Steel Company  
CSA® is a registered trademark of the Canadian Standards Association  
CCW® is a registered trademark of General Cable Corporation  
DataTwist® is a registered trademark of Belden  
Duofoil® is a registered trademark of Belden  
Flamarrest® is a registered trademark of Belden  
Halar® is a registered trademark of Solvay Solexis  
Hypalon® is a registered trademark of E. I. DuPont de Nemours & Company  
Hypot® is a registered trademark of Associated Research, Inc.  
IBM® is a registered trademark of International Business Machines Corporation  
Kapton® is a registered trademark of E. I. DuPont de Nemours & Company  
Kevlar® is a registered trademark of E. I. DuPont de Nemours & Company  
K FIBER® is a registered trademark of General Cable Corporation  
Kynar® is a registered trademark of Arkema, Inc.  
Loc-Trac® is a registered trademark of Alpha Wire  
Megger® is a registered trademark of Megger Group Ltd.  
Mylar® is a registered trademark of E. I. DuPont de Nemours & Company  
NEC® is a registered trademark of the National Fire Protection Association  
Nicrosil® is a registered trademark of Harrison Alloys, Inc.  
Nisil® is a registered trademark of Harrison Alloys, Inc.  
Nomex® is a registered trademark of E. I. DuPont de Nemours & Company  
Polywater® is a registered trademark of American Polywater Corporation  
Scotch® is a registered trademark of 3M  
Scotchlok® is a registered trademark of 3M  
Solef® is a registered trademark of Solvay Solexis  
Teflon® is a registered trademark of E. I. DuPont de Nemours & Company  
Tefzel® is a registered trademark of E. I. DuPont de Nemours & Company  
Tyrin™ is a trademark of Dow Chemical Company  
UL® is a registered trademark of Underwriters Laboratories, Inc.  
UniBlend® is a registered trademark of General Cable Corporation  
UniShield® is a registered trademark of General Cable Corporation  
UniStrand® is a registered trademark of Belden Inc.  
Valox® is a registered trademark of General Electric Company  
Z-Fold® is a registered trademark of Belden  
Zytel® is a registered trademark of E. I. DuPont de Nemours & Company

Information in this handbook has been drawn from many publications of the leading wire and cable companies in the industry and authoritative sources in their latest available editions. Some of these include:

- American Society for Testing and Materials (ASTM)
- Canadian Standards Association (CSA)
- Institute of Electrical and Electronics Engineers (IEEE)
- Insulated Cable Engineers Association (ICEA)
- International Electrotechnical Commission (IEC)
- National Electrical Manufacturers Association (NEMA)
- National Fire Protection Association (NFPA)
- Naval Ship Engineering Center (NAVSEC)
- Telecommunications Industry Association (TIA)
- Underwriters Laboratories (UL).

Note: National Electrical Code (NEC) is a registered trademark of the National Fire Protection Association, Quincy, MA. The term, National Electrical Code, as used herein, means the triennial publication constituting the National Electrical Code and is used with permission of the National Fire Protection Association.

The Anixter Wire and Cable Technical Handbook is an easily accessible collection of engineering and technical information about electrical and electronic cable and their related products. Primarily intended for individuals who design, specify or troubleshoot wire and cable systems, the Anixter Wire and Cable Technical Information Handbook contains information about topics such as:

- Basic principles of electricity
- Conductor, insulation and jacket materials along with their electrical and mechanical properties
- Cable types, selection criteria and application guidelines for electrical and optical wire and cable
- Installation and testing guidelines and recommendations
- Application tips for cable accessories such as connectors, lugs and terminations
- Packaging, handling and shipping guidelines
- References to hundreds of key domestic and international wire and cable standards
- Conversion tables (e.g., AWG to mm<sup>2</sup>) and basic engineering equations used in the industry

The information contained in this handbook will assist engineers and individuals in designing and constructing safe, reliable, cost-effective and environmentally responsible electrical and communications networks.

Anixter wishes to acknowledge the contributions of the many individuals who assisted in the preparation of this edition of the handbook. Anixter especially wants to recognize the efforts of Deborah Altman, Dana Anderson, Harmony Merwitz, Eric Bulington, Mark Fordham, Jeff Gronemeyer, Andy Jimenez, Jason Kreke, Jonathan Meyer, Nader Moubed, Ania Ross, Eric Wall and Bill Wilkens.

Anixter hopes it has succeeded in making this handbook the best in the industry and welcomes your comments and suggestions for improvements in future editions. If you are interested in downloading the PDF version of this book, please visit [anixter.com](http://anixter.com).

## ABOUT ANIXTER

---

Anixter is a leading global supplier of communications and security products, electrical and electronic wire and cable, fasteners and other small components. We help our customers specify solutions and make informed purchasing decisions around technology, applications and relevant standards. Throughout the world, we provide innovative supply chain management solutions to reduce our customers' total cost of production and implementation.



# CONTENTS

<b>Trademarks and Reference Information</b>	<b>II</b>
<b>Preface</b>	<b>III</b>
<b>About Anixter</b>	<b>III</b>
<b>1. Basic Principles of Electricity</b>	<b>1</b>
1.1 Electricity	2
1.2 The Volt	2
1.3 The Ampere	2
1.4 The Ohm	2
1.5 Ohm's Law	2
1.6 Ampacity	2
1.7 Electrical Systems	3
<b>2. Conductors</b>	<b>5</b>
2.1 Strand Types	7
2.2 Coatings	10
2.3 Tensile Strength of Copper Wire	10
2.4 Copper Strand Properties	11
2.5 Aluminum Strand Properties	22
2.6 Additional Conductor Properties	26
<b>3. Insulation and Jacket Materials</b>	<b>33</b>
3.1 Purpose	34
3.2 Types and Applications	34
3.3 Color Coding	38
3.4 Properties	47

<b>4.</b>	<b>Shields</b>	<b>55</b>
4.1	Power Cable	56
4.2	Electronic Cable	58
<b>5.</b>	<b>Armor</b>	<b>61</b>
5.1	Interlocked Armor	62
5.2	Continuously Corrugated and Welded (CCW)	62
5.3	Basket-Weave	63
5.4	Lead Sheath	63
5.5	Wire Serve	63
<b>6.</b>	<b>Cable Types and Selection Criteria</b>	<b>65</b>
6.1	Portable Power and Control	67
6.2	Construction and Building Wire	68
6.3	Control, Instrumentation and Thermocouple	68
6.4	High Temperature	70
6.5	Power	71
6.6	Armored Power and Control	73
6.7	Electronic Cable	73
6.8	Telephone	78
6.9	Military	80
6.10	Shipboard Cables (MIL-DTL-24643, MIL-DTL-24640 and MIL-DTL-915)	81
6.11	Optical Fiber Cables	81
6.12	Tray Cables	84
<b>7.</b>	<b>Electrical Characteristics</b>	<b>85</b>
7.1	DC Resistance of Plated Copper Conductors	86
7.2	DC and AC Resistance of Copper Conductors	89
7.3	DC and AC Resistance of Aluminum Conductors	91
7.4	Reactance and Impedance at 60 Hz	92
7.5	AC/DC Resistance Ratio at 60 Hz	93
7.6	Temperature Correction Factors for Resistance	94
7.7	Voltage Drop	95
7.8	Maximum Conductor Short Circuit Current	96
7.9	Maximum Shield Short Circuit Current	99
7.10	Resistance and Ampacity at 400 and 800 Hz	100
7.11	Current Ratings for Electronic Cables	101
7.12	Ampacity of Power Cables	102
7.13	Basic Impulse Level (BIL) Ratings	102



---

<b>8.</b>	<b>Installation and Testing</b>	<b>103</b>
	8.1 Receiving, Handling and Storage	105
	8.2 Conduit Fill	106
	8.3 Pulling	111
	8.4 Installation Methods	116
	8.5 Overhead Messengers	119
	8.6 Vertical Suspension	121
	8.7 Hipot Testing	122
	8.8 Fault Locating	124
	8.9 Megger Testing	125
	8.10 Moisture Removal	126
	8.11 Fiber Optic Testing	127
	8.12 LAN Cable Testing	127
<b>9.</b>	<b>Cable Accessories</b>	<b>129</b>
	9.1 Coaxial Connectors	131
	9.2 Data Connectors	133
	9.3 Power Connectors	134
	9.4 Fiber Optic Connectors	137
	9.5 Cable Tray Systems	143
	9.6 NEMA Plug and Receptacle Configurations	145
<b>10.</b>	<b>Packaging of Wire and Cable</b>	<b>149</b>
	10.1 Reel Size	150
	10.2 Reel Handling	157
<b>11.</b>	<b>Industry Standards</b>	<b>159</b>
	11.1 Industry Standards List	161
	11.2 Fire Safety Tests	176
	11.3 Regulatory and Approval Agencies	182

<b>12.</b>	<b>Continental Europe</b>	<b>187</b>
12.1	European Union (EU) Standards	189
12.2	Austrian Standards	197
12.3	Belgian Standards	198
12.4	Danish Standards	199
12.9	Dutch Standards	199
12.5	French Standards	200
12.6	German Standards	202
12.7	Irish Standards	204
12.8	Italian Standards	205
12.10	Norwegian Standards	206
12.11	Portuguese Standards	207
12.12	Spanish Standards	208
12.13	Swedish Standards	209
12.14	Swiss Standards	210
<b>13.</b>	<b>United Kingdom</b>	<b>213</b>
13.1	Standards	214
13.2	Supply Voltage and Plug Configurations	219
<b>14.</b>	<b>Latin and South America</b>	<b>221</b>
14.1	Mexican Standards	222
14.2	Venezuelan Standards	223
14.3	Brazilian Standards	224
14.4	Colombian Standards	224
14.5	Argentine Standards	224
<b>15.</b>	<b>Canada</b>	<b>225</b>
15.1	Standards	226
15.2	Cable Types	228
15.3	Supply Voltage and Plug Configurations	231
15.4	Fire Ratings	232
15.5	Single Conductor Teck 90 Terminations	233

<b>16.</b>	<b>Asia Pacific</b>	<b>235</b>
	16.1 Australian Standards	236
	16.2 Singapore Standards	238
	16.3 Japanese Standards	239
	16.4 Chinese Standards	240
<b>17.</b>	<b>Conversion Tables</b>	<b>241</b>
	17.1 Metric to English Conductor Size	242
	17.2 Circular Measurements – Diameter, Circumference and Area	244
	17.3 Length, Weight, Area, Power and Energy	246
	17.4 Temperature Conversion	248
	17.5 kVA to Amperes	249
	17.6 Horsepower to Amperes	250
<b>18.</b>	<b>Formulas and Constants</b>	<b>251</b>
	18.1 Electrical Properties of Circuits	252
	18.2 Resistance and Weight of Conductors	252
	18.3 Resistance, Inductance and Capacitance in AC Circuits	253
	18.4 Series and Parallel Connections	253
	18.5 Engineering Notation	254
	18.6 Diameter of Multiconductor Cables	255
	18.7 Determination of Largest Possible Conductor in Cable Interstices	255
	18.8 Conductor Diameter from Wire Diameter	256
	18.9 Coaxial Capacitance	256
	18.10 Inductive Reactance	257
	<b>Glossary</b>	<b>259</b>
	<b>Index</b>	<b>293</b>



# 1. BASIC PRINCIPLES OF ELECTRICITY

1.1	Electricity	2
1.2	The Volt	2
1.3	The Ampere	2
1.4	The Ohm	2
1.5	Ohm's Law	2
1.6	Ampacity	2
1.7	Electrical Systems	3

### 1.1 ELECTRICITY

---

Electricity, simply put, is the flow of electric current along a conductor. This electric current takes the form of free electrons that transfer from one atom to the next. Thus, the more free electrons a material has, the better it conducts. There are three primary electrical parameters: the volt, the ampere and the ohm.

### 1.2 THE VOLT

---

The pressure that is put on free electrons that causes them to flow is known as electromotive force (EMF). The volt is the unit of pressure, i.e., the volt is the amount of electromotive force required to push a current of one ampere through a conductor with a resistance of one ohm.

### 1.3 THE AMPERE

---

The ampere defines the flow rate of electric current. For instance, when one coulomb (or  $6 \times 10^{18}$  electrons) flows past a given point on a conductor in one second, it is defined as a current of one ampere.

### 1.4 THE OHM

---

The ohm is the unit of resistance in a conductor. Three things determine the amount of resistance in a conductor: its size, its material, e.g., copper or aluminum, and its temperature. A conductor's resistance increases as its length increases or diameter decreases. The more conductive the materials used, the lower the conductor resistance becomes. Conversely, a rise in temperature will generally increase resistance in a conductor.

### 1.5 OHM'S LAW

---

Ohm's Law defines the correlation between electric current (I), voltage (V), and resistance (R) in a conductor. Ohm's Law can be expressed as:

$$V = I \times R$$

Where: V = volts  
I = amps  
R = ohms

### 1.6 AMPACITY

---

Ampacity is the amount of current a conductor can handle before its temperature exceeds accepted limits. These limits are given in the National Electrical Code (NEC), the Canadian Electrical Code and in other engineering documents such as those published by the Insulated Cable Engineers Association (ICEA). It is important to know that many external factors affect the ampacity of an electrical conductor and these factors should be taken into consideration before selecting the conductor size.

## 1.7 ELECTRICAL SYSTEMS

### 1.7.1 Medium Voltage

The most widely used medium voltage (2.4 to 35 kV) alternating current (AC) electrical distribution systems in North America are illustrated below:

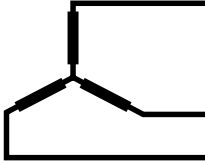

Figure 1.1 – Three phase wye (star), three wire

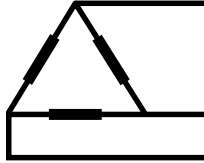

Figure 1.2 – Three phase delta, three wire

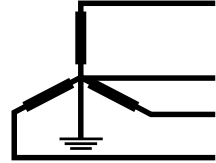

Figure 1.3 – Three phase star, four wire, grounded neutral

### 1.7.2 Low Voltage

Typical low-voltage systems (0 to 2,000 V) are illustrated below:

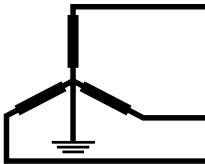

Figure 1.4 – Three phase wye (star), three wire, grounded neutral

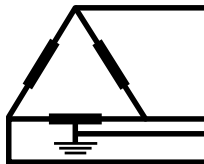

Figure 1.5 – Three phase delta, four wire, grounded neutral





# 2. CONDUCTORS

<b>2.1</b>	<b>Strand Types</b>	<b>7</b>
	2.1.1 Concentric Strand	7
	2.1.2 Bunch Strand	7
	2.1.3 Rope Strand	7
	2.1.4 Sector Conductor	7
	2.1.5 Segmental Conductor	7
	2.1.6 Annular Conductor	8
	2.1.7 Compact Strand	8
	2.1.8 Compressed Strand	8
<b>2.2</b>	<b>Coatings</b>	<b>10</b>
<b>2.3</b>	<b>Tensile Strength of Copper Wire</b>	<b>10</b>
<b>2.4</b>	<b>Copper Strand Properties</b>	<b>11</b>
	2.4.1 Strand Classes	11
	2.4.2 Solid Copper	12
	2.4.3 Class B, C and D Copper Strand	14
	2.4.4 Class H Copper	17
	2.4.5 Class I Copper	19
	2.4.6 Class K Copper	20
	2.4.7 Class M Copper	21
<b>2.5</b>	<b>Aluminum Strand Properties</b>	<b>22</b>
	2.5.1 Solid Aluminum	22
	2.5.2 Class B Aluminum	23
	2.5.3 ACSR	24
<b>2.6</b>	<b>Additional Conductor Properties</b>	<b>26</b>
	2.6.1 Stranding, Diameter, Area and DC Resistance (32 through 4/0 AWG)	26
	2.6.2 Stranding, Diameter, Area, DC Resistance and Weight (20 AWG through 2,000 kcmil)	28
	2.6.3 IEC Stranding	31

## CONDUCTORS

The conductor is the metallic component of cables through which electrical power or electrical signals are transmitted. Conductor size is usually specified by American Wire Gauge (AWG), circular mil area or in square millimeters.

### AWG

The American Wire Gauge (sometimes called Brown and Sharpe or B. and S.) is used almost exclusively in the USA for copper and aluminum wire. The Birmingham Wire Gauge (BWG) is used for steel armor wire.

The diameters according to the AWG are defined as follows: The diameter of size 4/0 (sometimes written 0000) equals 0.4600 inch and that of size #36 equals 0.0050 inch; the intermediate sizes are found by geometric progression. That is, the ratio of the diameter of one size to that of the next smaller size (larger gauge number) is:

$$\sqrt[39]{\frac{0.4600}{0.0050}} = 1.122932$$

### Circular Mil

Sizes larger than 4/0 are specified in terms of the total area of a cross-section of the copper in circular mils (cmil). A circular mil is a unit of area equal to the area of a circle one mil in diameter. It is  $\pi/4$  (equal to 0.7854) of a square mil (one mil = 0.001 inch). The area of a circle in circular mils is therefore equal to the square of its diameter in mils. A solid wire one inch in diameter has an area of 1,000,000 cmils, whereas one square inch equals  $4/\pi \times 1,000,000$  cmils (equal to 1,273,200 cmils).

### Square Millimeters

Metric sizes are given in terms of square millimeters (mm<sup>2</sup>).

### Conductor Characteristics

Relative electrical and thermal conductivities of common metal conductors are as follows:

**Table 2.1—Relative Electrical and Thermal Conductivities of Common Conductor Materials**

Metal	Relative Electrical Conductivity at 20°C	Relative Thermal Conductivity at 20°C
Silver	106	108
Copper (annealed)	100	100
Copper (hard drawn)	97	—
Gold	72	76
Aluminum	62	56
Magnesium	39	41
Zinc	29	29
Nickel	25	15
Cadmium	23	24
Cobalt	18	17
Iron	17	17
Platinum	16	18
Tin	15	17
Steel	12	13-17
Lead	8	9

Additional electrical properties can be found in Section 7 of this handbook.

## 2.1 STRAND TYPES

### 2.1.1 Concentric Strand

A concentric stranded conductor consists of a central wire or core surrounded by one or more layers of helically laid wires. Each layer after the first has six more wires than the preceding layer. Except in compact stranding, each layer is usually applied in a direction opposite to that of the layer under it.

If the core is a single wire and if it and all of the outer strands have the same diameter, the first layer will contain six wires; the second, twelve; the third, eighteen; etc.

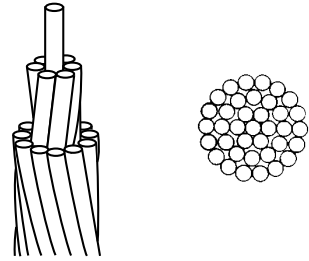

Figure 2.1—Concentric Strand

### 2.1.2 Bunch Strand

The term bunch stranding is applied to a collection of strands twisted together in the same direction without regard to the geometric arrangement.

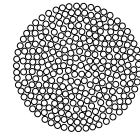

Figure 2.2—Bunch Strand

### 2.1.3 Rope Strand

A rope stranded conductor is a concentric stranded conductor each of whose component strands is itself stranded. A rope stranded conductor is described by giving the number of groups laid together to form the rope and the number of wires in each group.

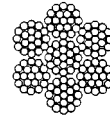

Figure 2.3—Rope Strand

### 2.1.4 Sector Conductor

A sector conductor is a stranded conductor whose cross-section is approximately the shape of a sector of a circle. A multiple conductor insulated cable with sector conductors has a smaller diameter than the corresponding cable with round conductors.

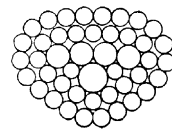

Figure 2.4—Sector Conductor

### 2.1.5 Segmental Conductor

A segmental conductor is a round, stranded conductor composed of three or four sectors slightly insulated from one another. This construction has the advantage of lower AC resistance due to increased surface area and skin effect.

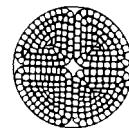

Figure 2.5—Segmental Conductor

## 2. Conductors

---

### 2.1.6 Annular Conductor

An annular conductor is a round, stranded conductor whose strands are laid around a suitable core. The core is usually made wholly or mostly of nonconducting material. This construction has the advantage of lower total AC resistance for a given cross-sectional area of conducting material due to the skin effect.

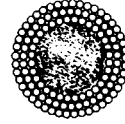

Figure 2.6—Annular Conductor

---

### 2.1.7 Compact Strand

A compact stranded conductor is a round or sector conductor having all layers stranded in the same direction and rolled to a predetermined ideal shape. The finished conductor is smooth on the surface and contains practically no interstices or air spaces. This results in a smaller diameter.

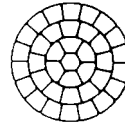

Figure 2.7—Compact Conductor

---

### 2.1.8 Compressed Strand

Compressed conductors are intermediate in size between standard concentric conductors and compact conductors. A comparison is shown below:

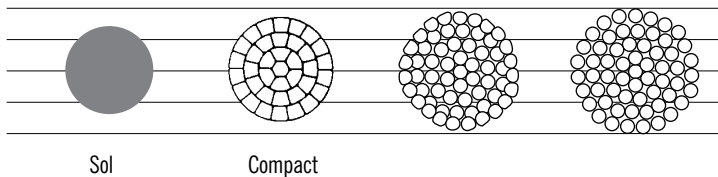

Figure 2.8—Comparative Sizes and Shapes of 1,000 kcmil Conductors

---

In a concentric stranded conductor, each individual wire is round and considerable space exists between wires. In a compressed conductor, the conductor has been put through a die that “squeezes out” some of the space between wires. In a compact conductor each wire is preformed into a trapezoidal shape before the wires are stranded together into a finished conductor. This results in even less space between wires. A compact conductor is, therefore, the smallest in diameter (except for a solid conductor, of course). Diameters for common conductor sizes are given in [Table 2.2](#).

Table 2.2—Diameters for Copper and Aluminum Conductors

Conductor Size		Nominal Diameters (in.)			
(AWG)	(kcmil)	Solid	Class B Compact	Class B Compressed	Class B Concentric
8	16.51	0.1285	0.134	0.141	0.146
6	26.24	0.1620	0.169	0.178	0.184
4	41.74	0.2043	0.213	0.225	0.232
3	52.62	0.2294	0.238	0.252	0.260
2	66.36	0.2576	0.268	0.283	0.292
1	83.69	0.2893	0.299	0.322	0.332
1/0	105.6	0.3249	0.336	0.361	0.373
2/0	133.1	0.3648	0.376	0.406	0.419
3/0	167.8	0.4096	0.423	0.456	0.470
4/0	211.6	0.4600	0.475	0.512	0.528
—	250	0.5000	0.520	0.558	0.575
—	300	0.5477	0.570	0.611	0.630
—	350	0.5916	0.616	0.661	0.681
—	400	0.6325	0.659	0.706	0.728
—	450	0.6708	0.700	0.749	0.772
—	500	0.7071	0.736	0.789	0.813
—	550	0.7416	0.775	0.829	0.855
—	600	0.7746	0.813	0.866	0.893
—	650	0.8062	0.845	0.901	0.929
—	700	0.8367	0.877	0.935	0.964
—	750	0.8660	0.908	0.968	0.998
—	800	0.8944	0.938	1.000	1.031
—	900	0.9487	0.999	1.061	1.093
—	1,000	1.0000	1.060	1.117	1.152

Sources: ASTM B8 and B496  
ICEA S-95-658 (NEMA WC-70)

## 2.2 COATINGS

There are three materials commonly used for coating a copper conductor: tin, silver and nickel.

Tin is the most common and is used for improved corrosion resistance, solderability and to reduce friction between strands in flexible cables.

Silver-plated conductors are used in high-temperature environments (150°C–200°C). It is also used for high-frequency applications where silver’s high conductivity (better than copper) and the “skin effect” work together to reduce attenuation at high frequencies.

Nickel coatings are used for conductors that operate between 200°C and 450°C. At these high temperatures, copper oxidizes rapidly if not nickel plated. One drawback of nickel is its poor solderability and higher electrical resistance.

## 2.3 TENSILE STRENGTH OF COPPER WIRE

Table 2.3–Tensile Strength of Copper Wire

Size (AWG)	Soft or Annealed Max. Breaking Load (lb.)	Medium Hard Drawn Min. Breaking Load (lb.)	Hard Drawn Min. Breaking Load (lb.)
4/0	6,000	6,970	8,140
3/0	4,750	5,660	6,720
2/0	3,765	4,600	5,530
1/0	2,985	3,730	4,520
1	2,435	3,020	3,690
2	1,930	2,450	3,010
3	1,535	1,990	2,440
4	1,215	1,580	1,970
6	765	1,010	1,280
8	480	645	825
10	315	410	530
12	200	262	335
14	125	167	215
16	78.5	106	135
18	49.5	67.6	85.5
20	31.0	43.2	54.2
22	19.4	27.3	34.1
24	12.7	17.5	21.7
26	7.94	11.1	13.7
28	4.99	7.02	8.64
30	3.14	4.48	5.47
32	2.01	2.90	3.53
34	1.25	1.82	2.20
36	0.79	1.16	1.40

## 2.4 COPPER STRAND PROPERTIES

### 2.4.1 Strand Classes

Table 2.4—Strand Classes

ASTM Standard	Construction	Class	Application
B8	Concentric lay	AA	For bare conductors – usually used in overhead lines.
		A	For bare conductors where greater flexibility than is afforded by Class AA is required.
		B	For conductors insulated with various materials such as EP, XLP, PVC, etc. This is the most common class.
		C	For conductors where greater flexibility is required than is provided by Class B.
		D	N/A
B173	Rope lay with concentric stranded members	G	Conductor constructions having a range of areas from 5,000,000 circular mils and employing 61 stranded members of 19 wires each down to No. 14 AWG containing seven stranded members of seven wires each. Typical uses are for portable (flexible) conductors and similar applications.
		H	Conductor constructions having a range of areas from 5,000,000 circular mils and employing 91 stranded members of 19 wires each down to No. 9 AWG containing 19 stranded members of seven wires each. Typical uses are for rubber-jacketed cords and conductors where flexibility is required, such as for use on take-up reels, over sheaves and apparatus conductors.

ASTM Standard	Construction	Class	Conductor Size	Individual Wire Size	Application	
			(kcmil/AWG)	Diameter (in.)	(AWG)	
B172	Rope lay with bunch stranded members	I	Up to 2,000	0.0201	24	Typical use is for special apparatus cable.
		K	Up to 2,000	0.0100	30	Typical use is for portable cord.
		M	Up to 1,000	0.0063	34	Typical use is for welding cable.
B174	Bunch stranded	I	7, 8, 9, 10	0.0201	24	Rubber-covered conductors.
		J	10, 12, 14, 16, 18, 20	0.0126	28	Fixture wire.
		K	10, 12, 14, 16, 18, 20	0.0100	30	Fixture wire, flexible cord and portable cord.
		L	10, 12, 14, 16, 18, 20	0.0080	32	Fixture wire and portable cord with greater flexibility than Class K.
		M	14, 16, 18, 20	0.0063	34	Heater cord and light portable cord.
		O	16, 18, 20	0.0050	36	Heater cord with greater flexibility than Class M.
		P	16, 18, 20	0.0040	38	More flexible conductors than provided in preceding classes.
Q	18, 20	0.0031	40	Oscillating fan cord. Very good flexibility.		

Source: Compiled from ASTM standards listed

## 2. Conductors

### 2.4.2 Solid Copper

Table 2.5—Standard Nominal Diameters and Cross-Sectional Areas of Solid Copper Wire

Size (AWG)	Diameter (mils)	Cross-Sectional Area (kcmils)	Weight (lb./1,000 ft.)	Breaking Strength Soft or Annealed (lb.)
4/0	460.0	211.600	—	—
3/0	409.6	167.800	—	—
2/0	364.8	133.100	—	—
1/0	324.9	105.600	—	—
1	289.3	83.690	—	—
2	257.6	66.360	—	—
3	229.4	52.620	—	—
4	204.3	41.740	—	—
5	181.9	33.090	—	—
6	162.0	26.240	—	—
7	144.3	20.820	—	—
8	128.5	16.510	—	—
9	114.4	13.090	—	—
10	101.9	10.380	31.43	314.0
11	90.7	8.230	24.92	249.0
12	80.8	6.530	19.77	197.5
13	72.0	5.180	15.68	156.6
14	64.1	4.110	12.43	142.2
15	57.1	3.260	9.86	98.5
16	50.8	2.580	7.82	78.1
17	45.3	2.050	6.20	61.9
18	40.3	1.620	4.92	49.2
19	35.9	1.290	3.90	39.0
20	32.0	1.020	3.09	30.9
21	28.5	0.812	2.452	24.5
22	25.3	0.640	1.945	19.4
23	22.6	0.511	1.542	15.4
24	20.1	0.404	1.223	12.7
25	17.9	0.320	0.970	10.1
26	15.9	0.253	0.770	7.98
27	14.2	0.202	0.610	6.33
28	12.6	0.159	0.484	5.02
29	11.3	0.128	0.384	3.98

Continued on next page >>



Table 2.5—Standard Nominal Diameters and Cross-Sectional Areas of Solid Copper Wire (Continued)

Size (AWG)	Diameter (mils)	Cross-Sectional Area (kcmils)	Weight (lb./1,000 ft.)	Breaking Strength Soft or Annealed (lb.)
30	10.0	0.100	0.303	3.16
31	8.9	0.0792	0.241	2.50
32	8.0	0.0640	0.191	1.99
33	7.1	0.0504	0.152	1.58
34	6.3	0.0397	0.120	1.25
35	5.6	0.0314	0.095	0.990
36	5.0	0.0250	0.076	0.785
37	4.5	0.0202	0.060	0.623
38	4.0	0.0160	0.048	0.494
39	3.5	0.0122	—	—
40	3.1	0.00961	—	—
41	2.8	0.00784	—	—
42	2.5	0.00625	—	—
43	2.2	0.00484	—	—
44	2.0	0.00400	—	—
45	1.76	0.00310	—	—
46	1.57	0.00246	—	—

Source: ASTM B258, Specification for Standard Nominal Diameters and Cross-Sectional Areas of AWG Sizes of Solid Round Wires Used as Electrical Conductors

## 2. Conductors

### 2.4.3 Class B, C and D Copper Strand

Table 2.6—Class B Concentric-Lay-Stranded Copper Conductors

Size (AWG or kcmil)	Number of Wires	Diameter of Each Strand (mils)	Weight (lb./1,000 ft.)	Nominal Overall Diameter (in.)
5,000	217	151.8	15,890	2.58
4,500	217	144	14,300	2.45
4,000	217	135.8	12,590	2.31
3,500	169	143.9	11,020	2.16
3,000	169	133.2	9,353	2.00
2,500	127	140.3	7,794	1.82
2,000	127	125.5	6,175	1.63
1,900	127	122.3	5,866	1.59
1,800	127	119.1	5,558	1.55
1,750	127	117.4	5,402	1.53
1,700	127	115.7	5,249	1.50
1,600	127	112.2	4,940	1.46
1,500	91	128.4	4,631	1.41
1,400	91	124.0	4,323	1.36
1,300	91	119.5	4,014	1.32
1,250	91	117.2	3,859	1.30
1,200	91	114.8	3,705	1.26
1,100	91	109.9	3,396	1.21
1,000	61	128.0	3,088	1.15
900	61	121.5	2,779	1.09
800	61	114.5	2,470	1.03
750	61	110.9	2,316	1.00
700	61	107.1	2,161	0.964
650	61	103.2	2,007	0.929
600	61	99.2	1,853	0.893
550	61	95.0	1,698	0.855
500	37	116.2	1,544	0.813
450	37	110.3	1,389	0.772
400	37	104.0	1,235	0.728
350	37	97.3	1,081	0.681
300	37	90.0	926.3	0.630
250	37	82.2	711.9	0.575
4/0	19	105.5	653.3	0.528

Continued >>

Table 2.6—Class B Concentric-Lay-Stranded Copper Conductors (Continued)

Size (AWG or kcmil)	Number of Wires	Diameter of Each Strand (mils)	Weight (lb./1,000 ft.)	Nominal Overall Diameter (in.)
3/0	19	94.0	518.1	0.470
2/0	19	83.7	410.9	0.419
1/0	19	74.5	325.8	0.373
1	19	66.4	258.4	0.332
2	7	97.4	204.9	0.292
3	7	86.7	162.5	0.260
4	7	77.2	128.9	0.232
5	7	68.8	102.2	0.206
6	7	61.2	81.05	0.184
7	7	54.5	64.28	0.164
8	7	48.6	50.97	0.146
9	7	43.2	40.42	0.130
10	7	38.5	32.06	0.116
12	7	30.5	20.16	0.0915
14	7	24.2	12.68	0.0726
16	7	19.2	7.974	0.0576
18	7	15.2	5.015	0.0456
20	7	12.1	3.154	0.0363

Source: ASTM B8 Specification for Concentric-Lay-Stranded Copper Conductors, Hard, Medium-Hard, or Soft

## 2. Conductors

**Table 2.7—Copper Strand Diameters**

Conductor Size		Stranding				
(AWG)	(kcmil)	Class B Compact (in.)	Class B Compressed (in.)	Class B Concentric (in.)	Class C Concentric (in.)	Class D Concentric (in.)
14	4.11	—	0.0704	0.0727	0.0735	0.0735
13	5.18	—	0.0792	0.0816	0.0825	0.0826
12	6.53	—	0.0888	0.0915	0.0925	0.0931
11	8.23	—	0.0998	0.103	0.104	0.104
10	10.39	—	0.113	0.116	0.117	0.117
9	13.09	—	0.126	0.130	0.131	0.132
8	16.51	0.134	0.141	0.146	0.148	0.148
7	20.82	—	0.158	0.164	0.166	0.166
6	26.24	0.169	0.178	0.184	0.186	0.186
5	33.09	—	0.200	0.206	0.208	0.209
4	41.74	0.213	0.225	0.232	0.234	0.235
3	52.62	0.238	0.252	0.260	0.263	0.264
2	66.36	0.268	0.283	0.292	0.296	0.297
1	83.69	0.299	0.322	0.332	0.333	0.333
1/0	105.6	0.336	0.362	0.372	0.374	0.374
2/0	133.1	0.376	0.406	0.418	0.420	0.420
3/0	167.8	0.423	0.456	0.470	0.471	0.472
4/0	211.6	0.475	0.512	0.528	0.529	0.530
—	250	0.520	0.558	0.575	0.576	0.576
—	300	0.570	0.611	0.630	0.631	0.631
—	350	0.616	0.661	0.681	0.681	0.682
—	400	0.659	0.706	0.728	0.729	0.729
—	450	0.700	0.749	0.772	0.773	0.773
—	500	0.736	0.789	0.813	0.814	0.815
—	550	0.775	0.829	0.855	0.855	0.855
—	600	0.813	0.866	0.893	0.893	0.893
—	650	0.845	0.901	0.929	0.930	0.930
—	700	0.877	0.935	0.964	0.965	0.965
—	750	0.908	0.968	0.999	0.999	0.998
—	800	0.938	1.000	1.030	1.032	1.032
—	900	0.999	1.061	1.094	1.093	1.095
—	1,000	1.060	1.117	1.152	1.153	1.153
—	1,100	—	1.173	1.209	1.210	1.211

Continued >>

Table 2.7—Copper Strand Diameters (Continued)

Conductor Size		Stranding				
(AWG)	(kcmil)	Class B Compact (in.)	Class B Compressed (in.)	Class B Concentric (in.)	Class C Concentric (in.)	Class D Concentric (in.)
—	1,200	—	1.225	1.263	1.264	1.264
—	1,250	—	1.251	1.289	1.290	1.290
—	1,300	—	1.275	1.314	1.316	1.316
—	1,400	—	1.323	1.365	1.365	1.365
—	1,500	—	1.370	1.412	1.413	1.413
—	1,600	—	1.415	1.459	1.460	1.460
—	1,700	—	1.459	1.504	1.504	1.504
—	1,750	—	1.480	1.526	1.527	1.527
—	1,800	—	1.502	1.548	1.548	1.549
—	1,900	—	1.542	1.590	1.590	1.591
—	2,000	—	1.583	1.632	1.632	1.632
—	2,500	—	1.769	1.824	1.824	1.824
—	3,000	—	1.938	1.998	1.998	1.998

## 2.4.4 Class H Copper

Table 2.8—Class H Rope-Lay-Stranded Copper Conductors

Size (AWG or kcmil)	Number of Strands	Construction	Nominal Diameter of Each Strand (in.)	Nominal O.D. (in.)	Nominal Weight (lb./1,000 ft.)
8	133	19x7	0.0111	0.167	52
7	133	19x7	0.0125	0.188	65
6	133	19x7	0.0140	0.210	82
5	133	19x7	0.0158	0.237	105
4	133	19x7	0.0177	0.266	132
3	133	19x7	0.0199	0.299	167
2	133	19x7	0.0223	0.335	208
2	259	37x7	0.0160	0.336	210
1	259	37x7	0.0180	0.378	266
1/0	259	37x7	0.0202	0.424	334
2/0	259	37x7	0.0227	0.477	422
3/0	259	37x7	0.0255	0.536	533
3/0	427	61x7	0.0198	0.535	532
4/0	259	37x7	0.0286	0.601	670
4/0	427	61x7	0.0223	0.602	675

Continued &gt;&gt;

## 2. Conductors

**Table 2.8—Class H Rope-Lay-Stranded Copper Conductors (Continued)**

Size (AWG or kcmil)	Number of Strands	Construction	Nominal Diameter of Each Strand (in.)	Nominal O.D. (in.)	Nominal Weight (lb./1,000 ft.)
250	427	61x7	0.0242	0.653	795
300	427	61x7	0.0265	0.716	953
350	427	61x7	0.0286	0.772	1,110
400	427	61x7	0.0306	0.826	1,270
450	427	61x7	0.0325	0.878	1,435
500	427	61x7	0.0342	0.923	1,590
550	703	37x19	0.0280	0.980	1,770
600	703	37x19	0.0292	1.022	1,920
650	703	37x19	0.0304	1.064	2,085
700	703	37x19	0.0316	1.106	2,255
750	703	37x19	0.0327	1.145	2,410
800	703	37x19	0.0337	1.180	2,560
900	703	37x19	0.0358	1.253	2,895
1,000	703	37x19	0.0377	1.320	3,205
1,100	703	37x19	0.0396	1.386	3,535
1,200	703	37x19	0.0413	1.446	3,845
1,250	703	37x19	0.0422	1.477	4,015
1,300	703	37x19	0.0430	1.505	4,170
1,400	703	37x19	0.0446	1.561	4,485
1,500	703	37x19	0.0462	1.617	4,815
1,600	1,159	61x19	0.0372	1.674	5,145
1,700	1,159	61x19	0.0383	1.724	5,455
1,750	1,159	61x19	0.0389	1.751	5,625
1,800	1,159	61x19	0.0394	1.773	5,770
1,900	1,159	61x19	0.0405	1.823	6,100
2,000	1,159	61x19	0.0415	1.868	6,400

Source: ICEA S-95-658 (NEMA 70) Appendix K

## 2.4.5 Class I Copper

Table 2.9—Class I (24 AWG Strands) Rope-Lay-Stranded Copper Conductors

Size (AWG or kcmil)	Construction	Nominal Number of Strands	Nominal O.D. (in.)	Nominal Weight (lb./1,000 ft.)
10	1x26	26	0.125	32.5
9	1x33	33	0.138	41
8	1x41	41	0.156	51
7	1x52	52	0.185	65
6	7x9	63	0.207	80
5	7x12	84	0.235	105
4	7x15	105	0.263	134
3	7x19	133	0.291	169
2	7x23	161	0.319	205
1	7x30	210	0.367	267
1/0	19x14	266	0.441	342
2/0	19x18	342	0.500	439
3/0	19x22	418	0.549	537
4/0	19x28	532	0.613	683
250	7x7x13	637	0.682	825
300	7x7x15	735	0.737	955
350	7x7x18	882	0.800	1,145
400	7x7x20	980	0.831	1,270
450	7x7x23	1,127	0.894	1,460
500	7x7x25	1,225	0.941	1,590
550	7x7x28	1,372	0.980	1,780
600	7x7x30	1,470	1.027	1,905
650	19x7x12	1,596	1.152	2,090
700	19x7x13	1,729	1.194	2,260
750	19x7x14	1,862	1.235	2,435
800	19x7x15	1,995	1.290	2,610
900	19x7x17	2,261	1.372	2,965
1,000	19x7x19	2,527	1.427	3,305
1,100	19x7x21	2,793	1.495	3,655
1,200	19x7x22	2,926	1.537	3,830
1,250	19x7x23	3,059	1.564	4,000
1,300	19x7x24	3,192	1.605	4,175
1,400	19x7x26	3,458	1.674	4,560
1,500	19x7x28	3,724	1.715	4,875
1,600	19x7x30	3,990	1.797	5,220
1,700	19x7x32	4,256	1.852	5,570
1,750	19x7x33	4,389	1.880	5,745
1,800	19x7x34	4,522	1.921	5,920
1,900	19x7x36	4,788	1.976	6,265
2,000	19x7x37	4,921	2.003	6,440

Source: ICEA S-75-381 (NEMA WC 58) Appendix K

## 2. Conductors

### 2.4.6 Class K Copper

**Table 2.10—Class K (30 AWG Strands) Rope-Lay-Stranded Copper Conductors**

Size (AWG or kcmil)	Rope-Lay with Bunch Stranding		Bunch Stranding		Weight (lb./1,000 ft.)
	Nominal Number of Strands	Strand Construction	Nominal Number of Strands	Approx. O.D. (in.)	
1,000	10,101	37x7x39	10,101	1.419	3,270
900	9,065	37x7x35	9,065	1.323	2,935
800	7,980	19x7x60	7,980	1.305	2,585
750	7,581	19x7x57	7,581	1.276	2,455
700	6,916	19x7x52	6,916	1.207	2,240
650	6,517	19x7x49	6,517	1.166	2,110
600	5,985	19x7x45	5,985	1.125	1,940
550	5,453	19x7x41	5,453	1.056	1,765
500	5,054	19x7x38	5,054	0.988	1,635
450	4,522	19x7x34	4,522	0.933	1,465
400	3,990	1x7x30	3,990	0.878	1,290
350	3,458	19x7x26	3,458	0.809	1,120
300	2,989	7x7x61	2,989	0.768	960
250	2,499	7x7x51	2,499	0.682	802
4/0	2,107	7x7x43	2,107	0.627	676
3/0	1,666	7x7x34	1,666	0.533	535
2/0	1,323	7x7x27	1,323	0.470	425
1/0	1,064	19x56	1,064	0.451	338
1	836	19x44	836	0.397	266
2	665	19x35	665	0.338	211
3	532	19x28	532	0.304	169
4	420	7x60	420	0.272	132
5	336	7x48	336	0.235	106
6	266	7x38	266	0.202	84
7	210	7x30	210	0.179	66
8	168	7x24	168	0.157	53
9	133	7x19	133	0.146	42
10	—	—	104	0.126	32.5
12	—	—	65	0.101	20.3
14	—	—	41	0.078	12.8
16	—	—	26	0.060	8.0
18	—	—	16	0.048	5.0
20	—	—	10	0.038	3.2

Sources: ASTM B172 Specification for Rope-Lay-Stranded Copper Conductors Having Bunch-Stranded Members and ICEA S-75-381 (NEMA WC58)  
Appendix K



## 2.4.7 Class M Copper

Table 2.11—Class M (34 AWG Strands) Rope-Lay-Stranded Copper Conductors

Size (AWG or kcmil)	Rope-Lay with Bunch Stranding		Bunch Stranding		Weight (lb./1,000 ft.)
	Nominal Number of Strands	Strand Construction	Nominal Number of Strands	Approx. O.D. (in.)	
1,000	25,193	61x7x59	25,193	1.404	3,240
900	22,631	61x7x53	22,631	1.331	2,910
800	20,069	61x7x47	20,069	1.256	2,580
750	18,788	61x7x44	18,788	1.207	2,415
700	17,507	61x7x41	17,507	1.183	2,250
650	16,226	61x7x38	16,226	1.133	2,085
600	14,945	61x7x35	14,945	1.084	1,920
550	13,664	61x7x32	13,664	1.035	1,755
500	12,691	37x7x49	12,691	0.997	1,630
450	11,396	37x7x44	11,396	0.940	1,465
400	10,101	37x7x39	10,101	0.901	1,300
350	8,806	37x7x34	8,806	0.825	1,130
300	7,581	19x7x57	7,581	0.768	975
250	6,384	19x7x48	6,384	0.713	821
4/0	5,320	19x7x40	5,320	0.645	684
3/0	4,256	19x7x32	4,256	0.576	547
2/0	3,325	19x7x25	3,325	0.508	427
1/0	2,646	7x7x54	2,646	0.423	337
1	2,107	7x7x43	2,107	0.376	268
2	1,666	7x7x34	1,666	0.337	212
3	1,323	7x7x27	1,323	0.305	169
4	1,064	19x56	1,064	0.269	134
5	836	19x44	836	0.240	105
6	665	19x35	665	0.215	84
7	532	19x28	532	0.196	67
8	420	7x60	420	0.162	53
9	336	7x48	336	0.146	42
10	259	7x37	259	0.126	32.5
12	168	7x24	168	0.101	21.0
14	—	—	104	0.078	12.8
16	—	—	65	0.060	8.0
18	—	—	41	0.048	5.0
20	—	—	26	0.038	3.2

Sources: ASTM B172 Specification for Rope-Lay-Stranded Copper Conductors Having Bunch-Stranded Members and ICEA S-75-381 (NEMA WC58)

## 2.5 ALUMINUM STRAND PROPERTIES

### 2.5.1 Solid Aluminum

Table 2.12—Aluminum 1350 Solid Round Wire

Size (AWG or kcmil)	Diameter (mils)	Cross-Sectional Area (kcmils)	Weight (lb./1,000 ft.)
4/0	460.0	211.600	194.40
3/0	409.6	167.800	154.20
2/0	364.8	133.100	122.30
1/0	324.9	105.600	97.00
1	289.3	83.690	76.91
2	257.6	66.360	60.98
3	229.4	52.620	48.36
4	204.3	41.740	38.35
5	181.9	33.090	30.40
6	162.0	26.240	24.12
7	144.3	20.820	19.13
8	128.5	16.510	15.17
9	114.4	13.090	12.03
10	101.9	10.380	9.542
11	90.7	8.230	7.559
12	80.8	6.530	5.999
13	72.0	5.180	4.764
14	64.1	4.110	3.776
15	57.1	3.260	2.996
16	50.8	2.580	2.371
17	45.3	2.050	1.886
18	40.3	1.620	1.492
19	35.9	1.290	1.184
20	32.0	1.020	0.9410
21	28.5	0.812	0.7464
22	25.3	0.640	0.5882
23	22.6	0.511	0.4693
24	20.1	0.404	0.3713
25	17.9	0.320	0.2944
26	15.9	0.253	0.2323
27	14.2	0.202	0.1853
28	12.6	0.159	0.1459
29	11.3	0.128	0.1173
30	10.0	0.100	0.09189

Source: ASTM B609 Specification for Aluminum 1350 Round Wire, Annealed and Intermediate Tempers

## 2.5.2 Class B Aluminum

Table 2.13—Class B Concentric-Lay-Stranded Compressed, Reverse-Lay Aluminum 1350 Conductors

Size (AWG or kcmil)	Number of Wires	Diameter of Each Wire (mils)	Nominal Overall Diameter (in.)
4,000	217	135.8	—
3,500	169	143.9	—
3,000	169	133.2	—
2,500	127	140.3	—
2,000	127	125.5	1.583
1,900	127	122.3	1.542
1,800	127	119.1	1.502
1,750	127	117.4	1.480
1,700	127	115.7	1.459
1,600	127	112.2	1.415
1,500	91	128.4	1.370
1,400	91	124.0	1.323
1,300	91	119.5	1.275
1,250	91	117.2	1.250
1,200	91	114.8	1.225
1,100	91	109.9	1.173
1,000	61	128.0	1.117
900	61	121.5	1.060
800	61	114.5	1.000
750	61	110.9	0.968
700	61	107.1	0.935
650	61	103.2	0.901
600	61	99.2	0.866
550	61	95.0	0.829
500	37	116.2	0.789
450	37	110.3	0.749
400	37	104.0	0.706
350	37	97.3	0.661
300	37	90.0	0.611
250	37	82.2	0.558
4/0	19	105.5	0.512
3/0	19	94.0	0.456
2/0	19	83.7	0.405

Continued &gt;&gt;

## 2. Conductors

**Table 2.13—Class B Concentric-Lay-Stranded Compressed, Reverse-Lay Aluminum 1350 Conductors (Continued)**

Size (AWG or kcmil)	Number of Wires	Diameter of Each Wire (mils)	Nominal Overall Diameter (in.)
1/0	19	74.5	0.362
1	19	66.4	0.322
2	7	97.4	0.283
3	7	86.7	0.252
4	7	77.2	0.225
5	7	68.8	0.200
6	7	61.2	0.178
7	7	54.5	0.159
8	7	48.6	0.142
9	7	43.2	0.126
10	7	38.5	0.113
12	7	30.5	0.089
14	7	24.2	0.071
16	7	19.2	—
18	7	15.2	—
20	7	12.1	—

Source: ASTM B231 Concentric-Lay-Stranded Aluminum 1350 Conductors

### 2.5.3 ACSR

**Table 2.14—Concentric-Lay-Stranded Aluminum Conductors, Coated-Steel Reinforced (ACSR)**

Size (AWG or kcmil)	Stranding		Weight (lb./1,000 ft.)
	Aluminum Number/Diameter (in.)	Steel Number/Diameter (in.)	
2,156	84/0.1602	19/0.0961	2,511
1,780	84/0.1456	19/0.0874	2,074
1,590	54/0.1716	19/0.1030	2,044
1,590	45/0.1880	7/0.1253	1,792
1,431	54/0.1628	19/0.0977	1,840
1,431	45/0.1783	7/0.1189	1,613
1,272	54/0.1535	19/0.0921	1,635
1,272	45/0.1681	7/0.1121	1,434
1,113	54/0.1436	19/0.0862	1,431
1,113	45/0.1573	7/0.1049	1,255
954.0	54/0.1329	7/0.1329	1,229
954.0	45/0.1456	7/0.0971	1,075

Continued >>

Table 2.14—Concentric-Lay-Stranded Aluminum Conductors, Coated-Steel Reinforced (ACSR) (Continued)

Size (AWG or kcmil)	Stranding		Weight (lb./1,000 ft.)
	Aluminum Number/Diameter (in.)	Steel Number/Diameter (in.)	
795.0	45/0.1329	7/0.0886	896
795.0	26/0.1749	7/0.1360	1,094
795.0	24/0.1820	7/0.1213	1,023
636.0	26/0.1564	7/0.1216	875
636.0	24/0.1628	7/0.1085	819
636.0	18/0.1880	1/0.1880	690
556.5	26/0.1463	7/0.1138	766
556.5	24/0.1523	7/0.1015	717
556.5	18/0.1758	1/0.1758	604
477.0	30/0.1261	7/0.1261	747
477.0	26/0.1354	7/0.1053	657
477.0	24/0.1410	7/0.0940	615
477.0	18/0.1628	1/0.1628	518
397.5	26/0.1236	7/0.0961	547
397.5	24/0.1287	7/0.0858	512
397.5	18/0.1486	1/0.1486	432
336.4	30/0.1059	7/0.1059	527
336.4	26/0.1137	7/0.0884	463
336.4	18/0.1367	1/0.1367	365
266.8	26/0.1013	7/0.0788	367
266.8	18/0.1217	1/0.1217	290
4/0	6/0.1878	1/0.1878	291.1
211.3	12/0.1327	7/0.1327	527.5
203.2	16/0.1127	19/0.0977	676.8
190.8	12/0.1261	7/0.1261	476.3
176.9	12/0.1214	7/0.1214	441.4
3/0	6/0.1672	1/0.1672	230.8
159.0	12/0.1151	7/0.1151	396.8
134.6	12/0.1059	7/0.1059	336.0
2/0	6/0.1489	1/0.1489	183.1
110.8	12/0.0961	7/0.0961	276.6
1/0	6/0.1327	1/0.1327	145.2
101.8	12/0.0921	7/0.0921	254.1
80.0	8/0.1000	1/0.1670	149.0
2	7/0.0974	1/0.1299	106.7
2	6/0.1052	1/0.1052	91.3
4	7/0.0772	1/0.1029	67.0
4	6/0.0834	1/0.0834	57.4
6	6/0.0661	1/0.0661	36.1

Source: ASTM B232 Specification for Concentric-Lay-Stranded Aluminum Conductors, Coated-Steel Reinforced (ACSR)

## 2.6 ADDITIONAL CONDUCTOR PROPERTIES

### 2.6.1 Stranding, Diameter, Area and DC Resistance (32 Through 4/0 AWG)

Table 2.15—Stranding, Diameter, Area and DC Resistance

Size (AWG)	Stranding (No./AWG)	Conductor Diameter		Conductor Area		Copper DC Resistance at 20°C	
		(in.)	(mm)	(cmils)	(mm <sup>2</sup> )	(ohms/1,000 ft.)	(ohms/km)
30	Solid	0.010	0.254	100.0	0.051	106.6	349.8
	7/38	0.012	0.305	112.0	0.057	96.2	315.6
28	Solid	0.013	0.320	159.0	0.081	70.8	232.3
	7/36	0.015	0.381	175.0	0.089	67.5	221.5
	19/40	0.016	0.406	182.6	0.093	58.9	193.3
26	Solid	0.016	0.406	253.0	0.128	44.5	146.0
	7/34	0.019	0.483	278.0	0.141	42.5	139.4
	19/38	0.021	0.533	304.0	0.154	38.9	127.6
24	Solid	0.020	0.511	404.0	0.205	27.2	89.2
	7/32	0.024	0.610	448.0	0.227	25.7	84.3
	10/34	0.023	0.584	397.0	0.201	28.8	94.5
	19/36	0.025	0.635	475.0	0.241	24.9	81.7
22	Solid	0.025	0.635	475.0	0.326	16.7	54.8
	7/30	0.031	0.787	700.0	0.355	16.6	54.5
	16/34	0.030	0.762	635.0	0.322	18.0	59.1
	19/34	0.032	0.813	754.0	0.382	15.5	50.9
20	Solid	0.032	0.813	1,020	0.517	10.5	34.5
	7/28	0.038	0.965	1,113	0.564	10.3	33.8
	10/30	0.036	0.914	1,000	0.507	11.4	37.4
	19/32	0.040	1.02	1,197	0.607	9.48	31.1
	26/34	0.037	0.940	1,032	0.523	11.3	37.1
18	Solid	0.040	1.02	1,620	0.821	6.77	22.2
	7/26	0.048	1.22	1,771	0.897	6.45	21.2
	16/30	0.046	1.17	1,600	0.811	6.15	23.5
	19/30	0.050	1.27	1,900	0.963	6.10	20.0
	41/34	0.047	1.19	1,627	0.824	7.08	23.2
16	Solid	0.051	1.29	2,580	1.31	4.47	14.7
	7/24	0.058	1.47	2,828	1.43	4.04	13.3
	19/29	0.057	1.45	2,426	1.23	4.82	15.8
	26/30	0.050	1.52	2,600	1.32	4.39	14.4
	65/34	0.060	1.52	2,580	1.32	4.47	14.7

Continued >>

Table 2.15—Stranding, Diameter, Area and DC Resistance (Continued)

Size (AWG)	Stranding (No./AWG)	Conductor Diameter		Conductor Area		Copper DC Resistance at 20°C	
		(in.)	(mm)	(cmils)	(mm <sup>2</sup> )	(ohms/1,000 ft.)	(ohms/km)
14	Solid	0.064	1.63	4,110	2.08	2.68	8.79
	19/27	0.071	1.80	3,838	1.94	3.05	10.0
	41/30	0.077	1.96	4,100	2.08	2.81	9.22
12	Solid	0.081	2.05	6,530	3.31	1.65	5.41
	19/25	0.090	2.29	6,080	3.08	1.87	6.14
	65/30	0.091	2.31	6,500	3.29	1.82	5.97
10	Solid	0.102	2.59	10,380	5.26	1.11	3.64
	37/36	0.112	2.84	9,361	4.74	1.38	4.53
	105/30	0.130	3.30	10,500	5.32	1.10	3.61
8	Solid	0.129	3.28	16,500	8.36	0.718	2.36
	133/29	0.166	4.22	17,024	8.63	0.710	2.33
	168/30	0.174	4.42	16,800	8.51	0.700	2.30
6	Solid	0.162	4.12	26,240	13.3	0.440	1.44
	133/27	0.210	5.33	26,866	13.6	0.430	1.41
	266/30	0.204	5.18	26,600	13.5	0.440	1.44
4	Solid	0.204	5.18	41,740	21.1	0.275	0.902
	133/25	0.257	6.53	42,560	21.6	0.290	0.951
	420/30	0.257	6.53	42,000	21.3	0.280	0.919
2	Solid	0.258	6.54	66,360	33.6	0.172	0.564
	665/30	0.338	8.59	66,500	33.7	0.180	0.591
1	Solid	0.289	7.34	83,690	42.4	0.142	0.466
	817/30	0.328	8.33	81,700	41.4	0.140	0.459
1/0	Solid	0.325	8.26	105,600	53.5	0.111	0.364
	1,045/30	0.410	10.4	104,500	53.0	0.120	0.394
2/0	Solid	0.365	9.27	133,100	67.4	0.088	0.289
	1,330/30	0.496	12.6	133,000	67.4	0.099	0.325
3/0	Solid	0.410	10.4	167,800	85.0	0.070	0.230
	1,661/30	0.464	11.8	166,100	84.2	0.068	0.223
4/0	Solid	0.460	11.7	211,600	107	0.055	0.180
	2,104/30	0.608	15.4	210,400	107	0.060	0.197

## 2. Conductors

### 2.6.2 Stranding, Diameter, Area, DC Resistance and Weight (20 AWG Through 2,000 kcmil)

Table 2.16—Copper Conductor Stranding, Diameter, Area, Weight and DC Resistance

Nominal Area		Size (AWG)	Number/Diameter of Individual Wires		Overall Diameter		Nominal Weight		DC Resistance at 20°C (68°F)	
(mm <sup>2</sup> )	(cmils)		(in.)	(mm)	(in.)	(mm)	(lb./1,000 ft.)	(kg/km)	(ohms/1,000 ft.)	(ohms/km)
0.50	987	—	1/0.032	1/0.613	0.032	0.81	3.100	4.613	10.13	32.33
—	1,020	20	7/0.0121	7/0.307	0.036	0.91	3.157	4.098	10.22	33.77
0.75	1,480	—	1/0.036	1/0.991	0.039	0.99	4.603	6.851	6.820	22.37
—	1,620	18	1/0.403	1/1.02	0.040	1.02	4.917	7.316	6.387	20.95
—	1,620	18	7/0.0152	7/0.386	0.046	1.16	4.980	7.410	6.523	21.40
1.0	1,970	—	1/0.045	1/1.14	0.045	1.14	6.130	9.122	5.127	16.80
1.0	1,970	—	7/0.017	7/0.432	0.051	1.30	6.293	9.266	5.213	17.11
—	2,580	16	1/0.0508	1/1.29	0.061	1.29	7.810	11.63	4.020	13.19
—	2,580	16	7/0.0192	7/0.488	0.058	1.46	7.877	11.82	4.087	13.41
1.5	2,960	—	1/0.055	1/1.40	0.055	1.40	9.157	13.63	3.430	11.25
1.5	2,960	—	7/0.021	7/0.533	0.063	1.60	8.837	14.14	3.417	11.21
—	4,110	14	1/0.641	1/1.63	0.064	1.63	12.44	18.51	2.524	8.281
—	4,110	14	7/0.0242	7/0.615	0.073	1.84	12.62	18.78	2.573	8.442
2.5	4,930	—	1/0.071	1/1.80	0.071	1.80	15.26	22.71	2.057	6.750
2.5	4,930	—	7/0.027	7/0.686	0.081	2.06	15.71	23.38	2.067	6.782
—	6,530	12	1/0.0808	1/2.05	0.081	2.05	19.76	29.41	1.589	5.212
—	6,530	12	7/0.0305	7/0.755	0.092	2.32	20.05	29.84	1.620	5.315
4	7,890	—	1/0.089	1/2.26	0.089	2.26	23.98	35.68	1.309	4.296
4	7,890	—	7/0.034	7/0.864	0.102	2.59	24.91	37.08	1.304	4.277
—	10,380	10	1/0.1019	1/2.59	0.102	2.59	31.43	46.77	0.999	3.277
—	10,380	10	7/0.0385	7/0.978	0.116	2.93	31.94	47.54	1.017	3.335
6	11,800	—	1/0.109	1/2.77	0.109	2.77	35.97	53.52	0.8730	2.864
6	11,800	—	7/0.042	7/0.107	0.126	3.21	38.00	56.55	0.8543	2.803
—	13,090	9	1/0.1144	7/2.91	0.1144	2.91	39.60	58.93	0.7923	2.600
—	13,090	9	7/0.0432	7/1.10	0.130	3.30	40.23	59.86	0.8073	2.649
—	16,510	8	1/0.1285	1/3.26	0.128	3.26	50.17	74.36	0.6147	2.061
—	16,510	8	7/0.0486	7/1.23	0.146	3.70	50.90	75.75	0.6380	2.093
10	19,700	—	1/0.141	1/3.58	0.141	3.58	60.17	89.54	0.5217	1.711
10	19,700	—	7/0.054	7/1.37	0.162	4.12	62.83	93.51	0.5167	1.695
—	20,820	7	1/0.1443	1/3.67	0.144	3.67	63.03	93.80	0.4980	1.634
—	20,820	7	7/0.0545	7/1.38	0.164	4.15	64.00	95.24	0.5073	1.664

Continued >>



Table 2.16—Copper Conductor Stranding, Diameter, Area, Weight and DC Resistance (Continued)

Nominal Area		Size	Number/Diameter of Individual Wires		Overall Diameter		Nominal Weight		DC Resistance at 20°C (68°F)	
(mm <sup>2</sup> )	(cmils)		(in.)	(mm)	(in.)	(mm)	(lb./1,000 ft.)	(kg/km)	(ohms/1,000 ft.)	(ohms/km)
—	26,240	6	1/0.162	1/4.11	0.162	4.11	79.43	118.2	0.3950	1.296
—	26,240	6	7/0.0612	7/1.55	0.184	4.66	80.73	120.1	0.4023	1.320
16	31,600	—	7/0.068	7/1.73	0.204	5.18	99.67	148.3	0.3259	1.069
—	33,090	6	7/0.0688	7/1.75	0.206	5.24	102.0	151.8	0.3183	1.044
—	41,740	4	7/0.0772	7/1.96	0.232	5.88	128.4	191.1	0.2528	0.8295
25	49,300	—	7/0.065	7/2.16	0.255	6.48	155.7	231.7	0.2176	0.6843
—	52,620	3	7/0.0867	7/2.20	0.260	6.61	162.0	241.1	0.2005	0.6577
35	69,100	—	7/0.100	7/2.54	0.300	7.62	215.5	320.7	0.1507	0.4944
35	69,100	—	19/0.061	19/1.55	0.305	7.75	218.1	324.5	0.1495	0.4909
—	83,690	1	19/0.0664	19/1.63	0.332	8.43	258.4	384.5	0.1261	0.4139
50	98,700	—	19/0.073	19/1.85	0.365	9.27	312.3	464.8	0.1044	0.3424
—	105,400	1/0	19/0.0745	19/1.89	0.373	9.46	325.3	484.1	0.10020	0.3288
—	133,100	2/0	19/0.0837	19/2.13	0.419	10.6	410.7	611.1	0.07940	0.2605
70	138,000	—	19/0.086	19/2.18	0.430	10.9	433.3	645.0	0.07520	0.2467
—	167,800	3/0	19/0.094	19/2.39	0.470	11.9	517.7	770.4	0.06293	0.2065
—	167,800	3/0	37/0.0673	37/1.71	0.471	12.0	517.0	769.4	0.06310	0.2070
95	187,000	—	19/0.101	19/2.57	0.505	12.8	597.7	889.4	0.05453	0.1789
—	211,600	4/0	19/0.1055	19/2.68	0.528	13.4	652.3	970.8	0.04997	0.1639
120	237,000	—	37/0.0811	37/2.06	0.567	14.4	749.0	1,115	0.04357	0.1429
—	250,000	—	37/0.0822	37/2.09	0.575	14.6	771.3	1,148	0.04230	0.1388
150	300,000	—	37/0.090	37/2.29	0.630	16.0	924.7	1,376	0.03527	0.1157
—	350,000	—	37/0.0973	37/2.47	0.681	17.3	1,081	1,609	0.03018	0.09903
185	365,000	—	37/0.100	37/2.54	0.700	17.8	1,142	1,699	0.02857	0.09375
—	400,000	—	37/0.104	37/2.64	0.728	18.5	1,235	1,838	0.02642	0.06668
240	474,000	—	37/0.114	37/2.90	0.798	20.3	1,484	2,206	0.02199	0.07214
240	474,000	—	61/0.089	61/2.26	0.801	20.3	1,491	2,219	0.02189	0.07181
—	500,000	—	37/0.1162	37/2.95	0.813	20.7	1,608	2,294	0.02116	0.06943
—	500,000	—	61/0.0905	61/2.30	0.814	20.7	1,549	2,295	0.02117	0.06944
300	592,000	—	61/0.099	61/2.51	0.891	22.6	1,842	2,746	0.02102	0.05803
—	600,000	—	61/0.0992	61/2.52	0.893	22.7	1,853	2,757	0.01762	0.05780
—	700,000	—	61/0.1071	61/2.72	0.964	24.5	2,160	3,214	0.01511	0.04959
—	750,000	—	61/0.1109	61/2.82	0.998	25.4	2,316	3,446	0.01410	0.04625

Continued &gt;&gt;

## 2. Conductors

**Table 2.16—Copper Conductor Stranding, Diameter, Area, Weight and DC Resistance (Continued)**

Nominal Area		Size	Number/Diameter of Individual Wires		Overall Diameter		Nominal Weight		DC Resistance at 20°C (68°F)	
(mm <sup>2</sup> )	(cmils)		(in.)	(mm)	(in.)	(mm)	(lb./1,000 ft.)	(kg/km)	(ohms/1,000 ft.)	(ohms/km)
—	750,000	—	91/0.0908	91/2.31	0.999	25.4	2,316	3,447	0.01410	0.04625
400	789,000	—	61/0.114	61/2.90	1.026	26.1	2,447	3,642	0.01334	0.04377
—	800,000	—	61/0.1145	61/2.91	1.031	26.2	2,468	3,673	0.01322	0.04338
—	800,000	—	91/0.0938	91/2.38	1.032	26.2	2,471	3,678	0.01321	0.04334
500	1,000,000	—	61/0.1280	61/3.25	1.152	29.3	3,085	4,590	0.01058	0.03472
—	1,000,000	—	91/0.1048	91/2.66	1.153	29.3	3,085	4,591	0.01058	0.03472
625	1,234,000	—	91/0.117	91/2.97	1.287	32.7	3,845	5,722	0.00849	0.02786
—	1,250,000	—	91/0.1172	91/2.98	1.289	32.7	3,858	5,742	0.008460	0.02776
—	1,250,000	—	127/0.0992	127/2.52	1.290	32.8	3,858	6,741	0.008463	0.02777
—	1,500,000	—	91/0.1284	91/3.26	1.412	35.9	4,631	6,892	0.007050	0.02313
—	1,500,000	—	127/0.1087	127/2.76	1.413	35.9	4,632	6,894	0.007183	0.02312
800	1,580,000	—	91/0.132	91/3.35	1.452	36.9	4,894	7,284	0.006670	0.02188
1,000	1,970,000	—	91/0.147	91/3.73	1.617	41.1	6,070	9,033	0.005380	0.01765
—	2,000,000	—	127/0.1255	127/3.19	1.632	41.5	6,175	9,189	0.005287	0.01735
—	2,000,000	—	169/0.1088	169/2.76	1.632	41.5	6,176	9,191	0.005287	0.01735

Based on British (BSA), Canadian (CSA), American (ASTM and ICEA) and German (VDE) Standards

## 2.6.3 IEC Stranding

Table 2.17—Typical IEC Stranding

Cross Section (mm <sup>2</sup> )	Ordinary Stranding (Class 2)	Multi-Wire Stranding	Fine Wire Stranding (Class 5)	Extra-Fine Wire Stranding (Class 6)			
	No./Dia. (mm)	No./Dia. (mm)	No./Dia. (mm)	No./Dia. (mm)			
0.05	—	—	—	—	—	—	25/0.05
0.08	—	—	—	—	—	—	41/0.05
0.14	—	—	—	18/0.10	18/0.1	36/0.07	72/0.05
0.25	—	—	14/0.16	32/0.10	32/0.1	65/0.07	128/0.05
0.34	—	7/0.25	19/0.16	42/0.10	42/0.1	88/0.07	174/0.05
0.38	—	7/0.27	12/0.21	21/0.16	48/0.1	100/0.07	194/0.05
0.5	7/0.30	7/0.30	16/0.21	28/0.16	64/0.1	131/0.07	256/0.05
0.75	7/0.37	7/0.37	24/0.21	42/0.16	69/0.1	195/0.07	384/0.05
1.0	7/0.43	7/0.43	32/0.21	56/0.16	128/0.1	260/0.07	512/0.05
1.5	7/0.52	7/0.52	30/0.26	84/0.16	192/0.1	392/0.07	768/0.05
2.5	7/0.67	19/0.41	50/0.26	140/0.16	320/0.1	651/0.07	1,280/0.05
4	7/0.85	19/0.52	56/0.31	224/0.16	512/0.1	1,040/0.07	—
6	7/1.05	19/0.64	84/0.31	192/0.21	768/0.1	1,560/0.07	—
10	7/1.35	49/0.51	80/0.41	320/0.21	1,280/0.1	2,600/0.07	—
16	7/1.70	49/0.65	128/0.41	512/0.21	2,048/0.1	—	—
25	7/2.13	84/0.62	200/0.41	800/0.21	3,200/0.1	—	—
35	7/2.52	133/0.58	280/0.41	1,120/0.21	—	—	—
50	19/1.83	133/0.69	400/0.41	705/0.31	—	—	—
70	19/2.17	189/0.69	356/0.51	990/0.31	—	—	—
95	19/2.52	259/0.69	485/0.51	1,340/0.31	—	—	—
120	37/2.03	336/0.67	614/0.51	1,690/0.31	—	—	—
150	37/2.27	392/0.69	765/0.51	2,123/0.31	—	—	—
185	37/2.52	494/0.69	944/0.51	1,470/0.41	—	—	—
240	61/2.24	627/0.70	1,225/0.51	1,905/0.41	—	—	—
300	61/2.50	790/0.70	1,530/0.51	2,385/0.41	—	—	—
400	61/2.89	—	2,035/0.51	—	—	—	—
500	61/3.23	—	1,768/0.61	—	—	—	—

Note: Additional information is available in IEC 60228.



# 3. INSULATION AND JACKET MATERIALS

<b>3.1</b>	<b>Purpose</b>	<b>34</b>
<b>3.2</b>	<b>Types and Applications</b>	<b>34</b>
	3.2.1 Thermoplastics	34
	3.2.2 Thermosets	36
	3.2.3 Fibrous Coverings	37
	3.2.4 Additional Information	37
<b>3.3</b>	<b>Color Coding</b>	<b>38</b>
	3.3.1 Power, Control, Instrumentation and Thermocouple	38
	3.3.2 Belden Electronic Color Code	43
	3.3.3 Telecommunication Color Codes	46
<b>3.4</b>	<b>Properties</b>	<b>47</b>
	3.4.1 Thermoplastic	47
	3.4.2 Thermoset	50
	3.4.3 EPR Versus XLPE	51
	3.4.4 Thermal Characteristics	51
	3.4.5 Halogen Content	52
	3.4.6 Limiting Oxygen Index (LOI)	52
	3.4.7 Dielectric Constant	53

### 3.1 PURPOSE

Conductors need to be electrically isolated from other conductors and from the environment to prevent short circuits and for safety. Insulation is applied around a conductor to provide this isolation. Most wire and cable insulations consist of polymers (plastics), which have a high resistance to the flow of electric current. A jacket is the outermost layer of a cable whose primary function is to protect the insulation and conductor core from external physical forces and chemical deterioration.

### 3.2 TYPES AND APPLICATIONS

---

#### 3.2.1 Thermoplastics

##### Chlorinated Polyethylene (CPE)

CPE is one of the few polymers available in both thermoplastic and thermoset (cross-linked) versions. As a rule, thermoset formulations have better high-temperature properties than thermoplastics but are also higher in cost. Thermoplastic CPE is more common than thermoset CPE. Properties of both thermoplastic and thermoset CPE are given in [Section 3.4](#).

##### Polyvinyl Chloride (PVC)

Sometimes referred to simply as “vinyl,” PVC does not usually exhibit extremely high- and low-temperature properties in one formulation. Certain formulations may have a  $-55^{\circ}\text{C}$  to  $105^{\circ}\text{C}$  rating, while other common vinyls may have a  $-20^{\circ}\text{C}$  to  $60^{\circ}\text{C}$  rating. The many varieties of PVC also differ in pliability and electrical properties. The price range can vary accordingly. Typical dielectric constant values range from 3.5 to 6.5.

When properly formulated, thermoplastic jackets of PVC provide cables with the ability to resist oils, acids, alkalis, sunlight, heat, weathering and abrasion. This range of properties makes PVC a suitable outer covering for such cable types as underground feeders (Type UF), control, aerial, street lighting and cables for direct burial.

PVC is frequently used as an impervious jacket over and/or under metal armor where the installation requires PVC's protective characteristics. Flam arrest is a plenum-grade, PVC-based jacketing material with low smoke and low flame spread properties.

##### Fluoropolymers

Fluoropolymers, with the exception of PTFE Teflon, are extrudable thermoplastics used in a variety of low-voltage insulating situations. Fluoropolymers contain fluorine in their molecular composition, which contributes to their excellent thermal, chemical, mechanical and electrical characteristics. The most commonly used fluoropolymers are Teflon (PTFE, FEP and PFA), Tefzel (ETFE), Halar (ECTFE) and Kynar or Solef (PVDF).

Teflon has excellent electrical properties, temperature range and chemical resistance. It is not suitable where subjected to nuclear radiation and does not have good high-voltage characteristics. FEP Teflon is extrudable in a manner similar to PVC and polyethylene. This means that long wire and cable lengths are available. PTFE Teflon is only extrudable in a hydraulic ram type process. Lengths are limited due to the amount of material in the ram, the thickness of the insulation and the preform size. PTFE must be extruded over a silver- or nickel-coated wire. The nickel- and silver-coated designs are rated  $260^{\circ}\text{C}$  and  $200^{\circ}\text{C}$  maximum, respectively. The cost of Teflon is approximately 8 to 10 times more per pound than PVC compounds.

Teflon PTFE is the original Teflon resin invented by DuPont in 1938. It is an opaque, white material, although some forms are translucent in thin sections. It does not melt in the usual sense. To coat wire for insulating purposes, Teflon PTFE is extruded around the conductor as a paste, then sintered. Conductors can also be wrapped with tape of Teflon PTFE. Maximum continuous service temperature of Teflon PTFE is  $260^{\circ}\text{C}$  ( $500^{\circ}\text{F}$ ).

Specific advantages of wire insulated with Teflon PTFE include:

- Nonflammability
- Extremely high insulation resistance
- Very low dielectric constant
- Small size compared to elastomer insulated wires
- Excellent lubricity for easier installation
- Chemical inertness.

Teflon FEP was also invented by DuPont and became commercially available in 1960. It has a glossy surface and is transparent in thin sections. Teflon FEP is a true thermoplastic. Wire insulated with Teflon FEP can be melt extruded by conventional methods. Maximum continuous service temperature is 400°F (205°C). Teflon FEP is an excellent nonflammable jacketing material for multiconductor cables.

Specific advantages of wire insulated with Teflon FEP include:

- High current carrying ability (ampacity)
- Easy color coding
- Smallest diameter of any high-temperature wire
- Nonflammability
- Very low moisture absorption.

Teflon PFA is a perfluoroalkoxy copolymer resin supplied by DuPont. Wire insulated with PFA is rated up to 250°C (482°F) and has excellent high-temperature creep resistance, low-temperature toughness and flame resistance.

Tefzel (ETFE) is commonly used in computer backplane wiring and has the highest abrasion and cut-through resistance of any fluoropolymer. Tefzel is a thermoplastic material having excellent electrical properties, heat resistance, chemical resistance, toughness, radiation resistance and flame resistance. Tefzel's temperature rating is -65°C to 150°C.

Halar (ECTFE) is similar to Tefzel and is also used in wirewrap applications, but because it is less expensive than Tefzel, it is often used as insulation on multipair plenum telephone cables. It has a maximum operating temperature of 125°C (UL). Halar has excellent chemical resistance, electrical properties, thermal characteristics and impact resistance. Halar's temperature rating is -70°C to 150°C.

Kynar (PVDF) is one of the least expensive fluoropolymers and is frequently used as a jacketing material on plenum cables. Because of its high dielectric constant, however, it tends to be a poor insulator. PVDF has a temperature maximum of 135°C (UL).

#### **Polyolefins (PO)**

Polyolefin is the name given to a family of polymers. The most common polyolefins used in wire and cable include polyethylene (PE), polypropylene (PP) and ethylene vinyl acetate (EVA).

#### **Polyethylene (PE)**

Polyethylene has excellent electrical properties. It has a low dielectric constant, a stable dielectric constant over a wide frequency range, and very high insulation resistance. However, polyethylene is stiff and very hard, depending on molecular weight and density. Low density PE (LDPE) is the most flexible, with high-density, high-molecular weight formulations being least flexible. Moisture resistance is excellent. Properly formulated PE has excellent weather resistance. The dielectric constant is 2.3 for solid and 1.6 for cellular (foamed) insulation. Flame retardant formulations are available, but they tend to have poorer electrical properties.

#### **Polypropylene (PP)**

Similar in electrical properties to polyethylene, this material is primarily used as an insulation material. Typically, it is harder than polyethylene. This makes it suitable for thin wall insulations. The UL maximum temperature rating may be 60°C or 80°C, but most UL styles call for 60°C maximum. The dielectric constant is typically 2.25 for solid and 1.55 for cellular designs.

#### **Thermoplastic Elastomer (TPE)**

TPE, sometimes called TPR (thermoplastic rubber), has excellent cold-temperature characteristics, making it an excellent insulating and jacketing compound in cold climates. It is resistant to aging from sunlight, oxidation and atmospheric ozone. It retains most of its physical and electrical properties in the face of many severe environmental conditions such as a salt water environment. TPE compounds can be rated as high as 125°C (257°F).

TPE has good chemical resistance to all substances except hydrocarbons. It has a tendency to swell in a hydrocarbon environment, causing the material to degrade. It has good abrasion resistance. It will resist wear, cutting and impact. These properties make TPE jackets an excellent choice for use in control cables that are dragged around or frequently moved.

TPE compounds are used as insulating materials up to a 600-volt rating. The most common cables using TPE insulation are portable control cables such as SEO and SJEQ.

#### **Polyurethane (PUR)**

Polyurethane is used primarily as a cable jacket material. It has excellent oxidation, oil and ozone resistance. Some formulations also have good flame resistance. It has excellent abrasion resistance. It has outstanding "memory" properties, making it an ideal jacket material for retractile cords.

#### 3.2.2 Thermosets

##### **Chlorinated Polyethylene (CPE)**

Cross-linked chlorinated polyethylene is a material with outstanding physical and electrical properties for many cable jacket applications. It is highly resistant to cold flow (compression set) and other forms of external loading as well as heat, light and chemical attack. CPE is also often supplied in a thermoplastic (non-cross-linked) version.

CPE compares favorably with most other synthetic elastomers currently used for cable jacketing. It is resistant to ozone and ultraviolet (sunlight) degradation. Properly compounded, CPE will withstand prolonged immersion in water. It will not support combustion, but under the right conditions of excessive heat, oxygen supply and flame source, it will burn slowly. Removal of the ignition source will extinguish the flame. CPE jacketed cables pass the IEEE 1202, UL, CSA and ICEA flame tests.

CPE maintains its flexibility at  $-18^{\circ}\text{C}$  ( $0^{\circ}\text{F}$ ) and does not become brittle unless temperatures are below  $-40^{\circ}\text{C}$  ( $-40^{\circ}\text{F}$ ). Its low temperature impact resistance is excellent. CPE jackets are suited to  $105^{\circ}\text{C}$  ( $221^{\circ}\text{F}$ ) and intermittently to higher temperatures. They will maintain adequate flexibility after repeated aging at elevated temperatures. They are known for abrasion resistance and long life in mining cable applications. CPE does not support the growth of mold, mildew or fungus.

CPE is resistant to most strong acids and bases and many solvents except for chlorinated organics. It is particularly well-suited to chemical plant use where both above ground (ultraviolet and flame retardancy) and below ground (water and chemical resistance) properties are desired. CPE's resistance to oils and fuels is good. CPE can be conveniently colored over a wide range and will maintain color upon aging.

##### **Neoprene (CP)**

Neoprene is a vulcanized synthetic rubber also referred to as chloroprene. It provides a resilient jacket that resists permanent deformation under heat and load, and does not embrittle at low temperatures. It is highly resistant to aging from sunlight and oxidation, and is virtually immune to atmospheric ozone.

Samples of neoprene-jacketed cable, tested outdoors under constant exposure for 40 years, have remained tough, resilient, uncracked and completely serviceable. Neoprene jackets are "flame resistant," i.e., not combustible without directly applied heat and flame. Neoprene will burn slowly as long as an outside source of flame is applied, but is self-extinguishing as soon as the flame is removed. Neoprene-jacketed power cable can be flexed without damage to the jacket at  $-40^{\circ}\text{C}$  ( $-40^{\circ}\text{F}$ ) and will pass a mandrel wrap test down to about  $-45^{\circ}\text{C}$  ( $-49^{\circ}\text{F}$ ). Neoprene jackets resist degradation for prolonged periods at temperatures up to  $121^{\circ}\text{C}$  ( $250^{\circ}\text{F}$ ). Satisfactory performance at even higher temperatures is possible if the exposures are brief or intermittent.

Neoprene jackets have excellent resistance to soil acids and alkalis. Mildew, fungus and other biological agents do not deteriorate properly compounded neoprene. These jackets perform well in many chemical plants. They are tough, strong, resilient and have excellent resistance to abrasive wear, impact, crushing and chipping. Because of these properties, neoprene is the jacketing material frequently used for mine trailing cables and dredge cables.

##### **Cross-linked Polyethylene (XLP or XLPE)**

Cross-linked polyethylene is a frequently used polymer in wire and cable. It is most often used as the insulation of 600 volt building wire (e.g., Type XHHW), as the insulation in 5 to 69 kV and higher rated power cables and as the insulation in many control cables.

XLP has very high insulation resistance (IR), high dielectric strength and low dielectric constant (2.3). It also is a very tough material at temperatures below  $100^{\circ}\text{C}$ , so it is resistant to cutting, impact and other mechanical forces. Its low-temperature performance is also very good: down to  $-40^{\circ}\text{C}$  and below. XLP's fire resistance, however, is poor unless flame retardants are added. XLP is lower in cost than EPR.



### Ethylene Propylene Rubber (EP, EPR, or EPDM)

Ethylene propylene rubber is a common synthetic rubber polymer used as an insulation in electrical wire and cable. EPR is used as the insulation in 600 volt through 69 kV power cables, as an integral insulation/jacket on welding cables and as an insulation in many cords, portable mining cables and control/instrumentation cables.

Because of its rubber-like characteristics, EPR is used in many highly flexible cables. Its dielectric strength is good but not as high as that of PE or XLP. Dielectric constant ranges from 2.8 to 3.2 depending on the specific EPR formulation. EPR is abrasion resistant and is suitable for use at temperatures down to  $-60^{\circ}\text{C}$ . It is fairly flame retardant and can be made even more flame retardant by careful formulation. Flame retardant versions are often referred to as "FREPP" or "flame retardant EP." EPR's high-temperature characteristics are very good. Some formulations can withstand continuous temperatures as high as  $150^{\circ}\text{C}$ .

### CSPE

Chlorosulfonated polyethylene is a thermosetting, cross-linked material with many excellent physical and electrical properties. It is inherently resistant to cold flow (compression set) resulting from clamping pressures and other forms of external loading; it is immune to attack by ozone; and it is highly resistant to aging from sunlight and oxidation. Water absorption of properly compounded CSPE cable sheathing is extremely low.

CSPE sheathing will not support combustion. It will burn slowly as long as an outside source of flame is applied but is self-extinguishing as soon as the flame is removed. It remains flexible at  $-18^{\circ}\text{C}$  ( $0^{\circ}\text{F}$ ) and will not become brittle at  $-40^{\circ}\text{C}$  ( $-40^{\circ}\text{F}$ ). CSPE jacketed constructions pass both the Underwriters Laboratories' vertical flame test and the U.S. Bureau of Mines' flame test for mining cable.

At high temperatures, CSPE will perform satisfactorily after short-term exposure at up to  $148^{\circ}\text{C}$  ( $300^{\circ}\text{F}$ ) – even higher if compounded for maximum heat resistance. It is well-known for its resistance to chemicals, oils, greases and fuels. It is particularly useful as a cable sheathing in plant processing areas, where airborne chemicals attack ordinary jacketing materials and metal conduit.

CSPE surpasses most elastomers in resistance to abrasion. It is highly resistant to attack by hydrocarbon oils and fuels. It is especially useful in contact with oils at elevated temperatures. Sheathing of CSPE provides high resistance to impact, crushing and chipping. CSPE's electrical properties make it appropriate as insulation for low-voltage applications (up to 600 volts) and as jacketing for any type of wire and cable.

CSPE was formerly sold by DuPont under the trade name "Hypalon". DuPont has since discontinued Hypalon manufacturing. To replace Hypalon after all existing supply is exhausted, cable manufacturers are either changing jackets to a "performance-based" equivalent thermoset material like thermoset chlorinated polyethylene (TS-CPE) or searching for other global sources for CSPE resin.

### Silicone

Silicone is a soft, rubbery insulation that has a temperature range from  $-80^{\circ}\text{C}$  to  $200^{\circ}\text{C}$ . It has excellent electrical properties plus ozone resistance, low moisture absorption, weather resistance, and radiation resistance. It typically has low mechanical strength and poor scuff resistance.

#### 3.2.3 Fibrous Coverings

Fibrous coverings are commonly used on high-temperature cables due to their excellent heat resistance. They are normally constructed of a textile braid (e.g., fiberglass or K-fiber) impregnated with a flame and heat-resistant finish.

K-fiber insulating materials are a blend of polyaramid, polyamid, phenolic-based and fiberglass fibers. They are available as roving and yarn for insulating applications and as rope for use as fillers. They provide a non-asbestos, abrasion-, moisture-, flame- and temperature-resistant, non-melting insulating material for all applications requiring a  $250^{\circ}\text{C}$  ( $482^{\circ}\text{F}$ ) temperature rating, which would have previously utilized asbestos.

#### 3.2.4 Additional Information

Additional information on the selection of cable jackets is available in IEEE 532 "Guide for Selecting and Testing Jackets for Power, Instrumentation and Control Cables."

### 3.3 COLOR CODING

#### 3.3.1 Power, Control, Instrumentation and Thermocouple

ICEA standard S-73-532 (NEMA WC57-2004) contains eleven methods for providing color coding in multiconductor cables. Methods 1, 3 and 4 are the most widely used.

Method 1 – Colored compounds with tracers

Method 2 – Neutral colored compounds with tracers

Method 3 – Neutral or single-color compounds with surface printing of numbers and color designations

Method 4 – Neutral or single-color compounds with surface printing of numbers

Method 5 – Individual color coding with braids

Method 6 – Layer identification

Method 7 – Silicone rubber insulated cables

Methods 8, 8A, 8B – Paired conductors

Method 9 – Color compounds with numbers – paired conductors

Methods 10, 10A and 11 – Thermocouple extension

cables – color coding of braidless conductors

Methods 11, 11A, 11B, 11C, 11D – Thermocouple extension

cables – color coding with braids

Historically, ICEA has established the sequence of colors used for Method 1 color coding, which consists of six basic colors, then a repeat of the colors with a colored band or tracer. This sequence of colors is referred to as K-1 color coding because it was formerly found in Table K-1 of many ICEA standards. In the latest ICEA standard the color sequences are located in Tables E-1 through E-8. (See Tables 3.1 through 3.8.)

The National Electrical Code (NEC) specifies that a conductor colored white can only be used as a grounded (neutral) conductor and that a conductor colored green can only be used as an equipment grounding conductor. The use of Table E-1 (formerly K-1) color coding would therefore be in violation of the Code in a cable having more than six conductors if conductors #7 (white/black), #9 (green/black), #14 (green/white), etc. are energized.

To address this issue, a different color coding sequence was developed by ICEA for cables that are used in accordance with the NEC. Table E-2 (formerly K-2) of the ICEA standard provides this color sequence. The ICEA standard provides further guidance stating that if a white conductor is required, this color may be introduced into Table E-2 as the second conductor in the sequence. If a green insulated conductor is required, it likewise can be introduced into the table. However, the white and green colors may only appear once.

The most popular multiconductor control cables in sizes 14 AWG–10 AWG have Method 1, Table E-2 color coding. The cables do not contain a white or green conductor. The most popular control cables used in sizes 8 AWG and larger are three conductor cables having black insulation surface ink printed with the numbers 1, 2 and 3. This is Method 4 color coding in the ICEA standards.

The electric utility industry often specifies control cables with the E-1 color coding sequence.

For applications where the NEC is applicable, such as in industrial and commercial applications, the E-2 color sequence is normally used.

ICEA S-82-552 (NEMA WC55) Instrumentation and Thermocouple Wire formerly contained methods and color sequence tables for instrumentation and thermocouple cables. This standard was withdrawn in 2002 and instrumentation and thermocouple wires were moved into ICEA S-73-532 (NEMA WC57) Standard for Control, Thermocouple Extension, and Instrumentation Wires.

The old standard contained tables titled E-1 through E-4 as well, but in a different order so the tables did not match WC57, this confusion no longer exists since the standards have been combined. The corresponding tables can be found in this chart:

S-82-552 (old)		S-73-532 (new)
E-1	Color sequence without white and green (NEC Applications)	E-2
E-2	Color sequence with white and green	E-1
E-3	Shades of Color	E-6
E-4	Thermocouple Extension Color	E-8

The ICEA has also published ICEA S-58-679 Control Cable Conductor Identification. This standard includes the same seven tables as WC57 but without using the E or K designation (e.g. Table 1) since they are not located within appendices in S-58-679 like in S-73-532.

Table 3.1—E-1 Color Sequence, including White and Green

Conductor Number	Background or Base Color	First Tracer Color	Second Tracer Color	Conductor Number	Background or Base Color	First Tracer Color	Second Tracer Color
1	Black	—	—	31	Green	Black	Orange
2	White	—	—	32	Orange	Black	Green
3	Red	—	—	33	Blue	White	Orange
4	Green	—	—	34	Black	White	Orange
5	Orange	—	—	35	White	Red	Orange
6	Blue	—	—	36	Orange	White	Blue
7	White	Black	—	37	White	Red	Blue
8	Red	Black	—	38	Black	White	Green
9	Green	Black	—	39	White	Black	Green
10	Orange	Black	—	40	Red	White	Green
11	Blue	Black	—	41	Green	White	Blue
12	Black	White	—	42	Orange	Red	Green
13	Red	White	—	43	Blue	Red	Green
14	Green	White	—	44	Black	White	Blue
15	Blue	White	—	45	White	Black	Blue
16	Black	Red	—	46	Red	White	Blue
17	White	Red	—	47	Green	Orange	Red
18	Orange	Red	—	48	Orange	Red	Blue
19	Blue	Red	—	49	Blue	Red	Orange
20	Red	Green	—	50	Black	Orange	Red
21	Orange	Green	—	51	White	Black	Orange
22	Black	White	Red	52	Red	Orange	Black
23	White	Black	Red	53	Green	Red	Blue
24	Red	Black	White	54	Orange	Black	Blue
25	Green	Black	White	55	Blue	Black	Orange
26	Orange	Black	White	56	Black	Orange	Green
27	Blue	Black	White	57	White	Orange	Green
28	Black	Red	Green	58	Red	Orange	Green
29	White	Red	Green	59	Green	Black	Blue
30	Red	Black	Green	60	Orange	Green	Blue

Note: The former K-1 color sequence was the same as E-1 through conductor number 21. K-1 then repeated.

### 3. Insulation and Jacket Materials

**Table 3.2–E-2 Color Sequence without White and Green**

Conductor Number	Background or Base Color	Tracer Color
1	Black	—
2	Red	—
3	Blue	—
4	Orange	—
5	Yellow	—
6	Brown	—
7	Red	Black
8	Blue	Black
9	Orange	Black
10	Yellow	Black
11	Brown	Black
12	Black	Red
13	Blue	Red
14	Orange	Red
15	Yellow	Red
16	Brown	Red
17	Black	Blue
18	Red	Blue
19	Orange	Blue
20	Yellow	Blue
21	Brown	Blue
22	Black	Orange
23	Red	Orange
24	Blue	Orange
25	Yellow	Orange
26	Brown	Orange
27	Black	Yellow
28	Red	Yellow
29	Blue	Yellow
30	Orange	Yellow
31	Brown	Yellow
32	Black	Brown
33	Red	Brown
34	Blue	Brown
35	Orange	Brown
36	Yellow	Brown

**Table 3.3–E-3 Color Sequence Including White And Green**

Conductor Number	First Tracer Color (e.g., Wide Tracer)	Second Tracer Color (e.g., Narrow Tracer)
1	Black	—
2	White	—
3	Red	—
4	Green	—
5	Orange	—
6	Blue	—
7	White	Black
8	Red	Black
9	Green	Black
10	Orange	Black
11	Blue	Black
12	Black	White
13	Red	White
14	Green	White
15	Blue	White
16	Black	Red
17	White	Red
18	Orange	Red
19	Blue	Red
20	Red	Green
21	Orange	Green

Table 3.4—E-4 Color Sequence Without White And Green

Conductor Number	First Tracer Color (e.g., Wide Tracer)	Second Tracer Color (e.g., Narrow Tracer)
1	Black	—
2	Red	—
3	Blue	—
4	Orange	—
5	Yellow	—
6	Brown	—
7	Red	Black
8	Blue	Black
9	Orange	Black
10	Yellow	Black
11	Brown	Black
12	Black	Red
13	Blue	Red
14	Orange	Red
15	Yellow	Red
16	Brown	Red
17	Black	Blue
18	Red	Blue
19	Orange	Blue
20	Yellow	Blue
21	Brown	Blue
22	Black	Orange
23	Red	Orange
24	Blue	Orange
25	Yellow	Orange
26	Brown	Orange
27	Black	Yellow
28	Red	Yellow
29	Blue	Yellow
30	Orange	Yellow
31	Brown	Yellow
32	Black	Brown
33	Red	Brown
34	Blue	Brown
35	Orange	Brown
36	Yellow	Brown

Table 3.5—E-5 Color Sequence For Braids, Including White And Green

Conductor Number	Background or Base Color	First Tracer Color	Second Tracer Color
1	Black	—	—
2	White	—	—
3	Red	—	—
4	Green	—	—
5	Orange	—	—
6	Blue	—	—
7	White	Black	—
8	Red	Black	—
9	Green	Black	—
10	Orange	Black	—
11	Blue	Black	—
12	Black	White	—
13	Red	White	—
14	Green	White	—
15	Blue	White	—
16	Black	Red	—
17	White	Red	—
18	Orange	Red	—
19	Blue	Red	—
20	Red	Green	—
21	Orange	Green	—
22	Black	White	Red
23	White	Black	Red
24	Red	Black	White
25	Green	Black	White
26	Orange	Black	White
27	Blue	Black	White
28	Black	Red	Green
29	White	Red	Green
30	Red	Black	Green
31	Green	Black	Orange
32	Orange	Black	Green
33	Blue	White	Orange
34	Black	White	Orange
35	White	Red	Orange
36	Orange	White	Blue
37	White	Red	Blue

Table 3.6—Shades of Color

Color	Munsell	Munsell
Black	N2	
White	N9	
Red	2.5 R	4/12
Blue	2.5 PB	4/10
Green	2.5 G	5/12
Orange	2.5 YR	6/14
Yellow	5 Y	8.5/12
Brown	2.5 YR	3.5/6

Table 3.7—Color Sequence for Silicone Rubber Insulated Cables

Conductor Number	Background or base color	First Tracer Color	Second Tracer Color
1*	White		
2	White	Black	
3	White	Red	
4	White	Green	
5	White	Orange	
6	White	Blue	
7	White	Red	Black
8	White	Green	Black
9	White	Orange	Black
10	White	Blue	Black
11	White	Orange	Red
12	White	Blue	Red
13	White	Red	Green
14	White	Orange	Green
15	White	Orange	Blue
16	White	Blue	Green

\* This conductor is on the inside of the assembly

Table 3.8—Color Coding of Duplexed Insulated Thermocouple Extension Wire

Extension Wire Type			Color of Insulation		
Type	Positive	Negative	Overall	Positive	Negative*
T	TPX	TNX	Blue	Blue	Red
J	JPX	JNX	Black	White	Red
E	EPX	ENX	Purple	Purple	Red
K	KPX	KNX	Yellow	Yellow	Red
R or S	SPX	SNX	Green	Black	Red
B	BPX	BNX	Gray	Gray	Red

\* A tracer having the color corresponding to the positive wire code color may be used on the negative wire color code.

3.3.2 Belden Electronic Color Code

Table 3.9—Common Multiconductor Color Code (Belden Standard)

Conductor	Color
1	Black
2	White
3	Red
4	Green
5	Brown
6	Blue
7	Orange
8	Yellow
9	Purple
10	Gray
11	Pink
12	Tan

Table 3.10—Common Multipair Color Code (Belden Standard)

Pair No.	Color Combination	Pair No.	Color Combination
1	Black and Red	20	White and Yellow
2	Black and White	21	White and Brown
3	Black and Green	22	White and Orange
4	Black and Blue	23	Blue and Yellow
5	Black and Yellow	24	Blue and Brown
6	Black and Brown	25	Blue and Orange
7	Black and Orange	26	Brown and Yellow
8	Red and White	27	Brown and Orange
9	Red and Green	28	Orange and Yellow
10	Red and Blue	29	Purple and Orange
11	Red and Yellow	30	Purple and Red
12	Red and Brown	31	Purple and White
13	Red and Orange	32	Purple and Dark Green
14	Green and White	33	Purple and Light Blue
15	Green and Blue	34	Purple and Yellow
16	Green and Yellow	35	Purple and Brown
17	Green and Brown	36	Purple and Black
18	Green and Orange	37	Gray and White
19	White and Blue		

Table 3.11—Belden Color Code Charts Nos. 2 (Spiral Stripe) and 2R (Ring Band Striping)\*

Cond. No.	Color	Cond. No.	Color	Cond. No.	Color	Cond. No.	Color
1	Black	14	Green/White Stripe	27	Blue/Black/White	40	Red/White/Green
2	White	15	Blue/White Stripe	28	Black/Red/Green	41	Green/White/Blue
3	Red	16	Black/Red Stripe	29	White/Red/Green	42	Orange/Red/Green
4	Green	17	White/Red Stripe	30	Red/Black/Green	43	Blue/Red/Green
5	Orange	18	Orange/Red Stripe	31	Green/Black/Orange	44	Black/White/Blue
6	Blue	19	Blue/Red Stripe	32	Orange/Black/Green	45	White/Black/Blue
7	White/Black Stripe	20	Red/Green Stripe	33	Blue/White/Orange	46	Red/White/Blue
8	Red/Black Stripe	21	Orange/Green Stripe	34	Black/White/Orange	47	Green/Orange/Red
9	Green/Black Stripe	22	Black/White/Red	35	White/Red/Orange	48	Orange/Red/Blue
10	Orange/Black Stripe	23	White/Black/Red	36	Orange/White/Blue	49	Blue/Orange/Red
11	Blue/Black Stripe	24	Red/Black/White	37	White/Red/Blue	50	Black/Orange/Red
12	Black/White Stripe	25	Green/Black/White	38	Black/White/Green		
13	Red/White Stripe	26	Orange/Black/White	39	White/Black/Green		

\* Based on ICEA Standard S-73-532/NEMA WC57

### 3. Insulation and Jacket Materials

**Table 3.12—Belden Color Code Chart No. 4**

Pair No.	Color Combination	Pair No.	Color Combination	Pair No.	Color Combination	Pair No.	Color Combination	Pair No.	Color Combination
1	White & Blue	6	Red & Blue	11	Black & Blue	16	Yellow & Blue	21	Purple & Blue
2	White & Orange	7	Red & Orange	12	Black & Orange	17	Yellow & Orange	22	Purple & Orange
3	White & Green	8	Red & Green	13	Black & Green	18	Yellow & Green	23	Purple & Green
4	White & Brown	9	Red & Brown	14	Black & Brown	19	Yellow & Brown	24	Purple & Brown
5	White & Gray	10	Red & Gray	15	Black & Gray	20	Yellow & Gray	25	Purple & Gray

**Table 3.13—Belden Color Code Chart No. 5**

Pair No.	Color Combination	Pair No.	Color Combination	Pair No.	Color Combination	Pair No.	Color Combination	Pair No.	Color Combination
1	White/Blue Stripe & Blue/White Stripe	6	Red/Blue Stripe & Blue/Red Stripe	11	Black/Blue Stripe & Blue/Black Stripe	16	Yellow/Blue Stripe & Blue/Yellow Stripe	21	Purple/Blue Stripe & Blue/Purple Stripe
2	White/Orange Stripe & Orange/White Stripe	7	Red/Orange Stripe & Orange/Red Stripe	12	Black/Orange Stripe & Orange/Black Stripe	17	Yellow/Orange Stripe & Orange/Yellow Stripe	22	Purple/Orange Stripe & Orange/Purple Stripe
3	White/Green Stripe & Green/White Stripe	8	Red/Green Stripe & Green/Red Stripe	13	Black/Green Stripe & Green/Black Stripe	18	Yellow/Green Stripe & Green/Yellow Stripe	23	Purple/Green Stripe & Green/Purple Stripe
4	White/Brown Stripe & Brown/White Stripe	9	Red/Brown Stripe & Brown/Red Stripe	14	Black/Brown Stripe & Brown/Black Stripe	19	Yellow/Brown Stripe & Brown/Yellow Stripe	24	Purple/Brown Stripe & Brown/Purple Stripe
5	White/Gray Stripe & Gray/White Stripe	10	Red/Gray Stripe & Gray/Red Stripe	15	Black/Gray Stripe & Gray/Black Stripe	20	Yellow/Gray Stripe & Gray/Yellow Stripe	25	Purple/Gray Stripe & Gray/Purple

**Table 3.14—Belden Color Code Chart No. 6**

Position No.	Color	Position No.	Color
1	Brown	13	White/Orange
2	Red	14	White/Yellow
3	Orange	15	White/Green
4	Yellow	16	White/Blue
5	Green	17	White/Purple
6	Blue	18	White/Gray
7	Purple	19	White/Black/Brown
8	Gray	20	White/Black/Red
9	White	21	White/Black/Orange
10	White/Black	22	White/Black/Yellow
11	White/Brown	23	White/Black/Green
12	White/Red	24	White/Black/Blue

**Table 3.15—Belden Color Code Chart No. 9: IBM RISC System/6000**

Cond No.	Color	Pair No.	Color
1	White over Blue	1	White over Blue & Blue over White
2	White over Orange	2	White over Orange & Orange over White
3	White over Green		
4	White over Brown		
5	White over Gray	3	White over Green & Green over White
6	White over Red		
7	White over Yellow		

**Table 3.16—Belden Color Code Chart No. 10: Fiber Optics\***

Cond No.	Color
1	Blue
2	Orange
3	Green
4	Brown
5	Gray
6	White
7	Red
8	Black
9	Yellow
10	Purple
11	Rose
12	Aqua

\*Per ANSI/TIA 598-A



Table 3.17—Belden Color Code Chart No. 7 for Snake Cables

Pair No.	Color Combination	Pair No.	Color Combination	Pair No.	Color Combination	Pair No.	Color Combination
1	Brown	16	Gray/Yellow Stripe	31	Blue/Purple Stripe	46	Lime/Black Stripe
2	Red	17	Gray/Green Stripe	32	Blue/Gray Stripe	47	Lime/Tan Stripe
3	Orange	18	Gray/Blue Stripe	33	Blue/White Stripe	48	Lime/Pink Stripe
4	Yellow	19	Gray/Purple Stripe	34	Blue/Black Stripe	49	Aqua/Brown Stripe
5	Green	20	Gray/Gray Stripe	35	Blue/Tan Stripe	50	Aqua/Red Stripe
6	Blue	21	Gray/White Stripe	36	Blue/Pink Stripe	51	Aqua/Orange Stripe
7	Purple	22	Gray/Black Stripe	37	Lime/Brown Stripe	52	Aqua/Yellow Stripe
8	Gray	23	Gray/Tan Stripe	38	Lime/Red Stripe	53	Aqua/Green Stripe
9	White	24	Gray/Pink Stripe	39	Lime/Orange Stripe	54	Aqua/Blue Stripe
10	Black	25	Blue/Brown Stripe	40	Lime/Yellow Stripe	55	Aqua/Purple Stripe
11	Tan	26	Blue/Red Stripe	41	Lime/Green Stripe	56	Aqua/Gray Stripe
12	Pink	27	Blue/Orange Stripe	42	Lime/Blue Stripe	57	Aqua/White Stripe
13	Gray/Brown Stripe	28	Blue/Yellow Stripe	43	Lime/Purple Stripe	58	Aqua/Black Stripe
14	Gray/Red Stripe	29	Blue/Green Stripe	44	Lime/Gray Stripe	59	Aqua/Tan Stripe
15	Gray/Orange Stripe	30	Blue/Blue Stripe	45	Lime/White Stripe	60	Aqua/Pink Stripe

Table 3.18—Belden Color Code Chart No. 8 for DataTwist Cables

Pair No.	Color Combination	Pair No.	Color Combination	Pair No.	Color Combination	Pair No.	Color Combination	Pair No.	Color Combination
1	White/Blue Stripe & Blue	6	Red/Blue Stripe & Blue/Red Stripe	11	Black/Blue Stripe & Blue/Black Stripe	16	Yellow/Blue Stripe & Blue/Yellow Stripe	21	Purple/Blue Stripe & Blue/Purple Stripe
2	White/Orange Stripe & Orange	7	Red/Orange Stripe & Orange/Red Stripe	12	Black/Orange Stripe & Orange/Black Stripe	17	Yellow/Orange Stripe & Orange/Yellow Stripe	22	Purple/Orange Stripe & Orange/Purple Stripe
3	White/Green Stripe & Green	8	Red/Green Stripe & Green/Red Stripe	13	Black/Green Stripe & Green/Black Stripe	18	Yellow/Green Stripe & Green/Yellow Stripe	23	Purple/Green Stripe & Green/Purple Stripe
4	White/Brown Stripe & Brown	9	Red/Brown Stripe & Brown/Red Stripe	14	Black/Brown Stripe & Brown/Black Stripe	19	Yellow/Brown Stripe & Brown/Yellow Stripe	24	Purple/Brown Stripe & Brown/Purple Stripe
5	White/Gray Stripe & Gray/White Stripe	10	Red/Gray Stripe & Gray/Red Stripe	15	Black/Gray Stripe & Gray/Black Stripe	20	Yellow/Gray Stripe & Gray/Yellow Stripe	25	Purple/Gray Stripe & Gray/Purple

**3.3.3 Telecommunication Color Codes**

Individual telecommunication cable conductors are color-coded with solid colors (Table 3.17) or by applying a colored band of contrasting color to solid colored wires (Table 3.18). Bandmarking is used on inside wiring cable, plenum cable and switchboard cable. The color combinations are such that each wire is banded with the color of its mate. For example, in a blue and white pair, the blue wire has a white band and the white wire a blue band. Telephone wires (e.g., inside-outside station wire and distribution frame and jumper wire) that do not have paired constructions have solid color wires.

All colors must be readily distinguishable and lie within the Munsell color standard.

**Large Pair Count Cables**

In cables having more than 25 pairs, the pairs are arranged in groups, each containing a maximum of 25 pairs and wrapped with distinctively colored binder threads to permit distinction between groups.

**Table 3.19—Telecommunication Cable Color Code (Solid Colors)**

Pair No.	Tip	Ring
1	White	Blue
2	White	Orange
3	White	Green
4	White	Brown
5	White	Slate
6	Red	Blue
7	Red	Orange
8	Red	Green
9	Red	Brown
10	Red	Slate
11	Black	Blue
12	Black	Orange
13	Black	Green
14	Black	Brown
15	Black	Slate
16	Yellow	Blue
17	Yellow	Orange
18	Yellow	Green
19	Yellow	Brown
20	Yellow	Slate
21	Violet	Blue
22	Violet	Orange
23	Violet	Green
24	Violet	Brown
25	Violet	Slate

**Table 3.20—Telecommunication Cable Color Code (Band Marked)**

Pair No.	Tip	Ring
1	White-Blue	Blue-White
2	White-Orange	Orange-White
3	White-Green	Green-White
4	White-Brown	Brown-White
5	White-Slate	Slate-White
6	Red-Blue	Blue-Red
7	Red-Orange	Orange-Red
8	Red-Green	Green-Red
9	Red-Brown	Brown-Red
10	Red-Slate	Slate-Red
11	Black-Blue	Blue-Black
12	Black-Orange	Orange-Black
13	Black-Green	Green-Black
14	Black-Brown	Brown-Black
15	Black-Slate	Slate-Black
16	Yellow-Blue	Blue-Yellow
17	Yellow-Orange	Orange-Yellow
18	Yellow-Green	Green-Yellow
19	Yellow-Brown	Brown-Yellow
20	Yellow-Slate	Slate-Yellow
21	Violet-Blue	Blue-Violet
22	Violet-Orange	Orange-Violet
23	Violet-Green	Green-Violet
24	Violet-Brown	Brown-Violet
25	Violet-Slate	Slate-Violet
26	Red-White	White-Red

### 3.4 PROPERTIES

#### 3.4.1 Thermoplastic

Table 3.21—Properties of Thermoplastic Insulation and Jacket Materials

	PVC	Low-Density Polyethylene	Cellular Polyethylene	High-Density Polyethylene	Polypropylene
Oxidation resistance	E	E	E	E	E
Heat resistance	G-E	G	G	E	E
Oil resistance	F	G-E	G	G-E	F
Low-temperature flexibility	P-G	E	E	E	P
Weather, sun resistance	G-E	E	E	E	E
Ozone resistance	E	E	E	E	E
Abrasion resistance	F-G	G	F	E	F-G
Electrical properties	F-G	E	E	E	E
Flame resistance	E	P	P	P	P
Nuclear radiation resistance	F	G-E	G	G-E	F
Water resistance	F-G	E	E	E	E
Acid resistance	G-E	G-E	G-E	E	E
Alkali resistance	G-E	G-E	G-E	E	E
Gasoline, kerosene, etc. (aliphatic hydrocarbons) resistance	P	G-E	G	G-E	P-F
Benzol, toluol, etc. (aromatic hydrocarbons) resistance	P-F	P	P	P	P-F
Degreaser solvents (halogenated hydrocarbons) resistance	P-F	G	G	G	P
Alcohol resistance	G-E	E	E	E	E
Underground burial	P-G	G	F	E	E

P = Poor, F = Fair, G = Good, E = Excellent, O = Outstanding

These ratings are based on average performance of general purpose compounds. Any given property can usually be improved by the use of selective compounding.

Source: Belden

Continued >>

### 3. Insulation and Jacket Materials

**Table 3.21—Properties of Thermoplastic Insulation and Jacket Materials (Continued)**

	Cellular Polypropylene	Polyurethane	Nylon	CPE	Plenum PVC
Oxidation resistance	E	E	E	E	E
Heat resistance	E	G	E	E	G-E
Oil resistance	F	E	E	E	F
Low-temperature flexibility	P	G	G	E	P-G
Weather, sun resistance	E	G	E	E	G
Ozone resistance	E	E	E	E	E
Abrasion resistance	F-G	O	E	E-O	F-G
Electrical properties	E	P	P	E	G
Flame resistance	P	P	P	E	E
Nuclear radiation resistance	F	F	G	F-G	O
Water resistance	E	P-G	P-F	O	F
Acid resistance	E	F	P-E	E	G
Alkali resistance	E	F	E	E	G
Gasoline, kerosene, etc. (aliphatic hydrocarbons) resistance	P	P-G	G	E	P
Benzol, toluol, etc. (aromatic hydrocarbons) resistance	P	P-G	G	G-E	P-F
Degreaser solvents (halogenated hydrocarbons) resistance	P	P-G	G	E	P-F
Alcohol resistance	E	P-G	P	E	G
Underground burial	F	G	P	E-O	P

P = Poor, F = Fair, G = Good, E = Excellent, O = Outstanding

These ratings are based on average performance of general purpose compounds. Any given property can usually be improved by the use of selective compounding.

Source: Belden

Continued >>

Table 3.21—Properties of Thermoplastic Insulation and Jacket Materials (Continued)

	FEP	Tefzel (ETFE)	PTFE (TFE) Teflon	Solef/Kynar (PVDF)/PVF	Halar (ECTFE)
Oxidation resistance	O	E	O	O	O
Heat resistance	O	E	O	O	O
Oil resistance	O	O	E	E-O	E
Low-temperature flexibility	O	E	O	O	O
Weather, sun resistance	O	E	O	E-O	O
Ozone resistance	E	E	O	E	E
Abrasion resistance	E	E	O	E	E
Electrical properties	E	E	E	G-E	E
Flame resistance	O	G	E	E	E-O
Nuclear radiation resistance	P-G	E	P	E	E
Water resistance	E	E	E	E	E
Acid resistance	E	E	E	G-E	E
Alkali resistance	E	E	E	E	E
Gasoline, kerosene, etc. (aliphatic hydrocarbons) resistance	E	E	E	E	E
Benzol, toluol, etc. (aromatic hydrocarbons) resistance	E	E	E	G-E	E
Degreaser solvents (halogenated hydrocarbons) resistance	E	E	E	G	E
Alcohol resistance	E	E	E	E	E
Underground burial	E	E	E	E	E

P = Poor, F = Fair, G = Good, E = Excellent, O = Outstanding

These ratings are based on average performance of general purpose compounds. Any given property can usually be improved by the use of selective compounding.

Source: Belden

## 3.4.2 Thermoset

Table 3.22—Properties of Thermoset Insulation and Jacket Materials

	Neoprene	Chlorosulfonated Polyethylene (CSPE)	EPR (Ethylene Propylene Rubber)	XLPE	CPE	Silicone Rubber
Oxidation resistance	G	E	E	E	E	E
Heat resistance	G	E	E	G	E	O
Oil resistance	G	G	P	G	G-E	F-G
Low-temperature flexibility	F-G	F	G-E	O	F	O
Weather, sun resistance	G	E	E	G	E	O
Ozone resistance	G	E	E	G	G-E	O
Abrasion resistance	G-E	G	G	F-G	G-E	P
Electrical properties	P	G	E	E	F-G	G
Flame resistance	G	G	P	P	G	F-G
Nuclear radiation resistance	F-G	E	G	E	G	E
Water resistance	E	E	G-E	G-E	G-E	G-E
Acid resistance	G	E	G-E	G-E	E	F-G
Alkali resistance	G	E	G-E	G-E	E	F-G
Gasoline, kerosene, etc. (aliphatic hydrocarbons) resistance	G	F	P	F	F	P-F
Benzol, toluol, etc. (aromatic hydrocarbons) resistance	P-F	F	F	F	F	P
Degreaser solvents (halogenated hydrocarbons) resistance	P	P-F	P	F	P	P-G
Alcohol resistance	F	G	P	E	G-E	G
Underground burial	G-E	E	E	E	E	G

P = Poor, F = Fair, G = Good, E = Excellent, O = Outstanding

These ratings are based on average performance of general purpose compounds. Any given property can usually be improved by the use of selective compounding.

Source: Belden

3.4.3 EPR Versus XLPE

Table 3.23—Properties of EPR Compared with Those of XLPE

Cross-Linked Polyethylene (XLPE)	Ethylene Propylene Rubber (EPR)
Less deformation below 100°C	Less deformation above 100°C
Lower in cost	More heat resistance
Lower dissipation factor	Less shrinkback
Lower dielectric constant	Less thermal expansion
Higher dielectric strength	More corona resistant
Physically tougher	More flexible
More resistant to chemicals	More tree retardant
More oil resistant	More sunlight resistant

3.4.4 Thermal Characteristics

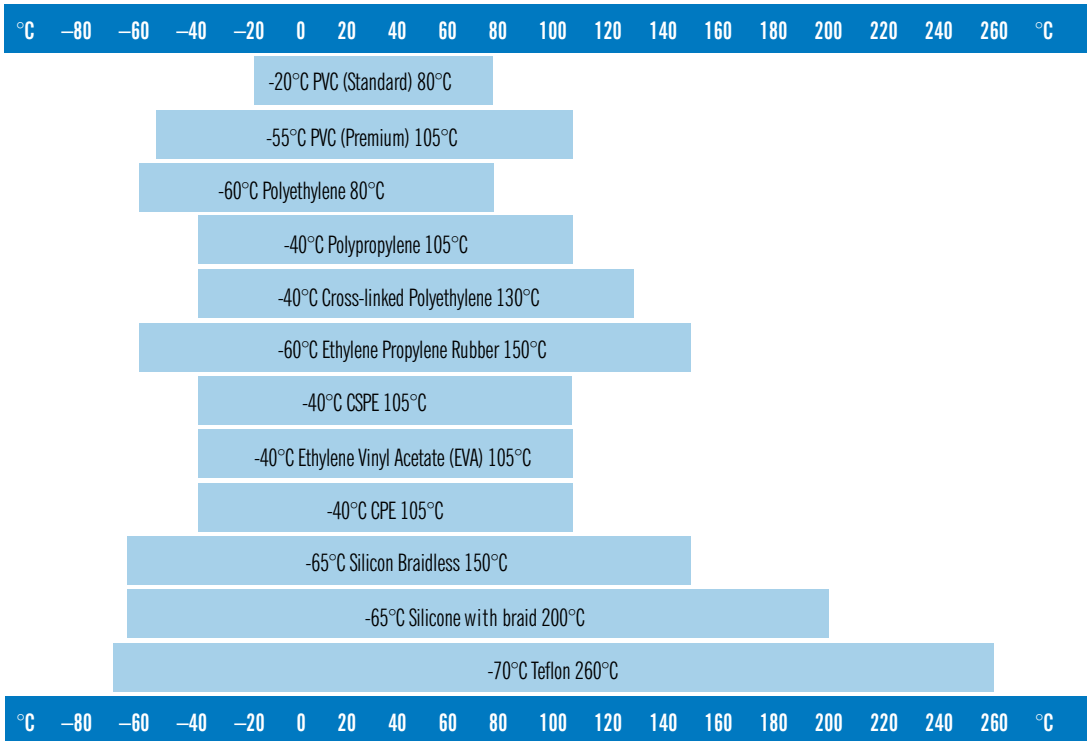

Figure 3.1—Nominal Temperature Range of Cable Polymers

3.4.5 Halogen Content

Table 3.24—Halogen Content in Typical Insulation and Jacket Materials

Material	Typical Halogen Content Percent by weight
PE insulation or jacket	<0.02
XLP insulation 600 V (6 AWG and larger)	<0.02
XLP insulation 5-35 kV	<0.02
EPR insulation 5-35 kV	<0.02
Polyurethane jacket	<0.02
EVA jacket	<0.02
XLP insulation 600 V (14-8 AWG)	7–13
FR-EPR insulation	9–14
CSPE (insulation grade)	13–16
FR-XLP insulation	11–17
CSPE jacket (heavy duty)	16–26
Neoprene jacket	16–18
CPE jacket	14–28
CSPE jacket (extra heavy duty)	18–33
PVC jacket	22–29

NOTE: Halogen content can vary from manufacturer to manufacturer. The above values should be used for general comparisons only.

3.4.6 Limiting Oxygen Index (LOI)

LOI values are used to determine the relative flammability of polymers. Tests are usually conducted in accordance with ASTM D2863, which finds the percentage of oxygen required to sustain combustion. Typical values are shown below. The oxygen content of air is 20.9 percent.

Table 3.25—LOI of Common Wire and Cable Materials

Material	Percent Oxygen	Material	Percent Oxygen
Teflon	93	Neoprene	32
PVDF (Kynar)	43–85	Tefzel	30–32
Halar	55	PVC	28–32
Plenum grade PVC	38–42	Kevlar	29
FR-EP	30–40	NBR PVC	28
FR-XLP	30–40	XLP (Unfilled)	20–23
CPE	28–36	PE (Unfilled)	20–23
Ethylene Vinyl Acetate (EVA)	32–35		
CSPE	34		



### 3.4.7 Dielectric Constant

**Table 3.26—Dielectric Constant of Common Wire and Cable Materials**

Material	Dielectric Constant
Teflon (FEP, PFA or TFE)	2.1
Polypropylene	2.2–2.3
Cross-linked Polyethylene	2.3
Polyethylene	2.3
TPE	2.3–2.5
Halar (ECTFE)	2.6
Tefzel (ETFE)	2.6
EPR	2.8–3.5
Ethylene Vinyl Acetate (EVA)	3.8

Material	Dielectric Constant
Polyester (Mylar)	3.3–3.8
Silicone	3–4
Nylon	3.2–5
Mica	6.9
PVC	3.5–8
Chlorosulfonated Polyethylene (CSPE)	8–10
Neoprene (PC) Polychloroprene	9–10
Kynar (PVDF)	6–12



# 4. SHIELDS

<b>4.1</b>	<b>Power Cable</b>	<b>56</b>
4.1.1	Conductor Shield (Strand Shield)	56
4.1.2	Outer Shield (Insulation Shield)	56
<b>4.2</b>	<b>Electronic Cable</b>	<b>58</b>
4.2.1	Foil Shield	58
4.2.2	Copper Braid Shield	59
4.2.3	Spiral (Serve) Shield	59

A shield is a metallic covering enclosing an insulated conductor or group of conductors. Though sometimes similar in appearance, shields for electronic and power cables perform very different functions. Electronic cable shields serve to both minimize the effect of external electromagnetic signals on the conductors in the cable and to reduce the radiated signal from the cable to an acceptable level. Power cable shields, on the other hand, help protect the user from shock hazards and increase cable reliability by preventing partial discharges (corona) in cables.

### 4.1 POWER CABLE

---

The use of shields in power cables reduces electrical shock hazard to people and provides uniform distribution of electrical stresses throughout the insulation. A uniform distribution of electrical stress extends the life of the cable by eliminating partial discharges. The NEC requires most cable rated 2,400 V or greater to be shielded. The various components of a power cable shield are discussed below.

#### 4.1.1 Conductor Shield (Strand Shield)

The nonround geometry of stranded conductors permits air gaps between the outer surface of the conductor and the inner surface of the insulation. Without a stress control layer, high electric fields cause partial discharges within these gaps, which can harm the insulation. Energetic ions bombard the insulation, break molecular bonds and degrade the insulation. Microscopic channels called “trees” may form and ultimately cause premature failure of the insulation. Thus, the primary purpose of the conductor shield is to provide a smooth, continuous and void-free interface between the conductor and insulation.

There are two basic types of conductor shields – “conductive” and “emission” shields. An emission shield uses a material with a high dielectric constant to do its job. The most popular type, however, is the conductive shield. It is a material (either an extruded carbon black loaded polymer or carbon black impregnated fabric tape) with electrical conductivity midway between that of a metallic conductor such as copper and that of an insulation such as XLP. Such a material is commonly referred to as a “semiconductive” shield (not to be confused with semiconductors, i.e., transistors, used in the electronics industry). AEIC document CS8 and ICEA publication T-25-425 contain detailed specifications on the electrical and physical performance of the conductor shield.

Semiconductive shields must be as smooth, cylindrical and clean as possible to avoid electrical stress concentrations that can lead to insulation damage.

#### 4.1.2 Outer Shield (Insulation Shield)

The insulation shield plays much the same role as the conductor shield in protecting the insulation from the damaging effects of corona, but at the outside of the cable’s insulation. It too must remain in intimate contact with the insulation and be free of voids and defects. The insulation shield material is either electrically conductive or made of a high dielectric constant material and provides a uniform electrical field within the insulation. The insulation shield also provides an important safety function at terminations and splices where the metallic part of the shield may not completely cover the cable insulation surface. Volume resistivity of the insulation shield is normally less than 500 ohm-meters.

### Copper Tape Shields

The copper tape used in power cable shields is usually 5 mils thick and 1 to 1 1/2 inches wide. It is generally helically applied over a semiconducting polymer insulation shield.

Power cables rated 5 to 35 kV and up frequently utilize copper tape as the metallic component of the metal/polymer shielding system. In combination with the extruded insulation shield, a copper tape shield increases insulation life by maintaining uniform electrical stress throughout the cable insulation and provides low end-to-end resistance of the shield system.

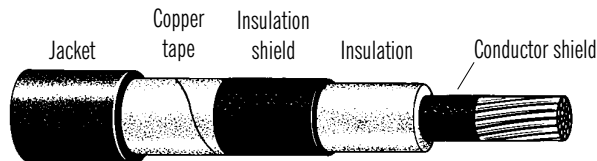

Figure 4.1—Typical Copper Tape Shielded Power Cable

Table 4.1—Power Cable Shielding

Advantages	Disadvantages
<ul style="list-style-type: none"> <li>• When properly grounded, provides protection from electrical shock</li> </ul>	<ul style="list-style-type: none"> <li>• Must be terminated with a medium-voltage termination to control electrical stresses</li> </ul>
<ul style="list-style-type: none"> <li>• Increases life of the cable insulation</li> <li>• Reduces electromagnetic interference (EMI)</li> </ul>	<ul style="list-style-type: none"> <li>• Higher cost</li> </ul>

### Wire Shields

Metallic wire shields on power cables come in two basic types: helically applied copper wires and UniShield.

Helically applied copper wire shields are sometimes used on 5 through 35 kV and higher rated power cables. They are sometimes used in combination with copper tape to provide additional shield fault current capacity.

UniShield cables have six corrugated copper wires longitudinally imbedded in a conducting CPE jacket. The wires can be used as “ripcords” to reduce termination time during installation.

## 4.2 ELECTRONIC CABLE

Electronic cable shielding provides an efficient way to manage electromagnetic interference (EMI).

When a shielded cable is present in an ambient electromagnetic field, an interference current is induced in the shield. The incident energy is partially reflected from the shield and partially absorbed by the shield and a small amount penetrates through the shield into the cable. The small amount of energy that makes it all the way through the shield generates an interference voltage in the signal carrying conductors of the cable. The smaller the interference voltage, the better the shield.

In addition to shielding effectiveness, electronic cable shields must satisfy a long list of electrical, mechanical, chemical and cost requirements. As a result, a diversified line of shield designs has evolved in the wire and cable industry.

### 4.2.1 Foil Shield

Foil shields are usually constructed of aluminum foil with a 1/2-mil thick polyester backing. This backing provides mechanical strength. The shield can be overlapped (Fig. 4.2) with the foil facing in or the foil facing out. This overlap creates a slot where signal leakage through the shield can occur. The “Z” fold (Fig. 4.3) construction provides the best electrical isolation between shields of adjacent pairs as well as 100 percent coverage. A tinned copper drain wire is placed in contact with the foil side of the shield to provide easier grounding of the shield at the cable terminations.

Foil shields are most common in electronic and coaxial cables. Foil shields provide excellent protection from electromagnetic interference, especially at high frequencies.

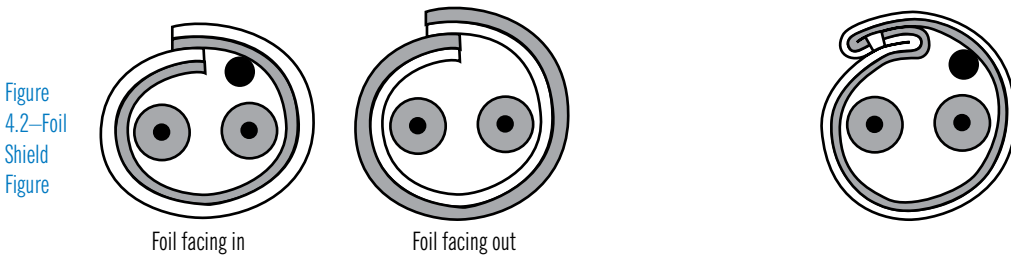

Figure 4.2—Foil Shield

### 4.3—Z-Fold Foil Shield

Table 4.2—Foil Shielding

Advantages	Disadvantages
<ul style="list-style-type: none"> <li>• 100 percent coverage</li> <li>• Low cost</li> <li>• Ease of termination</li> <li>• Good flexibility</li> <li>• Excellent shielding at high frequencies</li> </ul>	<ul style="list-style-type: none"> <li>• Poor mechanical strength</li> <li>• Short flex life</li> <li>• Less effective at low frequencies</li> </ul>

### 4.2.2 Copper Braid Shield

A braid shield typically consists of copper wire ranging in size from 32 to 40 AWG braided into a mesh around the cable core. The tightness of the braid determines the percent coverage. Typical coverage ranges from 60 percent to 90 percent. Generally, the higher the coverage the better the shield.

Braid shields are typically used on coaxial cables and on low-speed communication cables. Braid shields are most effective at low frequencies. Braid shields are also commonly used on cables where increased flex life and mechanical strength are required.

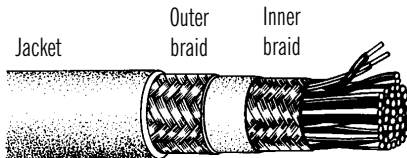

Figure 4.4—Dual Braid Shield Construction on a Multipair Cable

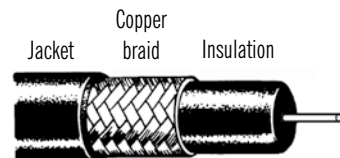

Figure 4.5—Copper Braid Construction on a Coaxial Cable

Table 4.3—Copper braid shields

Advantages	Disadvantages
<ul style="list-style-type: none"> <li>• Best at low frequencies</li> <li>• Good mechanical strength</li> <li>• Increased flex life</li> </ul>	<ul style="list-style-type: none"> <li>• Increased cost</li> <li>• More difficult to terminate</li> </ul>

### 4.2.3 Spiral (Serve) Shield

Spiral or serve shields, as they are sometimes called, are typically constructed with bare or tinned copper wires from 32 to 40 AWG in size that are helically applied in a flat or ribbon configuration (Fig. 4.6). Spiral shields range in coverage from 80 percent to about 97 percent.

Spiral shields are used primarily in audio, microphone and retractile cord cables where extreme flexibility and a long flex life are required. Spiral shields perform best when used at low (audio) frequencies.

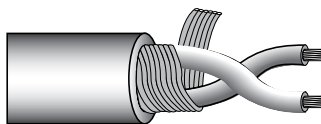

Figure 4.6—Spiral or Serve Shield

Table 4.4—Spiral Shields

Advantages	Disadvantages
<ul style="list-style-type: none"> <li>• Excellent flexibility</li> <li>• Long flex life</li> </ul>	<ul style="list-style-type: none"> <li>• Poor electrical performance at high frequencies</li> </ul>





# 5. ARMOR

5.1	Interlocked Armor	62
5.2	Continuously Corrugated and Welded (CCW)	62
5.3	Basket-Weave	63
5.4	Lead Sheath	63
5.5	Wire Serve	63

Cables often need to be placed in areas where they are subjected to harsh mechanical stresses. These stresses could damage the insulated conductors or the optical fibers in the cable if they are not properly protected. Armor (usually a metal) is frequently applied over the cable core to provide this protection. The armor extends the life, while improving the reliability, safety and performance of the cable core. The following are some frequently used armor types.

### 5.1 INTERLOCKED ARMOR

Interlocked armor typically uses galvanized steel or aluminum. However, other metals are sometimes used for specialized applications. The interlocking construction protects the cable from damage during and after installation. The armor may be applied directly over the insulation or over an inner jacket. Materials and construction generally comply with the requirements of UL, CSA and/or ICEA.

Table 5.1—ICEA Recommended Thickness of Interlocked Armor

Diameter of Cable (in.)	Nominal Thickness (mils)	
	Steel or Bronze	Aluminum
0 to 1.500	20	25
1.501 and larger	25	30

### 5.2 CONTINUOUSLY CORRUGATED AND WELDED (CCW)

Continuously corrugated and welded armor is made by forming an aluminum strip into a circle along its length and then welding it at the seam. This smooth tube is then rolled or crimped to form ridges to prevent kinking while bending (Fig. 5.1). This type of sheath provides an impervious seal against moisture and other chemicals as well as physical protection.

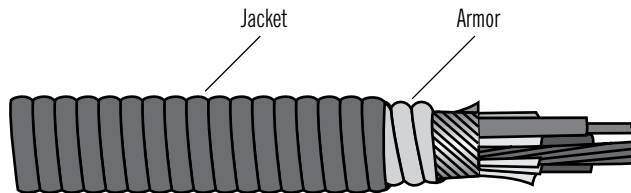

Figure 5.1—Continuously Corrugated and Welded (CCW) Armor

### 5.3 BASKET-WEAVE

Basket-weave armor is constructed of metal wires forming a braided outer covering. The wires may be of galvanized steel, aluminum or bronze. This armor is generally used on shipboard cables because it provides the mechanical protection of an armored cable, yet is much lighter in weight than other types of armored coverings. Materials and construction generally comply with the requirements of IEEE Standard 1580 and various military specifications. This type of armor is referred to as GSWB (galvanized steel wire braid) in some international standards.

### 5.4 LEAD SHEATH

For underground installations in conduits, ducts and raceways, a lead sheath may be used to protect insulated cables from moisture. In locations where corrosive conditions may be encountered, a jacket over the lead sheath is recommended.

Commercially pure lead is used on some lead-covered cables, which conforms to the requirements of ASTM B29 and ICEA S-93-639 (NEMA WC74). Lead alloy sheaths, containing added tin or antimony, are used where a harder sheath is desired or where vibration may be encountered.

### 5.5 WIRE SERVE

Wire serve armor is most commonly found on submarine cable because it provides excellent physical protection from boat anchors, sharp rocks, sharks, etc. This type of armor normally consists of 1/8- to 1/4-inch diameter solid steel wires, which are laid helically around the circumference of the cable. Tar or asphalt (bitumen) is placed over and around the steel wires to reduce the effects of corrosion. This type of armor is referred to as SWA (steel wire armor) in some international standards.



# 6. CABLE TYPES AND SELECTION CRITERIA

<b>6.1</b>	<b>Portable Power and Control</b>	<b>67</b>
	6.1.1 Flexible Cords	67
	6.1.2 Mining Cable	68
<b>6.2</b>	<b>Construction and Building Wire</b>	<b>68</b>
<b>6.3</b>	<b>Control, Instrumentation and Thermocouple</b>	<b>68</b>
	6.3.1 Control Cable	68
	6.3.2 Instrumentation Cable	69
	6.3.3 Thermocouple Wire	69
<b>6.4</b>	<b>High Temperature</b>	<b>70</b>
<b>6.5</b>	<b>Power</b>	<b>71</b>
	6.5.1 Voltage Rating	71
	6.5.2 Conductor Size	71
	6.5.3 Short Circuit Current	72
	6.5.4 Voltage Drop Considerations	72
	6.5.5 Special Conditions	73
<b>6.6</b>	<b>Armored Power and Control</b>	<b>73</b>
<b>6.7</b>	<b>Electronic Cable</b>	<b>73</b>
	6.7.1 Coaxial Cable	73
	6.7.2 Twinaxial Cable (Twinax)	75
	6.7.3 100 ohm Twisted Pair Cable	76
	6.7.4 IBM Cabling System	78

# 6. CABLE TYPES AND SELECTION CRITERIA

<b>6.8</b>	<b>Telephone</b>	<b>78</b>
6.8.1	Outside Cables	78
6.8.2	Indoor Cables	79
6.8.3	Insulation and Jacket Materials	79
<b>6.9</b>	<b>Military</b>	<b>80</b>
<b>6.10</b>	<b>Shipboard Cables (MIL-DTL-24643, MIL-DTL-24640 and MIL-DTL-915)</b>	<b>81</b>
<b>6.11</b>	<b>Optical Fiber Cables</b>	<b>81</b>
6.11.1	Fiber Types	81
6.11.2	Fiber Selection	82
6.11.3	Optical Fiber Cable Selection	82
<b>6.12</b>	<b>Tray Cables</b>	<b>84</b>

## 6.1 PORTABLE POWER AND CONTROL

### 6.1.1 Flexible Cords

Flexible cords come in a number of UL and CSA types including SO, SOW, SOOW, SJ, SJO, SJOW, STO and SJTO. In portable cord terminology, each letter of the cable type indicates the construction of the cable. For example: S = service, O = oil-resistant jacket, J = junior service (300 volts), W = weather resistant, T = thermoplastic, and OO = oil-resistant insulation and jacket.

The temperature rating of these cables can range from  $-50^{\circ}\text{C}$  to  $105^{\circ}\text{C}$  for SOOW and  $-40^{\circ}\text{C}$  to  $90^{\circ}\text{C}$  for other thermoset cords. Thermoplastic cords typically have temperature ratings that range from  $-20^{\circ}\text{C}$  to  $60^{\circ}\text{C}$ . Thermoset portable cords have excellent cold bend characteristics and are extremely durable.

**Table 6.1—Flexible Cord Type Designations**

TST	Tinsel Service Thermoplastic	SJTOO	SJTO with Oil-Resistant Insulation
SPT-1	Service Parallel Thermoplastic – 1/64 in. Insulation	SJTOOW	Weather-Resistant SJTOO
SPT-2	Service Parallel Thermoplastic – 2/64 in. Insulation	SJE	Service Junior Elastomer
SPT-3	Service Parallel Thermoplastic – 3/64 in. Insulation	SJEO	SJE with Oil-Resistant Jacket
SPE-1	Service Parallel Elastomer – 1/64 in. Insulation	SJEOO	SJEO with Oil-Resistant Insulation
SPE-2	Service Parallel Elastomer – 2/64 in. Insulation	SJEOOW	Weather Resistant SJEOO
SPE-3	Service Parallel Elastomer – 3/64 in. Insulation	S	Service
SV	Service Vacuum	SO	Service with Oil-Resistant Jacket
SVO	Service Vacuum Oil-Resistant Jacket	SOO	SO with Oil-Resistant Insulation
SVOO	SVO with Oil-Resistant Insulation	SOOW	Weather-Resistant SOO
SVT	Service Vacuum Thermoplastic	ST	Service Thermoplastic
SVTO	SVT with Oil-Resistant Jacket	STO	ST with Oil-Resistant Jacket
SVTOO	SVTO with Oil-Resistant Insulation	STOO	STO with Oil-Resistant Insulation
SVE	Service Vacuum Elastomer	STOOW	Weather-Resistant STOO
SVEO	SVE with Oil-Resistant Jacket	SE	Service Elastomer
SVEOO	SVEO with Oil-Resistant Insulation	SEO	SE with Oil-Resistant Jacket
SJ	Service Junior	SEOO	SEO with Oil-Resistant Insulation
SJO	SJ with Oil-Resistant Jacket	SEOOO	Weather-Resistant SEOO
SJOO	SJO with Oil-Resistant Insulation	HPN	Heater Parallel Neoprene
SJOOW	Weather Resistant SJOO	HSJ	Heater Service Junior
SJT	Service Junior Thermoplastic	HSJO	HSJ with Oil-Resistant Jacket
SJTO	SJT with Oil-Resistant Jacket		

## 6. Cable Types and Selection Criteria

### 6.1.2 Mining Cable

Mine power cables are generally designed to be used as flexible feeder cables for circuits between the main power source and mine load centers or as equipment trailing cables.

Mine power feeder (MPF) cables typically have voltage ratings of 5, 8, 15 or 25 kV and are available with or without a ground check conductor. A ground check (GC) conductor is a separate insulated ground wire that is used to monitor the “health” of the normal ground wire. MPF cables are flexible but are designed for only limited or occasional movement.

Shovel (SHD) cables are generally used to power heavy-duty mobile mining equipment. SHD cables are unique in that they not only carry voltage ratings up to 25 kV but also have great flexibility and incredible physical toughness. Like mine power cables, SHD cables are generally available with or without a ground check conductor.

For low-voltage applications, there are a number of portable cables used by the mining industry. Among the most common are Type W and Type G. Both cables are a heavy-duty construction, can withstand frequent flexing and carry a voltage rating of up to 2 kV.

## 6.2 CONSTRUCTION AND BUILDING WIRE

Construction and building wire encompasses a wide variety of 300- and 600-volt wire and cable including UL Types THW, THW-2, THWN, THWN-2, THHN, TFFN, TFN, RHH, RHW, RHW-2, USE, USE-2, thermostat wire, SER, SE-U, XHHW, XHHW-2 and others. This category of wire is typically used as the permanent wiring in residential, commercial and industrial facilities. UL types with a “-2” suffix are rated 90°C in both dry and wet locations. In building wire terminology, each letter of the wire type indicates something about the construction. For example:

THHN — Thermoplastic, high heat resistant, nylon jacket

THWN-2 — Thermoplastic, heat resistant, wet and dry locations (-2 means 90°C wet), nylon jacket

XHHW-2 — Cross-linked (X) insulation, high heat resistant, wet and dry locations (-2 means 90°C wet)

RHW-2 — Thermoset (rubber) insulation, high heat resistant, wet and dry locations (-2 means 90°C wet)

USE-2 — Underground Service Entrance wire (-2 means 90°C wet)

## 6.3 CONTROL, INSTRUMENTATION AND THERMOCOUPLE

### 6.3.1 Control Cable

Control cables differ from power cables in that they are used to carry intermittent control signals, which generally require little power. Therefore, current loading is rarely a deciding factor in the choice of control cable. Primary criteria that are applied to the selection of control cable are voltage level and environmental conditions. The voltage level for control circuits may range anywhere from millivolts up to several hundred volts.

#### Environmental Conditions

Control cables are generally subject to rather severe environmental conditions. For this reason an examination of these conditions is at least as important as electrical considerations. High ambient temperature conditions (such as near boilers and steam lines), along with possible exposure to oils, solvents and other chemicals (in chemical, petroleum, steel, pulp and paper and cement plants), are vital considerations.

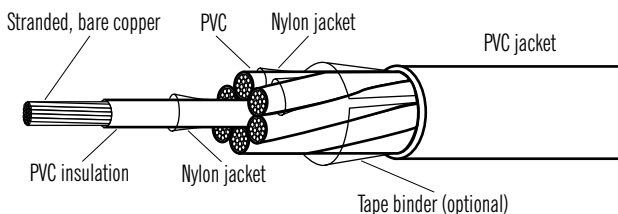

Figure 6.1—A Typical 600 V Control Cable



**6.3.2 Instrumentation Cable**

Instrumentation cable is generally used to transmit a low-power signal from a transducer (measuring for example, pressure, temperature, voltage, flow, etc.) to a PLC or DCS process control computer or to a manually operated control panel. It is normally available in 300- or 600-volt constructions with a single overall shield, or with individual shields over each pair (or triad) and an overall shield.

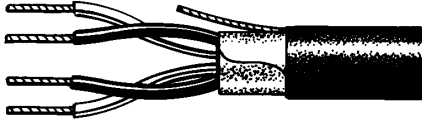

Figure 6.2—Control Cable with Overall Shield

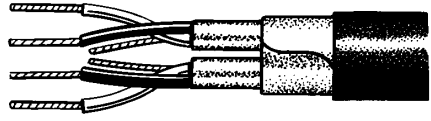

Figure 6.3—Control Cable with Individually Shielded Pairs and An Overall Shield

**6.3.3 Thermocouple Wire**

A thermocouple is a temperature measuring device consisting of two conductors of dissimilar metals or alloys that are connected together at one end. At this thermocouple junction, as it is called, a small voltage is produced. Electronic equipment senses this voltage and converts it to temperature. Thermocouple wire is available in either thermocouple grade or extension grade. Extension grade wire is normally lower in cost and is recommended for use in connecting thermocouples to the sensing or control equipment. The conditions of measurement determine the type of thermocouple wire and insulation to be used. Temperature range, environment, insulation requirements, response and service life should be considered. Note that thermocouple wire color codes can vary around the world.

**Thermocouple Types**

Type J (Iron vs Constantan) is used in vacuum, oxidizing, inert or reducing atmospheres. Iron oxidizes rapidly at temperatures exceeding 538°C (1,000°F), and therefore heavier gauge wire is recommended for longer life at these temperatures.

Type K (Chromel vs Alumel) is used in oxidizing, inert or dry reducing atmospheres. Exposure to a vacuum should be limited to short time periods. Must be protected from sulfurous and marginally oxidizing atmospheres. Reliable and accurate at high temperatures.

Type T (Copper vs Constantan) is used for service in oxidizing, inert or reducing atmospheres or in a vacuum. It is highly resistant to corrosion from atmospheric moisture and condensation and exhibits high stability at low temperatures; it is the only type with limits of error guaranteed for cryogenic temperatures.

Type E (Chromel vs Constantan) may be used in oxidizing, inert or dry reducing atmospheres, or for short periods of time under vacuum. Must be protected from sulfurous and marginally oxidizing atmospheres. Produces the highest EMF per degree of any standardized thermocouple.

Type R and S (Platinum vs Rhodium) are used in oxidizing or inert atmospheres. Must be protected from contamination. Reliable and accurate at high temperatures.

Thermocouple wire can be fabricated into an accurate and dependable thermocouple by joining the thermoelements at the sensing end.

Thermocouple wire or thermocouple extension wire of the same type must be used to extend thermocouples to indicating or control instrumentation. Red color code is negative throughout circuit.

Hook up red color-coded wire to negative terminal of instrument.

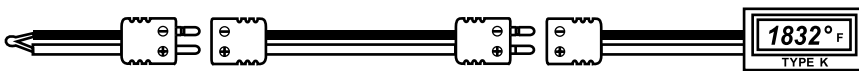

Temperature limit of the thermocouple depends on the thermocouple wire: wire size; wire insulation; and environmental factors.

Use thermocouple connectors if required. They are made of the same alloys and have the same color codes as extension wire.

Source: PMC Corporation

Figure 6.4—A Typical Thermocouple Circuit

**Table 6.2—Color Code for Thermocouple Wire Per ANSI/ISA MC96.1**

Thermocouple Type		Color Code	
Wire Alloys	ANSI Symbol	+/- Individual	Jacket
*Iron (1) vs Constantan (2)	J	White/Red	Brown
Chromel (1) vs *Alumel (2)	K	Yellow/Red	Brown
Copper (1) vs Constantan (2)	T	Blue/Red	Brown
Chromel (1) vs Constantan (2)	E	Purple/Red	Brown
Platinum (1) vs 13% Rhodium (2)	R	—	—
Platinum (1) vs 10% Rhodium (2)	S	—	—

\*Magnetic

**Table 6.3—Color Code for Thermocouple Extension Wire Per ANSI/ISA MC96.1**

Thermocouple Type		Color Code	
Wire Alloys	ANSI Symbol	+/- Individual	Jacket
*Iron vs Constantan	JX	White/Red	Black
Chromel vs *Alumel	KX	Yellow/Red	Yellow
Copper vs Constantan	TX	Blue/Red	Blue
Chromel vs Constantan	EX	Purple/Red	Purple
Platinum vs 13% Rhodium (2)	RX	Black/Red	Green
Platinum vs 10% Rhodium (2)	SX	Black/Red	Green

\*Magnetic

## 6.4 HIGH TEMPERATURE

High temperature generally refers to wire or cable with a temperature rating of 125°C (257°F) or higher. The table below lists some of the most common high-temperature wire and cable types along with their temperature rating.

**Table 6.4—High-Temperature Wire and Cable**

°C	°F	Type
538	1,000	MG (Non-UL)
450	842	MG (UL Style 5107)
250	482	TGGT (UL Styles 5196 and 5214), TKGT (UL Style 5214) TMMG, TCGT (UL Style 5288)
200	392	SRG (UL Styles 3071, 3074, 3075, 3125, 3172 and 3231), SRK, SRGK and UL Types SF-2 and SFF-2
150	302	SRG, TGS and UL Styles 3212, 3213 and 3214
125	257	UL Style 3284 and CSA CL1254

---

## 6.5 POWER

---

Below are some of the key considerations when selecting a power cable:

- System voltage
- Current loading (ampacity)
- External thermal conditions such as ambient temperature, proximity of other cables, adjacent sources of heat, thermal conductivity of soil, etc.
- Voltage drop
- Special conditions, such as the presence of corrosive agents, flexibility and flame resistance

### 6.5.1 Voltage Rating

The system voltage on which the cable is to operate determines the required cable voltage rating. Cables rated 5 kV and above are separated into two classifications: grounded systems (100 percent insulation level) and ungrounded systems (133 percent insulation level). In case of a phase-to-ground fault in a three-phase system, it is possible to operate ungrounded systems for up to one hour with one conductor at ground potential. This condition results in full line-to-line voltage stress across the insulation of each of the other two conductors. For this reason each conductor of such a circuit must have additional insulation. Cables designed for use on grounded systems take advantage of the absence of this full line-to-line voltage stress across the insulation and use thinner insulation. The direct result of such a design is lower cost, as well as reduced cable diameter.

### 6.5.2 Conductor Size

Conductor size is based principally on three considerations:

- Current-carrying capacity (ampacity)
- Short-circuit current
- Voltage drop

The current-carrying capacity of a cable is affected primarily by the permissible operating temperature of its insulation. The higher the operating temperature of the insulation, the higher the current-carrying capacity of a given conductor size. The temperature at which a particular cable will operate is affected by the ability of the surrounding material to conduct away the heat. The current-carrying capacity is materially affected by the ambient temperature as well as by the installation conditions. For example, a cable installed in a 40°C ambient temperature has an ampacity that is only about 90 percent of the ampacity in a 30°C ambient.

Running a single-conductor cable through a magnetic conduit will increase the apparent resistance of the cable and will also result in a lower current-carrying capacity due to the additional resistance and magnetic losses. Similarly, when a cable is run close to other cables, the presence of the other cables effectively increases the ambient temperature, which decreases the ability of the cable to dissipate its heat. It is apparent from the above that many conditions must be known before an accurate current-carrying capacity can be determined for a particular cable installation.

Occasionally, emergency overload conditions are also involved and may affect conductor size.

**6.5.3 Short Circuit Current**

A second consideration in selection of conductor size is that of the short-circuit current, which the cable must be able to carry in an emergency. From a thermal standpoint there is a limit to the amount of short-circuit current that a cable can handle without damage.

**Table 6.5—Thickness in Mils of Insulation for Medium-Voltage Cables**

	2,001-5,000 V	5,001-8,000 V		8,001-15,000 V		15,001-25,000 V		25,001-28,000 V		28,001-35,000 V	
Conductor Size (AWG or kcmil)	Percent Insulation Level										
	100	100	133	100	133	100	133	100	133	100	133
8	90	—	—	—	—	—	—	—	—	—	—
6-4	90	115	140	—	—	—	—	—	—	—	—
2	90	115	140	175	220	—	—	—	—	—	—
1	90	115	140	175	220	260	320	280	345	—	—
1/0-2000	90	115	140	175	220	260	320	280	345	345	420

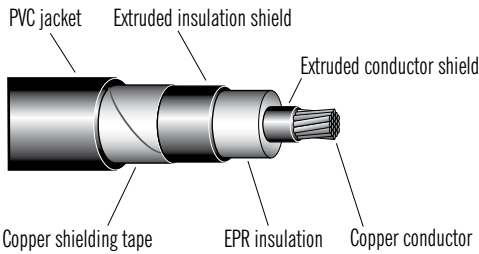

Figure 6.5—Typical Tape Shielded 15 kV Power Cable

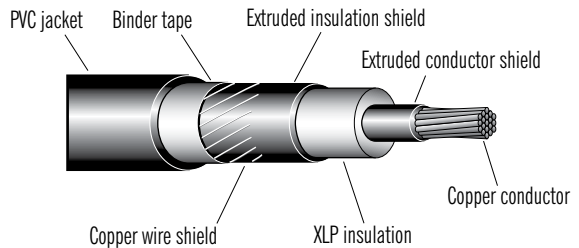

Figure 6.6—Typical Wire Shielded 15 kV Power Cable

**6.5.4 Voltage Drop Considerations**

Cable conductor size is sometimes governed by voltage drop rather than by heating. Generally, conductor size on long, low-voltage lines is governed by voltage drop; on short, high-voltage lines by heating. Due to voltage drop considerations, it might be necessary to increase conductor size, even though the current load is adequately handled by a smaller size conductor.

### 6.5.5 Special Conditions

The following are only a few of the many special conditions that may affect cable selection:

- The presence of large sources of heat (boilers, steam lines, etc.)
- The effect of magnetic materials such as pipes or structural members close to large cables carrying heavy current loads
- The presence of corrosive chemicals in the soil or other locations in which the cable is installed
- The interference that may occur in telecommunication circuits because of adjacent power cables
- Flame and radiation resistance
- Mechanical toughness
- Moisture resistance
- Overload and fault current requirements

All special conditions should be carefully investigated, and the advice of competent engineers obtained, before proceeding with an important cable installation.

## 6.6 ARMORED POWER AND CONTROL

Armored cables comprise a group of cables that are designed to withstand severe mechanical and chemical environments. For information on the various types and their applications, see [Section 5 – Armor](#).

## 6.7 ELECTRONIC CABLE

This category of wire and cable covers thousands of small gauge single-conductor wire types along with many types of multiconductor cables. These basic types come in various combinations of stranding, insulation material, conductor count, jacket material, etc. Some common types and key characteristics are described below.

### 6.7.1 Coaxial Cable

A coaxial cable consists of four basic parts:

- Inner conductor (center conductor)
- Outer conductor (shield)
- Dielectric, which separates the inner and outer conductors
- Jacket, which is the outer polymer layer protecting the parts inside

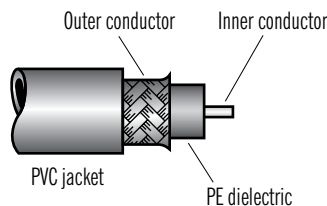

Figure 6.7—Typical Coaxial Cable

### Characteristic Impedance

The characteristic impedance of a coaxial cable is a function of its geometry and materials. Characteristic impedance is independent of length and typically ranges from 35 to 185 ohms. The most common values are 50, 75 and 93 ohms. The characteristic impedance of a cable should not be confused with the impedance of the conductors in a cable, which is dependent on length.

The most efficient transfer of energy from a source to a load occurs when all parts of the system have the same characteristic impedance. For example, a transmitter, interconnecting cable and receiver should all have the same impedance. This need for impedance matching is especially critical at higher frequencies, where the consequences of mismatches are more severe.

### VSWR

The voltage standing-wave ratio (VSWR) is a measure of the standing waves that result from reflections. It expresses the uniformity or quality of a cable's characteristic impedance. Uniformity is also measured as structural return loss (SRL).

### Velocity of Propagation

Velocity of propagation is the speed at which electromagnetic energy travels along the cable. In free space or air, electromagnetic energy travels at the speed of light, which is 186,000 miles per second. In other materials, however, the energy travels slower, depending on the dielectric constant of the material. Velocity of propagation is expressed as a percentage of the speed of light. For example, a velocity of 65 percent means that the energy travels at 120,900 miles per second — or 35 percent slower than in free space.

The dielectric (insulation) separating the two conductors determines the velocity of propagation. Although the electromagnetic energy travels in the dielectric, the current associated with the energy travels primarily on the outside of the center conductor and the inside of the outer conductor (shield). The two conductors bind the energy within the cable. Consequently, the quality of the dielectric is important to efficient, speedy transfer of energy. Speed is important to engineers who must know the transit time of signals for digital transmission.

### Voltage Rating

This is the maximum voltage the cable is designed to handle.

### Operating Temperature Range

These are the minimum and maximum temperatures at which the cable can operate.

### Coaxial Types

The following paragraphs describe four common types of coaxial cable.

- **Flexible Coax**

The most common type, flexible coax has a braided outer conductor (shield) of extremely fine wires. While the braid makes the cable flexible, it does not provide complete shielding — energy (RF signals) can leak through the shield via minute gaps in the braid. To combat this, many cables have several layers in the outer conductor. In addition, thin foils are sometimes used to supplement the braid to provide better coverage for greater shielding effectiveness. The greater the coverage, the better the shield.

- **Semirigid Coax**

Semirigid coax has a solid, tubular metallic outer conductor, similar to a pipe. This construction gives the cable a very uniform characteristic impedance (low VSWR) and excellent shielding, but at the expense of flexibility.

- **Triaxial Cable (Triax)**

This coax has two outer conductors (shields) separated by a dielectric layer. One outer conductor (shield) serves as a signal ground, while the other serves as earth ground, providing better noise immunity and shielding. One caution: Do not confuse a flexible cable having a multilayer outer shield with triaxial cable.

- **Dual Coax**

This cable contains two individual coaxial cables surrounded by a common outer jacket.

**Flexible Coax****Semirigid Coax****Triax****Dual Coax**

Figure 6.8—Common Types of Coaxial Cable

**6.7.2 Twinaxial Cable (Twinax)**

Twinax has a pair of insulated conductors encased in a common outer conductor (shield). The center conductors may be either twisted or run parallel to one another. In appearance, the cable is often similar to a shielded twisted pair, but it is held to the tighter tolerances common to fixed-impedance coaxial cable. A common use of twinax is high-speed, balanced-mode multiplexed transmission in large computer systems. Balanced mode means that the signal is carried on both conductors, which provides greater noise immunity.

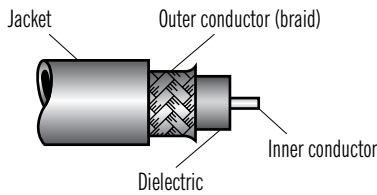
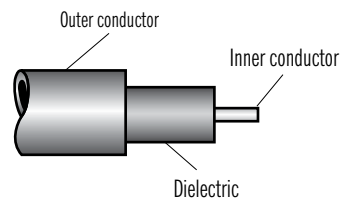
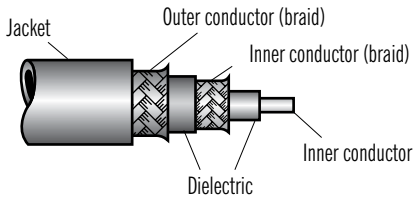
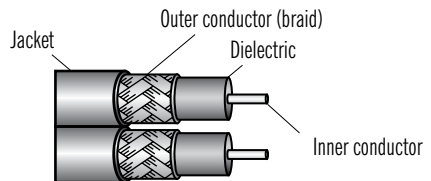
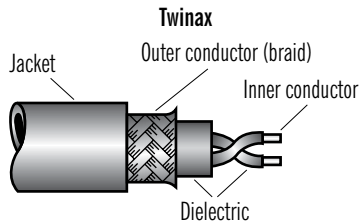

Figure 6.9—A Typical Twinaxial Cable

**6.7.3 100 ohm Twisted-Pair Cable**

100 ohm unshielded twisted pair (UTP) and shielded twisted pair (STP) are low pair-count cables (usually 4 pairs) that have been designed for use in local area networks such as Ethernet. Because of their relatively low cost these cable types are widely used and are available in several different performance categories (levels) – currently Categories 3, 5e, 6 and 6A. Insertion loss, crosstalk, impedance and other electrical parameters are specified in ANSI/TIA-568-B.2 and its related addenda. A summary of their electrical requirements are shown below.

**Table 6.6—Category 3 Performance (100 meters)**

Frequency (MHz)	Insertion Loss (dB)	NEXT (dB)	PSNEXT (dB)
0.772	2.2	43.0	43
1.0	2.6	40.3	41
4.0	5.6	32.3	32
8.0	8.5	27.8	28
10.0	9.7	26.3	26
16.0	13.1	23.2	23

Maximum propagation delay: 545 ns/100 m at 10 MHz

Maximum delay skew: 45 ns/100 m at 16 MHz

Characteristic impedance: 100 ± 15 ohms from 1 to 16 MHz

**Table 6.7—Category 5e Performance (100 meters)**

Frequency (MHz)	Insertion Loss (dB)	NEXT (dB)	PSNEXT (dB)	ELFEXT (dB)	PSELFEXT (dB)	Return Loss (dB)
1.0	2.0	65.3	62.3	63.8	60.8	20.0
4.0	4.1	56.3	53.3	51.8	48.8	23.0
8.0	5.8	51.8	48.8	45.7	42.7	24.5
10.0	6.5	50.3	47.3	43.8	40.8	25.0
16.0	8.2	47.2	44.2	39.7	36.7	25.0
20.0	9.3	45.8	42.8	37.8	34.8	25.0
25.0	10.4	44.3	41.3	35.8	32.8	24.3
31.25	11.7	42.9	39.9	33.9	30.9	23.6
62.5	17.0	38.4	35.4	27.9	24.9	21.5
100.0	22.0	35.3	32.3	23.8	20.8	20.1

Maximum propagation delay: 538 ns/100 m at 100 MHz

Maximum delay skew: 45 ns/100 m at 100 MHz



**Table 6.8—Category 6 Performance (100 meters)**

Frequency (MHz)	Insertion Loss (dB)	NEXT (dB)	PSNEXT (dB)	ELFEXT (dB)	PSELFEXT (dB)	Return Loss (dB)
0.772	1.8	76.0	74.0	70.0	67.0	19.4
1.0	2.0	74.3	72.3	67.8	64.8	20.0
4.0	3.8	65.3	63.3	55.8	52.8	23.0
8.0	5.3	60.8	58.8	49.7	46.7	24.5
10.0	6.0	59.3	57.3	47.8	44.8	25.0
16.0	7.6	56.2	54.2	43.7	40.7	25.0
20.0	8.5	54.8	52.8	41.8	38.8	25.0
25.0	9.5	53.3	51.3	39.8	36.8	24.3
31.25	10.7	51.9	49.9	37.9	34.9	23.6
62.5	15.4	47.4	45.4	31.9	28.9	21.5
100.0	19.8	44.3	42.3	27.6	24.8	20.1
200.0	29.0	39.8	37.8	21.8	18.8	18.0
250.0	32.8	38.3	36.3	19.8	16.8	17.3

Maximum propagation delay: 538 ns/100 m at 100 MHz (536 at 250 MHz)

Maximum delay skew: 45 ns/100 m at all frequencies

**Table 6.9—Category 6A Performance (100 meters)**

Frequency (MHz)	Insertion Loss (dB)	NEXT (dB)	PSNEXT (dB)	ACRF (dB)	PSACRF (dB)	Return Loss (dB)	PSANEXT (dB)	PSAACRF (dB)
1.0	2.1	74.3	72.3	67.8	64.8	20.0	67.0	67.0
4.0	3.8	65.3	63.3	55.8	52.8	23.0	67.0	66.2
8.0	5.2	60.8	58.8	49.7	46.7	24.5	67.0	60.1
10.0	5.9	59.3	57.3	47.8	44.8	25.0	67.0	58.2
16.0	7.5	56.2	54.2	43.7	40.7	25.0	67.0	54.1
20.0	8.4	54.8	52.8	41.8	38.8	25.0	67.0	52.2
25.0	9.4	53.3	51.3	39.8	36.8	24.3	67.0	50.2
31.25	10.5	51.9	49.9	37.9	34.9	23.6	67.0	48.3
62.5	15.0	47.4	45.4	31.9	28.9	21.5	67.0	42.3
100.0	19.1	44.3	42.3	27.8	24.8	20.1	67.0	38.2
150.0	23.7	41.7	39.7	24.3	21.3	18.9	67.0	34.7
200.0	27.6	39.8	37.8	21.8	18.8	18.0	64.5	32.2
250.0	31.1	38.3	36.3	19.8	16.8	17.3	62.5	30.2
300.0	34.3	37.1	35.1	18.3	15.3	16.8	61.0	28.7
350.0	37.2	36.1	34.1	16.9	13.9	16.3	59.6	27.3
400.0	40.1	35.3	33.3	15.8	12.8	15.9	58.5	26.2
450.0	42.7	34.5	32.5	14.7	11.7	15.5	57.4	25.1
500.0	45.3	33.8	31.8	13.8	10.8	15.2	56.5	24.2

Maximum propagation delay: 538 ns/100 m at 100 MHz

Maximum delay skew: 45 ns/100 m at all frequencies

### 100-ohm Unshielded Twisted Pair (UTP) vs Shielded Twisted Pair (STP)

There are two basic types of electromagnetic interference (EMI) that cable engineers worry about — EMI emissions and EMI immunity. Emissions refer to energy that is radiated by the cable that might affect the proper operation of a neighboring circuit or system. Immunity is the ability of the cable to reject outside signals that might interfere with the proper operation of the circuit or system to which the cable is attached.

Electromagnetic interference is present in all types of cabling to some degree. In local area networks (LANs), failure to properly manage EMI can have an adverse effect on the integrity of the transmitted information.

Shielded cables generally use an aluminum or copper shield to provide protection. When properly grounded (connected) to the associated electronic equipment, the shield acts as a barrier to incoming as well as outgoing EMI.

In an unshielded (UTP) cable, careful design of the cable and the associated electronic equipment results in a “balance” of the currents in the two conductors of a pair. That is, the currents in the two conductors are equal in magnitude but flowing in opposite directions. In a balanced system, there is very little radiation of EMI since the external field from one conductor is effectively canceled by the external field from the other conductor of the pair.

Generally, the more twists per foot of the cable, the better the cable is electrically balanced. For example, Category 5e cable has more twists per foot than Category 3 cable and, therefore, offers better protection from EMI problems.

### 6.7.4 IBM Cabling System

The IBM Cabling System is a structured building wiring system that is compatible with IEEE 802.5 (Token Ring) networks and equipment. Cable types consist of various combinations of shielded data grade media (DGM) and non-shielded voice grade media (VGM). Cable types include “Type 1,” which is a 2-pair DGM cable, “Type 2,” which contains two DGM pairs plus four VGM pairs and “Type 6,” which is a 2-pair DGM cable with smaller conductors (26 AWG instead of 22 AWG).

## 6.8 TELEPHONE

---

Telephone cables play a major role in modern communications. In conjunction with microwave and satellite transmission, copper and optical fiber cables provide the communication links that have become essential to society.

With the advent of optical fiber cables in the early 1980s, telephone wire and cable has generally been grouped into three broad categories:

1) fiber, 2) copper and 3) hybrid (composite) cable with both fiber and copper components under one jacket.

Telephone cable is usually classified according to its location of use. Cable used outdoors between the telephone company’s central office and the building being served is referred to as outside cable, or sometimes called black cable. Wire or cable used indoors, e.g., inside homes and commercial buildings, is referred to as premises distribution wiring or more simply as inside cable.

### 6.8.1 Outside Cables

Outside cables typically range in size from small (2 to 6 pair) constructions, which are usually referred to as “service drop” or “buried distribution” wire (the cable installed in many residential backyards), up to large 1,500 pair “exchange” cables, which are typically installed between central offices of the telephone company. Many high pair-count copper cables have been replaced by optical fiber cables.

Exchange cables, because they are often installed in underground ducts or directly buried in the earth, are designed with various combinations of polyethylene (PE) jackets and aluminum, copper or steel sheaths. The PE jacket and metal armoring isolate signal-carrying conductor pairs from moisture, mechanical damage and lightning induced voltages.

Exchange cables are manufactured in “filled” and “unfilled” (aircore) versions. With filled cables, the interstices between insulated conductors are filled with a waterproofing gel to prevent the ingress and longitudinal movement of water. Some aircore cable designs are kept dry by pressurizing the core of the cable with dry air or nitrogen. Water is the “Achilles’ heel” of outdoor telephone cable because it increases capacitance (normally 0.083  $\mu$ F per mile) between the “tip” and “ring” conductors and compromises crosstalk (pair-to-pair signal coupling) performance of the cable.

The terms tip and ring are carryovers from earlier days when each twisted pair was terminated with a 1/4-inch diameter plug at a manually operated switchboard. One conductor was attached to the tip, the other to the ring of the plug.

### 6.8.2 Indoor Cables

Inside wire and cable is usually divided into 1) station wire and 2) inside cable (sometimes called IC). Station wire is usually 2 to 4 pair, 22 or 24 AWG wire and is typically installed in residences.

While station wire is one type of inside wire, it is usually designed for both indoor and outdoor use because it often extends to the exterior of the building. True inside cable, on the other hand, is typically larger (25 to 200 pair) 22 or 24 AWG cable, which is installed exclusively indoors in larger public and commercial buildings. Station wire and inside cables are usually used in plenum, riser, and general purpose versions. The plenum version is a highly flame retardant construction that is capable of passing the Steiner Tunnel Flame Test (NFPA-262).

Article 800 of the National Electrical Code (NEC) requires that telephone wire and cable be plenum rated when installed indoors in plenums (air handling spaces) without conduit, i.e., it must carry the marking CMP (CM for communication and P for plenum). When installed in vertical risers in multistory buildings, a riser rating, i.e., Type CMR, is required. General purpose communication cables must be labeled Type CM. Cables installed in one- and two-family dwellings must be identified as Type CMX.

### 6.8.3 Insulation and Jacket Materials

Two thermoplastic polymers are generally used to insulate the conductors of outdoor telephone wire and cable: polypropylene (PP) or polyethylene (PE). These polymers are used primarily because of their low dielectric constant, high dielectric strength (to withstand lightning induced overvoltages), excellent moisture resistance, mechanical toughness, extrudability in thin walls and low cost. Indoor dielectrics include PP and PE but, in addition, include FEP (fluorinated ethylene-propylene or Teflon), ECTFE (ethylene-chlorotrifluoroethylene or Halar) and PVC (polyvinyl chloride). FEP and ECTFE are used in plenum cables to provide the necessary flame retardancy and are extruded on the wire in either solid or foamed (expanded) versions.

The most important telephone wire and cable electrical characteristics and their usual units of measurement include capacitance (microfarads per mile), conductor resistance (ohm per loop-mile), crosstalk (decibel isolation between pairs) and attenuation (decibels per mile). When used for high-speed digital applications, characteristic impedance (ohm) and structural return loss (decibels) also become important.

The mechanical and chemical characteristics of telephone cable insulation are as important as the electrical characteristics. Several important mechanical and chemical characteristics include compression cut resistance, low-temperature brittleness, resistance to the base oils used in filling gels, adequate tensile and elongation properties, and acceptable long-term aging characteristics.

## 6.9 MILITARY

The U.S. military has developed extensive specifications for many wire and cable types used in military applications. This includes hook-up and lead wire, airframe wire, control cable and coax. A MIL-Spec wire or cable must meet rigorous performance requirements. Tests that prove the wire or cable meets the specified requirements must be conducted by the manufacturer and must be carefully documented.

Following is a partial list of military wire and cable types.

Type	Description
MIL-C-5756	Cable and wire, portable power, rubber insulated (replaced by SAE-AS5756)
MIL-C-7078	Cable, aerospace vehicle (replaced by NEMA WC27500)
MIL-C-13294	Field wire (replaced by MIL-DTL-49104—inactive)
MIL-DTL-915	Shipboard cable (inactive for new design except outboard types)
MIL-DTL-3432	Power and special purpose cables used for ground support systems (“CO” types), 300 and 600 V
MIL-DTL-8777	Aircraft wire, silicone insulated, 600 V, 200°C (inactive for new design)
MIL-DTL-13486	Cable, special purpose, low tension, single and multiconductor, shielded and unshielded
MIL-DTL-16878	General purpose hook-up and lead wire
MIL-DTL-24640	Shipboard cable, lightweight
MIL-DTL-24643	Shipboard cable, low smoke
MIL-DTL-25038	Aircraft wire, inorganic fibrous/Teflon insulation, high temperature and fire resistant, engine zone wire
MIL-DTL-23053	Tubing, heat shrink (replaced by SAE-AMS-DTL-23053)
MIL-DTL-27072	Cable, power and special purpose, multiconductor and single shielded
MIL-DTL-27500	Aerospace and other general application wire (replaced by NEMA WC27500)
MIL-DTL-49055	Cable, power, flat, unshielded
MIL-DTL-55021	Cable, shielded singles, twisted pairs and triples, internal hook-up
MIL-I-22129	Tubing, PTFE, nonshrink
MIL-W-76	General purpose hook-up wire
MIL-W-5845	Thermocouple wire, iron and Constantan (cancelled with no replacement)
MIL-W-5846	Thermocouple wire, chromel and alumel
MIL-W-81822	Solderless wrap (wire wrap), insulated and uninsulated (replaced by SAE-AS81822)
MIL-W-47206	Cable, single conductor, twisted pairs; and multiconductor, high temperature (replaced by MIL-DTL-27500)

## 6.10 SHIPBOARD CABLES (MIL-DTL-24643, MIL-DTL-24640 AND MIL-DTL-915)

Due to concern about flammability, smoke and toxicity, the U.S. Navy introduced the MIL-DTL-24643 cable specification. Generally, this document provides low-smoke, fire-retardant cables that are approximately equivalent in size, weight and electricals to many of the older MIL-DTL-915 constructions.

In consideration of circuit density, weight and size, the U.S. Navy produced the MIL-DTL-24640 cable document. The cables covered by this specification are also low-smoke, fire-retardant constructions, but they are significantly lighter in weight and smaller in diameter. MIL-DTL-24640 cables are used to interconnect systems where weight and space savings are critical; however, they are not direct replacements. Because the overall diameters have been reduced and electrical characteristics may have been changed, they should not be used to replace existing MIL-DTL-915 or MIL-DTL-24643 constructions unless a comprehensive electrical and physical system evaluation or redesign has been completed.

For many years, most of the shipboard power and lighting cables for fixed installation had silicone-glass insulation, polyvinyl chloride jacket, and aluminum armor and were of watertight construction. It was determined that cables with all of these features were not necessary for many applications, especially for applications within watertight compartments and noncritical areas above the watertightness level. Therefore, for applications within watertight compartments and noncritical areas, a new family of non-watertight lower cost cables was designed. This family of cables is electrically and dimensionally interchangeable with silicone-glass insulated cables of equivalent sizes and is covered by Military Specification MIL-DTL-915.

## 6.11 OPTICAL FIBER CABLES

In all types of optical fiber cables, the individual optical fibers are the signal transmission media that act as individual optical wave guides. The fibers consist of a central transparent core region that propagates the optical radiation and an outer cladding layer that completes the guiding structure. The core and the cladding are typically made of pure silica glass, though other materials can be used. To achieve high signal bandwidth capabilities, the core region sometimes has a varying (or graded) refractive index.

### 6.11.1 Fiber Types

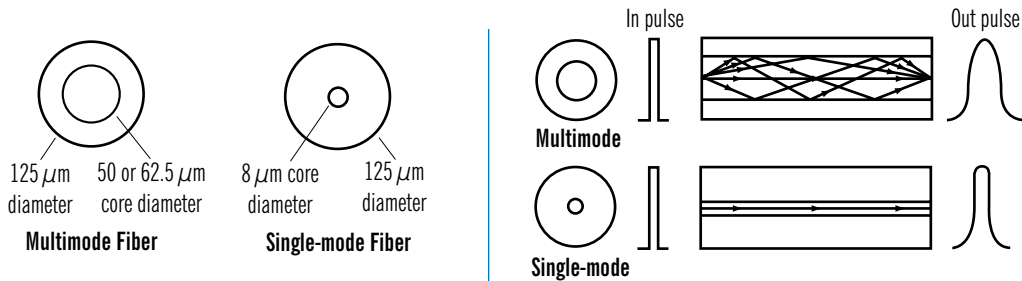

Figure 6.10—Optical Fiber Types

There are two basic fiber types – single-mode and multimode. Single-mode has a core diameter of 8 to 10 microns and is normally used for long distance requirements (e.g., interstate) and high-bandwidth (information carrying capacity) applications. Multimode, on the other hand, has a core diameter of 50 or 62.5 microns and is usually used intrabuilding.

Laser-optimized fibers are a fairly recent development in which 50-micron multimode fibers are optimized for 850 nm VCSEL (vertical cavity surface emitting laser) sources and can provide significantly increased bandwidth performance when compared with standard multimode fiber types. The added bandwidth of laser-optimized 50-micron fiber allows for distance support up to 550 meters for 10 Gigabit Ethernet networks as well as providing a lower overall system cost when compared with single-mode systems utilizing higher cost 1300 or 1550 laser sources. Laser-optimized fiber is referred to as “OM3” fiber in ISO/IEC-11801. OM3 fibers are also referenced by other industry standards, such as the ANSI/TIA-568 wiring standards and Institute of Electrical and Electronics Engineers (IEEE). OM1 and OM2 designations are specified for standard 62.5 and 50 micron multimode fibers, respectively.

### 6.11.2 Fiber Selection

The three major fiber parameters used in selecting the proper fiber for an application are bandwidth, attenuation and core diameter.

#### Bandwidth

The bandwidth at a specified wavelength represents the highest sinusoidal light modulation frequency that can be transmitted through a length of fiber with an optical signal power loss equal to 50 percent (-3 dB) of the zero modulation frequency component. The bandwidth is expressed in megahertz over a kilometer length (MHz-km).

#### Attenuation

The optical attenuation denotes the amount of optical power lost due to absorption and scattering of optical radiation at a specified wavelength in a length of fiber. It is expressed as an attenuation in decibels of optical power per kilometer (dB/km).

The attenuation is determined by launching a narrow spectral band of light into the full length of fiber and measuring the transmitted intensity. This measure is then repeated for the first 1.5 to 2.5 meters of the same fiber cable without disturbing the input end of the fiber. The dB/km attenuation is then calculated and normalized to 1 km.

#### Core Diameter

The fiber core is the central region of an optical fiber whose refractive index is higher than that of the fiber cladding. Various core diameters are available to permit the most efficient coupling of light from commercially available light sources, such as LEDs or laser diodes.

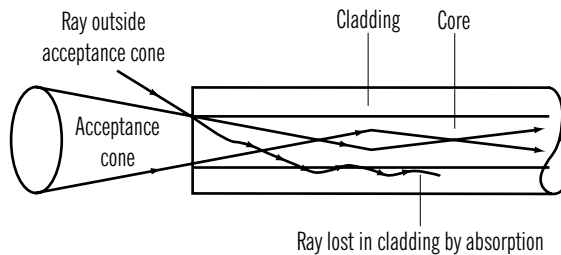

Figure 6.11—Optical Fiber Attenuation

### 6.11.3 Optical Fiber Cable Selection

Another important consideration when specifying optical fiber cable is the cable construction. Proper selection depends on the environment in which the cable will be installed. One of two different types of cable construction are generally employed to contain and protect the optical fibers.

#### Loose Buffer

The first is a loose buffer tube construction where the fiber is contained in a water-blocked polymer tube that has an inner diameter considerably larger than the fiber itself. This provides a high level of isolation for the fiber from external mechanical forces that might be present on the cable. For multifiber cables, a number of these tubes, each containing one or more fibers, are combined with the necessary longitudinal strength member. Loose buffer cables are typically used in outdoor applications and can accommodate the changes in external conditions (e.g., contraction in cold weather and elongation in warm weather).

### Tight Buffer

The second cable construction is a tight buffer tube design. Here, a thick buffer coating is placed directly on the fiber.

Both constructions have inherent advantages. The loose buffer tube construction offers lower cable attenuation from a given fiber, plus a high level of isolation from external forces. This means more stable transmission characteristics under continuous mechanical stress. The tight buffer construction permits smaller, lighter weight designs and generally yields a more flexible cable. A comparison of these two cable constructions is shown below.

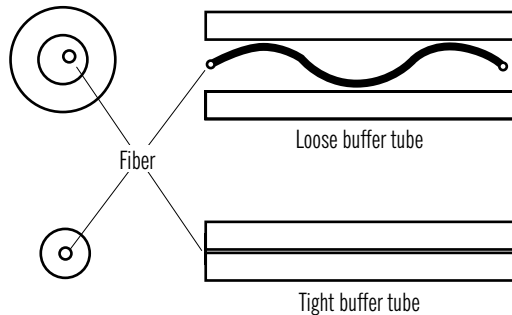

Figure 6.12—Optical Fiber Cable Designs

Table 6.10—A Comparison of Loose Tube and Tight Buffer Optical Fiber Cable

Cable Parameter	Cable Construction	
	Loose Tube	Tight Buffer
Bend radius	Larger	Smaller
Diameter	Larger	Smaller
Tensile strength, installation	Higher	Lower
Impact resistance	Higher	Lower
Crush resistance	Higher	Lower
Attenuation change at low temperatures	Lower	Higher

### Strength Members

Once the optical fiber is surrounded with a buffer, either loose or tight, strength members are added to the cable structure to keep the fibers free from stress and to minimize elongation and contraction. Such strength members provide tensile load properties similar to electronic cables and, in some cases, are used as temperature stabilization elements.

### Jacket

As with conventional metallic cables, the jacket protects the core from the external environment. With optical fibers, however, the selection of materials is influenced by the fact that the thermal coefficient of expansion of glass is significantly lower than that of the metal or plastic used in the cable structure.

### Installation

Normal cable loads sustained during installation or environmental movements first stress the strength members without transferring the stress to the optical fibers. If the load is increased, the fiber may ultimately be placed in a tensile stress state. This level of stress may cause microbending losses that result in attenuation increase and possibly fatigue effects.

### 6.12 TRAY CABLES

Tray cables are a special class of cables designed to meet stringent flame test requirements. A tray cable rating is given to a cable if it can meet the UL or CSA Standard for the rating. To obtain the rating, a cable must pass the 70,000 BTU, UL 1685 Vertical Tray Flame test or the Vertical Flame Test described in CSA C22.2 No. 0.3 (See Section 11.2 Fire Safety Tests for additional information).

In effect, a cable does not have a tray cable rating unless it is so marked, for example “for CT use” or “Type TC.” Electrical inspectors will usually reject a cable even if it is capable of passing the tray cable fire test unless it is clearly marked on the cable as being a tray-rated cable.

A summary of applicable UL Standards, listings and markings is shown in Table 6.11. Note that, in some cases, the tray rating is an optional marking and is not an inherent part of the listing. Other UL and CSA Types that can be installed in tray in accordance with the NEC include CL2, CL2R, CL2P, CL3, CL3R, CL3P, OFN, OFNR and OFNP.

Table 6.11—Tray Cable Listings and Markings for Cable Allowed in Tray

Standard	UL Listings (Types)	Optional Markings
UL 4	AC	For CT use Low Smoke
UL 13	PLTC	Direct burial ER (Exposed Run) Wet locations
UL 44	XHHW-2 RHW-2, RHH, RH SIS, SA	For CT use (1/0 and larger) Sunlight resistant Oil resistant Pump cable (LS) Limited smoke
UL 444	CM, CMR, CMP, CMG	(LS) Limited smoke
UL 1072	MV	For CT use Direct burial Sunlight resistant Oil resistant
UL 1277	TC	Direct burial Sunlight resistant Oil resistant ER (Exposed Run) LS (Limited Smoke)
UL 1424	FPL, FPLR, FPLP	Direct burial Sunlight resistant CI (Circuit Integrity) Limited combustible Wet location
UL 1425	NPLF, NPLFR, NPLFP	Direct burial Sunlight resistant CI (Circuit Integrity) Limited combustible Wet location
UL 1569	MC	For CT USC Sunlight resistant Direct burial (LS) Limited smoke
UL 2250	ITC	Direct burial Wet location ER (Exposed Run)



# 7. ELECTRICAL CHARACTERISTICS

7.1	DC Resistance of Plated Copper Conductors	86
7.2	DC and AC Resistance of Copper Conductors	89
7.3	DC and AC Resistance of Aluminum Conductors	91
7.4	Reactance and Impedance at 60 Hz	92
7.5	AC/DC Resistance Ratio at 60 Hz	93
7.6	Temperature Correction Factors for Resistance	94
7.7	Voltage Drop	95
7.8	Maximum Conductor Short Circuit Current	96
7.9	Maximum Shield Short Circuit Current	99
7.10	Resistance and Ampacity at 400 and 800 Hz	100
7.11	Current Ratings for Electronic Cables	101
7.12	Ampacity of Power Cables	102
7.13	Basic Impulse Level (BIL) Ratings	102

## 7. Electrical Characteristics

For a wire or cable to perform its intended function reliably, safely and efficiently, the wire or cable must be selected so that its many electrical, physical, chemical and thermal properties match those of the application.

The following sections provide information on some of the most frequently requested electrical parameters.

### 7.1 DC RESISTANCE OF PLATED COPPER CONDUCTORS

Table 7.1—DC Resistance of Plated Copper Conductors

Wire Size (AWG/kcmil)	No. of Wires/Size (AWG or in.)	Strand Class	Nominal Area (cmils)	Nominal DC Resistance ohms/1,000 ft. at 20°C (68°F)		
				Silver Plated	Nickel Plated	Tin Plated
777	1,952/24	AAR	788,728	—	—	0.0139
750	703/0.0327	H	751,711	—	—	0.0146
750	1,862/24	I	752,267	—	—	0.0146
750	7,448/30	K	744,800	—	—	0.0148
700	703/0.0316	H	701,988	—	—	0.0157
700	1,729/24	I	698,533	—	—	0.0158
700	6,916/30	K	691,600	—	—	0.0165
650	703/0.0304	H	649,684	—	—	0.0169
650	1,596/24	I	644,800	—	—	0.0171
650	6,517/30	K	651,700	—	—	0.0169
646	1,647/24	AAR	665,404	—	—	0.0165
600	703/0.0292	H	599,406	—	—	0.0183
600	1,470/24	I	593,895	—	—	0.0185
600	5,985/30	K	598,500	—	—	0.0184
550	703/0.028	H	551,152	—	—	0.0200
550	1,372/24	I	554,302	—	—	0.0200
550	5,453/30	K	545,300	—	—	0.0200
535	1,332/24	AAR	538,141	—	—	0.0204
500	427/0.0342	H	449,436	—	—	0.0220
500	1,125/24	I	494,912	—	—	0.0222
500	5,054/30	K	505,400	—	—	0.0218
450	427/0.0325	H	451,019	—	—	0.0244
450	1,127/24	I	455,319	—	—	0.0241
450	4,522/30	K	452,200	—	—	0.0243
444	1,110/24	AAR	448,451	—	—	0.025
400	427/0.0306	H	399,826	—	—	0.028
400	980/24	I	395,930	—	—	0.028
400	3,990/30	K	399,000	—	—	0.028
373	925/24	AAR	373,709	—	—	0.029

Continued >>

Table 7.1—DC Resistance of Plated Copper Conductors (Continued)

Wire Size (AWG/kcmil)	No. of Wires/Size (AWG or in.)	Strand Class	Nominal Area (cmils)	Nominal DC Resistance ohms/1,000 ft. at 20°C (68°F)		
				Silver Plated	Nickel Plated	Tin Plated
350	427/0.0286	H	349,269	—	—	0.031
350	882/24	I	356,337	—	—	0.031
350	3,458/30	K	345,800	—	—	0.032
313	777/24	AAR	313,916	—	—	0.035
300	427/0.0265	H	299,861	—	—	0.037
300	735/24	I	296,947	—	—	0.037
300	2,989/30	K	298,900	—	—	0.037
262	646/24	AAR	260,990	—	—	0.042
250	427/0.0242	H	250,068	—	—	0.043
250	637/24	I	257,354	—	—	0.043
250	2,499/30	K	249,900	—	—	0.044
4/0	2,109/30	K	210,900	0.052	0.053	0.052
4/0	427/0.0223	H	212,343	0.052	0.053	0.052
3/0	1,665/30	K	166,500	0.066	0.067	0.069
3/0	427/0.0198	H	167,401	0.066	0.067	0.066
2/0	1,330/30	K	133,000	0.083	0.084	0.088
2/0	427/0.0177	H	133,775	0.083	0.084	0.082
1/0	1,045/30	K	104,500	0.105	0.107	0.116
1/0	259/0.0202	H	105,682	0.105	0.107	0.103
1	817/30	K	81,700	0.134	0.137	0.144
1	259/0.018	H	83,916	0.134	0.137	0.129
2	665/30	K	66,500	0.165	0.168	0.177
2	259/0.016	H	66,304	0.165	0.168	0.164
2	133/0.0223	H	66,140	0.165	0.168	0.164
3	133/0.0199	H	52,669	0.165	0.168	0.205
4	133/25	H	42,615	0.249	0.259	0.264
5	133/0.0158	H	33,202	0.249	0.259	0.325
6	133/27	H	26,818	0.393	0.409	0.417
8	19/0.0295	C	16,535	0.628	0.689	0.640
8	37/0.0211	D	16,473	0.630	0.692	0.655
8	133/29	H	16,983	0.616	0.642	0.654
10	7/0.0385	B	10,376	1.00	1.10	1.02
10	19/0.0234	C	10,404	1.00	1.10	1.03
10	37/26	D	9,354	1.13	1.18	1.20
12	7/0.0305	B	6,512	1.59	1.75	1.65

Continued &gt;&gt;

## 7. Electrical Characteristics

**Table 7.1—DC Resistance of Plated Copper Conductors (Continued)**

Wire Size (AWG/kcmil)	No. of Wires/Size (AWG or in.)	Strand Class	Nominal Area (cmils)	Nominal DC Resistance ohms/1,000 ft. at 20°C (68°F)		
				Silver Plated	Nickel Plated	Tin Plated
12	19/25	C	6,088	1.71	1.78	1.81
12	19/0.0185	C	6,503	1.60	1.75	1.70
12	37/28	D	5,874	1.80	1.87	1.91
12	65/30	K	6,500	1.80	1.87	1.61
14	7/0.0242	B	4,099	2.53	2.69	2.63
14	19/27	C	3,831	2.70	2.81	2.86
14	19/0.0147	C	4,105	2.62	2.65	2.78
14	37/0.0105	D	4,079	2.62	2.65	2.59
14	41/30	K	4,100	2.62	2.65	2.58
16	7/0.0192	B	2,580	4.02	4.28	4.27
16	19/29	C	2,426	4.23	4.41	4.49
16	19/0.0117	C	2,600	4.14	4.20	4.39
16	26/30	K	2,600	4.14	4.20	4.07
18	7/0.0152	B	1,617	6.58	6.67	6.99
18	7/26	B	1,769	5.86	6.10	6.22
18	16/30	K	1,600	5.86	6.10	6.61
18	19/30	C	1,900	5.38	5.60	5.77
18	19/0.0092	C	1,608	6.69	6.82	7.18
20	7/.28	B	1,111	9.27	9.65	9.84
20	10/30	K	1,000	—	—	10.58
20	19/32	C	1,216	8.53	9.07	9.15
22	7/30	B	700	14.60	15.20	15.60
22	19/34	C	754	13.70	14.60	14.70
24	7/34	B	448	23.10	24.60	24.80
24	19/36	C	475	21.50	22.90	23.10
25	7/0.0067	B	314	33.00	34.80	36.40
26	7/34	B	277	37.10	39.50	39.80
26	19/38	C	304	33.30	36.60	35.70
28	7/36	B	175	58.40	62.10	66.50
28	19/40	C	182	54.60	60.00	58.60
30	7/38	B	112	90.30	99.20	96.20
30	19/42	C	118	82.70	94.00	88.80
32	7/40	B	67	148.0	163.0	159.0
34	7/42	B	43	225.0	256.0	241.5
36	7/44	B	28	244.0	391.0	369.2

Note: AAR — American Association of Railroads  
Strand Classes B, C, D, H, I and K per ASTM

## 7.2 DC AND AC RESISTANCE OF COPPER CONDUCTORS

Table 7.2—DC and AC Resistance of Copper Conductors, Nominal ohms Per 1,000 ft.

Size	20°C Conductor Temperature		60°C Conductor Temperature		75°C Conductor Temperature			90°C Conductor Temperature		
	DC	DC	60 Hz AC		DC	60 Hz AC		DC	60 Hz AC	
			*Single Cond.	†Multi- Cond.		*Single Cond.	†Multi- Cond.		*Single Cond.	†Multi- Cond.
40	1,080.0	1,250.0	—	—	1,314.0	—	—	1,378.0	—	—
38	648.6	750.7	—	—	789.1	—	—	827.3	—	—
36	414.8	480.1	—	—	504.6	—	—	529.1	—	—
34	260.9	302.0	—	—	317.4	—	—	332.8	—	—
32	164.1	189.9	—	—	199.6	—	—	209.3	—	—
30	103.2	119.4	—	—	125.5	—	—	131.6	—	—
28	64.9	75.1	—	—	79.0	—	—	82.8	—	—
26	40.8	47.2	—	—	49.7	—	—	52.1	—	—
24	26.1	30.2	—	—	31.8	—	—	33.3	—	—
22	16.4	19.0	—	—	20.0	—	—	20.9	—	—
20	10.3	11.9	—	—	12.5	—	—	13.1	—	—
18	6.54	7.57	—	—	7.96	—	—	8.34	—	—
16	4.1	4.75	—	—	4.99	—	—	5.23	—	—
14	2.57	2.98	2.98	2.98	3.14	3.14	3.14	3.29	3.29	3.29
12	1.62	1.88	1.88	1.88	1.97	1.97	1.97	2.07	2.07	2.07
10	1.17	1.18	1.18	1.18	1.24	1.24	1.24	1.31	1.31	1.31
8	0.638	0.744	0.744	0.744	0.783	0.783	0.783	0.822	0.822	0.822
6	0.403	0.466	0.466	0.466	0.491	0.491	0.491	0.515	0.515	0.515
4	0.253	0.295	0.295	0.295	0.310	0.310	0.31	0.325	0.325	0.325
2	0.159	0.184	0.184	0.185	0.195	0.194	0.196	0.203	0.203	0.205
1	0.126	0.147	0.147	0.148	0.154	0.154	0.155	0.162	0.162	0.163
1/0	0.1	0.116	0.116	0.118	0.122	0.122	0.124	0.128	0.128	0.13
2/0	0.0794	0.0923	0.0923	0.0950	0.0971	0.0971	0.1	0.102	0.102	0.105
3/0	0.0629	0.073	0.073	0.0759	0.0769	0.0769	0.0799	0.0807	0.0807	0.0839
4/0	0.05	0.0579	0.0579	0.0608	0.061	0.061	0.064	0.0639	0.0639	0.0671

Note: 40 AWG through 26 AWG values are for solid conductors, all others are for ASTM Class B stranded conductors.

\*One single conductor in air, buried or in nonmetallic conduit.

†Multiconductor cable or two or three single conductors in one metallic conduit.

Continued >>

## 7. Electrical Characteristics

**Table 7.2—DC and AC Resistance of Copper Conductors, Nominal ohms Per 1,000 ft. (Continued)**

Size	20°C Conductor Temperature		60°C Conductor Temperature		75°C Conductor Temperature			90°C Conductor Temperature		
	DC	DC	60 Hz AC		DC	60 Hz AC		DC	60 Hz AC	
			*Single Cond.	†Multi-Cond.		*Single Cond.	†Multi-Cond.		*Single Cond.	†Multi-Cond.
250	0.0423	0.049	0.0492	0.0519	0.0516	0.0518	0.0547	0.0541	0.0543	0.0573
300	0.0353	0.0409	0.0411	0.0437	0.0431	0.0433	0.0461	0.0452	0.0454	0.0483
350	0.0302	0.035	0.0353	0.0378	0.0369	0.0372	0.0398	0.0387	0.0390	0.0418
400	0.0264	0.0307	0.031	0.0338	0.0323	0.0326	0.0355	0.0339	0.0342	0.0373
500	0.0212	0.0246	0.025	0.0278	0.0258	0.0262	0.0291	0.0271	0.0275	0.0306
600	0.0177	0.0205	0.021	0.0238	0.0215	0.022	0.0249	0.0226	0.0231	0.0262
700	0.0151	0.0175	0.0181	0.0208	0.0184	0.019	0.0219	0.0193	0.0199	0.0229
750	0.0141	0.0164	0.0170	0.0198	0.0172	0.0178	0.0208	0.0181	0.0188	0.0219
1,000	0.0106	0.0123	0.0131	0.016	0.0129	0.0137	0.0167	0.0135	0.0144	0.0175
1,250	0.00847	0.00982	0.0108	0.0138	0.0103	0.0113	0.0145	0.0108	0.0119	0.0152
1,500	0.00705	0.00818	0.00934	0.0125	0.00861	0.00983	0.0132	0.00904	0.01030	0.0138
1,750	0.00604	0.00701	0.0083	0.0117	0.00738	0.00874	0.0123	0.00774	0.00917	0.0129
2,000	0.00529	0.00613	0.00755	0.0111	0.00645	0.00795	0.0117	0.00677	0.00835	0.0123
2,500	0.00428	0.00496	—	—	0.00521	—	—	0.00546	—	—
3,000	0.00356	0.00412	—	—	0.00433	—	—	0.00454	—	—
5,000	0.00218	0.00252	—	—	0.00265	—	—	0.00278	—	—

Note: 40 AWG through 26 AWG values are for solid conductors, all others are for ASTM Class B stranded conductors.

\*One single conductor in air, buried or in nonmetallic conduit.

†Multiconductor cable or two or three single conductors in one metallic conduit.

**Table 7.3—Temperature Correction Factors for Copper DC Resistance**

Temperature (°C)	Multiplying Factors for Correction To:	
	20°C	25°C
60	0.864	0.881
75	0.822	0.838
90	0.784	0.800

Example: The DC resistance of a 500 kcmil copper conductor at 60°C is 0.0246 ohms per 1,000 ft. The resistance at 25°C would be  $0.0246 \times 0.881 = 0.0217$  ohms per 1,000 ft.

### 7.3 DC AND AC RESISTANCE OF ALUMINUM CONDUCTORS

Table 7.4—DC and AC Resistance of Class B Aluminum Conductors, ohms Per 1,000 ft.

Size	60°C Conductor Temperature			75°C Conductor Temperature			90°C Conductor Temperature		
	DC	60 Hz AC		DC	60 Hz AC		DC	60 Hz AC	
		*Single Cond.	†Multi- Cond.		*Single Cond.	†Multi- Cond.		*Single Cond.	†Multi- Cond.
12	3.08	3.08	3.08	3.24	3.24	3.24	3.40	3.40	3.40
10	1.93	1.93	1.93	2.03	2.03	2.03	2.13	2.13	2.13
8	1.21	1.21	1.21	1.28	1.28	1.28	1.34	1.34	1.34
6	0.765	0.765	0.765	0.808	0.808	0.808	0.848	0.848	0.848
4	0.483	0.483	0.483	0.507	0.507	0.507	0.533	0.533	0.533
3	0.382	0.382	0.382	0.402	0.402	0.402	0.422	0.422	0.422
2	0.303	0.303	0.303	0.319	0.319	0.319	0.335	0.335	0.335
1	0.240	0.240	0.240	0.253	0.253	0.253	0.266	0.266	0.266
1/0	0.191	0.191	0.191	0.201	0.201	0.201	0.211	0.211	0.211
2/0	0.151	0.151	0.151	0.159	0.159	0.159	0.167	0.167	0.167
3/0	0.119	0.119	0.120	0.126	0.126	0.127	0.132	0.132	0.133
4/0	0.0953	0.0954	0.0963	0.101	0.101	0.102	0.106	0.106	0.107
250	0.0806	0.0808	0.0822	0.0848	0.0850	0.0865	0.0890	0.0892	0.0908
300	0.0672	0.0674	0.0686	0.0706	0.0708	0.0720	0.0741	0.0744	0.0756
350	0.0575	0.0578	0.0593	0.0605	0.0608	0.0623	0.0635	0.0638	0.0654
400	0.0504	0.0507	0.0525	0.0500	0.0533	0.0552	0.0557	0.0560	0.0580
500	0.0403	0.0406	0.0428	0.0424	0.0427	0.0450	0.0445	0.0448	0.0472
600	0.0336	0.0340	0.0370	0.0353	0.0357	0.0381	0.0370	0.0374	0.0400
700	0.0288	0.0292	0.0320	0.0303	0.0307	0.0337	0.0318	0.0322	0.0353
750	0.0269	0.0273	0.0302	0.0283	0.0288	0.0317	0.0297	0.0302	0.0333
1,000	0.0201	0.0207	0.0239	0.0212	0.0218	0.0253	0.0222	0.0228	0.0265
1,250	0.0162	0.0176	0.0215	0.0170	0.0177	0.0216	0.0179	0.0186	0.0228
1,500	0.0135	0.0143	0.0184	0.0142	0.0150	0.0193	0.0149	0.0158	0.0203
1,750	0.0115	0.0124	0.0168	0.0121	0.0131	0.0177	0.0127	0.0137	0.0186
2,000	0.0101	0.0111	0.0158	0.0106	0.0117	0.0165	0.0111	0.0122	0.0173

\*One single conductor in air, buried or in nonmetallic conduit.

†Multiconductor cable or two or three single conductors in one metallic conduit.

## 7. Electrical Characteristics

**Table 7.5—Temperature Correction Factors for Aluminum DC Resistance**

Temperature (°C)	Multiplying Factors for Correction To:	
	20°C	25°C
60	0.861	0.878
75	0.818	0.835
90	0.780	0.796

Example: The DC resistance of a 500 kcm aluminum conductor at 60°C is 0.0403 ohms per 1,000 ft. The resistance at 25°C would be  $0.0403 \times 0.878 = 0.0354$  ohms per 1,000 ft.

## 7.4 REACTANCE AND IMPEDANCE AT 60 HZ

**Table 7.6—Reactance and Impedance at 60 Hz for Single Copper Conductor Cables Installed in Air, Buried or in Separate Nonmetallic Conduits**

Conductor Size (AWG/kcmil)	Approximate ohms per 1,000 ft. per Conductor at 25°C (77°F)							
	Distance Between Centers of Conductors							
	2 in.		4 in.		6 in.		8 in.	
	Reactance	Impedance	Reactance	Impedance	Reactance	Impedance	Reactance	Impedance
8	0.0816	0.659	0.0976	0.661	0.1070	0.662	0.1135	0.664
6	0.0764	0.417	0.0922	0.420	0.1016	0.422	0.1082	0.424
4	0.0710	0.255	0.0868	0.261	0.0962	0.264	0.1025	0.267
3	0.0682	0.216	0.0842	0.221	0.0934	0.225	0.1000	0.228
2	0.0656	0.175	0.0815	0.181	0.0908	0.186	0.0974	0.189
1	0.0627	0.143	0.0787	0.151	0.0880	0.156	0.0945	0.160
1/0	0.0600	0.118	0.0760	0.127	0.0853	0.133	0.0918	0.137
2/0	0.0598	0.0993	0.0732	0.109	0.0826	0.116	0.0892	0.121
3/0	0.0573	0.0884	0.0706	0.0954	0.0799	0.103	0.0866	0.108
4/0	0.0520	0.0728	0.0680	0.0850	0.0773	0.0926	0.0840	0.0982
250	0.0500	0.0661	0.0660	0.0789	0.0753	0.0869	0.0819	0.0926
300	0.0481	0.0602	0.0640	0.0734	0.0732	0.0816	0.0798	0.0876
350	0.0462	0.0557	0.0622	0.0695	0.0715	0.0779	0.0780	0.0840
400	0.0445	0.0522	0.0606	0.0664	0.0700	0.0750	0.0766	0.0814
500	0.0422	0.0476	0.0581	0.0621	0.0674	0.0709	0.0740	0.0772
600	0.0400	0.0441	0.0559	0.0588	0.0652	0.0678	0.0718	0.0741
700	0.0380	0.0412	0.0539	0.0561	0.0633	0.0652	0.0700	0.0718
750	0.0376	0.0404	0.0534	0.0554	0.0628	0.0645	0.0694	0.0710
800	0.0370	0.0396	0.0527	0.0546	0.0621	0.0636	0.0687	0.0701
900	0.0354	0.0376	0.0512	0.0527	0.0606	0.0619	0.0673	0.0685
1,000	0.0342	0.0360	0.0500	0.0512	0.0594	0.0605	0.0660	0.0670
1,250	0.0314	0.0328	0.0472	0.0481	0.0566	0.0574	0.0632	0.0639
1,500	0.0296	0.0307	0.0453	0.0460	0.0548	0.0554	0.0614	0.0619
1,750	0.0276	0.0285	0.0434	0.0440	0.0527	0.0532	0.0593	0.0597
2,000	0.0264	0.0272	0.0422	0.0427	0.0514	0.0518	0.0582	0.0585

For equations that can be used to calculate inductive reactance for other conductor spacings, see [Section 18.10](#).



## 7.5 AC/DC RESISTANCE RATIO AT 60 HZ

**Table 7.7—AC/DC Resistance Ratio at 60 Hz**

To determine effective 60 Hz AC resistance, multiply DC resistance values corrected for proper temperature by the AC/DC resistance ratio given below.

Conductor Size (AWG/kcmils)	Single Copper Conductors in Air, or in Individual Nonmetallic Conduits	Multiple Copper Conductor Cable or Two or Three Single-Conductor Cables in Same Metallic Conduit
Up to 3	1.00	1.00
2 and 1	1.00	1.01
1/0	1.00	1.02
2/0	1.00	1.03
3/0	1.00	1.04
4/0	1.00	1.05
250	1.005	1.06
300	1.006	1.07
350	1.009	1.08
400	1.011	1.10
500	1.018	1.13
600	1.025	1.16
700	1.034	1.19
750	1.039	1.21
800	1.044	—
1,000	1.067	—
1,250	1.102	—
1,500	1.142	—
1,750	1.185	—
2,000	1.233	—

Source: Underground Systems Reference Book, Edison Electric Institute, 1957.

The single-conductor column in the table above covers single-conductor nonshielded cable having spacing of six inches or more including all conditions of use except when two or more cables are pulled into the same metallic or nonmetallic conduit.

The multiple-conductor column in the table above covers the following conditions:

- (a) Single-conductor cable; two or three cables in the same metallic conduit.
- (b) Single-conductor shielded cable; two or three cables in the same metallic or nonmetallic duct or conduit, but only with conductor sizes up to 250 kcmils. For larger conductor sizes the short-circuited sheath losses increase rapidly and the table above does not apply.
- (c) Three-conductor nonshielded cable; one cable in metal conduit.
- (d) Three-conductor shielded cable; all conditions of use in air, in ducts and in conduit.

The table represents maximum AC losses for the conditions outlined.

## 7.6 TEMPERATURE CORRECTION FACTORS FOR RESISTANCE

Table 7.8—Temperature Correction Factors for the Resistance of Copper Conductors

Temp°C	Multiplying Factor
25	1.000
40	1.058
50	1.096
55	1.116
60	1.135
65	1.154
70	1.173
75	1.193
80	1.212
85	1.231
90	1.250
100	1.289
105	1.308
125	1.385
130	1.404
150	1.482
200	1.674

The DC resistance of copper wire increases with increasing temperature in accordance with the formula:

$$R_t = R_0 [1 + a (T - T_0)]$$

Where:

$R_t$  = Resistance at temperature T

$R_0$  = Resistance at temperature  $T_0$

a = Temperature coefficient of resistance at  $T_0$  [at 20°C (68°F) the temperature coefficient of copper is 0.00393 per degree Celsius]

## 7.7 VOLTAGE DROP

The values in **Tables 7.9** for copper conductors and **7.10** for aluminum conductors are calculated at 60°C, the estimated average temperature that may be anticipated in service. They may be used without significant error for conductor temperatures up to and including 75°C. For 90°C multiply by 1.102 for copper and by 1.105 for aluminum. To obtain values for other circuits, multiply by 1.155 for single-phase line-to-line and by 0.577 for single- or three-phase line-to-neutral.

$$\text{Voltage drop} = \frac{\text{Table value} \times \text{Current in amps} \times \text{Length of circuit in feet}}{100}$$

$$\text{Voltage drop in percent} = \frac{\text{Voltage drop in V} \times 100}{\text{Circuit voltage in V}}$$

**Table 7.9—Phase-to-Phase Voltage Drop Per Amp Per 100 ft. of Circuit for a Three-Phase, 60 Hz System Operating at 60°C with Copper Conductors**

Size (AWG/kcmil)	In Non-Magnetic Conduit			In Magnetic Conduit		
	Percent Power Factor			Percent Power Factor		
	80	90	100	80	90	100
12	0.2710	0.3030	0.3330	0.2720	0.3030	0.3320
10	0.1710	0.1910	0.2080	0.1720	0.1910	0.2080
8	0.1090	0.1200	0.1300	0.1100	0.1210	0.1300
6	0.0720	0.0790	0.0840	0.0730	0.0800	0.0840
4	0.0470	0.0510	0.0530	0.0480	0.0520	0.0530
2	0.0310	0.0330	0.0330	0.0320	0.0340	0.0340
1	0.0260	0.0270	0.0260	0.0260	0.0280	0.0260
1/0	0.0210	0.0220	0.0210	0.0220	0.0230	0.0210
2/0	0.0170	0.0180	0.0160	0.0190	0.0190	0.0170
3/0	0.0140	0.0150	0.0130	0.0160	0.0160	0.0140
4/0	0.0120	0.0120	0.0100	0.0140	0.0130	0.0110
250	0.0110	0.0110	0.0088	0.0120	0.0120	0.0093
300	0.0097	0.0095	0.0073	0.0110	0.0110	0.0078
350	0.0088	0.0085	0.0062	0.0100	0.0095	0.0067
400	0.0081	0.0076	0.0055	0.0095	0.0088	0.0061
500	0.0073	0.0067	0.0045	0.0085	0.0078	0.0050
600	0.0066	0.0059	0.0038	0.0080	0.0071	0.0042
700	0.0062	0.0055	0.0033	0.0074	0.0066	0.0037
750	0.0059	0.0054	0.0029	0.0073	0.0064	0.0035
1,000	0.0050	0.0043	0.0023	0.0066	0.0055	0.0023

## 7. Electrical Characteristics

**Table 7.10—Phase-To-Phase Voltage Drop Per Amp Per 100 ft. of Circuit for a Three-Phase, 60 Hz System Operating at 60°C with Aluminum Conductors**

Size  (AWG/kcmil)	In Non-Magnetic Conduit			In Magnetic Conduit		
	Percent Power Factor			Percent Power Factor		
	80	90	100	80	90	100
12	0.4240	0.4750	0.5230	0.4260	0.4760	0.5230
10	0.2680	0.2990	0.3290	0.2690	0.2140	0.3290
8	0.1700	0.1890	0.2070	0.1720	0.1910	0.2070
6	0.1110	0.1230	0.1330	0.1120	0.1230	0.1320
4	0.0710	0.0780	0.0830	0.0730	0.0790	0.0840
2	0.0460	0.0500	0.0520	0.0470	0.0510	0.0520
1	0.0380	0.0400	0.0420	0.0390	0.0410	0.0420
1/0	0.0310	0.0330	0.0330	0.0320	0.0340	0.0330
2/0	0.0250	0.0260	0.0260	0.0260	0.0270	0.0260
3/0	0.0210	0.0220	0.0210	0.0220	0.0230	0.0210
4/0	0.0170	0.0180	0.0170	0.0180	0.0180	0.0170
250	0.0150	0.0150	0.0140	0.0160	0.0160	0.0140
300	0.0130	0.0130	0.0120	0.0140	0.0140	0.0120
350	0.0120	0.0120	0.0099	0.0130	0.0130	0.0100
400	0.0110	0.0110	0.0087	0.0120	0.0120	0.0091
500	0.0092	0.0089	0.0070	0.0100	0.0099	0.0074
600	0.0083	0.0079	0.0059	0.0095	0.0088	0.0062
700	0.0076	0.0071	0.0050	0.0088	0.0082	0.0055
750	0.0073	0.0068	0.0048	0.0085	0.0079	0.0052
1,000	0.0068	0.0063	0.0042	0.0077	0.0069	0.0042

### 7.8 MAXIMUM CONDUCTOR SHORT CIRCUIT CURRENT

Because of the high kilovolt-ampere (kVA) capacity of many power systems, possible short circuit currents must be considered in power system design. A cable's maximum short circuit current rating is the maximum allowable current that the cable can withstand without damage. The maximum allowable short circuit current for copper and aluminum conductors can be determined with the aid of [Figures 7.1](#) and [7.2](#), respectively.

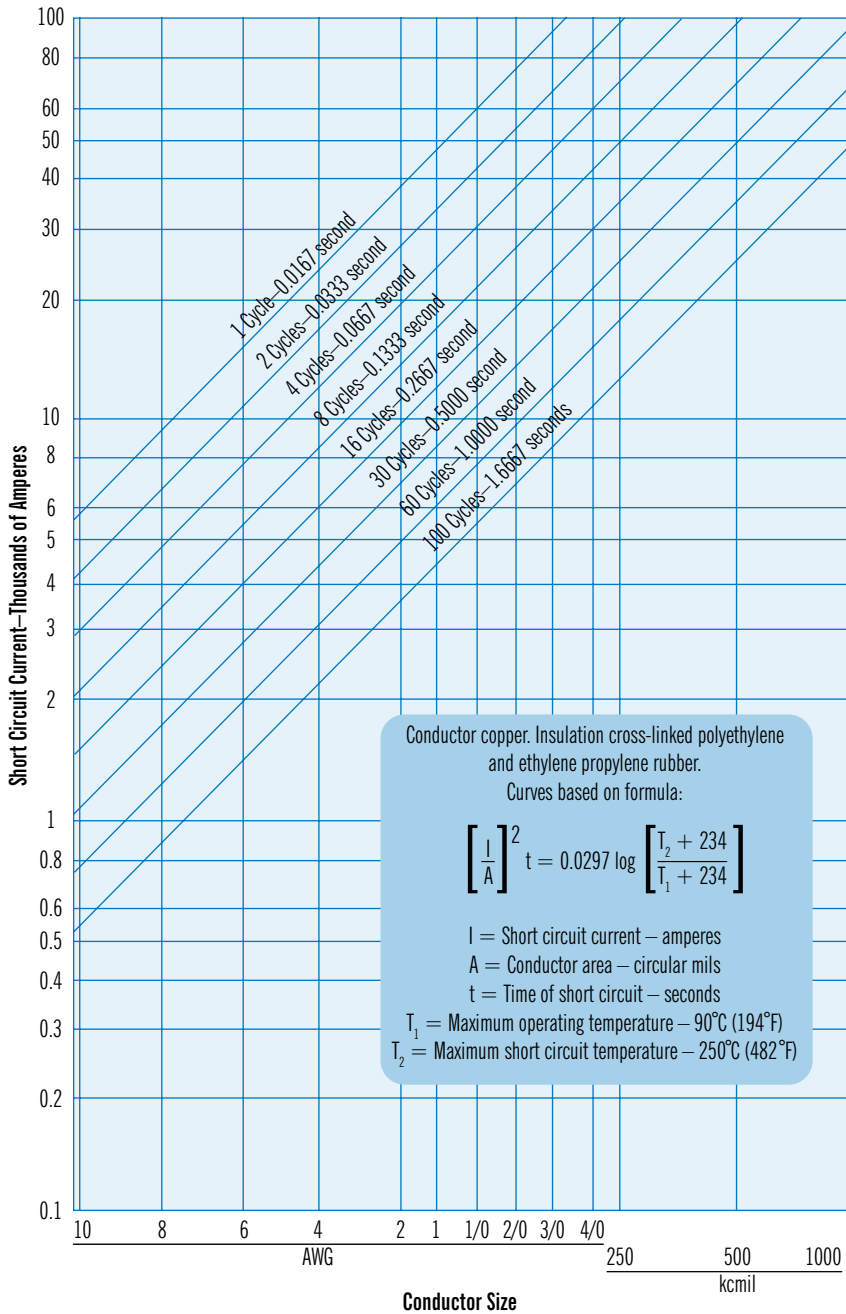

Source: ICEA P-32-382

Figure 7.1—Maximum Conductor Short Circuit Current for Copper Cables

7. Electrical Characteristics

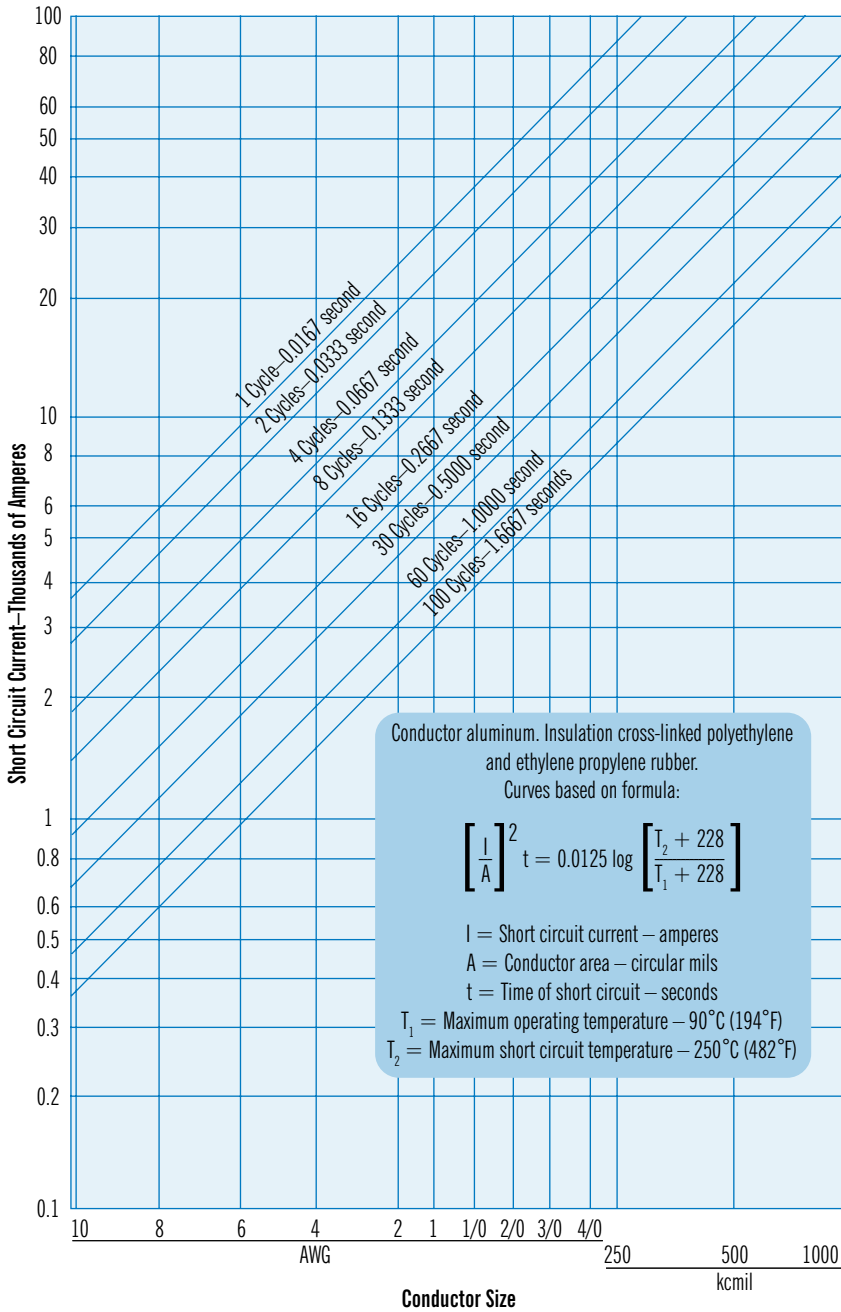

Source: ICEA P-32-382

Figure 7.2—Maximum Conductor Short Circuit Current for Aluminum Cables

## 7.9 MAXIMUM SHIELD SHORT CIRCUIT CURRENT

Table 7.11—Maximum Short Circuit Current for Copper Shielding Tape (Amperes)

Shield Dia. (in.)	Effective Shield Area (cmils)	Short Circuit Time (Number of Cycles at 60 Hz)						
		1	2	4	8	16	30	60
1/2	7,484	4,016	2,840	2,008	1,420	1,004	733	518
3/4	11,264	6,044	4,274	3,022	2,137	1,511	1,104	780
1	15,044	8,073	5,708	4,036	2,854	2,018	1,474	1,042
1 1/4	18,824	10,101	7,143	5,051	3,571	2,525	1,844	1,304
1 1/2	22,604	12,130	8,577	6,065	4,289	3,032	2,215	1,566
1 3/4	26,384	14,158	10,011	7,079	5,006	3,540	2,585	1,828
2	30,164	16,187	11,446	8,093	5,723	4,047	2,955	2,090
2 1/4	33,944	18,215	12,880	9,107	6,440	4,554	3,326	2,352
2 1/2	37,724	20,243	14,314	10,122	7,157	5,061	3,696	2,613
2 3/4	41,504	22,272	15,749	11,136	7,874	5,568	4,066	2,875
3	45,284	24,300	17,183	12,150	8,591	6,075	4,437	3,137

Source: ICEA P-45-482

Information in this chart is based on initial temperature of 65°C, final temperature of 200°C, 5 mil copper tape with 12.5 percent overlap.

## 7. Electrical Characteristics

### 7.10 RESISTANCE AND AMPACITY AT 400 AND 800 HZ

**Table 7.12—400 and 800 Hz Ampacity Factors for 600 V Copper Cables with Class B Strand, Installed with Minimum Triangular Spacing in Air or in Nonmetallic Conduit**

Conductor Size (AWG/kcmil)	Conductor Diameter (in.)	Cable Diameter (in.)	DC Resistance 75°C (ohms/1,000 ft.)	400 Hz		800 Hz	
				AC/DC Resistance Ratio	Ampacity Derating Factor*	AC/DC Resistance Ratio	Ampacity Derating Factor*
14	0.073	0.21	3.14	1.00	1.00	1.00	1.00
12	0.092	0.23	1.97	1.00	1.00	1.00	1.00
10	0.116	0.25	1.24	1.00	1.00	1.00	1.00
8	0.146	0.32	0.780	1.00	1.00	1.00	1.00
6	0.184	0.39	0.490	1.00	1.00	1.00	1.00
4	0.232	0.44	0.310	1.00	1.00	1.05	0.98
2	0.292	0.50	0.194	1.03	0.98	1.12	0.94
1	0.332	0.61	0.154	1.05	0.98	1.16	0.93
1/0	0.372	0.65	0.122	1.08	0.96	1.25	0.89
2/0	0.418	0.69	0.097	1.15	0.93	1.40	0.84
3/0	0.470	0.75	0.0767	1.22	0.90	1.53	0.81
4/0	0.528	0.81	0.0608	1.33	0.87	1.70	0.77
250	0.575	0.92	0.0515	1.40	0.84	1.82	0.74
350	0.681	1.08	0.0368	1.56	0.80	2.05	0.70
500	0.813	1.16	0.0258	1.90	0.72	2.54	0.63
750	0.998	1.38	0.0172	2.30	0.66	3.06	0.57
1,000	1.152	1.54	0.0129	2.60	0.62	3.44	0.54

Source: ICEA P-43-457

\* These derating factors do not apply to cables with metallic sheath or armor, nor to cables installed in conduit or adjacent to steel structures. Ampacity equals the 60 Hz ampacity multiplied by the derating factor.



## 7.11 CURRENT RATINGS FOR ELECTRONIC CABLES

The maximum continuous current rating for an electronic cable is limited by conductor size, number of conductors contained within the cable, maximum temperature rating of the cable and environmental conditions such as ambient temperature and airflow. To use the current capacity chart (Figure 7.3), first determine conductor gauge, temperature rating and number of conductors for the cable of interest.

Next, find the current value on the chart for the applicable temperature rise (temperature rating of cable minus ambient temperature) and conductor size. To calculate the maximum current rating per conductor, multiply the chart value by the appropriate conductor factor. The chart assumes the cable is surrounded by still air at an ambient temperature of 25°C. Current values are in RMS amperes and are valid for copper conductors only.

Note: Current ratings are intended as general guidelines for low power, electronic communications and control applications. Current ratings for power applications are published by codes and standards groups including NEC, UL, CSA, ICEA, NEMA, IEEE and IEC.

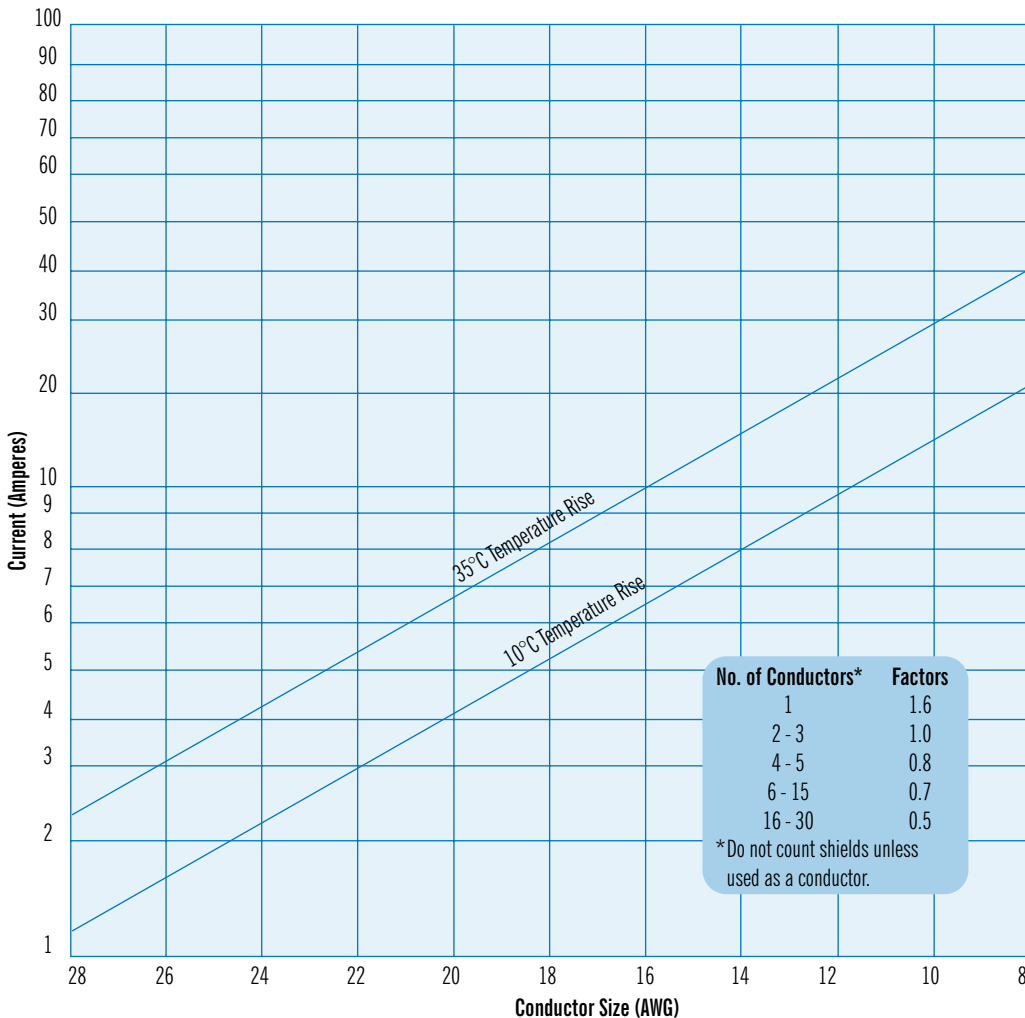

Figure 7.3—Current Ratings for Electronic Cables

## 7. Electrical Characteristics

### 7.12 AMPACITY OF POWER CABLES

The ampacity of a power cable depends primarily on its conductor size, conductor material (e.g., copper or aluminum), temperature rating, ambient temperature, installed cable configuration and other factors. Because so many external conditions affect ampacity, tables covering all situations are not possible. However, tables covering many common situations are available. Frequently used ampacity tables are contained in the following publications:

- NFPA Standard 70 National Electrical Code
- CSA Standard C22.1 Canadian Electrical Code
- IEEE Standard 835 Power Cable Ampacity Tables
- ICEA P-53-426 (NEMA WC 50) Ampacities Including Shield Losses for 15 Through 69 kV Cables
- ICEA P-54-440 (NEMA WC 51) Ampacities of Cables in Open-Top Cable Trays
- IEEE Standard 45 Recommended Practice for Installations on Shipboard

### 7.13 BASIC IMPULSE LEVEL (BIL) RATINGS

Electrical equipment, including wire and cable, is designed to withstand short-term, but very high-voltage pulses such as those sometimes caused by lightning and switching surges. These “spikes,” as they are sometimes called, typically have a risetime in the range of 1.5 microseconds and a falltime around 40 microseconds. The basic impulse level (BIL) is the maximum impulse voltage that a cable is designed to withstand. Common BIL ratings are shown below.

**Table 7.13—Basic Impulse Level (BIL) Ratings**

System Voltage Rating (kV)	Basic Impulse Level (kV)
2.5	60
5.0	75
8.0	95
15.0	110
25.0	150
35.0	200
69.0	350
138.0	650

Source: IEEE 82 Impulse Voltage Tests on Insulated Conductors

# 8. INSTALLATION AND TESTING

<b>8.1</b>	<b>Receiving, Handling and Storage</b>	<b>105</b>
	8.1.1 Receiving	105
	8.1.2 Handling	105
	8.1.3 Storage	105
<b>8.2</b>	<b>Conduit Fill</b>	<b>106</b>
<b>8.3</b>	<b>Pulling</b>	<b>111</b>
	8.3.1 Methods of Gripping Cables	111
	8.3.2 Tension Limitations	111
	8.3.3 Helpful Hints	112
	8.3.4 Pulling Tension Calculations	113
	8.3.5 Pulling Lubricants	114
	8.3.6 Sidewall Pressure (SWP)	114
	8.3.7 Minimum Bending Radii	115
<b>8.4</b>	<b>Installation Methods</b>	<b>116</b>
<b>8.5</b>	<b>Overhead Messengers</b>	<b>119</b>
<b>8.6</b>	<b>Vertical Suspension</b>	<b>121</b>
	8.6.1 Suspended by Clamping Around Cable	121
	8.6.2 Suspended by Conductor	121
<b>8.7</b>	<b>Hipot Testing</b>	<b>122</b>
	8.7.1 Test Equipment	122
	8.7.2 Test Procedure	122
	8.7.3 Test Voltage	124
	8.7.4 Evaluation of Results	124

# 8. INSTALLATION AND TESTING

<b>8.8</b>	<b>Fault Locating</b>	<b>124</b>
<b>8.9</b>	<b>Megger Testing</b>	<b>125</b>
<b>8.10</b>	<b>Moisture Removal</b>	<b>126</b>
	8.10.1 Purging Water from Conductor Strand or Shield	126
<b>8.11</b>	<b>Fiber Optic Testing</b>	<b>127</b>
<b>8.12</b>	<b>LAN Cable Testing</b>	<b>127</b>

This section is intended as a guide for the installer's use in the field. The information has been obtained from many sources and covers some of the major considerations when installing and testing power, control, instrumentation, fiber and communication cable.

## 8.1 RECEIVING, HANDLING AND STORAGE

---

The following guidelines are recommended to prevent possible deterioration or damage of cable during handling or storage prior to installation.

### 8.1.1 Receiving

Before accepting any shipment, all reels should be visually inspected for both hidden and obvious damage. Be especially alert if:

- A reel is lying flat on its side
- Reels are poorly stacked
- Protective covering (packaging material) is removed or damaged
- Cable end seals are removed or damaged
- Reel flanges are broken
- A reel has been dropped
- Cable ties are loose
- Nails or staples have been driven into the reel flange.

### 8.1.2 Handling

Cable reels should always be rolled in the direction of the "roll this way" stenciled on the flanges. This prevents loosening of the cable turns, which may cause problems during installation. If the roll direction is not indicated, rotate the reel in the same direction it was rotated when the cable was wound onto the reel.

Cable reels should only be lifted by forklift trucks from the sides and only if the forks are long enough to cradle both flanges.

Steel lifting bars of a suitable diameter and length should be used when lifting cable reels by crane or other overhead lifting devices. With heavy reels or reels that may be unbalanced, the use of a lifting yoke is recommended to prevent reels from slipping or tipping during lifting.

### 8.1.3 Storage

Where possible, reels should be stored indoors on a hard, dry surface. If reels must be stored outside they should be supported off the ground and covered with a suitable weatherproof material.

- Each reel should be aligned flange to flange.
- Each reel should be chocked.
- Reels should be stored to allow easy access for lifting and moving.

When cable lengths are cut from a master cable reel, all exposed cable ends should be resealed with plastic weatherproof caps or tape to prevent the entrance of moisture.

## 8.2 CONDUIT FILL

Below is a table of the maximum number of conductors that can be installed in electrical metallic tubing (EMT). The table is based on Table 1, Chapter 9 of the National Electrical Code. For installation in other types of conduits, for other wire types or for installation of compact stranded conductors, refer to Tables C1 through C12 in Annex C of the 2011 NEC.

**Table 8.1—Maximum Number of Conductors in Electrical Metallic Tubing (EMT)**

Type Letters	Conductor Size (AWG/kcmil)	Conduit or Tubing Trade Size (in.)									
		½	¾	1	1 ¼	1 ½	2	2 ½	3	3 ½	4
RHH, RHW RHW-2	14	4	7	11	20	27	46	80	120	157	201
	12	3	6	9	17	23	38	66	100	131	167
	10	2	5	8	13	18	30	53	81	105	135
	8	1	2	4	7	9	16	28	42	55	70
	6	1	1	3	5	8	13	22	34	44	56
	4	1	1	2	4	6	10	17	26	34	44
	3	1	1	1	4	5	9	15	23	30	38
	2	1	1	1	3	4	7	13	20	26	33
	1	0	1	1	1	3	5	9	13	17	22
	1/0	0	1	1	1	2	4	7	11	15	19
	2/0	0	1	1	1	2	4	6	10	13	17
	3/0	0	0	1	1	1	3	5	8	11	14
	4/0	0	0	1	1	1	3	5	7	9	12
	250	0	0	0	1	1	1	3	5	7	9
	300	0	0	0	1	1	1	3	5	6	8
	350	0	0	0	1	1	1	3	4	6	7
	400	0	0	0	1	1	1	2	4	5	7
	500	0	0	0	0	1	1	2	3	4	6
	600	0	0	0	0	1	1	1	3	4	5
700	0	0	0	0	0	1	1	2	3	4	
750	0	0	0	0	0	1	1	2	3	4	
800	0	0	0	0	0	1	1	2	3	4	
900	0	0	0	0	0	1	1	1	3	3	
1,000	0	0	0	0	0	1	1	1	2	3	
THHW, THW, TW THW-2	14	6	10	16	28	39	64	112	169	221	282
	12	4	8	13	23	31	51	90	136	177	227
	10	3	6	10	18	24	40	70	106	138	177
	8	1	4	6	10	14	24	42	63	83	106
	6	1	3	4	8	11	18	32	48	63	81
	4	1	1	3	6	8	13	24	36	47	60
	1/0	0	1	1	2	3	6	10	16	20	26
	2/0	0	1	1	1	3	5	9	13	17	22
3/0	0	1	1	1	2	4	7	11	15	19	

Continued >>

Table 8.1—Maximum Number of Conductors in Electrical Metallic Tubing (EMT) (Continued)

Type Letters	Conductor Size (AWG/kcmil)	Conduit or Tubing Trade Size (in.)									
		½	¾	1	1 ¼	1 ½	2	2 ½	3	3 ½	4
THHW, THW, TW THW-2	4/0	0	0	1	1	1	3	6	9	12	16
	250	0	0	1	1	1	3	5	7	10	13
	300	0	0	1	1	1	2	4	6	8	11
	350	0	0	0	1	1	1	4	6	7	10
	400	0	0	0	1	1	1	3	5	7	9
	500	0	0	0	1	1	1	3	4	6	7
	600	0	0	0	1	1	1	2	3	4	6
	700	0	0	0	0	1	1	1	3	4	5
	750	0	0	0	0	1	1	1	3	4	5
	800	0	0	0	0	1	1	1	3	3	5
	900	0	0	0	0	0	1	1	2	3	4
1,000	0	0	0	0	0	1	1	2	3	4	
THHN, THWN, THWN-2	14	12	22	35	61	84	138	241	364	476	608
	12	9	16	26	45	61	101	176	266	347	443
	10	5	10	16	28	38	63	111	167	219	27
	8	3	6	9	16	22	36	64	96	126	16
	6	2	4	7	12	16	26	46	69	91	11
	4	1	2	4	7	10	16	28	43	56	71
	3	1	1	3	6	8	13	24	36	47	60
	2	1	1	3	5	7	11	20	30	40	51
	1	1	1	1	4	5	8	15	22	29	37
	1/0	1	1	1	3	4	7	12	19	25	32
	2/0	0	1	1	2	3	6	10	16	20	26
	3/0	0	1	1	1	3	5	8	13	17	22
	4/0	0	1	1	1	2	4	7	11	14	18
	250	0	0	1	1	1	3	6	9	11	15
	300	0	0	1	1	1	3	5	7	10	13
	350	0	0	1	1	1	2	4	6	9	11
	400	0	0	0	1	1	1	4	6	8	10
	500	0	0	0	1	1	1	3	5	6	8
	600	0	0	0	1	1	1	2	4	5	7
	700	0	0	0	1	1	1	2	3	4	6
	750	0	0	0	0	1	1	1	3	4	5
800	0	0	0	0	1	1	1	3	4	5	
900	0	0	0	0	1	1	1	3	3	4	
1,000	0	0	0	0	1	1	1	2	3	4	

Continued &gt;&gt;

## 8. Installation and Testing

**Table 8.1—Maximum Number of Conductors in Electrical Metallic Tubing (EMT) (Continued)**

Type Letters	Conductor Size (AWG/kcmil)	Conduit or Tubing Trade Size (in.)									
		½	¾	1	1 ¼	1 ½	2	2 ½	3	3 ½	4
TFN, TFFN	18	22	38	63	108	148	244	—	—	—	—
	16	17	29	48	83	113	186	—	—	—	—
XHHW, XHHW-2	14	8	15	25	43	58	96	168	254	332	424
	12	6	11	19	33	45	74	129	195	255	326
	10	5	8	14	24	33	55	96	145	190	243
	8	2	5	8	13	18	30	53	81	105	135
	6	1	3	6	10	14	22	39	60	78	100
	4	1	2	4	7	10	16	28	43	56	72
	3	1	1	3	6	8	14	24	36	48	61
	2	1	1	3	5	7	11	20	31	40	51
	1	1	1	1	4	5	8	15	23	30	38
	1/0	1	1	1	3	4	7	13	19	25	32
	2/0	0	1	1	2	3	6	10	16	21	27
	3/0	0	1	1	1	3	5	9	13	17	22
	4/0	0	1	1	1	2	4	7	11	14	18
	250	0	0	1	1	1	3	6	9	12	15
	300	0	0	1	1	1	3	5	8	10	13
	350	0	0	1	1	1	2	4	7	9	11
	400	0	0	0	1	1	1	4	6	8	10
	500	0	0	0	1	1	1	3	5	6	8
	600	0	0	0	1	1	1	2	4	5	6
	700	0	0	0	0	1	1	2	3	4	6
750	0	0	0	0	1	1	1	3	4	5	
800	0	0	0	0	1	1	1	3	4	5	
900	0	0	0	0	1	1	1	3	3	4	
1,000	0	0	0	0	0	1	1	2	3	4	

Source: 2011 NEC, Annex C, Table C.1



Table 8.2—Maximum Cable Diameters for Permissible Conduit Fill

No. of Wires or Cables	Conduit Trade Size (in.)									
	½	¾	1	1 ¼	1 ½	2	2 ½	3	3 ½	4
	Actual ID of Conduit (in.)									
	0.622	0.824	1.049	1.38	1.61	2.067	2.731	3.356	3.834	4.334
Max. Diam. of Wires or Cables in Conduit (in.)										
1	0.453	0.600	0.764	1.005	1.172	1.505	1.988	2.443	2.791	3.155
2	0.245	0.324	0.413	0.543	0.634	0.814	1.075	1.321	1.509	1.706
3	0.227	0.301	0.383	0.504	0.588	0.755	0.997	1.225	1.400	1.583
4	0.197	0.261	0.332	0.436	0.509	0.654	0.864	1.061	1.212	1.371
5	0.176	0.233	0.297	0.390	0.455	0.585	0.772	0.949	1.084	1.226
6	0.161	0.213	0.271	0.356	0.416	0.534	0.705	0.867	0.990	1.119
7	0.149	0.197	0.251	0.330	0.385	0.494	0.653	0.802	0.917	1.036
8	0.139	0.184	0.235	0.309	0.360	0.462	0.611	0.750	0.857	0.969
9	0.131	0.174	0.221	0.291	0.339	0.436	0.576	0.708	0.808	0.914
10	0.124	0.165	0.210	0.276	0.322	0.413	0.546	0.671	0.767	0.867
11	0.119	0.157	0.200	0.263	0.307	0.394	0.521	0.640	0.731	0.826
12	0.114	0.150	0.192	0.252	0.294	0.377	0.499	0.613	0.700	0.791
13	0.109	0.145	0.184	0.242	0.282	0.363	0.479	0.589	0.673	0.760
14	0.105	0.139	0.177	0.233	0.272	0.349	0.462	0.567	0.648	0.733
15	0.102	0.135	0.171	0.225	0.263	0.338	0.446	0.548	0.626	0.708

Source: Based on 2008 NEC, Chapter 9, Table 1

**Table 8.3—Dimensions and Maximum Allowable Percent Fill of Electrical Metallic Tubing (EMT)**

Trade Size (in.)	Internal Dia. (in.)	Total Area (sq. in.)	Allowable Fill (sq. in.)		
			1 Cond. 53 percent Fill	2 Cond. 31 percent Fill	Over 2 Cond. 40 percent Fill
½	0.622	0.3	0.16	0.09	0.12
¾	0.824	0.53	0.28	0.17	0.21
1	1.049	0.86	0.46	0.27	0.35
1 ¼	1.38	1.5	0.79	0.46	0.6
1 ½	1.61	2.04	1.08	0.63	0.81
2	2.067	3.36	1.78	1.04	1.34
2 ½	2.731	5.86	3.1	1.82	2.34
3	3.356	8.85	4.69	2.74	3.54
3 ½	3.834	11.55	6.12	3.58	4.62
4	4.334	14.75	7.82	4.57	5.9

Source: 2011 National Electrical Code, Chapter 9, Table 4

For other conduit types, please refer to Table 4 in Chapter 9 of the NEC. The general equation for calculating wire or cable area is:

$$\text{Area in square inches} = \frac{\pi \times OD^2}{4} \times n$$

Where:

$$\pi = 3.14$$

OD = overall diameter of each single-conductor wire or multiconductor cable

n = number of wires or cables of that diameter

Example:

Pulling (3) 2/0 15 kV cables, each cable has an overall diameter of 1.20 inches.

Using the formula, solve as follows:  $\frac{3.14 \times 1.2^2}{4} = 3.39$  sq. in.

Referring to the table, minimum conduit size would be 4 inches.

---

## 8.3 PULLING

### 8.3.1 Methods of Gripping Cables

In general, insulated cables may be gripped either directly by the conductors or by a basket-weave pulling grip applied over the cables. The appropriate method to use depends on the anticipated maximum pulling tension. When pulls are relatively light a basket-weave grip can often be used. Heavier pulls usually require connecting directly to the conductor either by means of pulling eyes or by forming a loop with the conductor itself. In some instances it is desirable to use a grip over the outer covering in addition to the conductor connection to prevent any slippage of one with respect to the other.

#### Nonmetallic Sheathed Cables

Smaller sizes of nonmetallic sheathed cables can usually be gripped directly by the conductors by forming them into a loop to which the pull wire or rope can be attached. The insulation on each conductor is removed before the loop is formed. Larger sizes are more easily handled by applying a pulling grip over the cable or cables provided the pull is not too severe. If more than one cable is involved, the ends should be bound together with electrical tape before applying the grip overall. Long, hard pulls will necessitate the use of pulling eyes.

#### Interlocked Armor Cables

When pulling interlocked armor cable it is usually necessary to grip both the armor and the conductors. This can be accomplished in a number of ways. One method requires that a portion of the armor be removed. Electrical tape is then applied over the armor and down over the conductors and a long basket-weave grip is applied such that it grips both the armor and the conductors. Another method requires that two holes be drilled through the cable (armor and conductors) at right angles to each other and a loop formed by passing steel wires through the holes and out over the end of the cable. A third approach is to use a pulling eye and a grip together, the grip being applied over the armor to prevent it from slipping back. This latter approach provides the greatest strength.

#### Preassembled Aerial Cable

This type of cable should always be gripped by the messenger that is usually attached to a pulling swivel. In addition, a basket grip should be applied over the conductors to prevent any slippage and to facilitate guiding the conductors through the pulleys.

### 8.3.2 Tension Limitations

When the pulling force is applied directly to the conductor (e.g., when pulling eyes are used or when the conductor is formed into a loop) it should be limited to 0.008 lb. per circular mil area of cross-section for copper and 0.006 lb. per circular mil for aluminum.

When a grip is applied over nonmetallic sheathed cables, the pulling force should be limited to 1,000 pounds provided this is not in excess of the force calculated above using the 0.008 or 0.006 factors.

To limit the sidewall pressure to a safe value at bends in duct and conduit runs, the pulling force in pounds should not exceed 300 to 500 times the radius of the bend in feet.

The above limits are maximum values that should not be exceeded. However, it is possible to damage cables while applying lower tensions if, for example, there are sharp projections in a poorly constructed duct bank, or if an interlocked armor cable is pulled around too small a sheave. Every installation detail cannot be covered here but staying within the above tension limits will help ensure a successful installation.

**8.3.3 Helpful Hints**

The following suggestions – though not all-inclusive – will give greater assurance of success.

- (1) Be sure there is adequate clearance between conduit and cable. Clearance refers to the distance between the uppermost cable in the conduit and the inner top of the conduit. Clearance should be 1/4 inch at minimum and up to one inch for large cable installations or installations involving numerous bends. It is calculated as shown in **Figure 8.1** where “D” is the inner diameter of the conduit and “d” is the outer diameter of the cable. When calculating clearance, ensure all cable diameters are equal. Use the triplexed configuration formula if you are in doubt. The cables may be of single or multiple conductor construction. Do not exceed recommended “conduit fill” requirements.

No. of Conductors/Cables	Configuration	Formula
1		Clearance = D – d
3	 <p data-bbox="646 961 696 986">Cradled</p>	$\text{Clearance} = \frac{D}{2} - 1.366 + \frac{D-d}{2} \sqrt{1 - \left(\frac{d}{D-d}\right)^2}$
3	 <p data-bbox="642 1242 709 1267">Triplexed</p>	$\text{Clearance} = \frac{D}{2} - \frac{d}{2} + \frac{D-d}{2} \sqrt{1 - \left(\frac{d}{2(D-d)}\right)^2}$

Figure 8.1—How to Calculate Clearance

(2) Jamming is the wedging of three cables lying side by side in a conduit. This usually occurs when cables are being pulled around bends or when cables twist.

The jam ratio is calculated by slightly modifying the ratio  $D/d$ . A value of  $1.05D$  is used for the inner diameter of the conduit because bending a cylinder creates an oval cross-section in the bend.

- If  $1.05D/d$  is larger than 3.0, jamming is impossible.
- If  $1.05D/d$  is between 2.8 and 3.0, serious jamming is probable.
- If  $1.05D/d$  is less than 2.5, jamming is impossible but clearance should be checked.

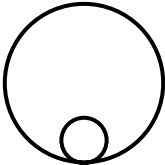
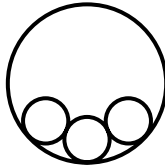
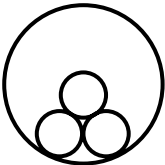
Because there are manufacturing tolerances on cable, the actual overall diameter should be measured prior to computing the jam ratio.

- (3) Use adequate lubrication of the proper type to reduce friction in conduit and duct pulls. Grease and oil type lubricants should not be used on nonmetallic sheathed cables. There are a number of commercially available wire pulling compounds (many of which are UL Listed) that are suitable for use with polymer jacketed cables. They usually consist of soap, talc, mica or the like, and are designed to have no deleterious effect on the cable. Graphite and other electrically conducting lubricants should not be used on nonshielded cables rated 2 kV and above. These materials can lead to tracking of the cable jacket.
- (4) Avoid sharp bending of the cable at the first pulley in overhead installations by locating the payoff reel far enough away from the first pulley that the lead-in angle is kept relatively flat.
- (5) After installation, check that end seals are still intact and have not been damaged to the point where water could enter. Apply plastic or rubber tape to help protect against invisible damage if the cable will be subjected to immersion or rain. This is particularly important if there will be a delay of some time between the pulling operation and splicing and terminating.
- (6) When installing interlocked armor cables in cable tray, use a sufficient number of rollers to prevent the cable from dragging on the tray, which might result in excessive tension. Avoid sharp bends in the cable by using a conveyor sheave with multiple small rollers at all 45- and 90-degree bends.
- (7) Keep adequate tension on the messenger in aerial cable installations to prevent sharp bends at pulleys. Do not release the tension on the messenger until it is secured to poles on both ends.

### 8.3.4 Pulling Tension Calculations

Pulling tension calculations are recommended in the design stage of all cable installations that are expected to fall in the moderate to difficult category. Software programs are commercially available that can perform sophisticated modeling of expected pulling tensions and sidewall pressures. These programs are recommended over manual methods. Below is an overview of the basic calculations. Additional information is available in IEEE 1185, IEEE 971, IEEE 576 and AEIC CG5.

#### (1) Maximum Pulling Tension

- With pulling eye attached to copper conductors, the maximum pulling tension in pounds should not exceed 0.008 times the circular mil area.
- With pulling eye attached to aluminum conductors, the maximum pulling tension in pounds should not exceed 0.006 times the circular mil area.

Example: For copper

$$T_M = 0.008 \times n \times CM$$

Where:

$$T_M = \text{maximum tension, lb.}$$

$$n = \text{number of conductors}$$

$$CM = \text{circular mil area of each conductor}$$

**(2) Maximum Permissible Pulling Length:**

$$L_M = \frac{T_M}{C \times W}$$

Where:

$L_M$  = maximum pulling length, feet (valid only for straight sections)

$T_M$  = maximum tension, lb.

$W$  = weight of cable per foot, lb.

$C$  = coefficient of friction (typically 0.5 but can vary from 0.2 to 1.0 depending on condition of the duct and the amount of lubricant used)

**(3) Bend Multipliers**

For a curved section, the multipliers given below are applied to the tension calculated for the straight section preceding the bend.

**Table 8.4—Bend Multipliers for Pulling Tension Calculations**

Bend Angle Degrees	Multiplier	Bend Angle Degrees	Multiplier
15	1.14	75	1.94
30	1.30	90	2.20
45	1.48	105	2.50
60	1.70	120	2.86

Note: These multipliers are based on a coefficient of friction of 0.5. If the coefficient of friction were 1.0 instead of 0.5, the multipliers would have to be squared. If the coefficient of friction were 0.75, the multipliers would be raised to the one and one-half power.

**8.3.5 Pulling Lubricants**

Many commercial lubricants are available and may be employed to reduce pulling tensions provided they do not affect electrical or mechanical characteristics of the cable. The primary function of a pulling lubricant is to reduce the tension on the cable as it is installed in a duct. This is accomplished by reducing the friction (technically the coefficient of friction) between the cable and the inside surface of the conduit, i.e., it makes the cable more slippery. Cable pulling lubricants should be formulated for the conditions of the pull, be safe for the environment, not degrade the cable jacket and be easy to work with. Some LSZH (low smoke zero halogen) cables require special pulling lubricants such as Polywater LZ to prevent chemical damage to the jacket.

The quantity of lubricant required depends on various factors: The pull length, the condition and size of the conduit and the difficulty of the pull. The recommended average quantity of lubricant per pull is equal to:

$$Q = 0.0015 \times L \times D$$

Where Q is the quantity of lubricant needed in gallons, L is the length of the pull in feet and D is the inner diameter of the conduit in inches.

The appropriate quantity to use can vary by ± 50 percent from the average depending on installation conditions. Follow the manufacturer’s instructions for the conditions affecting each pull.

**8.3.6 Sidewall Pressure (SWP)**

To prevent damage to a cable from pressure that develops when a cable is pulled around a bend under tension, the pressure must be kept as low as possible and should not exceed specified values. Sidewall pressure = tension out of the bend divided by the radius of the bend. Cable manufacturers generally recommend a maximum SWP of 500 lb./ft. for most 600 V and medium-voltage power cables.

### 8.3.7 Minimum Bending Radii

#### Power Cables without Metallic Shielding

The minimum bending radii for both single- and multiple-conductor cable without metallic shielding are as follows:

**Table 8.5—Minimum Bending Radii for Cables without Metallic Shielding**

Thickness of Conductor Insulation (mils)	Minimum Bending Radius as a Multiple of Cable Diameter		
	Overall Diameter of Cable in Inches		
	1.00 and less	1.01 to 2.00	2.01 and Greater
169 and less	4	5	6
170 and larger	5	6	7

#### Example:

If minimum bending radius is six times cable O.D. and cable O.D. is 2.0 inches, the minimum bending radius is 12 inches (minimum bending diameter is 24 inches).

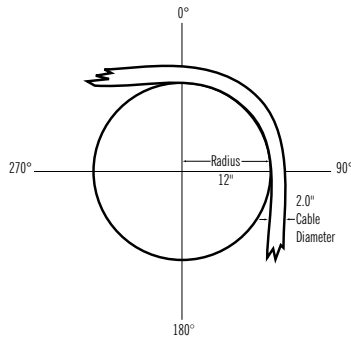

**Figure 8.2—Calculating Minimum Bending Radius**

#### Power Cables with Metallic Shielding

The minimum bending radius for all single-conductor cables with metallic shielding is 12 times the overall diameter of the cable. For multiconductors, it is seven times the overall diameter or 12 times the individual conductor diameter, whichever is greater.

#### Portable Cables

The minimum bending radius for portable cables during installation and handling in service is six times the cable diameter for cables rated 5,000 volts and less. For cables rated over 5,000 volts use eight times the cable diameter. For flat twin cables, the minor diameter is used to determine the bending radius.

#### Fiber Optic Cables

Minimum bending radius for fiber optic cable is typically 10 times the cable diameter when under no tension and 15 times diameter at rated maximum tension. The manufacturer should be consulted for specific product limits.

#### Interlocked Armor or Corrugated Sheath (Type MC) Cables

The minimum bending radius for Type MC cable is seven times the external diameter of the metallic sheath.

Sources: NEC Articles 300.34, 330.24, 336.24 and 727.10; NEMA WC58 (ICEA S-75-381); NEMA WC74 (ICEA S-93-639); IEEE 1185; NEMA WC70 (ICEA S-95-658)

8.4 INSTALLATION METHODS

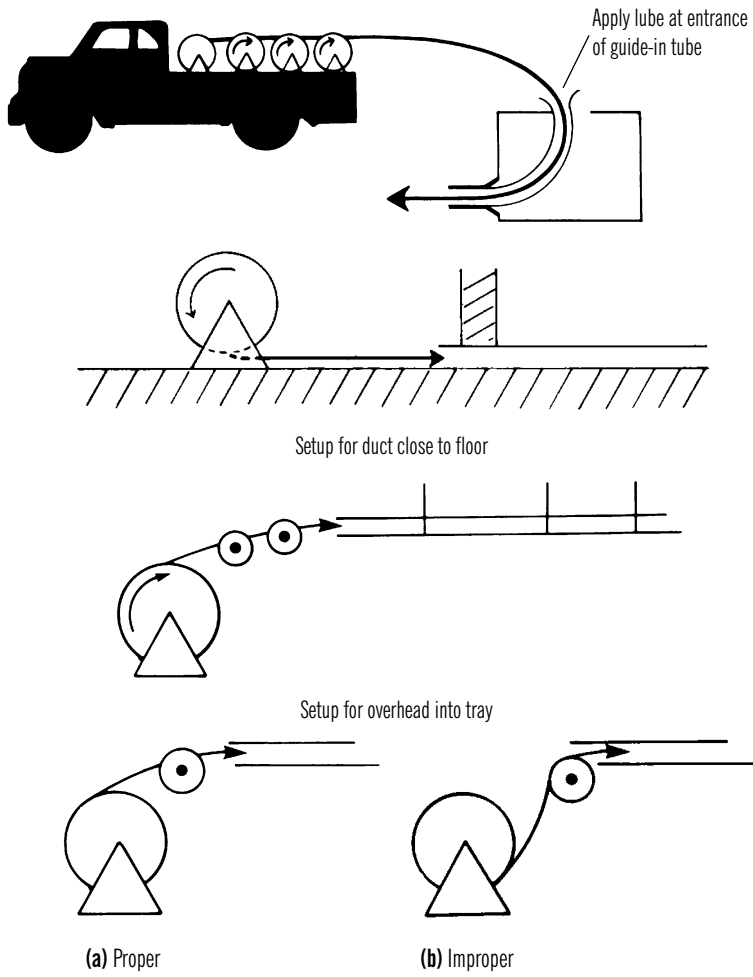

The feed-in setup should unreel the cable with the natural curvature (a) as opposed to a reverse “S” curvature (b).

Figure 8.3—Cable Pulling Setups

Continued >>



8.4 INSTALLATION METHODS (CONTINUED)

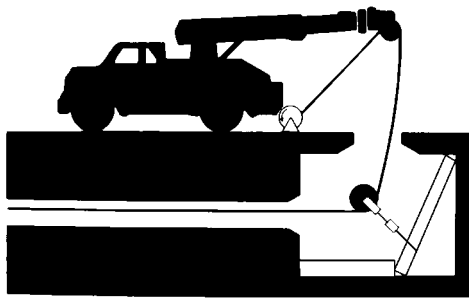
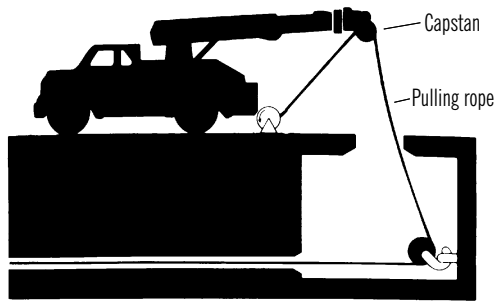

A setup with timbers because pulling eyes were not available

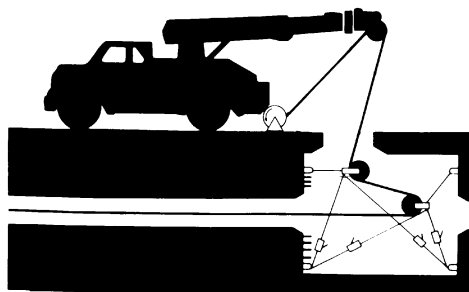
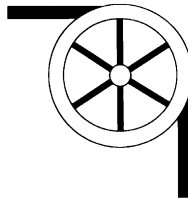

Figure 8.3—Cable Pulling Setups

Continued >>

8.4 INSTALLATION METHODS (CONTINUED)

Single sheave



Single sheaves should be used only for guiding cables. Arrange multiple blocks if necessary to maintain minimum bending radii whenever cable is deflected.

Sheave assembly

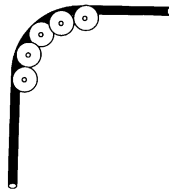

For pulling around bends, use multisheave assemblies

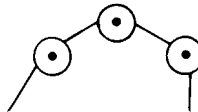

The pulleys must be positioned to ensure that the effective curvature is smooth and deflected evenly at each pulley. Never allow a polygon curvature to occur as shown.

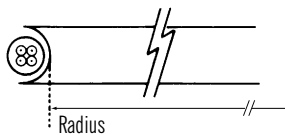

The fit of the pulley around the cable is also important when the pulling tension is high (for example, pulleys at the top of a vertical drop). Remember to use the radius of the surface over which the cable is bent, not the outside flange diameter of the pulley.

A 10-inch cable sheave typically has an inside (bending) radius of 3 inches!

Figure 8.3—Cable Pulling Setups

## 8.5 OVERHEAD MESSENGERS

**Table 8.6—Messenger Breaking Strength in lb.**

Nominal Messenger Size	30 percent EHS* Copper-Clad Steel	Aluminum Clad Steel	EHS* Galvanized Steel	High-Strength Galvanized Steel	Type 316 Stainless Steel	Type 302 Stainless Steel
1/4 in. (7312 AWG)	6,282	6,301	6,650	4,750	7,650	8,500
5/16 in. (7310 AWG)	9,196	10,020	11,200	8,000	11,900	13,200
3/8 in. (738 AWG)	13,890	15,930	15,400	10,800	16,200	18,000
7/16 in. (737 AWG)	16,890	19,060	20,800	14,500	23,400	26,000
1/2 in. (736 AWG)	20,460	22,730	26,900	18,800	30,300	33,700

\* Extra-High Strength

**Table 8.7—Messenger Weight in lb./1,000 ft.**

Nominal Messenger Size	30 percent EHS* Copper-Clad Steel	Aluminum Clad Steel	EHS* Galvanized Steel	High-Strength Galvanized Steel	Type 316 Stainless Steel	Type 302 Stainless Steel
1/4 in.	139	104	121	121	136	132
5/16 in.	204	165	205	205	208	208
3/8 in.	324	262	273	273	278	278
7/16 in.	408	330	399	399	405	405
1/2 in.	515	416	517	517	525	525

**Table 8.8—Maximum Core Weight in lb./ft. (Based on Final Sag of 30 in. at 60°F in a 150 ft. Span, 30 Percent of Breaking Strength)**

Nominal Messenger Size	30 percent EHS* Copper-Clad Steel	Aluminum Clad Steel	EHS* Galvanized Steel	High-Strength Galvanized Steel	Type 316 Stainless Steel	Type 302 Stainless Steel
1/4 in.	1.5	1.5	1.6	1.1	1.8	2.1
5/16 in.	2.2	2.4	2.7	1.9	2.9	3.3
3/8 in.	3.3	3.9	3.8	2.6	3.9	4.5
7/16 in.	4.0	4.7	5.1	3.4	5.8	6.5
1/2 in.	4.9	5.6	6.6	4.4	7.5	8.4

## 8. Installation and Testing

**Table 8.9—Galvanized Steel Strand/Physical Specifications**

Nominal Messenger Size (in.)	Grade	Weight lb./1,000 ft.	Minimum Strength lb.
3/16	Common	73	1,150
3/16	Utility 2.2 M	73	2,400
1/4	Common	121	1,900
1/4	Siemens Martin	121	3,150
1/4	High Strength	121	4,750
1/4	Extra High Strength	121	6,650
5/16	Common	205	3,200
5/16	Siemens Martin	205	5,350
5/16	Utilities Grade 6 M	225	6,000
5/16	High Strength	205	8,000
5/16	Extra High Strength	205	11,200
3/8	Common	273	4,250
3/8	Siemens Martin	273	6,950
3/8	Utility 10 M	273	11,500
3/8	High Strength	273	10,800
3/8	Extra High Strength	273	15,400
7/16	Siemens Martin	399	9,350
7/16	High Strength	399	14,500
7/16	Utility 16 M	399	18,000
1/2	Siemens Martin	517	12,100
1/2	High Strength	517	18,800
1/2	Utility 25 M	517	25,000

Class A: Minimum amount of zinc coating.

Class B: Twice the amount of zinc coating as Class A.

Class C: Three times the amount of zinc coating as Class A.

Additional information on overhead messengers is available in ICEA P-79-561 Guide for Selecting Aerial Cable Messengers and Lashing Wires.

## 8.6 VERTICAL SUSPENSION

### 8.6.1 Suspended By Clamping Around Cable

Table 8.10—Spacings for Conductor Supports

Maximum Support Spacing for Conductors in Vertical Raceways		
AWG or Circular Mil Size of Wire	Aluminum or Copper-Clad Aluminum	Copper
18 AWG through 8 AWG	100 ft.	100 ft.
6 AWG through 1/0 AWG	200 ft.	100 ft.
2/0 AWG through 4/0 AWG	180 ft.	80 ft.
over 4/0 AWG through 350 kcmil	135 ft.	60 ft.
over 350 kcmil through 500 kcmil	120 ft.	50 ft.
over 500 kcmil through 750 kcmil	95 ft.	40 ft.
over 750 kcmil	85 ft.	35 ft.

Source: 2011 NEC, Article 300.19

### 8.6.2 Suspended by Conductor

Additional information on vertically suspended cables is available in NEMA WC 70 (ICEA S-95-658) Section 4.4.1 and in NEMA WC 74 (ICEA S-93-639) Section 7.4.1.

$$F = \frac{A \times T}{W \times L} \quad \text{Where}$$

- A = conductor area in sq. in.
- T = conductor tensile strength in lb./sq. in.
- W = cable weight in lb./ft.
- L = length in feet
- F = safety factor (must be at least 7.0 unless otherwise required by appropriate authority)

Example:

Suspend 470 ft. of cable having three 4/0 AWG (211,600 circular mils each) soft-drawn copper conductors, total cable weight is 3,240 lb./1,000 ft. or 1,080 lb./1,000 ft. per conductor, each conductor is supported at the top with a full tension terminal:

$$F = \frac{(211,600) (\pi/4) (1,000,000) (36,000)}{(1,080/1,000) 470} = 11.8 \text{ (OK)}$$

If the suspended cable is installed in a conduit elbow at the top, check sidewall loading.

### 8.7 HIPOT TESTING

---

#### Overview

This section provides an overview of high-potential DC testing of power cables. For more details, see IEEE Standards 400 and 400.1. All tests made after cable installation and during the manufacturer's guarantee period should be made in accordance with applicable specifications. All safety precautions must be observed during testing at high voltage. Read and understand and follow the operator's manual for the particular test set being used.

It should be also noted that other field tests are growing in popularity—including VLF (very low frequency) and PD (partial discharge) test methods. IEEE 400.2 and 400.3 contain additional details.

#### 8.7.1 Test Equipment

Direct current test equipment is commercially available with a wide range of voltages. Accessory equipment is necessary to safely conduct high-voltage tests such as safety barriers, rubber gloves and nonconducting hard hats. Always consult an appropriate safety officer.

#### 8.7.2 Test Procedure

Refer to IEEE Standard 400. Acceptable procedures, although varying slightly in technique, have more or less been standardized as either a “withstand test” or a “time-leakage current test.”

Before performing any DC overpotential tests:

- All equipment must be disconnected from the cable circuit, e.g., disconnect transformers, switch taps, motors, circuit breakers, surge arrestors, etc. This will preclude damage to such equipment and will prevent test interruptions due to flashovers and/or trip-outs resulting from excessive leakage current.
- Establish adequate clearance between the circuit test ends and any grounded object, and to other equipment not under test (approximately 0.25 inches per kV).
- Ground all circuit conductors not under test and all cable shields as well as nearby equipment.
- Consult termination manufacturer for maximum test voltage recommendations and time limitations.

The direct current test may be applied either continuously or in predetermined steps to the maximum value in accordance with applicable specifications:

- **Continuous Method** — Apply test voltage at an approximate rise rate of 1 kV per second or 75 percent of the rated current input of the equipment, whichever is less. Some equipment will take longer to reach the maximum test voltage because of the amount of charging current.
- **Step Method** — Apply test voltage slowly in five to seven increments of equal value, to the maximum specified. Allow sufficient time at each step for the leakage current to stabilize. Normally this requires only a few seconds unless cable circuits of high capacitance are involved. Record leakage current at each step.
- Maintain the test voltage at the prescribed value for the time designated in applicable specifications.
- At the end of the test period, set the test set voltage control to zero. Allow the residual voltage on the circuit to decay then ground the conductor just tested.
- **Caution** — It should be recognized that DC charges on cable can build up to potentially dangerous levels if grounds are removed too quickly. Maintain solid grounds after the test on the cable for at least four times the duration of the test. It is a good safety practice to maintain these grounds longer and while reconnecting circuit components.

**Acceptance Testing** — After installation and before the cable is placed in regular service the specified test voltage is applied for 15 consecutive minutes.

**Proof Testing** — At any time during the period of guarantee, the cable circuit may be removed from service and tested at a reduced voltage (normally 65 percent of the original acceptance value) for five consecutive minutes.

Record the leakage current at one minute intervals for the duration of the test. A constant or decreasing leakage current with respect to time at maximum test voltage is the usual acceptance criterion for DC hipot testing.

### Additional Considerations

High-potential testing of medium-voltage power cables is usually performed with negative polarity connected to the conductor.

High-potential testing is a tool for determining insulation resistance at high voltages. Effective insulation resistance of the cable system may be calculated by means of Ohm's Law:  $R = 5 V/I$ . Restated another way the relation is:

$$\text{Megohms} = \frac{\text{Kilovolts}}{\text{Microamperes}} \times 1,000$$

Insulation resistance (IR) may also be measured with instruments that give a direct reading at 500 volts (or higher, depending on the model). IR in general has little or no direct relationship to breakdown strength.

The significance of conducting DC high-voltage tests on nonshielded, nonmetallic sheathed cable is dependent upon the environment in which it is installed because the characteristics of the return circuits are unknown. The environment must be carefully considered or test results may not be significant. In fact, these tests can result in damage to the cable insulation.

Humidity, condensation or actual precipitation on the surface of a cable termination can increase the leakage current by several orders of magnitude. Humidity also increases the termination leakage current, which is included in the total leakage current. Wind prevents the accumulation of space charges at all bare energized terminals. This results in an increase of corona. It is desirable to reduce or eliminate corona current at the bare metal extremities of cable or terminations. This may be accomplished by covering these areas with plastic envelopes, plastic or glass containers, plastic wrap (e.g., Saran<sup>®</sup> or Handiwrap<sup>®</sup>) or suitable electrical putty.

Routine periodic DC maintenance testing of cable for the evaluation of the insulation strength is not a common practice. Some power cable users have adopted a program of testing circuits during planned outages, preferring possible breakdowns during testing rather than experiencing a service outage. It is nearly impossible to recommend test voltage values for maintenance. An arbitrary test voltage level could break down a cable circuit that would otherwise render long trouble-free service at normal operating AC voltage.

One advantage of DC high-voltage testing is that it can detect conducting particles left on the creepage surface during splicing or termination.

Test equipment should be supplied from a stable, constant voltage source. Do not use the same source that is supplying arc welders or other equipment causing line voltage fluctuations. The output voltage of the test set must be filtered and regulated. Consider using a portable motor driven alternator to energize the test set.

### Common Testing Problems

High-leakage current can be caused by:

- Failure to guard against corona
- Failure to clean insulation surface
- Failure to keep cable ends dry (high relative humidity, dampness, dew, fog, wind, snow)
- Failure to provide adequate clearance to ground
- Improper shield termination.

Erratic readings can be caused by:

- Fluctuating voltage to test set
- Improper test leads.

**8.7.3 Test Voltage**

DC hipot test voltages are specified by ICEA and NEMA for tests conducted during and after installation as follows:

- At any time during installation, a DC proof test may be made at a voltage not exceeding the test voltage specified below, applied for five consecutive minutes.
- After the cable has been completely installed and placed in service, a DC proof test may be made at any time within the first five years at the test voltage specified below, applied for five consecutive minutes. After that time, DC testing is not recommended.

**Table 8.11—Maximum DC Test Voltages for Shielded Power Cables**

Rated Voltage	Maximum DC Field Test Voltages in kV			
	During Installation		First Five Years	
Phase-to-Phase (kV)	100 Percent (Grounded)	133 Percent (Ungrounded)	100 Percent (Grounded)	133 Percent (Ungrounded)
5	28	36	9	11
8	36	44	11	14
15	56	64	18	20
25	80	96	25	30
28	84	100	26	31
35	100	124	31	39
46	132	172	41	54

Sources: ICEA S-94-649 Appendix E, NEMA WC 74 (ICEA S-93-639) Appendix F and ICEA S-97-682 Appendix E

**8.7.4 Evaluation of Results**

The test current will momentarily increase for each voltage increment due to the charging of capacitance and dielectric absorption characteristics of the cable—ultimately leaving only the conduction current plus any external surface leakage or corona currents. The time required to reach steady-state current depends on insulation temperature and material. If, without any increase in applied voltage, the current starts to increase slowly at first but at an increasing rate, gradual insulation failure may be in progress. This process will probably continue until eventual failure of the cable unless the voltage is rapidly reduced. Rubber and nonpressurized impregnated paper insulations will usually exhibit this type of insulation failure; other insulations rarely exhibit this type of failure.

If at any time during the test, a violent increase in current occurs accompanied by tripping of the test set, failure or flashover has probably occurred in the cable, a splice or termination. A failure can be confirmed by the inability to sustain the second application of the test voltage.

**8.8 FAULT LOCATING**

One of the many types of fault locating equipment is the time domain reflectometer (TDR). These units are portable, commercially available devices that can be used in the field to locate some types of conductor breaks or shorts. Connected to the end of a cable, the device functions much like radar, sending out low-voltage pulses that travel the length of the cable and echo back when an open, short or tap is encountered. The device can usually locate faults within ± 2 percent of the cable length. However, TDRs are only capable of locating breaks or shorts having an impedance different than that of the cable. For most cables, this includes shorts having a resistance of less than a few ohms and opens having a resistance greater than several hundred ohms. Splices, taps, etc., sometimes distort the echo and can mask the fault. Nevertheless, the method is nondestructive and is used successfully on faults having characteristics within the capabilities of the method.



## 8.9 MEGGER TESTING

If the DC voltage applied during an insulation resistance (IR) test on power cables is relatively low (0.6 to 2.5 kV), the test is often referred to as a “Megger” test. Low-voltage IR tests are particularly useful in detecting shorts due to installation or handling damage to 600-volt-rated cables.

An inherent limitation of low-voltage IR tests is their interpretation. The readings obtained from such testing on nonshielded, nonmetallic-sheathed cable is very dependent upon the environment because the environment determines the characteristics of the return circuit. Low resistance readings may be caused by contaminated or moist cable ends, high humidity, etc. Failure to clean water-based cable pulling lubricants from the cable test ends has caused erroneous rejection of good cable. Refer to the figures below for suggested hook-up.

Reminders:

- **Safety** – Follow the test equipment supplier’s instructions. Stay clear of energized cable. Operators must know the equipment. Be sure shields are grounded! Remember that insulated conductors are capacitors.
- **Voltages** – Check cable and termination manufacturer’s guidelines.
- **Records** – Keep detailed records and provide a copy to the owner.

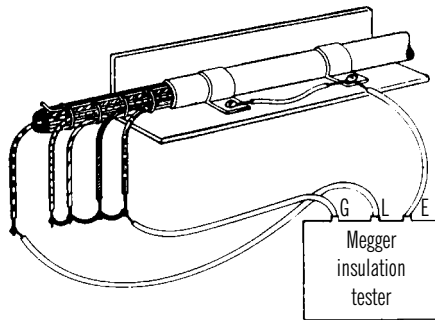

Figure 8.4—Connections for Testing Insulation Resistance Between One Wire and Ground, Without Being Affected by Leakage to Other Wires. Note Use of the Guard (G) Connection

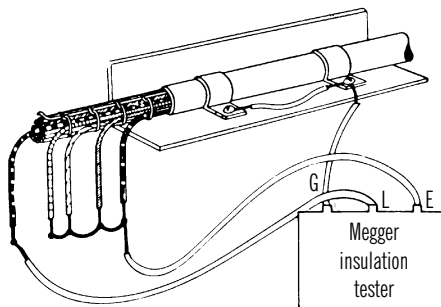

Figure 8.5—Connections for Testing Insulation Resistance Between One Wire and All Other Wires, Without Being Affected by Leakage to Ground

## 8.10 MOISTURE REMOVAL

### 8.10.1 Purging Water from Conductor Strand or Shield

**Cables Not Yet Installed:** Remove end seals. Position one cable end to its lowest possible elevation. At the cable end having the highest elevation, apply two layers of half-lapped HV insulating tape to act as a sealing cushion. Connect the cable ends to a dry nitrogen or dry air supply using hoses, valves, fittings and flow regulators as shown in [Figure 8.6](#).

Attach a one-gallon plastic bag to the exhaust end of the cable. Secure the bag with tape or clamps. Make a small vent hole by clipping one bag corner. As shown, several cables may be connected to the gas supply. Dry nitrogen is available from welding gas suppliers. Apply 15–25 psi (gauge). Maintain gas flow for at least eight hours after all indications of moisture have stopped.

Water vapor may be readily detected by sprinkling one tablespoon of anhydrous cupric sulfate in the plastic bag, which turns blue instead of “off” white when wet. The sulfate is available from scientific laboratory supply houses. A hardware store humidity gauge may also be used.

**Installed Cables:** The splices and terminations must be removed if they interfere with the flow of air or nitrogen. The cable can then be purged as described above.

**All Cables:** Purge the shield separately from the insulated strands; otherwise the nitrogen gas will only flow through the path offering the least resistance.

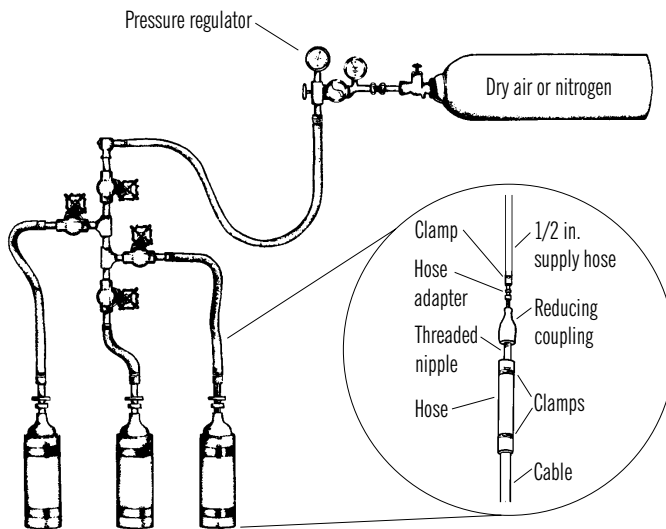

Figure 8.6—Moisture Removal Equipment

## 8.11 FIBER OPTIC TESTING

---

Testing a newly installed fiber optic system can increase the overall performance of a system, decrease the amount of downtime and reduce costs for the system owner. Attenuation is the parameter most frequently measured and includes the attenuation of the cable as well as that of attached connectors. Cable attenuation can be caused by microbending of the fiber, impurities in the fiber, excessive mechanical force on the cable or, of course, a broken fiber.

Handheld optical power meters and light sources are used to determine the total attenuation of the fiber including any splices or connectors. With this method the light source injects light with a known signal level (brightness) into one end of the fiber. The power meter is attached to the other end of the fiber and measures the light output at a specific wavelength. The difference is the attenuation and is usually reported in decibels.

Optical time domain reflectometers (OTDRs) are used to locate faults and to measure attenuation of cables and connectors. A light pulse is sent down the fiber and as it encounters a fault, connector, splice, etc., a portion of the optical pulse is reflected back to the source. An OTDR is able to determine the distance to the reflection and the amount of signal loss at that point. OTDRs work on a radar-like principle.

Small optical microscopes are used to visually inspect the workmanship of installed fiber optic connectors.

## 8.12 LAN CABLE TESTING

---

With society's dependency on data networks around the world, the ability to maintain proper system operation is extremely important. There are several types of test equipment that are commonly used to evaluate local area network (LAN) unshielded twisted-pair (UTP) and shielded twisted-pair (STP) cabling.

Low-cost handheld LAN cable testers are available to certify the electrical performance, e.g., Category 3, 4, 5 or 6, of newly installed LAN cable. These devices typically characterize the installed system with regard to crosstalk, attenuation, impedance and other parameters.

Time domain reflectometers (TDRs) are devices used to locate faults, determine length and measure attenuation of the cable. The TDR sends a low-voltage pulse along the cable and then "looks" for reflections that result from impedance mismatches that are caused by shorts, opens or severely deformed cable. TDRs analyze the reflections and report the magnitude of the impedance mismatch and the location of faults.



# 9. CABLE ACCESSORIES

<b>9.1</b>	<b>Coaxial Connectors</b>	<b>131</b>
9.1.1	Selection	131
9.1.2	BNC	131
9.1.3	TNC	131
9.1.4	SHV	131
9.1.5	SMA	132
9.1.6	UHF	132
9.1.7	N Series	133
9.1.8	F Series	133
<b>9.2</b>	<b>Data Connectors</b>	<b>133</b>
9.2	RJ11 and RJ45 Modular	133
<b>9.3</b>	<b>Power Connectors</b>	<b>134</b>
9.3.1	Selection	134
9.3.2	Stud Sizes	136
<b>9.4</b>	<b>Fiber Optic Connectors</b>	<b>137</b>
9.4.1	Types of Fiber Optic Connectors	137
9.4.1.1	ST Connector	137
9.4.1.2	SC Connector	137
9.4.1.3	LC Connector	138
9.4.1.4	MT-RJ Connector	138
9.4.1.5	MTP/MPO Connector	138
9.4.1.6	FC Connector	139
9.4.1.7	FDDI Connector	139
9.4.1.8	SMA Connector	139

# 9. CABLE ACCESSORIES

<b>9.4</b>	<b>Fiber Optic Connectors (Continued)</b>	<b>140</b>
9.4.2	Considerations for Selecting Fiber Optic Connectors	140
9.4.2.1	Type and Construction of Connector	140
9.4.2.2	Mode of the Fiber	140
9.4.2.3	Fiber Cable Construction	141
9.4.3	Connector Termination Methods	141
9.4.3.1	No-Epoxy/No-Polish Connectors (Mechanical Splice Type)	142
9.4.3.2	Epoxy and Polish Connectors (Heat-Cured)	142
9.4.3.3	Epoxy and Polish Connectors (UV Cured)	142
9.4.2.4	Epoxy and Polish Connectors (Anaerobic)	142
<b>9.5</b>	<b>Cable Tray Systems</b>	<b>143</b>
9.5.1	Support Span	143
9.5.2	Working Load	143
9.5.3	Additional Load Considerations	143
9.5.4	Installation Environment	143
9.5.5	Nomenclature	144
9.5.6	Additional Information	144
<b>9.6</b>	<b>NEMA Plug and Receptacle Configurations</b>	<b>145</b>

## 9.1 COAXIAL CONNECTORS

Coaxial connectors should appear electrically as extensions to the cable; in other words, they should connect to the cable with as little disruption of the electrical signal as possible. Thus, a connector is usually specified by its nominal impedance and its allowable voltage standing wave ratio (VSWR). The nominal impedance of the connector indicates its basic match to the nominal impedance of the cable. The VSWR indicates the quality of the match.

### 9.1.1 Selection

Just as MIL-DTL-17 covers the main types of coaxial cables, MIL-PRF-39012 covers many popular types of coaxial connectors. It includes mating and overall dimensions, materials, performance and testing procedures for each connector.

In selecting a connector, users generally consider cable size, frequency range and coupling method.

Cable size determines the connector series as subminiature, miniature, medium or large.

Frequency range determines the upper frequency limit of the application. Connectors can be used at frequencies below this range but are not recommended at frequencies above this range where performance (especially VSWR) becomes degraded. Both BNC and TNC series connectors, for instance, can be used with miniature cable. The TNC connector, however, is usable to 11 GHz, while the BNC is limited to 4 GHz. (This is due to the difference between bayonet and screw couplings.) If the highest frequency of the application is 2 GHz, either connector can be used. If the highest frequency is 8 GHz, the TNC is the obvious choice.

Coupling method determines the procedure for joining two mating connectors. The three common types are bayonet, screw and snap-on. Often the coupling method is the main difference between two series of connectors. For example, a BNC connector uses bayonet coupling; a TNC connector is essentially the same, but with a threaded coupling.

### 9.1.2 BNC

By far, BNC connectors are the most common for miniature cables because of the easy connection/disconnection offered by their bayonet coupling. In most versions, BNC connectors are 50-ohm connectors rated to 4 GHz. 75-ohm, 4 GHz connectors are now available to meet the demand and usage of 75-ohm coax cable.

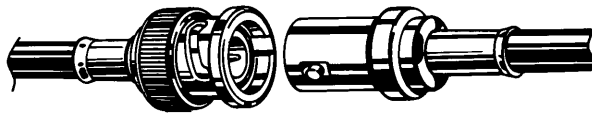

Figure 9.1—BNC Connectors

### 9.1.3 TNC

A TNC connector is virtually identical to a BNC connector, except it has a threaded rather than a bayonet coupling. The tight interface of the threads, especially when subjected to vibration, allows the connector to maintain a low VSWR up to 11 GHz with flexible cable and up to 15 GHz with semirigid cable.

### 9.1.4 SHV

For medium-size cables, SHV connectors are high-voltage connectors rated to 5,000 volts (rms). They have bayonet coupling but do not have a constant impedance. They were originally designed for high-energy physics applications.

### 9.1.5 SMA

Widely used in avionics, radar, military and high-performance test equipment applications, SMA connectors are the most popular type for subminiature cable and offer the highest performance in their class. They meet MIL-PRF-39012 requirements up to 12.4 GHz when used on flexible cable and up to 18 GHz on semirigid cable.

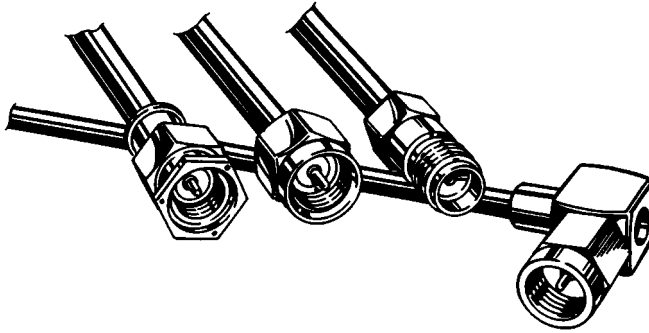

Figure 9.2—SMA Series Coax Connectors for Semirigid Cable

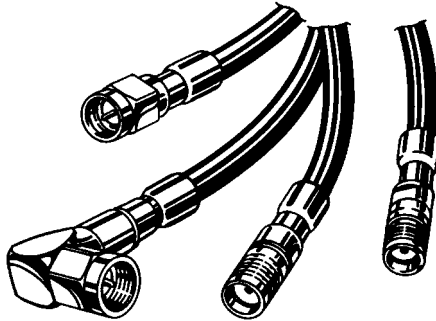

Figure 9.3—SMA Series Coax Connectors for Flexible Cable

### 9.1.6 UHF

The first coaxial connectors, designed in the 1930s, UHF connectors exhibit nonconstant impedance and a low upper-frequency limit of only 500 MHz, 2 GHz for the miniature version. Their main application is in cost-sensitive consumer applications.

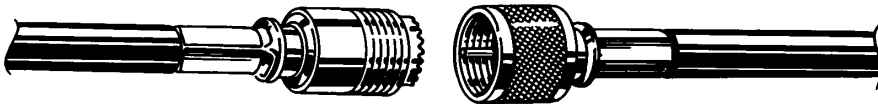

Figure 9.4—UHF Series Coax Connectors



### 9.1.7 N Series

These screw thread connectors were the first true RF connectors, developed during World War II to handle microwave frequencies up to 11 GHz. Despite the connector's age, it is still widely used, offering dual-crimp, low-cost commercial and 75-ohm versions in a variety of styles and materials. It is the standard coaxial connector for many coaxial cable-based local area networks, including Ethernet and other IEEE 802 networks using medium-size coaxial cable.

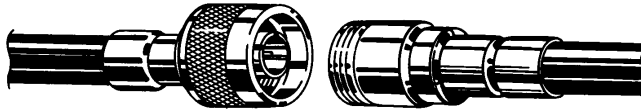

Figure 9.5—N Series Coax Connectors

### 9.1.8 F Series

The F type connectors are 75-ohm, screw threaded couplers for RG-59, RG-6, and RG-11 type coaxial cables and are the standard for cable television systems. The F type connector is simple to install, economical and meets the specifications of CATV/MATV systems. Most connectors are terminated to the cable by a single crimp on the attached ferrule.

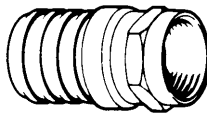

Figure 9.6—F Series Coax Connector

## 9.2 DATA CONNECTORS

### 9.2.1 RJ11 and RJ45 Modular

RJ11 and RJ45 modular plugs and jacks are widely used in communication applications. Some are designed for use with wires with solid conductors, others for stranded wire. The wiring configuration varies, depending on the wiring method selected for the system. The most used standards are ANSI/TIA-568-B (wiring methods “A” or “B”). With the locking tab down, the conductors are inserted into the rear of the plug in a specific pattern. The pins of the plug are numbered 1 through 8 as shown in [Figure 9.7](#).

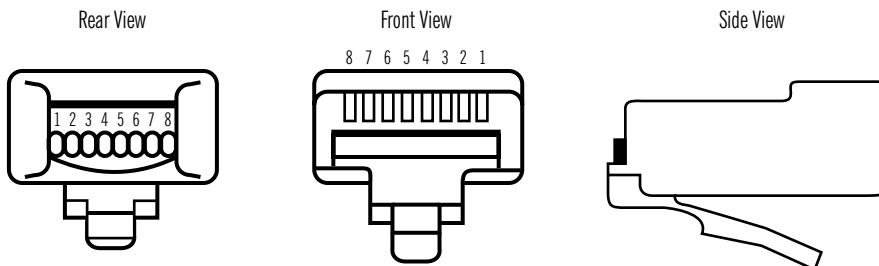

Figure 9.7—RJ45 (8 pin) Modular Plug

The individual pairs of 100-ohm UTP (unshielded twisted-pair) cabling are usually connected using one of the two pair assignments shown in [Figure 9.8](#).

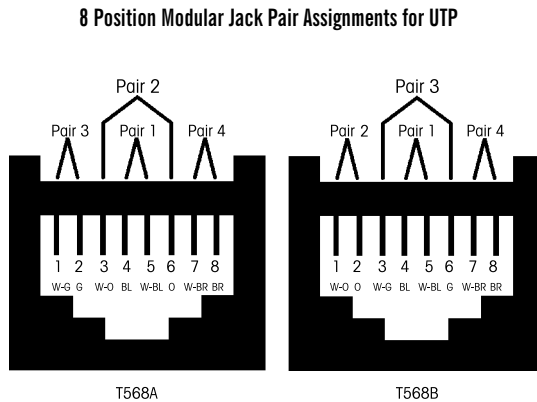

Figure 9.8—Front View of 8 Position Jack with Pair Assignments A (left) and B (right) for an RJ45 Modular Jack

## 9.3 POWER CONNECTORS

### 9.3.1 Selection

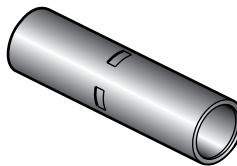

Figure 9.9—Typical Compression Connector

#### Compression Connectors

Compression connectors are designed for reliable and controllable electrical connections. Connectors must withstand a wide range of electrical and environmental conditions including current surges, temperatures, corrosion and vibration, for a wide variety of applications.

Copper compression connectors are normally manufactured from high-conductivity electrolytic copper. The connectors are normally tin-plated, lead-plated, or plated with a proprietary finish to provide corrosion resistance.

Aluminum compression connectors are usually manufactured from high-conductivity, high-purity wrought aluminum. They are designed with sufficient mass and are electro-tin plated to minimize corrosion due to galvanic action between dissimilar metals. The connector barrels are typically prefilled with oxide-inhibiting compound. Oxide-inhibiting compound usually contains homogeneously suspended metallic particles that penetrate the wire's oxides to establish continuity between the individual strands and the connector barrel for a low-resistance connection. Connector designs are engineered to match the cable size to provide the necessary physical strength requirements for reliable electrical performance.

#### Selection and Use

Copper compression connectors are recommended for use on copper conductors. Aluminum compression connectors are recommended for use on aluminum conductors. Dual-rated aluminum compression connectors may be used on both copper and aluminum conductors.

## Tooling

Tooling systems are essential for proper installation of a compression connector. Since connectors and dies are designed as a unit for specific wire sizes, only the recommended tools and dies should be used. Many aluminum and copper terminals and splices are marked with a die index number and are color-coded to identify the correct installation die. Dies marked with the matching die index number and color can be used to install the connector.

The tools include small plier types, full-cycle ratchet designs, hydraulically-powered heads and battery actuated tools. (See examples in [Figure 9.10.](#)) Some have permanent die grooves or adjustable dies, while others require a change of die sets or nest die for each connector size.

Manufacturers publish extensive tables of suitable connector, tool and die combinations to ensure a quality splice or termination. When properly installed, virtually all the air is removed leaving a tight homogeneous mass of connector and conductor.

## Industry Standards

Compression terminals ([Figure 9.11](#)), splices and tap connectors requiring third-party testing and approval are listed by Underwriters Laboratories, Inc. Many have also received CSA approval and are approved under SAE AS7928 (formerly MIL-T-7928) and other standards. All conform to applicable sections of the National Electrical Code.



Battery-operated crimping tool

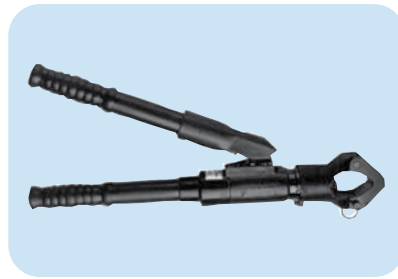

Hand-operated crimping tool

Figure 9.10—Typical Compression Tools

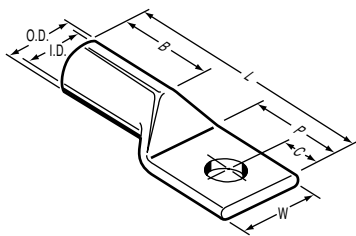

One-hole lug

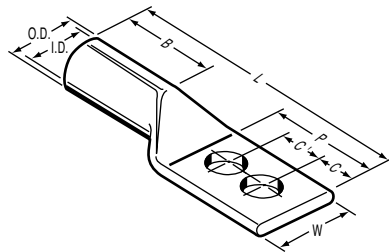

Two-hole lug

- B = Length of barrel
- C = Edge of tongue to center of stud hole
- C' = Stud hole spacing (two-hole lugs only)
- I.D. = Inner diameter
- L = Length of lug
- O.D. = Outer diameter
- P = Tongue length
- W = Tongue width

Figure 9.11—Typical Compression Terminals (Lugs)

9.3.2 Stud Sizes

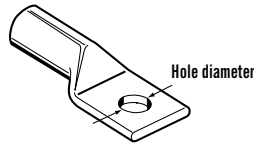

English			Metric		
Bolt Size	Bolt Diameter	Hole Diameter	Bolt Size	Bolt Diameter	Hole Diameter
	Inch	Inch		mm	mm
#2 ●	.086	.095	M2 ●	2.0	2.4
#4 ●	.112	.120	M2.5 ●	2.5	3.0
#5 ●	.125	.148	M3 ●	3.0	3.8
#6 ●	.138	.148	M3.5 ●	3.5	3.8
#8 ●	.164	.174	M4 ●	4.0	4.4
#10 ●	.190	.200	M5 ●	5.0	5.1
1/4" ●	.250	.265	M6 ●	6.0	6.7
5/16" ●	.3125	.328	M8 ●	8.0	8.3
3/8" ●	.375	.397	M10 ●	10.0	10.1
7/16" ●	.4375	.450	M10 ●	10.0	11.4
1/2" ●	.500	.515	M12 ●	12.0	13.1
5/8" ●	.625	.656	M16 ●	16.0	16.7
3/4" ●	.750	.781	M18 ●	18.0	19.8

Source: ISO 263 for English stud sizes and ISO 262 for metric stud sizes. **Note: Bolt illustrations not drawn to scale.**

Figure 9.12—Terminal Stud Size Chart in English and Metric Units

## 9.4 FIBER OPTIC CONNECTORS

Fiber optic connectors are used at the ends of optical fiber. They allow fiber optic equipment and patching connections to be made easily and quickly. The connectors mechanically couple and align the cores of fibers so that light can pass through with a minimum amount of attenuation (loss). Many types of fiber optic connectors are available. The main differences among the types of connectors are their dimensions, methods of mechanical coupling, the number of fibers they contain and the particular termination methods (including tooling, consumable items and training) required to install them.

### 9.4.1 Types of Fiber Optic Connectors

The larger standard-size fiber connectors, such as the ST and SC, have been around for many years and are still the most widely used. There are several varieties of newer small form factor (SFF) connectors that are much smaller than the ST and SC. Because of their small size, they allow a higher fiber port density on optical equipment and patch panels. Two common SFF connector types are the LC and the MT-RJ. For higher multi-fiber terminations (up to 12 fibers) there is the MTP/MPO connector. It is usually used with ribbon cable for high-density backbone, cross-connect and breakout applications.

#### 9.4.1.1 ST Connector

The standard-size ST connector was one of the first connector types widely implemented in fiber optic networking applications. Originally developed by AT&T, it stands for Straight Tip connector. ST connections use a 2.5 mm ferrule with a round plastic or metal body that holds a single fiber. The connector has a bayonet style “twist-on/twist-off” mechanism. The ST is still very popular for building applications but it is slowly being replaced by the SC and the smaller, denser, small form factor (SFF) connectors.



Figure 9.13—ST Connector

#### 9.4.1.2 SC Connector

The standard-size SC connector also has a round 2.5 mm ferrule to hold a single fiber. It is non-optically disconnecting and has a “keyed” insertion for performance reliability and to prevent tip rotation. The SC utilizes a push-on/pull-off mating mechanism, which is easier to use than the twist-style ST connector when in tight spaces. The connector body of an SC connector is square, and two SC connectors are often held together with a plastic clip making this a “duplex” connection. It was developed in Japan by NTT (the Japanese telecommunications company) and is believed to be an abbreviation for Subscriber Connector. This is the recommended standard-size fiber connector for enterprise cabling installations.



Figure 9.14—SC Connector

### 9.4.1.3 LC Connector

The LC connector is the most commonly used small form factor (SFF) connector. It was developed by Lucent Technologies and it stands for Lucent Connector. It utilizes a push-pull mechanism, similar to the SC, and the connector body resembles the square shape of SC connectors but it is much smaller. Each connector holds one fiber. Two LC connectors are normally held together in a duplex configuration with a plastic clip. The joined duplex LC connector only takes as much space as one SC connector. The ferrule of an LC connector is 1.25 mm.

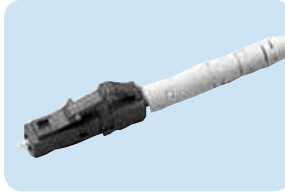

Figure 9.15—LC Connector

### 9.4.1.4 MT-RJ Connector

The MT-RJ is another small form factor (SFF) connector. It was developed by AMP/Tyco and Corning and MT-RJ stands for Mechanical Transfer-Registered Jack. The MT-RJ connector closely resembles an RJ-style modular plug and terminates two fibers in a single ferrule so it is always “duplex.” This connector fits an adapter with the same footprint of a standard single-fiber connector. The connector locks into place with a tab (just like a modular RJ-style plug).



Figure 9.16—MT-RJ Connectors

### 9.4.1.5 MTP/MPO Connector

The MTP is a high-density multifiber optical connector. It is a trademark of US Conec and is an improvement on the original MPO (multi-fiber push-on) connector designed by NTT. The MTP connector contains up to twelve optical fibers within a single ferrule and is available in both multimode and single-mode versions. This connector is used with fiber ribbon cable to achieve very high density. The connection is held in place by a push-on/pull-off latch and has a pair of metal guide pins that protrude from the front of the connector for alignment. The MTP connector is often used on both ends of preterminated cable assemblies to facilitate the quick and easy interconnection of preconnectorized patch panels. In addition, it is used at one end of cable assemblies that “break out” multi-fiber cables into separate single fiber connectors at the other end. MTP/MPO applications include horizontal zone cabling systems as well as high-density backbones and cross-connects used in large buildings, data centers, disaster recovery and industrial operations.



Figure 9.17—MTP/MPO Connector

### 9.4.1.6 FC Connector

The FC connector has a 2.5 mm ferrule tip with a threaded screw-on mechanism. It is keyed to prevent tip rotation and damage to mated fiber. These connectors are typically used for single-mode applications but multimode connectors are available. Not as popular as it once was, it is slowly being replaced by SC and LC connectors.

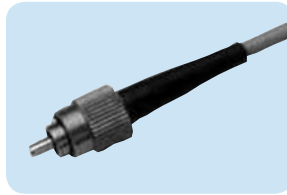

Figure 9.18—FC Connector

### 9.4.1.7 FDDI Connector

FDDI stands for fiber distributed data interface. It is actually a fiber-based network access method based on the Token Ring protocol and utilizes two fiber rings. One is the primary and one is for backup. The termination on the fiber optic cable itself is called an FDDI connector also known as an MIC (media interface connector) connector. It contains two ferrules in a large, bulky plastic housing that uses a squeeze-tab retention mechanism. The FDDI connector is designed to mate to its specific network. It is generally used to connect to equipment from a wall outlet while the rest of the network will have ST, SC or other SFF connectors. The FDDI connector has a keying system to prevent connections of incompatible network nodes. There are four receptacle keys: A, B, M and S.



Figure 9.19—FDDI Connector

### 9.4.1.8 SMA Connector

This connector was designed by Amphenol and stands for “Subminiature A.” It was originally designed for the military and was in use before the ST connector. It was the dominant connector in data and closed-circuit video applications. There are two types used: SMA 905, which has a ferrule that is the same diameter from the base to the tip, and SMA 906, which has an indented (smaller diameter) section on the tip side of the ferrule. Most SMA 906 type connectors come with a plastic ring on the tip so they can be used as a SMA 905 connector. While it is still found in predominantly military and industrial applications, the use of the SMA connector is diminishing. It is rarely used in building network applications.

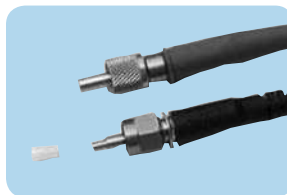

Figure 9.20—SMA Connector

### 9.4.2 Considerations for Selecting Fiber Optic Connectors

When selecting fiber optic connectors, the following must be taken into consideration:

- Type and construction of connector (SC, ST, LC, FC, MT-RJ, MTP etc.)
- Mode of fiber being connectorized (single-mode or multimode)
- Construction of fiber (tight buffer, loose tube, breakout, jumper cordage, etc.)
- Termination method (heat cure, UV cure, no epoxy/no polish, anaerobic, etc.)

#### 9.4.2.1—Type and Construction of Connector

Choosing the right fiber connector means selecting the proper form factor, the specific style and in some cases the type of material used. The three most common form factors (sizes) are “standard” size, small form factor (SFF) and the high-density multi-fiber type connector.

Some considerations are:

- For new installations, SC is the recommended standard-size connector followed by the ST in popularity (other types are available).
- LCs are the most common small form factor (SFF) connector (other types, such as the MT-RJ connector, are also available).
- The MPO/MTP type connector is used for high-density fiber applications usually with ribbon fiber.
- When adding fiber and connectors to an existing facility, one should consider using the same type of connectors throughout the facility.
- Many projects have a written specification that defines the particular type of fiber connector required.
- If most opto-electronic equipment in a facility has predominantly one connector type, it might make sense to use the same type of connector on the fiber infrastructure and distribution cabinets.
- Fiber patch cords with different connector types at each end can be used where the opto-electronic equipment connector does not match the connector on the fiber distribution equipment.

The type of material used in the tip (ferrule) of the connector is also important. These are commonly used materials:

- Ceramic — Connector tips made from ceramic are preferred because ceramic closely matches the thermal characteristics of glass. It is a hard, durable material that does not wear down even after a high number of reconnections; however, it is more expensive than other materials.
- Composite (polymer) — Connectors with composite tips are not as durable as those made from ceramic or stainless steel but offer a cost-effective solution and are suitable for many applications where a high number of reconnections are not anticipated. Polymer materials have the advantage of a lower cost without sacrificing performance.
- Stainless steel — Stainless steel tips offer durability. Connectors with stainless steel ferrules (when compared to ceramic or composite), however, have higher typical insertion loss, generate more debris during re-mating and do not perform well during thermal cycling or vibration testing.

#### 9.4.2.2—Mode of the Fiber

The mode of the fiber is important when selecting a fiber connector. Fibers are either multimode or single-mode.

- Multimode — The most common size for multimode fiber is 62.5/125  $\mu\text{m}$ . This indicates a core diameter of 62.5  $\mu\text{m}$  surrounded by a cladding layer of glass making the overall diameter of the fiber 125  $\mu\text{m}$ . Another type of multimode fiber gaining popularity is 50/125  $\mu\text{m}$ . Note that the core size of the 50  $\mu\text{m}$  fiber is smaller than the 62.5  $\mu\text{m}$  fiber but provides a greater bandwidth. However, it has the same overall diameter of 125  $\mu\text{m}$  as the 62.5  $\mu\text{m}$  core because cladding layer of glass is thicker.
- Single-mode — The typical fiber size is 8/125  $\mu\text{m}$  which indicates a core diameter of 8  $\mu\text{m}$  surrounded by a cladding layer of glass making the overall diameter of the fiber 125  $\mu\text{m}$ . Note that the overall fiber diameter, at 125  $\mu\text{m}$ , is the same as for multimode.

Even though the overall fiber diameter size (core plus cladding) may be the same between single-mode and multimode fibers there is typically a different connector required for each within the same type (i.e., SC single-mode or SC multimode connector). Single-mode connectors must be manufactured to more precise tolerances; therefore, they are generally more expensive. This is because the proper alignment of the 8  $\mu\text{m}$  single-mode core is more critical than on the larger 50 or 62.5  $\mu\text{m}$  multimode cores.



### 9.4.2.3—Fiber Cable Construction

The construction of the fiber cable needs to be considered when selecting fiber optic connectors. It is important that the proper cable be selected based on the environment and application needed. Primary construction types are tight buffered, loose tube (loose buffer), ribbon cable, fan-out/breakout cable and jumper cordage.

- **Tight-buffered cable (Tight buffered multi-fiber distribution cable)** — This type of fiber is used mainly indoors; however, there are now tight-buffered outdoor versions available. Tight-buffered cable has a “buffer” layer of plastic coating extruded onto the fiber. It is in direct contact with the fiber and surrounds it bringing the O.D. of the fiber up to 900  $\mu\text{m}$ . Connectors can be directly installed on the ends of 900  $\mu\text{m}$  tight-buffered fibers without the use of a fan-out or breakout kit. Multi-fiber building cable has multiple tight-buffered fibers under a common jacket. It is available in both single-mode and multimode versions.
- **Loose tube (loose buffer) cable** — Loose tube cables are used for outdoor applications and contain multiple bare fibers that float freely within larger buffer tubes. They may contain multiple small tubes, called subunits, that contain several fibers each or there may be one “central” tube that contains all the fibers in the cable. These cables are water-blocked utilizing gel and/or dry water-swellaable tapes or yarns within and around the buffer tube(s) inside the cable. They come in various constructions depending on whether they will be installed aerially, in duct or in direct buried applications. Loose tube cables require a buffer tube fan-out or breakout kit in order to connectorize the fibers. Choose a connector that matches the breakout kit subunit type for a proper fit. Loose-tube cable is available in single-mode or multimode versions. Traditionally, most loose-tube cable was not UL Listed for indoor use so it had to be terminated or transitioned to an inside-rated cable within 50 ft. of the building entrance point if run exposed. There are now versions available that are indoor/outdoor rated making it allowable to extend the cable further than 50 ft. from the building entrance point within buildings.
- **Ribbon cable** — A type of cable construction that provides the highest fiber density in the most compact cable size. Inside the cable the fibers are typically laid out in rows of 12 fibers each, one row on top of the other. It is ideal for mass-fusion splicing and for use with multi-fiber connectors such as the MTP/MPO. Ribbon fiber cable has become very popular as the cable of choice for deployment in campus, building, and data-center backbones where high-density fiber counts are needed. It is available in both single-mode and multimode versions and in indoor and outdoor constructions.
- **Fan-out/breakout cable** — Each fiber in a fan-out/breakout cable is jacketed and protected with strength members. In effect, each fiber is a simplex jumper cord (patch cable). A connector can be installed directly on each jacketed fiber and the connectorized fibers can be patched directly into electronic equipment or patch panels etc. These cables can be single-mode or multimode and are available in both indoor and outdoor versions. Connectors must be selected that fit the O.D. of the jacket on the cable.
- **Jumper cordage (patch cable)** — Jumper cordage is divided into four construction types: simplex, zipcord duplex, dual subunit duplex, and round duplex. Simplex, zipcord, and dual subunit cordages can be directly connectorized. Round duplex usually requires a breakout kit.

### 9.4.3 Connector Termination Methods

The final step in choosing a fiber connector, once the connector type, fiber mode and cable construction are known, is to select the desired termination method of the connector. Within the same connector types (ST, SC, LC, etc.), there are different termination methods to choose from based on the connector manufacturer’s design and the particular methods used to to prepare, connect, hold and terminate the fibers within the connector itself. Each type of connector has its own procedures and requirements for the tools, accessories and in some cases consumable items, necessary for proper installation. These vary from manufacturer to manufacturer and even within connector types from the same manufacturer.

With technical specifications being equal, the termination method chosen usually comes down to a matter of cost based on the following considerations:

- Is a specific termination method specified?
- Is the installer already equipped with the tool kits and accessories needed for use with a particular type of connector termination method?
- How many connectors are being installed?
- What is the training and experience level of the installer?
- What are the material costs? (connector itself, tooling etc.)
- What are the consumable costs? (adhesive/epoxy, polishing films, etc.)
- What is the cost of labor? (curing, polishing, setup and tear-down)

The following explains the most common termination methods:

### 9.4.3.1—No Epoxy/No Polish Connectors (Mechanical Splice Type)

This type of connector has become very popular. It is a connector with a polished fiber already factory-installed in the tip along with a mechanical splice type alignment system to facilitate attaching the connector to the end of a fiber. Single-mode, 50/125  $\mu\text{m}$  multimode, laser-optimized 50/125  $\mu\text{m}$  multimode and 62.5 /125  $\mu\text{m}$  multimode versions are available for each connector.

When taking into account the material, labor and consumables costs of termination, these type connectors are often the most cost-effective solution.

- No epoxy or polishing
- No consumables and few tools needed
- No power source required
- Minimal setup required
- Connectors cost more
- Faster installation
- Reduced labor cost

### 9.4.3.2—Epoxy and Polish Connectors (Heat-Cured)

The fiber is secured in the connector using epoxy. This type of connector is a cost-effective way to make cable assemblies or to install in locations where a large number of fibers are terminated at one time.

- Heat-cured in an oven
- Batch termination
- Low connector cost
- Consumables required (epoxy and polishing paper, etc.)
- Requires polishing
- Longer installation time than no epoxy/no polish

### 9.4.3.3—Epoxy and Polish Connectors (UV Cured)

This connector uses UV light to cure the epoxy. Usually a more cost-effective solution than heat-cured connectors.

- Epoxy cured by UV lamp — no heat generated
- Lower connector cost
- Lower consumables cost
- Requires polishing (easier polish than heat-cure)
- Faster cure and overall installation time than heat-cured connectors
- Higher yields/less scrap

### 9.4.3.4—Epoxy and Polish Connectors (Anaerobic)

No ovens or UV lamps are needed for curing. An adhesive is injected into the connector ferrule and it will not harden until mixed with a curing agent. The bare fiber is dipped into a primer and then pushed through the ferrule. This causes the primer and adhesive to mix and curing occurs.

- No oven or lamp needed
- No electrical source required
- Requires polishing
- Faster installation time than heat-cured

---

## 9.5 CABLE TRAY SYSTEMS

---

### 9.5.1 Support Span

The support span length is an important consideration as it affects the strength of the system and the length of the straight sections required. Tray types typically used for various span lengths include:

- Short span: 6- to 8-foot support spacing (use 12-foot sections)
- Intermediate span: 8- to 12-foot support spacing (use 12-foot sections)
- Long span: 16- to 20-foot support spacing (use 20-foot sections)
- Extra long span: over 20-foot to 30-foot support spacing (use 24- or 30-foot sections).

### 9.5.2 Working Load

The working load depends on tray size (width, loading depth and strength). Considerations include:

- Types and numbers of cables to support (total cable load in lb. per linear foot (lb./ft.))
- Power cables in a single layer – width is key issue (refer to applicable electrical code)
- Low-voltage cables in a stacked configuration – key issues are loading depth and width (refer to applicable electrical code).

### 9.5.3 Additional Load Considerations

- 200-lb. concentrated load – industrial installations
- Ice, wind, snow loads – outdoor installations

### 9.5.4. Installation Environment

Tray material and finish have a significant impact on tray performance in any given environment. Typical tray types used in various environments are shown below.

- Indoor dry (institutional, office, commercial, light industrial): aluminum, pregalvanized steel
- Indoor industrial (automotive, pulp and paper, power plants): aluminum, pregalvanized steel, possibly hot-dipped galvanized after fabrication (HDGAF)
- Outdoor industrial (petrochemical, automotive, power plants): aluminum, hot-dipped galvanized after fabrication (HDGAF)
- Outdoor marine (off shore platforms): aluminum, stainless steel, fiberglass
- Special (petrochemical, pulp and paper, environmental air): contact manufacturer

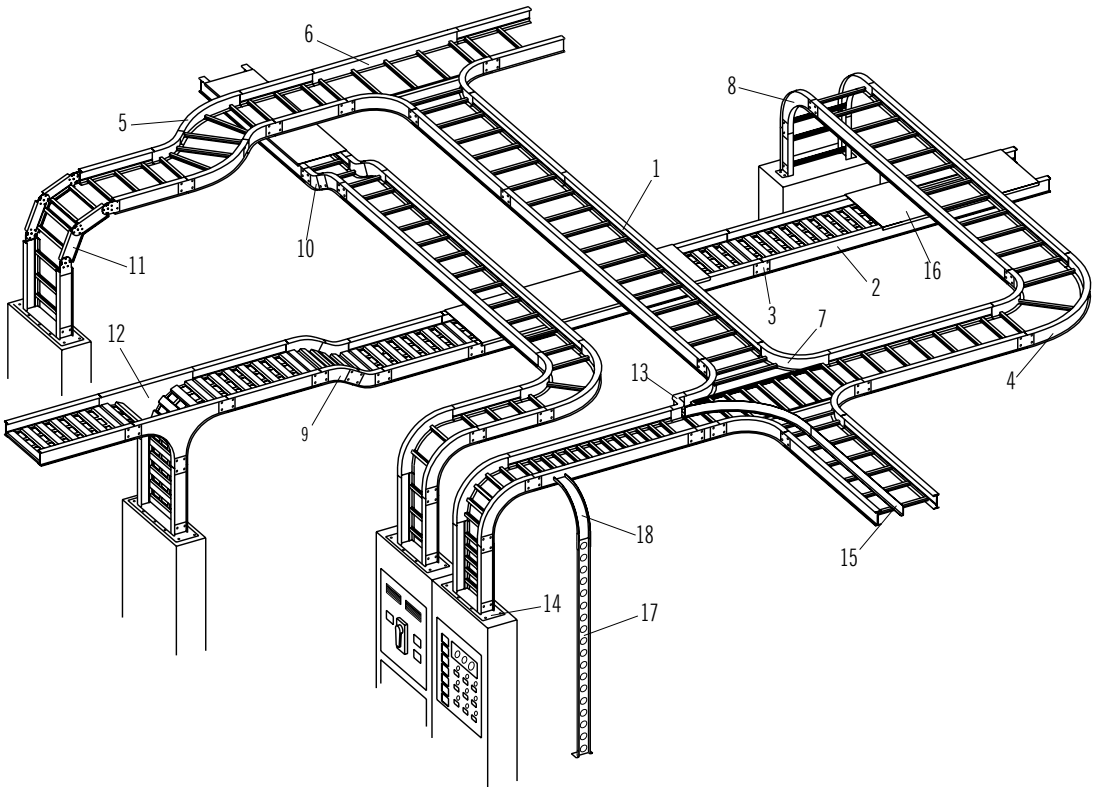

Figure 9.21—Cable Tray System

### 9.5.5 Nomenclature

The following items are keyed by number to the parts illustrated in **Figure 9.21**:









- |                                                                 |                                                             |
|-----------------------------------------------------------------|-------------------------------------------------------------|
| 1. Ladder-type cable tray                                       | 10. 30 degrees vertical inside bend, ladder-type cable tray |
| 2. Ventilated trough-type cable tray                            | 11. Vertical bend segment (VBS)                             |
| 3. Straight splice plate                                        | 12. Vertical tee down, ventilated trough-type cable tray    |
| 4. 90 degrees horizontal bend, ladder-type cable tray           | 13. Left-hand reducer, ladder type cable tray               |
| 5. 45 degrees horizontal bend, ladder-type cable tray           | 14. Frame type box connector                                |
| 6. Horizontal tee, ladder-type cable tray                       | 15. Barrier strip straight section                          |
| 7. Horizontal cross, ladder-type cable tray                     | 16. Solid flanged tray cover                                |
| 8. 90 degrees vertical outside bend, ladder-type cable tray     | 17. Ventilated channel straight section                     |
| 9. 45 degrees vertical outside bend, ventilated-type cable tray | 18. Channel cable tray, 90 degrees vertical outside bend    |

### 9.5.6 Additional Information









Additional information on cable tray systems is contained in NEMA VE-1 “Metal Cable Tray Systems,” NEMA VE-2 “Cable Tray Installation Guidelines,” Article 392 of the National Electrical Code (NFPA 70) and on the Cable Tray Institute Web site at [www.cabletrays.com](http://www.cabletrays.com).

## 9.6 NEMA PLUG AND RECEPTACLE CONFIGURATIONS









Table 9.1—NEMA Non-Locking Plug Configurations

15 AMP								
2-Pole 2-Wire	2-Pole, 3-Wire, Grounding			3-Pole 3-Wire	3-Pole, 4-Wire, Grounding		4-Wire	
1-Phase 125 V	1-Phase 125 V	1-Phase 250 V	1-Phase 277 V	3-Phase 250 V	1-Phase 125/250 V	3-Phase 250 V	3-Phase 120/208 V	
								
1-15	5-15	6-15	7-15	11-15	14-15	15-15	18-15	

20 AMP								
2-Pole 2-Wire	2-Pole, 3-Wire, Grounding			3-Pole, 3-Wire		3-Pole, 4-Wire, Grounding		4-Wire
1-Phase 250 V	1-Phase 125 V	1-Phase 250 V	1-Phase 277 V	1-Phase 125/250 V	3-Phase 250 V	1-Phase 125/250 V	3-Phase 250 V	3-Phase 250 V 120/208 V
								
2-20	5-20	6-20	7-20	10-20	11-20	14-20	15-20	18-20

30 AMP								
2-Pole 2-Wire	2-Pole, 3-Wire, Grounding			3-Pole, 3-Wire		3-Pole, 4-Wire, Grounding		4-Wire
1-Phase 250 V	1-Phase 125 V	1-Phase 250 V	1-Phase 277 V	1-Phase 125/250 V	3-Phase 250 V	1-Phase 125/250 V	3-Phase 250 V	3-Phase 250 V 120/208 V
								
2-30	5-30	6-30	7-30	10-30	11-30	14-30	15-30	18-30

Continued >>

Table 9.1—NEMA Non-Locking Plug Configurations (Continued)

50 AMP							
2-Pole, 3-Wire, Grounding			3-Pole, 3-Wire		3-Pole, 4-Wire, Grounding		4-Wire
1-Phase 125 V	1-Phase 250 V	1-Phase 277 V	1-Phase 125/250 V	3-Phase 250 V	1-Phase 125/250 V	3-Phase 250 V	3-Phase 120/208 V
5-50	6-50	7-50	10-50	11-50	14-50	15-50	18-50

60 AMP		
3-Pole, 4-Wire, Grounding		4-Wire
1-Phase 125/250 V	3-Phase 250 V	3-Phase 120/208 V
14-60	15-60	18-60





































Note: Receptacle configurations are a mirror image of the plug configurations shown.

Table 9.2—NEMA Locking Plug Configurations

15 AMP			
2-Pole 2-Wire	2-Pole, 3-Wire, Grounding		
1-Phase 125 V	1-Phase 125 V	1-Phase 250 V	1-Phase 277 V
L1-15	L5-15	L6-15	L7-15

Continued >>

Table 9.2—NEMA Locking Plug Configurations (Continued)

20 AMP									
2-Pole 2-Wire	2-Pole, 3-Wire, Grounding					3-Pole, 3-Wire			
1-Phase 250 V	1-Phase 125 V	1-Phase 250 V	1-Phase 277 V	1-Phase 480 V	1-Phase 600 V	1-Phase 125/250 V	3-Phase 250 V	3-Phase 480 V	
									
2-20	5-20	6-20	7-20	10-20	11-20	14-20	15-20	18-20	
20 AMP									
3-Pole, 4-Wire, Grounding			4-Pole, 4-Wire			4-Pole, 5-Wire, Grounding			
1-Phase 125/250 V	3-Phase 250 V	3-Phase 480 V	3-Phase 120/208 V	3-Phase 277/480 V	3-Phase 347/600 V	3-Phase 120/208 V	3-Phase 277/480 V	3-Phase 347/600 V	
									
L14-20	L15-20	L16-20	L18-20	L19-20	L20-20	L21-20	L22-20	L23-20	
30 AMP									
2-Pole, 3-Wire, Grounding					3-Pole, 3-Wire				
1-Phase 125 V	1-Phase 250 V	1-Phase 277 V	1-Phase 480 V	1-Phase 600 V	1-Phase 125/250 V	3-Phase 250 V	3-Phase 480 V	3-Phase 600 V	
									
L5-30	L6-30	L7-30	L8-30	L9-30	L10-30	L11-30	L12-30	L13-30	
30 AMP									
3-Pole, 4-Wire, Grounding				4-Pole, 4-Wire			4-Pole, 5-Wire, Grounding		
1-Phase 125/250 V	3-Phase 250 V	3-Phase 480 V	3-Phase 600 V	3-Phase 120/208 V	3-Phase 120/208 V	3-Phase 277/480 V	3-Phase 120/208V	3-Phase 277/480 V	3-Phase 347/600 V
									
L14-30	L15-30	L16-30	L17-30	L18-30	L19-30	L20-30	L21-30	L22-30	L23-30

Note: Receptacle configurations are a mirror image of the plug configurations shown.





# 10. PACKAGING OF WIRE AND CABLE

<b>10.1</b>	<b>Reel Size</b>	<b>150</b>
	10.1.1 Reel Terminology	150
	10.1.2 Minimum Drum Diameter	150
	10.1.3 Capacities (ft.) and Dimensions of Shipping Reels	152
<b>10.2</b>	<b>Reel Handling</b>	<b>157</b>
	10.2.1 Storage and Shipment	157
	10.2.2 Moving and Lifting	157

## 10.1 REEL SIZE

Selection of proper reel (spool) size depends on the length and overall diameter (O.D.) of the cable or wire to be rewound. A reel not matched to the weight of the cable wound on it may be damaged during shipment.

All wire and cable has a minimum safe bending radius. If cable is subjected to bends sharper than the minimum radius, damage to the material is likely. The minimum drum (hub) diameters given in [Section 10.1.2](#) should be observed.

### 10.1.1 Reel Terminology

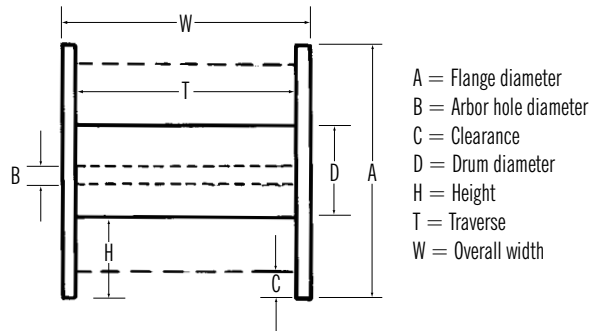

Figure 10.1—Reel Terminology

### 10.1.2 Minimum Drum Diameter

Table 10.1—Minimum Drum Diameter for Wire and Cable

Type of Cable	Minimum Drum Diameter as a Multiple of Outside Diameter of Cable
<b>A. Single- and multiple-conductor nonmetallic-covered cable</b>	
1. Nonshielded and wire shielded, including cable with concentric wires	10
a. 0–2,000 volts	
b. Over 2,000 volts	
(1) Nonjacketed with concentric wires	12
(2) All others	14
2. Tape shielded	
a. Helically applied	14
b. Longitudinally applied flat tape	20
c. Longitudinally applied corrugated tape	14
<b>B. Single- and multiple-conductor metallic-covered cable</b>	
1. Tubular metallic sheathed	
a. Lead	14
b. Aluminum	25
(1) Outside diameter – 1.750 in. and less	
(2) Outside diameter – 1.751 in. and larger	30
2. Wire armored	16
3. Flat tape armored	16
4. Corrugated metallic sheath	14
5. Interlocked armor	14

Continued >>

Table 10.1 Minimum Drum Diameter for Wire and Cable (Continued)

Type of Cable	Minimum Drum Diameter as a Multiple of Outside Diameter of Cable
C. Multiple single conductors cabled together without common covering, including self-supporting cables – the circumscribing overall diameter shall be multiplied by the factor given in item A or B and then by the reduction factor of 0.75.	
D. Combinations – For combinations of the types described in items A, B and C, the highest factor for any component type shall be used.	
E. Single- and multiple-conductor cable in coilable nonmetallic duct	
Outside diameter of duct, inches – 0.0–0.50	26
0.51–1.00	24
1.01–1.25	22
1.26–1.50	21
Over 1.50	19
F. Fiber optic cables (in no case less than 12 inches)	20*
G. Bare conductor	20

## Notes to Table:

1. When metallic-sheathed cables are covered only by a thermosetting or thermoplastic jacket, the outside diameter is the diameter over the metallic sheath itself. In all other cases, the outside diameter is the diameter outside of all the material on the cable in the state in which it is to be wound upon the reel.
2. For “flat-twin” cables (where the cable is placed upon the reel with its flat side against the drum), the minor outside diameter shall be multiplied by the appropriate factor to determine the minimum drum diameter.
3. The multiplying factors given for item E refer to the outside diameter of the duct.

\* Some manufacturers recommend 30.

Sources: NEMA WC 26 (EEMAC 201) Binational Wire and Cable Packaging Standard

10.1.3 Capacities (ft.) and Dimensions of Shipping Reels

Table 10.2—Capacities (ft.) of Typical Shipping Reels per NEMA WC 26

Flange Dia. (in.)	16	16	20	24	24	24	28	30	32	36
Traverse (in.)	10	12	12	12	12	16	18	18	24	24
Drum Dia. (in.)	12	6	8	10	12	10	12	12	16	16
Clearance (in.)	1	1	1	1	1	1	1	2	2	2
Cable O.D. (in.)	0.10	12,576	20,436	30,182	26,724	40,243				
	0.15	5,589	9,083	13,414	11,877	17,886	27,877	27,877	36,890	
	0.20	3,144	5,109	7,546	6,681	10,061	15,681	15,681	20,750	30,182
	0.25	2,012	3,270	4,829	4,276	6,439	10,036	10,036	13,280	19,317
	0.30	1,397	2,271	3,354	2,969	4,471	6,969	6,969	9,222	13,414
	0.35	1,027	1,668	2,464	2,182	3,285	5,120	5,120	6,776	9,855
	0.40		1,277	1,886	1,670	2,515	3,920	3,920	5,188	7,546
	0.45		1,009	1,490	1,320	1,987	3,097	3,097	4,099	5,962
	0.50		817	1,207	1,069	1,610	2,509	2,509	3,320	4,829
	0.55			998	883	1,330	2,073	2,073	2,744	3,991
	0.60			838	742	1,118	1,742	1,742	2,306	3,354
	0.65				633		1,485	1,485	1,965	2,858
	0.70				545		1,280	1,280	1,694	2,464
	0.75				475		1,115	1,115	1,476	2,146
	0.80								1,297	1,886
	0.85								1,149	1,671
	0.90								1,025	1,490
	0.95								920	1,338
	1.00								830	1,207
	1.05									
1.10										
1.15										
1.20										
1.25										
1.30										
1.35										
1.40										
1.45										
1.50										
1.55										
1.60										
1.65										
1.70										

The following formula from NEMA WC 26 can be used to calculate approximate cable capacity per reel:

$$\text{Footage} = \frac{0.262 \times T \times (H-C) \times (D+H-C)}{(\text{Wire O.D.})^2}$$

40	42	48	54	60	66	72	78	84	90	96
30	26	36	32	28	36	36	48	54	54	54
16	24	24	24	28	36	36	42	48	48	56
2	2	2	3	3	3	3	3	3	3	3
32,698	23,651									
22,707	16,424	35,632	40,243	43,445						
16,682	12,067	26,179	29,566	31,919	44,350					
12,773	9,239	20,043	22,637	24,438	33,955	45,097				
10,092	7,300	15,836	17,886	19,309	26,829	35,632				
8,174	5,913	12,828	14,488	15,640	21,731	28,862	43,010			
6,756	4,887	10,601	11,973	12,926	17,960	23,853	35,545	44,198		
5,677	4,106	8,908	10,061	10,861	15,091	20,043	29,868	37,139	46,688	48,771
4,837	3,499	7,590	8,573	9,255	12,859	17,078	25,450	31,645	39,782	41,557
4,171	3,017	6,545	7,392	7,980	11,087	14,725	21,944	27,285	34,302	35,832
3,633	2,628	5,701	6,439	6,951	9,658	12,828	19,116	23,769	29,881	31,214
3,193	2,310	5,011	5,659	6,110	8,489	11,274	16,801	20,890	26,262	27,434
2,829	2,046	4,439	5,013	5,412	7,519	9,987	14,882	18,505	23,263	24,301
2,523	1,825	3,959	4,471	4,827	6,707	8,908	13,275	16,506	20,750	21,676
2,264	1,638	3,553	4,013	4,333	6,020	7,995	11,914	14,814	18,624	19,454
2,044	1,478	3,207	3,622	3,910	5,433	7,215	10,752	13,370	16,808	17,558
	1,341	2,909	3,285	3,547	4,928	6,545	9,753	12,127	15,245	15,925
	1,222	2,650	2,993	3,231	4,490	5,963	8,886	11,049	13,891	14,510
	1,118	2,425	2,739	2,957	4,108	5,456	8,130	10,110	12,709	13,276
	1,027	2,227	2,515	2,715	3,773	5,011	7,467	9,285	11,672	12,193
	946	2,052	2,318	2,502	3,477	4,618	6,882	8,557	10,757	11,237
	875	1,898	2,143	2,314	3,215	4,270	6,362	7,911	9,945	10,389
	811	1,760	1,987	2,145	2,981	3,959	5,900	7,336	9,222	9,634
	754	1,636	1,848	1,995	2,772	3,681	5,486	6,821	8,575	8,958
	703	1,525	1,723	1,860	2,584	3,432	5,114	6,359	7,994	8,351
	657	1,425	1,610	1,738	2,415	3,207	4,779	5,942	7,470	7,803
				1,628	2,261	3,003	4,476	5,565	6,996	7,308
				1,527	2,122	2,819	4,200	5,223	6,566	6,858
				1,436	1,996	2,650	3,949	4,911	6,174	6,449
				1,353	1,880	2,497	3,721	4,626	5,816	6,075

Continued >>

Table 10.2—Capacities (ft.) of Typical Shipping Reels per NEMA WC 26 (Continued)

Flange Dia. (in.)	16	16	20	24	24	24	28	30	32	36
Traverse (in.)	10	12	12	12	12	16	18	18	24	24
Drum Dia. (in.)	12	6	8	10	12	10	12	12	16	16
Clearance (in.)	1	1	1	1	1	1	1	2	2	2
Cable O.D. (in.)	1.75									
	1.80									
	1.85									
	1.90									
	1.95									
	2.00									
	2.05									
	2.10									
	2.15									
	2.20									
	2.25									
	2.30									
	2.35									
	2.40									
	2.45									
	2.50									
	2.55									
	2.60									
	2.65									
	2.70									
	2.75									
	2.80									
	2.85									
	2.90									
	2.95									
	3.00									
	3.05									
	3.10									
	3.15									
	3.20									
3.25										
3.30										
3.35										
3.40										
3.45										
3.50										

The following formula from NEMA WC 26 can be used to calculate approximate cable capacity per reel:

$$\text{Footage} = \frac{0.262 \times T \times (H-C) \times (D+H-C)}{(\text{Wire O.D.})^2}$$

10. Packaging of Wire and Cable

40	42	48	54	60	66	72	78	84	90	96
30	26	36	32	28	36	36	48	54	54	54
16	24	24	24	28	36	36	42	48	48	56
2	2	2	3	3	3	3	3	3	3	3
				1,277	1,774	2,356	3,511	4,366	5,488	5,733
					1,677	2,227	3,319	4,127	5,188	5,419
					1,587	2,108	3,142	3,906	4,911	5,130
					1,505	1,999	2,979	3,704	4,656	4,864
					1,429	1,898	2,828	3,516	4,420	4,617
					1,358	1,804	2,688	3,342	4,202	4,389
					1,293	1,717	2,559	3,181	3,999	4,178
					1,232	1,636	2,438	3,032	3,811	3,981
					1,175	1,561	2,326	2,892	3,636	3,798
					1,122	1,491	2,222	2,762	3,473	3,628
							2,124	2,641	3,320	3,468
							2,033	2,527	3,177	3,319
							1,947	2,421	3,044	3,179
							1,867	2,321	2,918	3,048
							1,791	2,227	2,800	2,925
							1,720	2,139	2,689	2,809
							1,654	2,056	2,585	2,700
							1,591	1,978	2,486	2,597
								1,904	2,393	2,500
								1,834	2,306	2,408
								1,768	2,223	2,322
								1,705	2,144	2,239
								1,646	2,069	2,162
								1,590	1,999	2,088
								1,536	1,931	2,018
										1,951
										1,887
										1,827
										1,769
										1,715
										1,662
										1,612
										1,565
										1,519
										1,475
										1,433

Table 10.3—Typical Small Reel Dimensions

Reel	Reel dimensions (See Figure 10.2 below)					Approx. Reel Weight (lb.)	Material
	A	B	D	T	W		
	Flange Diameter (in.)	Arbor Hole (in.)	Drum Diameter (in.)	Traverse (in.)	Overall Width (in.)		
1	12	1 1/2	6	6	6 3/4	2 1/2	Plywood
2	13	1 1/2	5	12 3/4	12 3/4	3 3/4	Plywood
3	16	1 1/2	5	12	12 3/4	4 1/2	Plywood
4	24	2	12	14	15	11	Plywood
5	30	2	12	14	15	21	Plywood
6	1 1/8	2	8	3 5/8	4	2	Plastic
7	16	2	12	3 1/4	3 3/4	4 1/4	Fiberboard
8	6 1/2	3/4	1 1/8 1/16	1 1/2	1 3/4	1/2	Metal
9	6 1/2	3/4	1 1/8 1/16	2	2 1/4	1/2	Metal
10	6 1/2	3/4	1 1/8 1/16	3 1/4	3 1/2	1/2	Metal
11	6 1/2	3/4	1 1/8 1/16	7 1/2	7 3/4	3/4	Metal
12	10 1/2	1 5/8	3 1/2	2 3/4	3	1 1/4	Metal
13	10 1/2	1 5/8	3 1/2	8	8 1/4	1 3/4	Metal

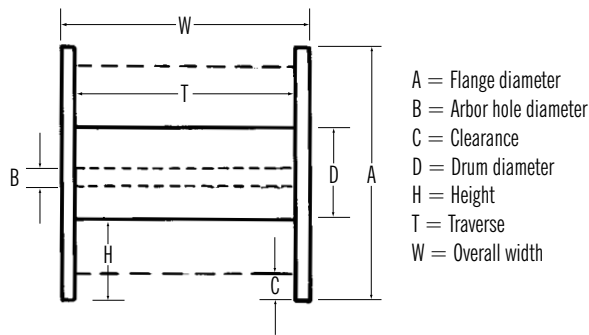

Figure 10.2—Reel Dimension



## 10.2 REEL HANDLING

### 10.2.1 Storage and Shipment

Except for reels less than two feet in diameter and weighing less than 200 pounds, reels should be stored and shipped upright, i.e., resting on both flanges. Do not store or ship reels on their side. Storage or shipment of the reel while lying on its side greatly increases the likelihood of tangling and damage to the cable.

Both cable ends should be sealed against the entrance of moisture. Cables larger than 1/2 inch in diameter should be sealed with tight-fitting heat-shrinkable or hot-dipped (peel coat) end caps designed for the purpose. Smaller diameter cables should be sealed with PVC tape such as 3M Scotch 33 or with end caps (end caps preferred), duct tape may be used in emergencies but not for long term sealing as it's prone to deterioration.

**CAUTION:** Make sure staples are shorter than flange thickness so that they cannot extend through the flange and damage the cable. Caution must also be used to prevent damage to the cable end as it is frequently utilized for hipot, continuity, or other tests. Be sure all staples and nails that might damage the cable are removed.

If reels of cable will be stored for longer than one month, they should be protected from rain and direct exposure to sunlight to maximize service life.

Care should be taken so as not to "rack" the reel. Wooden reels may have nails or bolts come loose if racked during rough handling which may result in cable damage.

### 10.2.2 Moving and Lifting

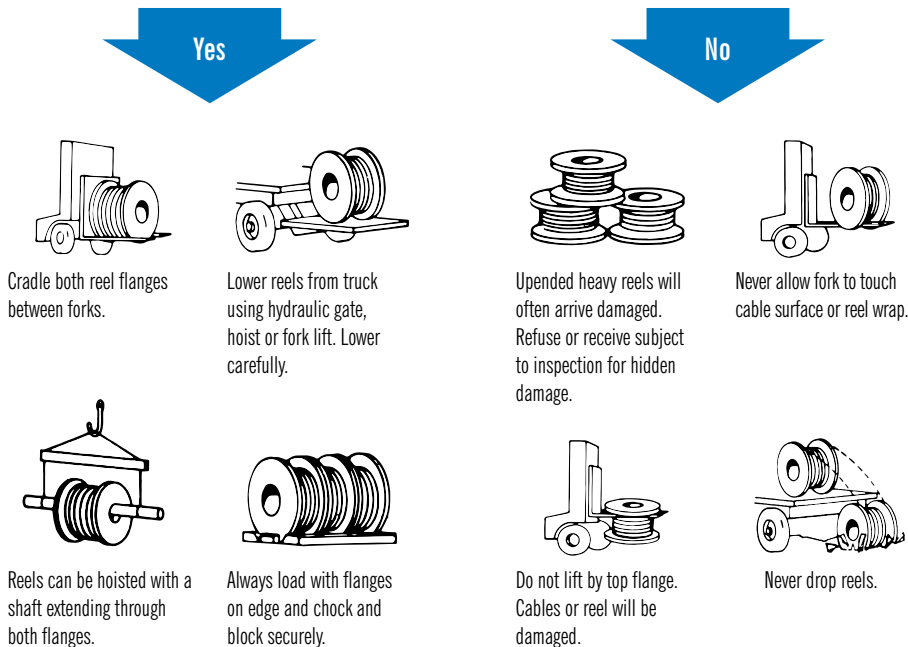

Figure 10.3—Proper Handling of Cable Reels



# 11. INDUSTRY STANDARDS

<b>11.1</b>	<b>Industry Standards List</b>	<b>161</b>
11.1.1	AAR	161
11.1.2	AEIC	161
11.1.3	ANSI	162
11.1.4	ASTM	162
11.1.5	Telcordia (formerly Bellcore)	164
11.1.6	CANENA	165
11.1.7	ECA	165
11.1.8	EIA	166
11.1.9	FAA	166
11.1.10	ICEA	166
11.1.11	IEC	167
11.1.12	IEEE	169
11.1.13	ISA	170
11.1.14	ISO	170
11.1.15	ITU-T	170
11.1.16	MSHA	170
11.1.17	NEMA	171
11.1.18	NFPA	171
11.1.19	RUS	172
11.1.20	SAE International (formerly Society of Automotive Engineers)	172
11.1.21	TIA	173
11.1.22	UL	173
11.1.23	U.S. Government Specifications	175

# 11. INDUSTRY STANDARDS

<b>11.2</b>	<b>Fire Safety Tests</b>	<b>176</b>
11.2.1	Fire Safety Test Methods	176
11.2.2	NEC Fire Test Summary	176
11.2.3	Comparison of Vertical Cable Tray Tests	177
11.2.4	NFPA 262 Steiner Tunnel Test for Plenum Rated Cable	178
11.2.5	UL 1666 Riser Flame Test	179
11.2.6	UL 1685 Vertical Tray Flame Test	179
11.2.7	ICEA T-29-520	180
11.2.8	UL VW-1 (Vertical Specimen) Flame Test	181
<b>11.3</b>	<b>Regulatory and Approval Agencies</b>	<b>182</b>
11.3.1	Underwriters Laboratories	182
11.3.2	National Electrical Code (NEC)	183
11.3.3	International	185

## 11.1 INDUSTRY STANDARDS LIST

### 11.1.1 AAR

#### Association of American Railroads

[www.aar.org](http://www.aar.org) or [www.arema.org](http://www.arema.org)

Document No.	Title
581.3	Specification for Single Conductor, Clean Stripping Rubber Insulated, 0–600 Volt, Neoprene Jacketed Cable for Locomotive and Car Equipment
S-501	Wiring and Cable Specification
S-502	Specification for Single Conductor, Chlorosulfonated Polyethylene Integral Insulated-Jacketed, 0–300 Volt, 0–600 Volt Cable for Locomotive and Car Equipment
S-503	Specification for Single Conductor, Silicone Rubber Insulation, 0–300 Volt, 0–600 Volt, Glass Polyester Braided, 125°C Cable for High Temperature Use on Locomotive and Car Equipment
S-506	Specification for Single Conductor, Clean Stripping Ethylene Rubber Insulated, 0–600 Volt, Chlorosulfonated Polyethylene Jacketed Cable for Locomotive and Car Equipment
S-4210	ECP Brake System Cable
–	Communications and Signals Manual, Section 10, Wire and Cable

### 11.1.2 AEIC

#### Association of Edison Illuminating Companies

[www.aeic.org](http://www.aeic.org)

Document No.	Title
CG1	Guide for Establishing the Maximum Operating Temperatures of Impregnated Paper and Laminated Paper Polypropylene Insulated Cables
CG3	Installation of Pipe-Type Cable Systems
CG4	Installation of Extruded Dielectric Insulated Power Cable Systems Rated 69 kV through 138 kV
CG5	Underground Extruded Cable Pulling Guide
CG6	Guide for Establishing the Maximum Operating Temperatures of Extruded Dielectric Insulated Shielded Power Cables
CG7	Guide for Replacement and Life Extension of Extruded Dielectric 5 through 35 kV Underground Distribution Cables
CG8	Guide for Electric Utility Quality Assurance Program for Extruded Dielectric Power Cables
CG9	Guide for Installing, Operating and Maintaining Lead Covered Cable Systems Rated 5KV through 46KV
CG11	Reduced Diameter Extruded Dielectric Shielded Power Cables Rated 5 through 46 kV
CG13	Guide for Testing Moisture Impervious Barriers Made of Laminated Foil Bonded to the Jacket of XLPE Transmission Cables
CS1	Impregnated Paper-Insulated, Metallic-Sheathed Cable Solid Type
CS2	Impregnated Paper-Insulated Cable, High-Pressure Pipe Type
CS3	Impregnated Paper-Insulated, Metallic-Sheathed, Low Pressure, Gas-Filled
CS4	Impregnated Paper-Insulated Low and Medium-Pressure Self-Contained, Liquid-Filled Cable
CS7	Cross-Linked Polyethylene Insulated Shielded Power Cables, 69 through 138 kV (replaced by CS9)
CS8	Extruded Dielectric Shielded Power Cables Rated 5 through 46 kV
CS9	Extruded Insulation Power Cables and Accessories Rated Above 46 kV through 345 kV
CS31	Electrically Insulating Low Viscosity Pipe Filling Liquids for High-Pressure Pipe-Type Cables

## 11. Industry Standards

### 11.1.3 ANSI

#### American National Standards Institute

[www.ansi.org](http://www.ansi.org)

Document No.	Title
0337-D	Local Distributed Data Interface (LDDI) Network Layer Protocol
0338-D	Data-Link Layer Protocol for Local Distributed Data Interfaces
0382-D	Fiber Distributed Data Interface (FDDI) Network Layer Protocol
0503-D	Fiber Distributed Data Interface (FDDI) Station Management Standard
0684-D	FDDI—Media Access Control
719	Nonmetallic-Sheathed Cables
X3.129	Intelligent Peripheral Interface (IPI) Enhanced Physical Interface (withdrawn)
X3.148	Fiber Distributed Data Interface (FDDI) Physical Layer (replaced by document #INCITS 148)
X3.184	Fiber Distributed Data Interface (FDDI) Single-Mode Fiber Physical Layer Medium Dependent (replaced by document #INCITS 184)

### 11.1.4 ASTM

#### American Society for Testing and Materials

[www.astm.org](http://www.astm.org)

Document No.	Title
B1	Hard-Drawn Copper Wire
B2	Medium-Hard-Drawn Copper Wire
B3	Soft or Annealed Copper Wire
B8	Concentric-Lay-Stranded Copper Conductors, Hard, Medium-Hard, or Soft
B33	Tinned Soft or Annealed Copper Wire
B47	Copper Trolley Wire
B49	Hot-Rolled Copper Rods
B105	Hard-Drawn Copper Alloy Wires for Electrical Conductors
B172	Rope-Lay-Stranded Copper Conductors (Bunch Stranded Members)
B173	Rope-Lay-Stranded Copper Conductors (Concentric Stranded Members)
B174	Bunch-Stranded Copper Conductors
B189	Lead-Alloy-Coated Soft Copper Wire
B193	Resistivity of Electrical Conductor Materials
B227	Hard-Drawn Copper Clad Steel Wire
B228	Concentric-Lay-Stranded Copper-Clad Steel Conductors
B229	Concentric-Lay-Stranded Copper and Copper-Clad Steel Composite Conductors
B230	Aluminum 1350-H19 Wire, for Electrical Purposes
B231	Concentric-Lay-Stranded Aluminum 1350 Conductors
B232	Concentric-Lay-Stranded Aluminum Conductors, Coated-Steel Reinforced (ACSR)
B233	Aluminum 1350 Drawing Stock for Electrical Purposes
B246	Tinned Hard-Drawn and Medium-Hard-Drawn Copper Wire

Continued >>

## 11.1.4 ASTM (Continued)

Document No.	Title
B258	Standard Nominal Diameters and Cross-Sectional Areas of AWG Sizes of Solid Round Wire Used as Electrical Conductors
B263	Determination of Cross-Sectional Area of Stranded Conductors
B298	Silver-Coated Soft or Annealed Copper Wire
B324	Aluminum Rectangular and Square Wire
B399	Concentric-Lay-Stranded Aluminum Alloy 6201-T81 Conductors
B400	Compact Round Concentric-Lay-Stranded Aluminum 1350 Conductors
B401	Compact-Round Concentric-Lay-Stranded Aluminum Conductors, Steel Reinforced (ASCR/COMP)
B452	Copper-Clad Steel Wire for Electronic Application
B496	Compact Round Concentric-Lay-Stranded Copper Conductors
B500	Metallic Coated Stranded Steel Core for Aluminum Conductors, Steel Reinforced (ACSR)
B549	Concentric-Lay-Stranded Aluminum Conductors, Aluminum Clad Steel Reinforced (ACASR/AW)
B566	Copper-Clad Aluminum Wire
B609	Aluminum 1350 Round Wire, Annealed and Intermediate Tempers
B624	High Strength, High Conductivity, Copper Alloy Wire
B694	Copper, Copper Alloy, Copper-Clad Bronze, Copper-Clad Stainless Steel and Strip for Electrical Cable Shielding
B736	Aluminum; Aluminum Alloy, Aluminum Clad Steel Cable Shielding Stock
B800	8000 Series Aluminum Alloy Wire
B801	Concentric-Lay-Stranded Conductors of 8000 Series Aluminum Alloy
D470	Test Methods for Cross-Linked Insulations and Jackets for Wire and Cable
D866	Styrene-Butadiene (SBR) Synthetic Rubber Jacket for Wire and Cable
D1047	Polyvinyl Chloride Jacket for Wire and Cable
D1351	Polyethylene-Insulated Wire and Cable
D1523	Synthetic Rubber Insulation for Wire and Cable, 90°C Operation
D1929	Test for Ignition Temperature of Plastics
D2219	Polyvinyl Chloride Insulation for Wire and Cable, 60°C Operation
D2220	Polyvinyl Chloride Insulation for Wire and Cable, 75°C Operation
D2308	Polyethylene Jacket for Electrical Insulated Wire and Cable
D2655	Cross-linked Polyethylene Insulation for Wire and Cable Rated 0 to 2,000 V
D2656	Cross-linked Polyethylene Insulation for Wire and Cable Rated 2,001 V to 35 kV
D2671	Test Methods for Heat-Shrinkable Tubing
D2768	General-Purpose Ethylene-Propylene Rubber Jacket for Wire and Cable
D2770	Ozone-Resisting Ethylene Propylene Rubber Integral Insulation and Jacket for Wire
D2802	Ozone Resistant Ethylene-Alkene Polymer Insulation for Wire and Cable
D2863	Test Method for Measuring the Minimum Oxygen Concentration to Support Candle-Like Combustion of Plastics (Oxygen Index)
D3554	Track-Resistant Black Thermoplastic High Density Polyethylene Insulation for Wire and Cable
0337-D	Local Distributed Data Interface (LDDI) Network Layer Protocol
0338-D	Data-Link Layer Protocol for Local Distributed Data Interfaces
0382-D	Fiber Distributed Data Interface (FDDI) Network Layer Protocol

Continued &gt;&gt;

## 11. Industry Standards

### 11.1.4 ASTM (Continued)

Document No.	Title
D3555	Track-Resistant Black Cross-linked Thermosetting Polyethylene Insulation for Wire and Cable
D4244	General Purpose, Heavy-Duty and Extra-Heavy-Duty NBR/PVC Jackets for Wire and Cable
D4245	Ozone-Resistant Thermoplastic Elastomer Insulation for Wire and Cable, 90°C Dry–75°C Wet Operation
D4246	Ozone-Resistant Thermoplastic Elastomer Insulation for Wire and Cable, 90°C Operation
D4314	Specification for General Purpose, Heavy-Duty and Extra-Heavy-Duty Cross-linked Chlorosulfonated Polyethylene Jackets for Wire and Cable
D4565	Test Methods for Physical and Environmental Performance Properties of Insulations and Jackets for Telecommunications Wire and Cable
D4566	Test Methods for Electrical Performance Properties of Insulations and Jackets for Telecommunications Wire and Cable
D5537	Heat Release, Flame Spread and Mass Loss Testing of Insulating Materials Contained in Electrical or Optical Fiber Cables When Burning in a Vertical Cable Tray Configuration
E574	Duplex, Base Metal Thermocouple Wire with Glass Fiber or Silica Fiber Insulation
E662	Specific Optical Density of Smoke Generated by Solid Materials
E1354	Heat and Visible Smoke Release Rates for Materials and Products Using an Oxygen Consumption Calorimeter

### 11.1.5 Telcordia (formerly Bellcore)

[www.telcordia.com](http://www.telcordia.com)

Document No.	Title
GR-20	Generic Requirements for Optical Fiber and Optical Fiber Cable
GR-63	Network Equipment-Building System Requirements: Physical Protection
GR-78	Generic Physical Design Requirements for Telecommunication Products and Equipment
GR-110	Generic Requirements for Thermoplastic Insulated Steam Resistant Cable
GR-111	Generic Requirements for Thermoplastic Insulated Riser Cable
GR-115	Inner-City PIC Screened Cable (Filled, AASP Bonded, STALPETH and Bonded PASP)
GR-126	Generic Requirements for Network Outdoor Customer Premises and Universal Cross-Connecting Wire
GR-135	Generic Requirements for Miniature Ribbon Connector and Cable Assembly
GR-136	Generic Requirements for Distributing Frame Wire
GR-137	Generic Requirements for Central Office Cable
GR-139	Generic Requirements for Central Office Coaxial Cable
GR-326	Generic Requirements for Singlemode Optical Connectors and Jumpers
GR-347	Generic Requirements for Telecommunications Power Cable
GR-356	Generic Requirements for Optical Cable Innerduct
GR-409	Generic Requirements for Premises Optical Fiber Cable
GR-421	Generic Requirements for Metallic Telecommunications Cable
GR-492	Generic Requirements for Metallic Telecommunication Wire
GR-1398	Generic Requirements for Coaxial Drop Cable
GR-1399	Generic Requirements for Coaxial Distribution Cable
TR-NWT-000123	Single Pair Buried Distribution Wire
TR-NWT-000124	Multiple Pair Buried Wire
TR-NWT-000131	Generic Requirements for Network Plenum Cable/Wire
TR-NWT-000132	Generic Requirements for Network Shielded Station Wire
TR-NWT-000133	Generic Requirements for Inside Wiring Cable (3 to 125 Pair Sizes)

Continued >>



**11.1.5 Telcordia (Continued)**

Document No.	Title
TR-NWT-000134	Generic Requirements for Two Pair Station Wire
TR-TSY-000103	Pulp Bonded STALPETH Cable
TR-TSY-000104	Pulp Bonded PASP Cable
TR-TSY-000105	Pulp Bonded Steam Resistance Cable
TA-TSY-000120	Customer Premises or Network Ground Wire
TA-TSY-000121	Generic Requirements for One-Pair Aerial Service Wire
TA-TSY-000122	Generic Requirements for Multiple-Pair Aerial Service Wire
TA-TSY-000125	Rural Aerial Distribution Wire
TA-TSY-000127	Network Aerial Block Wire
TA-TSY-000128	Bridle Wire
TA-TSY-000129	Tree Wire
TA-TSY-000140	Standard Shielded Polyethylene Insulated Twisted Pair Cable
TA-TSY-000141	Terminating Cable
TA-TSY-000142	Central Office Hook-up Wire

**11.1.6 CANENA**

**Council for the Harmonization of Electrical Standards of the Americas**

[www.canena.org](http://www.canena.org)

**THC (Technical Harmonization Committee) #20 is responsible for wire and cable products.**

**11.1.7 ECA**

**Electronic Components, Assemblies and Materials Association**

[www.ec-central.org](http://www.ec-central.org)

Document No.	Title
ECA-199-A	Solid and Semisolid Dielectric Transmission Lines
ECA-215	Broadcast Microphone Cables
ECA-230	Color Marking of Thermoplastic Covered Wire
ECA-280-C	Solderless Wrapped Electrical Connections
ECA-297-A	Cable Connectors for Audio Facilities for Radio Broadcasting
ECA-364	Electrical Connector Test Procedures
ECA-403-A	Precision Coaxial Connectors for CATV 75 Ohms
ECA-IS-43	Omnibus Specification—Local Area Network Twisted Pair Data Communication Cable
ECA-IS-43AA	Cable for LAN Twisted Pair Data Communications—Detail Specification for Type 1, Outdoor Cable
ECA-IS-43AB	Cable for LAN Twisted Pair Data Communications—Detail Specification for Type 1, Non-Plenum Cable
ECA-IS-43AC	Cable for LAN Twisted Pair Data Communications—Detail Specification for Type 1, Riser Cable
ECA-IS-43AD	Cable for LAN Twisted Pair Data Communications—Detail Specification for Type 1, Plenum Cable
ECA-IS-43AE	Cable for LAN Twisted Pair Data Communications—Detail Specification for Type 2, Non-Plenum Cable
ECA-IS-43AF	Cable for LAN Twisted Pair Data Communications—Detail Specification for Type 2, Plenum Cable
ECA-IS-43AG	Cable for LAN Twisted Pair Data Communications—Detail Specification for Type 6, Office Cable
ECA-IS-43AH	Cable for LAN Twisted Pair Data Communications—Detail Specification for Type 8, Undercarpet Cable
ECA-IS-43AJ	Cable for LAN Twisted Pair Data Communications—Detail Specification for Type 9, Plenum Cable

**11.1.8 EIA**

**Electronic Industries Alliance**

[www.eia.org](http://www.eia.org)

EIA documents are available from Global Engineering Documents, Inc. [www.global.ihs.com](http://www.global.ihs.com)

Document No.	Title
EIA-492A000	Specification for Multimode Optical Wave Guide Fibers
EIA-359-A	Standard Colors for Color Identification and Coding (Munsell Color)

**11.1.9 FAA**

**Federal Aviation Administration**

[www.faa.gov](http://www.faa.gov)

Document No.	Title
AC 25.869-1	Fire and Smoke Protection
AC 150/534-7	Underground Electrical Cables for Airport Lighting Circuits (L-824-A, B, C)
AC-150/5345-53	Airport Lighting Certification Program
AC-150/5370-10	Airport Construction Standards
FAA-E-2042	Control Cable, Exterior
FAA-E-2793	Power Cable, Exterior, 5 to 25 kV
FAA-701	Rubber-Insulated Cable (0–8,000 Volts)
FAR 14, 25.869 (a)(4)	Fire Retardance of Wire and Cable

**11.1.10 ICEA**

**Insulated Cable Engineers Association**

[www.icea.net](http://www.icea.net)

ICEA documents are available from Global Engineering Documents, Inc. [www.global.ihs.com](http://www.global.ihs.com)

Document No.	Title
S-56-434	Polyolefin Insulated Communication Cables for Outdoor Use
S-61-402	Thermoplastic-Insulated Wire and Cable for the Transmission and Distribution of Electrical Energy (NEMA WC 5) (withdrawn)
S-81-570	600 V Direct Burial Cable Single Electrical Conductors and Assemblies with Ruggedized Extruded Insulation
P-32-382	Short Circuit Characteristics of Insulated Cable
P-43-457	Conductor Resistances and Ampacities at 400 and 800 Hz
P-45-482	Short Circuit Performance of Metallic Shields and Sheaths on Insulated Cable
P-46-426	Power Cable Ampacities (Replaced by IEEE 835)
P-51-432	Copper Conductors, Bare and Weather Resistant
P-53-426	Ampacities, Including Effect of Shield Losses for Single-Conductor Solid-Dielectric Power Cable 15 kV Through 69 kV (NEMA WC 50)
P-54-440	Ampacities of Cables in Open-Top Cable Trays (NEMA WC 51)
P-56-520	Cable Tray Flame Test
S-65-375	Varnished-Cloth-Insulated Wire and Cable for the Transmission and Distribution of Electrical Energy (NEMA WC 4) (rescinded)
S-70-547	Weather-Resistant Polyethylene Covered Conductors

Continued >>

**11.1.10 ICEA (Continued)**

Document No.	Title
S-73-532	Standard for Control Cables (NEMA WC 57)
S-75-381	Portable and Power Feeder Cables for Use in Mines and Similar Applications (NEMA WC 58)
S-80-576	Category 1 and 2 Unshielded Twisted Pair Communications Cable for Wiring Premises
S-82-552	Instrumentation Cables and Thermocouple Wire (NEMA WC 55) (withdrawn, see S-73-532)
S-83-596	Optical Fiber Premises Distribution Cable
S-87-640	Fiber Optic Outside Plant Communications Cable
S-94-649	Concentric Neutral Cables Rated 5 through 46 kV
S-97-682	Utility Shielded Power Cables Rated 5 through 46 kV
S-104-696	Indoor-Outdoor Optical Fiber Cable
S-110-717	Optical Fiber Drop Cable
T-22-294	Test Procedures for Extended Time-Testing of Insulation for Service in Wet Locations
T-25-425	Guide for Establishing Stability of Volume Resistivity for Conducting Polymeric Components of Power Cables
T-26-465	Guide for Frequency of Sampling Extruded Dielectric Power, Control, Instrumentation and Portable Cables for Test (NEMA WC 54)
T-27-581	Standard Test Methods for Extruded Dielectric Power, Control, Instrumentation and Portable Cables (NEMA WC 53)
T-29-520	Conducting Vertical Cable Tray Flame Tests (210,000 BTU/Hour)
T-30-520	Conducting Vertical Cable Tray Flame Tests (70,000 BTU/Hour)
T-31-610	Water Penetration Resistance Test, Sealed Conductor
T-33-655	Low-Smoke, Halogen-Free (LSHF) Polymeric Cable Jackets

**11.1.11 IEC****International Electrotechnical Commission**

[webstore.iec.ch](http://webstore.iec.ch)

Document No.	Title
24764	Information Technology—Generic Cabling for Data Center Premises
60050-461	International Electrotechnical Vocabulary. Chapter 461. Electric cables.
60055-2	Paper-insulated metal-sheathed cables for rated voltages up to 18/30 kV (with copper or aluminum conductors and excluding gas pressure and oil-filled cables)
60079	Electrical apparatus for explosive atmospheres (hazardous locations)
60092	Electrical installations in ships
60096	Radio-frequency cables
60141	Tests on oil-filled and gas-pressure cables and their accessories
60169	Radio-frequency connectors
60173	Colors of the cores of flexible cables and cords
60183	Guide to selection of high-voltage cables
60189	Low-frequency cables and wires with PVC insulation and PVC sheath
60204	Safety of machinery—electrical equipment of machines (industrial)
60227	PVC insulated cables of rated voltages up to and including 450/750 V
60228	Conductors of insulated cables
60229	Tests on cable oversheaths which have a special protective function and are applied by extrusion

Continued >>

### 11.1.11 IEC (Continued)

Document No.	Title
60230	Impulse tests on cables and their accessories
60245	Rubber insulated cables of rated voltages up to and including 450/750 V
60230	Impulse tests on cables and their accessories
60245	Rubber insulated cables of rated voltages up to and including 450/750 V
60287	Calculations of the continuous current rating of cables (100% load factor)
60304	Standard colors for insulation for low-frequency cables and wires
60331	Tests for electric cables under fire conditions—circuit integrity
60332	Tests on electric and optical fiber cables under fire conditions
60339	General purpose rigid coaxial transmission lines and their associated flange connectors
TR60344	Calculation of DC resistance of plain and coated copper conductors of low-frequency cables and wires
60364-1	Low-voltage electrical installations—Part 1: Fundamental principles, assessment of global characteristics, definitions
60446	Identification of conductors by colors or alphanumeric
60457	Rigid precision coaxial lines and their associated precision connectors
60502	Extruded solid dielectric insulated power cables for rated voltages from 1 kV to 30 kV
60541	Comparative information on IEC and North American flexible cord types
TR60649	Calculation of maximum external diameter of cables for indoor installations
60695	Fire hazard testing
60702	Mineral insulated cables with a rated voltage not exceeding 750 V
60708	Low-frequency cables with polyolefin insulation and moisture barrier polyolefin sheath
60719	Calculation of the lower and upper limits for the average outer dimensions of cables with circular copper conductors and of rated voltages up to and including 450/750 V
60724	Short-circuit temperature limits of electric cables with rated voltages 1 kV and 3 kV
60728	Cable networks for sound and television signals
60754	Tests on gases evolved during combustion of electric cables
60757	Code for designation of colors
60800	Heating cables with a rated voltage of 300/500 V for comfort heating and prevention of ice formation
60811	Common tests methods for insulating and sheathing materials of electric and optical cables
60834	Performance and testing of teleprotection equipment of power systems
60840	Tests for power cables with extruded insulation for rated voltages above 30 kV up to 150 kV
60851	Winding wires—test methods
60885	Electrical test methods for electric cables (including partial discharge)
60949	Calculation of thermally permissible short-circuit currents
60966	Radio-frequency and coaxial cable assemblies
61034	Measurement of smoke density of cables burning under defined conditions (3 meter cube smoke apparatus)
61158	Fieldbus for use in industrial control systems
61883	Consumer audio/video equipment—Digital interface
61936-1	Power installations exceeding 1 kV AC Part 1: Common rules

## 11.1.12 IEEE

Institute of Electrical and Electronic Engineers, Inc.

www.ieee.org

Document No.	Title
45	Recommended Practice for Electrical Installations on Shipboard
48	Test Procedures and Requirements for AC Cable Terminations 2.5 kV through 765 kV
82	Test Procedure for Impulse Voltage Tests on Insulated Conductors
101	Guide for the Statistical Analysis of Thermal Life Test Data
120	Master Test Guide for Electrical Measurements in Power Circuits
323	Qualifying Class 1E Equipment for Nuclear Power Generating Stations
383	Qualifying Class 1E Electric Cables, Field Splices and Connections for Nuclear Power Generating Stations
400	Guide for Field Testing and Evaluation of the Insulation of Shielded Power Cable Systems
404	Standard for Extruded and Laminated Dielectric Shielded Cable Joints Rated 2.5 kV through 500 kV
422	Guide for Design and Installation of Cable Systems in Power Generating Stations (withdrawn)
510	Recommended Practices for Safety in High Voltage and High Power Testing
524	Guide to the Installation of Overhead Transmission Line Conductors
525	Guide for the Design and Installation of Cable Systems in Substations
532	Guide for Selecting and Testing Jackets for Underground Cables
539	Definitions of Terms Relating to Corona and Field Effects of Overhead Powerlines
575	Guide for the Application of Sheath-Bonding Methods for Single Conductor Cables and the Calculation of Induced Voltages and Currents in Cable Sheaths
576	Recommended Practice for Installation, Termination, and Testing of Insulated Power Cable as Used in Industrial and Commercial Applications
634	Standard Cable Penetration Fire Stop Qualification Test
635	Guide for Selection and Design of Aluminum Sheaths for Power Cables
690	Standard for the Design and Installation of Cable Systems for Class 1E Circuits in Nuclear Power Generating Stations
738	Standard for Calculating the Current-Temperature of Bare Overhead Conductors
802	Local and Metropolitan Area Networks: Overview and Architecture
816	Guide for Determining the Smoke Generation of Solid Materials Used for Insulations and Coverings of Electrical Wire and Cable (withdrawn)
835	Power Cable Ampacity Tables
848	Standard Procedure for the Determination of the Ampacity Derating of Fire-Protected Cables
930	Statistical Analysis of Electrical Insulation Breakdown Data
1017	Field Testing Electric Submersible Pump Cable
1018	Specifying Electric Submersible Cable-Ethylene-Propylene Rubber Insulation
1019	Specifying Electric Submersible Pump Cable-Polypropylene Insulation
1143	Guide on Shielding Practice for Low Voltage Cables
1185	Guide for Installation Methods for Generating Station Cables
1202	Standard for Propagation Flame Testing of Wire and Cable
1394	Standard for a High Performance Serial Bus
1407	Guide for Accelerated Aging Test for MV Power Cables Using Water-Filled Tanks
1580	Marine Cable For Use on Shipboard and Fixed or Floating Facilities
C2	National Electrical Safety Code (NESC)
C62.41	Surge Voltages in Low-Voltage (1,000 V and less) AC Power Circuits
C62.92	Neutral Grounding in Electrical Utility Systems
1580	Marine cable for use on shipboard and fixed or floating facilities

## 11. Industry Standards

---

### 11.1.13 ISA

**Instrumentation, Systems and Automation Society**

[www.isa.org](http://www.isa.org)

Document No.	Title
RP 12.06.01	Wiring Methods for Hazardous (Classified) Locations Instrumentation Part 1: Intrinsic Safety
50.02	Fieldbus Standard for Use in Industrial Control Systems

### 11.1.14 ISO

**International Organization for Standardization**

[www.iso.org](http://www.iso.org)

Document No.	Title
4589	Oxygen Index Test
5657	Radiant Cone Flame Test
TR9122	Toxicity Testing of Fire Effluents

### 11.1.15 ITU-T

**International Telecommunication Union/Telecommunications Sector**

[www.itu.int](http://www.itu.int)

Document No.	Title
Blue Book, Facicle III.3	Transmission Media Characteristics

### 11.1.16 MSHA

**Mine Safety and Health Administration**

[www.msha.gov](http://www.msha.gov)

Document No.	Title
30 CFR 7.407	Flame Tests

**11.1.17 NEMA****National Electrical Manufacturers Association**[www.nema.org](http://www.nema.org)

Document No.	Title
HP 3	Electrical and Electronic PTFE Insulated High Temperature Hook-up Wire; Types ET (250 Volts), E (600 Volts) and EE (1,000 Volts)
HP 4	Electrical and Electronic FEP Insulated High Temperature Hook-up Wire; Types KT (250 Volts), K (600 Volts) and KK (1,000 Volts)
HP 100	High Temperature Instrumentation and Control Cable
HP 100.1	High Temperature Instrumentation and Control Cables Insulated and Jacketed with FEP Fluorocarbons
HP 100.2	High Temperature Instrumentation and Control Cables Insulated and Jacketed with ETFE Fluoropolymers
HP 100.3	High Temperature Instrumentation and Control Cables Insulated and Jacketed with Cross-Linked (Thermoset) Polyolefin (XLPO)
HP 100.4	High Temperature Instrumentation and Control Cables Insulated and Jacketed with ECTFE Fluoropolymers
WC 26	Wire and Cable Packaging
WC 50	Ampacities, Including Effect of Shield Losses for Single-Conductor Solid-Dielectric Power Cable 15 kV through 69 kV (ICEA P-53-426)
WC 51	Ampacities of Cables Installed in Cable Trays
WC 52	High-Temperature and Electronic Insulated Wire Impulse Dielectric Testing
WC 53	Standard Test Methods for Extruded Dielectric Power, Control, Instrumentation and Portable Cables (ICEA T-27-581)
WC 54	Guide for Frequency of Sampling Extruded Dielectric Power, Control, Instrumentation and Portable Cables for Test
WC 56	3.0 kHz Insulation Continuity Proof Testing of Hookup Wire
WC 57	Standard for Control Cables (ICEA S-73-532)
WC 58	Portable and Power Feeder Cables for Use in Mines and Similar Applications (ICEA S-75-381)
WC 61	Transfer Impedance Testing
WC 62	Repeated Spark/Impulse Dielectric Testing
WC 63.1	Twisted Pair Premise Voice and Data Communications Cables
WC 63.2	Coaxial Premise Data Communication Cable
WC 66	Category 6 and Category 7 100 Ohm Shielded and Unshielded Twisted Pair Cables
WC 67	Uninsulated Conductors
WC 70	Nonshielded Power Cables Rated 2,000 Volts or Less
WC 71	Nonshielded Cables Rated 2,001–5,000 Volts
WC 27500	Aerospace and Industrial Electrical Cable

**11.1.18 NFPA****National Fire Protection Association**[www.nfpa.org](http://www.nfpa.org)

Document No.	Title
70	NEC <sup>®</sup> (National Electrical Code)
75	Protection of Electronic Computer/Data Processing Equipment
79	Electrical Standard for Industrial Machinery
99	Health Care Facilities Handbook
130	Fixed Guideway Transit and Passenger Rail Systems
258	Recommended Practice for Determining Smoke Generation of Solid Materials
262	Test for Flame Travel and Smoke of Wires and Cables for Use in Air-Handling Spaces

## 11. Industry Standards

---

### 11.1.19 RUS

#### Rural Utilities Service (formerly REA)

[www.rurdev.usda.gov](http://www.rurdev.usda.gov)

Document No.	Title
1753F-150	Construction of Direct Buried Plant
1753F-151	Construction of Underground Plant
1753F-152	Construction of Aerial Plant
1753F-204	Aerial Service Wires (PE-7)
1753F-205	Filled Telephone Cable (PE-39)
1753F-206	Filled Buried Wires (PE-86)
1753F-208	Filled Telephone Cable with Expanded Insulation (PE-89)
1753F-601	Filled Fiber Optic Cables (PE-90)

### 11.1.20 SAE International (formerly Society of Automotive Engineers)

[www.sae.org](http://www.sae.org)

Document No.	Title
J156	Fusible Links
J378	Marine Propulsion System Wiring
J1127	Low Voltage Battery Cable
J1128	Low Voltage Primary Cable
J1292	Automobile Truck, Truck-Tractor, Trailer, and Motor Coach Wiring
J1654	High Voltage Primary Cable
J1678	Low Voltage Ultra Thin Wall Primary Cable
J1939	Serial Control and Communications for Vehicle Network
J2394	Seven-Conductor Cable for ABS Power
J2549	Single Conductor Cable for Heavy Duty Application
AS22759	Fluoropolymer Insulated Electrical Wire
AS50861	PVC Insulated, Copper or Copper Alloy Wire
AS50881	Wiring Aerospace Vehicle
AS81044	Wire, Electric, Cross-linked Polyalkene, Cross-linked Alkane-Imide Polymer, or Polyarylene Insulated, Copper or Copper Alloy



**11.1.21 TIA****Telecommunication Industries Association**[www.tiaonline.org](http://www.tiaonline.org)

Document No.	Title
TIA-225	Rigid Coaxial Transmission Lines 50 Ohms
TIA-232-F	Interface Between Data Terminal Equipment and Data Communication Equipment Employing Serial Binary Data Interchange
TIA-259	Rigid Coaxial Transmission Lines and Connectors, 75 Ohms
TIA-422-B	Electrical Characteristics of Balanced Voltage Digital Interface Circuits
TIA-423-B	Electrical Characteristics of Unbalanced Voltage Digital Interface Circuits
TIA-440-B	Fiber Optic Terminology
TIA-485-A	Generators and Receivers for Balanced Digital Multipoint Systems
TIA-455-B	Standard Test Procedures for Fiber Optic Fibers, Cables, Transducers, Connecting and Termination
TIA-492AAAA-A	Detail Specification for 62.5 $\mu\text{m}$ Core Diameter/125 $\mu\text{m}$ Cladding Diameter Class 1a Multimode, Graded-Index Optical Waveguide Fibers
TIA-568-B.1	Commercial Building Telecommunications Cabling Standard
TIA-569-B	Commercial Building Standard for Telecommunications Pathways and Spaces
TIA-570-B	Residential Telecommunications Infrastructure Standard
TIA-606-A	Administration Standard for the Telecommunications Infrastructure
TIA-942	Telecommunications Infrastructure Standard for Data Centers
TIA-100S	Telecommunications Infrastructure Standard for Industrial Premises
TIA-472C000	Sectional Specification for Fiber Optic Premises Distribution Cables
TIA-472D000	Sectional Specification for Fiber Optic Cables for Outside Plant Use
TIA-475C000	Specification for Fiber Optic Type FSMA Connectors
TIA-515B000	Specification for Optical Fiber Cable Splice Closures

**11.1.22 UL****Underwriters Laboratories, Inc.**[www.ul.com](http://www.ul.com)

Document No.	Title
4	Armored Cable (Type AC)
13	Power-Limited Circuit Cable (Types CL3P, CL2P, CL3R, CL2R, CL3, CL3X, PLTC)
44	Thermoset-Insulated Wires & Cables (Types XHHW, XHHW-2, RHH, RHW, RHW-2, RH, SA, SIS)
62	Flexible Cord & Fixture Wire (Types SO, SOW, SOW-A, SJ, SJO, SPT-1, TFN, TFFN, etc.)
66	Fixture Wire
83	Thermoplastic-Insulated Wires and Cables (Types TW, THW, THW-2, THWN, THWN-2, THHN, THHW, TA, TBS, TFE, FEP, FEPB)
183	Manufactured Wiring Systems
444	Communication Cables (Types CMX, CM, CMR, CMP)
486A-486B	Wire Connectors
486C	Splicing Wire Connectors
486D	Sealed Wire Connector Systems
486E	Equipment Wiring Terminals for Use with Aluminum and/or Copper Conductors
493	Thermoplastic Insulated Underground Feeder & Branch Circuit Cables (Types UF, UF-B)

Continued &gt;&gt;

## 11. Industry Standards

### 11.1.22 UL (Continued)

Document No.	Title
497	Protectors for Communication Circuits
719	Nonmetallic-Sheath Cables (Types NM-B, NMC-B)
723	Tests for Surface Burning Characteristics of Building Materials
758	Appliance Wiring Material (Type AWM)
814	Gas-Tube-Sign Cable
817	Cord Sets and Power-Supply Cords
854	Service Entrance Cables (Types USE, SE, SE-U, SE-R, USE-2)
1063	Machine Tool Wires and Cables (Type MTW)
1072	Medium Voltage Power Cable (Type MV)
1276	Welding Cables
1277	Power and Control Tray Cables (Type TC)
1309	Marine Shipboard Cable
1424	Cables for Power-Limited Fire-Alarm Circuits
1425	Cables for Non-Power-Limited Fire-Alarm Circuits
1426	Electric Cables for Boats
1459	Telephone Equipment
1565	Positioning Devices
1581	Reference Standard for Electrical Wires, Cables, and Flexible Cords
1604	Electrical Equipment for Use in Class I and II, Division 2, and Class III Hazardous (Classified) Locations
1650	Portable Power Cable (Types G, G-GC, W, PPE)
1651	Optical Fiber Cable
1666	Standard Test for Flame Propagation Height of Electrical and Optical Fiber Cables Installed Vertically in Shafts
1680	Stage Lighting Cables
1685	Vertical-Tray Fire-Propagation and Smoke-Release Test for Electrical and Optical-Fiber Cables
1690	Data-Processing Cable (Type DP)
1740	Industrial Robots
1863	Communication Circuit Accessories
2196	Fire Resistive Cables ("CI" Rated)
2225	Cables for Use in Hazardous Locations (Type MC-HL)
2250	Instrumentation Tray Cable (Type ITC)
2556	Wire and Cable Test Methods (Trinational)
2261	Cables for Network-Powered Broadband Systems
2273	Festoon Cable
2276	Recreational Vehicle Cable
2424	Limited-Combustible Cable
60079	Electrical Apparatus for Explosive Gas Atmospheres

### 11.1.23 U.S. Government Specifications

<http://assist.daps.dla.mil/quicksearch>

Document No.	Title
AA-59544	Wire & Cable Electrical Power
A-A-59551	Electrical Copper Wire, Uninsulated
J-C-145C	Weather-Resistant Power & Cable
J-C-580B	Flexible Cord and Fixture Wire (Replaced by UL 62)
MIL-DTL-17H	General Specifications for Cables, Radio Frequency, Flexible and Semirigid
MIL-DTL-915G	General Specification for Cable and Cord, Electrical, for Shipboard Use
MIL-DTL-3432H	Cable (Power & Special Purpose) and Wire, Electrical (300–600 Volts)
MIL-DTL-8777D	Wire, Electrical, Silicone-Insulated, Copper, 600 V, 200°C
MIL-DTL-13777H	General Specifications for Cable, Special Purpose, Electrical
MIL-DTL-16878G	General Specifications for Wire, Electrical, Insulated
MIL-DTL-23806B	General Specification for Cable, Radio Frequency, Coaxial, Semirigid, Foam Dielectric
MIL-DTL-24640G	General Specification for Cable, Electrical, Lightweight for Shipboard Use
MIL-DTL-24643B	General Specification for Cable and Cord, Electrical, Low Smoke, for Shipboard Use
MIL-DTL-25038H	Wire, Electrical, High Temperature, Fire Resistant and Flight Critical
MIL-DTL-27072F	Special Purpose, Electrical, Multiconductor and Single Shielded Power Cable
MIL-DTL-28830D	General Specification for Cable, Radio Frequency, Coaxial, Semirigid, Corrugated Outer Conductor
MIL-DTL-38359C	Cable, Power, Electrical, Airport Lighting, Cross-Linked, Polyethylene XLP
MIL-DTL-49055D	General Specifications for Cables, Power, Electrical (Flexible, Flat, Unshielded), Round Conductor
MIL-DTL-55021C	General Specification for Cables Twisted Pairs and Triples, Internal Hookup
MIL-DTL-81381C	Wire-Electric, Polyimide-Insulated Copper or Copper Alloy
MIL-C-83522D	General Specification for Connectors, Fiber Optic, Single Terminus
MIL-DTL-83526C	General Specifications for Connectors, Fiber Optic, Circular, Environmental Resistant, Hermaphroditic
MIL-HDBK-299	Cable Comparison Handbook Data Pertaining to Electric Shipboard Cable
MIL-S-81824	Splices, Electric, Crimp Style, Copper, Insulated, Environment Resistant (replaced by SAE-AS 81824)
MIL-W-76D	Wire and Cable, Hookup, Electrical, Insulated
MIL-W-5846C	Wire, Electrical, Chromel and Alumel Thermocouple
QPL-AS5756-I	Cable and Wire, Power, Electric, Portable (replaced by Qualified Products Database)

## 11.2 FIRE SAFETY TESTS

### 11.2.1 Fire Safety Test Methods

**Table 11.1—Fire Safety Test Methods**

Some common fire safety test methods used in the wire and cable industry are listed below:

Fire Hazard	North America	Worldwide
Ignitability	ASTM D2863	IEC 60332
Propagation	UL 1685 and IEEE 1202	IEC 60332
Smoke	UL 1685 and ASTM E662	IEC 61034-2
Toxicity	University of Pittsburgh	ISO TR 9122
Corrosivity	IEC 60754	IEC 60754-2
Halogen Content	MIL-DTL-24643	IEC 60754-1

### 11.2.2 NEC Fire Test Summary

**Table 11.2—NEC Fire Test Summary**

National Electrical Code Article	Plenum (NFPA 262)	Riser (UL 1666)	General Use (Vertical Tray)	Limited Use (Vertical Wire)
645 Under Raised Floor of IT Room	All types shown below	All types shown below	DP, MC, AC	—
725, Class 2 Power-Limited	CL2P	CL2R	CL2	CL2X
725, Class 3 Power-Limited	CL3P	CL3R	CL3	CL3X
725 Power-Limited Tray Cable	No listing	No listing	PLTC	No listing
727 Instrumentation Tray Cable	No listing	No listing	ITC	No listing
760 Fire Protective Power-Limited	FPLP	FPLR	FPL	No listing
760 Fire Protective Non-Power-Limited	NPLFP	NPLFR	NPLF	No listing
770 Optical Fiber Nonconductive	OFNP	OFNR	OFN or OFNG	No listing
770 Optical Fiber Conductive	OFCP	OFNR	OFC or OFCG	No listing
800 Communication	CMP	CMR	CM or CMG	CMX
800 Undercarpet Communication	No listing	No listing	No listing	CMUC
820 Cable TV	CATVP	CATVR	CATV	CATVX

Cable Application	Common Names	Flame Energy
Plenum Space	NFPA 262, Steiner Tunnel, CSA FT6	300,000 Btu/hr
Riser Shaft	UL 1666, Riser Test	527,000 Btu/hr
General Use	Vertical Tray, IEEE 1202, CSA FT4, UL 1685	70,000 Btu/hr
Limited Use	Vertical Wire, VW-1, CSA FT1	3,000 Btu/hr

## 11.2.3 Comparison of Vertical Cable Tray Tests

Table 11.3—Comparison of Vertical Cable Tray Tests

	ICEA T-29-520	CSA FT4	IEEE 1202 <sup>j</sup>	UL 1685 /UL <sup>a</sup>	UL 1685 /IEEE <sup>b</sup>	IEC 60332-3
Burner power (kW)	62	20	20	21	21	20
Time of flame (min.)	20	20	20	20	20	20, 40g
Alternate source	No	No	No	No	No	No
Burner placements	300 mm 200 mm in back	300 mm 75 mm in front	300 mm 75 mm in front	457 mm 75 mm in back	457 mm 75 mm in front	600 mm 75 mm in front
Angle of burner	Horiz.	20° up	20° up	Horiz.	20° up	Horiz.
Tray length (m)	2.4	3.0	2.4	2.4	2.4	3.5
Tray width (m)	0.3	0.3	0.3	0.3	0.3	0.5
Sample length (m)	2.4	2.3	2.3	2.4	2.4	3.5
Width of tray used for cables (m)	0.15	0.25 front only	Full front only	0.15 front only	Full front only	0.30 front or front + back
Thin-size cables to be bundled	No	if D < 13 mm	if D < 13 mm	No	if D < 13 mm	Mounted flush, with no spaces
Test enclosure specified	No	Yes	Yes	Yes	Yes	Yes
Required air flow rate	N/A	>0.17 m <sup>3</sup> /s	0.65 m <sup>3</sup> /s	5 m <sup>3</sup> /s	5m <sup>3</sup> /s	<sup>h</sup>
Test runs needed	2	2	2 X 2 <sup>f</sup>	1	1	1
Max. char length (m, from bottom)	2.4	1.786	1.786	2.4	1.786	3.1
Peak smoke release rate (m <sup>2</sup> s <sup>-1</sup> )	N/A	N/A	N/A	0.25	0.40	N/A
Total smoke released (m <sup>2</sup> )	N/A	N/A	N/A	95	150	N/A

<sup>a</sup> = Version with UL 1581/2556 flame exposure; <sup>b</sup> = Version with CSA FT-4/IEEE 1202 flame exposure; <sup>c</sup> = Height above bottom of tray and distance from specimen surface, respectively; <sup>d</sup> = Not applicable in the UL 1581/2556 version; <sup>e</sup> = This dimension is 457 mm in the UL 1581/2556 version; <sup>f</sup> = Two each on two different sizes of specimens; <sup>g</sup> = Time is 20 minutes for Category C, 40 minutes for Categories A and B; <sup>h</sup> = Not yet specified; <sup>i</sup> = Depends on amount of cable loading <sup>j</sup> = IEEE 383 now directly references IEEE 1202

Source: NIST Technical Note 1291

### 11.2.4 NFPA 262 Steiner Tunnel Test for Plenum Rated Cable

The NFPA 262 “Steiner Tunnel” Flame Test (formerly UL 910) measures flame spread and smoke generation in a simulated air handling plenum. A 25-foot long Steiner Tunnel is used for the test, with intake and exhaust ducts and a means of regulating flow velocity of air through the tunnel. Windows at 1-foot intervals allow for flame spread measurements, and an optical device in the exhaust of the chamber measures smoke density. The cable samples are mounted in a cable tray in one layer in the tunnel and the tunnel is sealed. Two circular burners are mounted vertically at the intake end of the tunnel just in front of the cable tray. Methane is burned, along with a 240 ft./min. forced draft through the tunnel for twenty minutes, and the flame is extinguished. Flame spread and smoke density are monitored throughout the test. A cable is listed for plenum use if flame spread is less than 5 feet from the end of the ignition flame, and optical density is less than 0.5 maximum peak, and 0.15 maximum average. The output of the burner is 300,000 Btu/hr and the energy consumed for the test is 100,000 Btus. The Canadian version of this test is known as the CSA FT6 fire test.

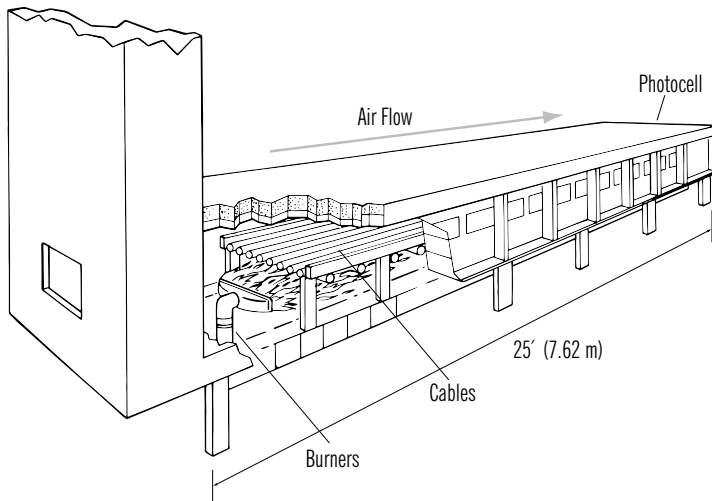

Figure 11.1—NFPA Steiner Tunnel Flame Test

### 11.2.5 UL 1666 Riser Flame Test

The Riser Flame Test, as described in Underwriters Laboratories Standard 1666, was developed to test cable flammability in riser applications. This test simulates a fire in a nonflame stopped riser within a high-rise building. The chamber for the test is a three-story block construction design. Steel fire doors provide access to the second and third levels for installing cables, and 1-foot x 2-foot rectangular holes in both the second and third level floors allow cable to be installed in racks extending between the first and third levels. A burner is made up of a 1/4 in. gas pipe with 90 degree elbow mounted below a 1-foot square drilled steel plate. The burner is mounted on the edge of the riser hole on the floor of the second level. A mixture of air and propane is burned for thirty minutes and then shut off, extinguishing the burner flame. A cable may be listed as riser cable if the flame does not propagate up to the floor of the third level. The energy output of the burner is 527,500 Btu/hr, or a consumed test energy of 263,750 Btus.

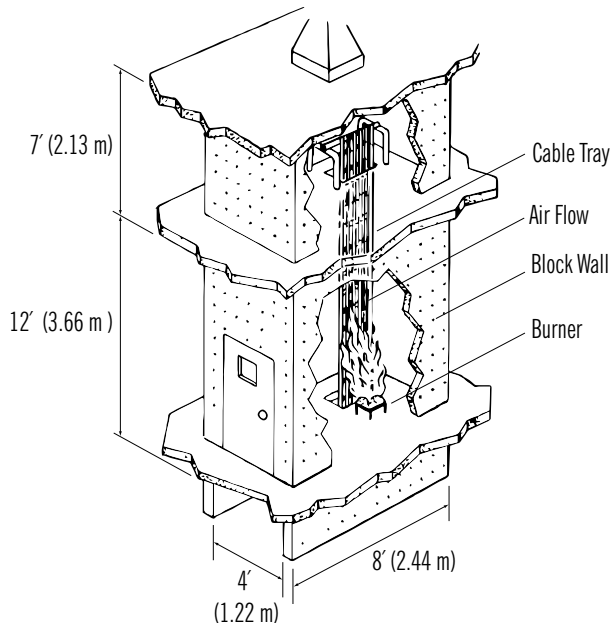

Figure 11.2—UL 1666 Riser Flame Test

### 11.2.6 UL 1685 Vertical Tray Flame Test

The Vertical Tray Flame Test is used as a good approximation of flame spread in cables run in groups. A steel ladder type tray 12 inches wide x 3 inches deep and 8 feet long with 1-inch x 1/2-inch rungs spaced 9 inches apart is mounted vertically on the floor of the test chamber. The center 6 inches of the tray is filled with cable samples in one layer spaced 1/2 cable diameter apart. A 6 to 1 mixture of air to propane is burned using a 10-inch wide ribbon burner. The burner is placed horizontally 3 inches from the back of the tray, 2 feet from the floor and midway between two rungs. The flame is applied for twenty minutes and then removed. A cable passes the vertical tray test if it does not propagate flame to the top of the tray (6 ft.). A cable may continue to burn after the burner is shut off; however, the test is not complete until the cable stops burning. The energy output of the burner is 70,000 Btu/hr and the cable is subjected to 23,333 Btus for the test. The 1685 standard also includes the CSA FT4/IEEE 1202 Flame Test. The UL 1685 test was formerly in the UL 1581 standard.

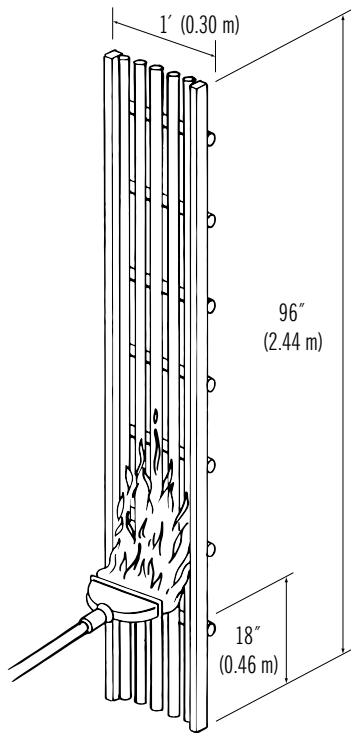

Figure 11.3—UL Vertical Tray Flame Test

### 11.2.7 ICEA T-29-520

A variation on the UL 1581 (UL 1685) Vertical Tray Test is the 210,000 Btu flame test specified in ICEA Standard T-29-520. In the 210,000 Btu test, the setup is essentially the same as with the 70,000 Btu test except the gas flow is increased to generate 210,000 Btu/hr instead of 70,000 Btu/hr of flame energy and the burner-to-cable spacing is increased to 200 millimeters. See [Section 11.2.3](#) for more details. This test method appears to be losing favor in the industry. IEEE 1202 or CSA FT4 are often used instead.



### 11.2.8 UL VW-1 (Vertical-Specimen) Flame Test

The VW-1 Flame Test was the first flame test developed for studying flame spread on wire and cable. The test measures relative flame propagation of a single wire or cable. The test procedure was formerly detailed in Underwriters Laboratories Standard 1581, but is now in UL 2556. A general overview of the test is as follows. The fixture used is a bench-mountable 12-inch wide, 14-inch deep and 24-inch high steel box open at the front and top. Clamps hold a single specimen vertically in the center of the box. A Tirrill burner (similar to a Bunsen burner) is mounted on a 20-degree angle block and has a flame 4 to 5 inches high with a 1/2-inch inner blue cone. The burner is placed so the inner cone meets the test sample surface. Ten inches above this point a kraft paper “flag” is placed on the sample facing away from the burner, and cotton batting covers the floor of the chamber to a height 9 inches below the point. The flame is applied to the sample for 15 seconds five times (total 75 seconds) with a minimum 15 seconds between flame applications or until burning ceases, whichever is longer. A sample passes VW-1 if less than 25 percent of the flag is burned away, the cable doesn’t burn longer than 60 seconds after any flame application, and the cotton batting is not ignited by dripping particles. The energy output of the burner is less than 3,000 Btu/hr and the test energy is less than 65 Btus. The VW-1 test is very similar to CSA’s FT1 flame test.

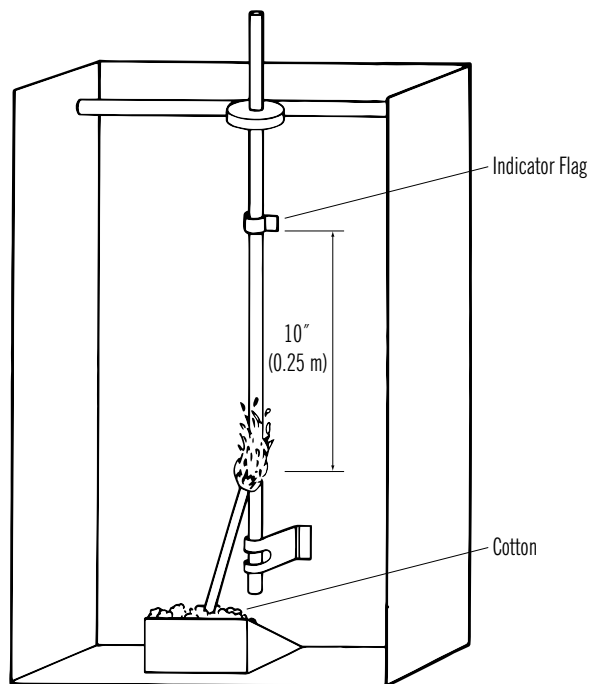

Figure 11.4—UL VW-1 (Vertical Specimen) Flame Test (formerly UL 1581 VW-1 Flame Test)

## 11.3 REGULATORY AND APPROVAL AGENCIES

### 11.3.1 Underwriters Laboratories

Table 11.4—Summary of Wire and Cable Types Covered by UL Standards

	UL Standard	UL Listing(s) Covered in the Standard
4	Armored Cable	AC
13	Power-Limited Circuit Cable	CL3P, CL2P, CL3R, CL2R, CL3, CL2, PLTC
44	Rubber Insulated Wires & Cables	XHHW, RHH, RHW, RH, SIS, RHW-2, XHHW-2
62	Flexible Cord & Fixture Wire	TFN, TFFN, TPT, TST, TS, S, SA, SE, SO, SEO, SOO, ST, STO, STOO, STOW, STOOO
83	Thermoplastic Insulated Wires	THW, THHN, THNN, FEP, FEPB, TFE, THW-2, THWN-2, Z, ZW
444	Communication Cables	CMP, CMR, CM, CMX
493	Thermoplastic Insulated Underground Feeder & Branch Circuit Cables	UF
719	Nonmetallic-Sheath Cables	NM, NMC
758	Appliance Wiring Material	AWM and all UL “Styles”
814	Gas-Tube-Sign Cable	GTO-5, GTO-10, GTO-15
854	Service-Entrance Cables	USE, SE, USE-2
1063	Machine-Tool Wires & Cables	MTW
1072	Medium Voltage Power Cable	MV
1276	Welding Cable	WELDING CABLE
1277	Electrical Power & Control Tray Cables with Optional Optical-Fiber Members	TC
1426	Electrical Cables for Boats	Boat Cable
1569	Metal Clad Cables	MC
1581	Reference Standard for Electrical Wires, Cables, and Flexible Cords	—
1650	Portable Power Cables	W, G, G-GC, PPE

Typical examples of UL’s mark appear below:



Figure 11.5—Typical UL Marks

### 11.3.2 National Electrical Code (NEC)

#### History and Articles

The first NEC document was written in 1897 at the insistence of various insurance, electrical, architectural and other interested parties. Up to and including 2008, there have been a total of 51 editions. It is revised on a regular three-year schedule. The National Electrical Code is divided into approximately 120 articles.

The Code is published by the National Fire Protection Association (NFPA) as a “recommended standard” and does not become law until it is officially adopted by state or local governments. Enforcement and interpretation of the Code is ultimately the responsibility of “the authority having jurisdiction,” (AHJ) i.e., the local inspector.

The intent of the Code is to ensure the electrical and fire safety of electrical equipment. It does not attempt to ensure the reliability, performance, proper operation or long life of equipment – these considerations are beyond its scope.

National Electrical Code Articles related to the wire and cable industry include:

Article 100	Definitions
Article 110	Requirements for Electrical Installations
Article 200	Use and Identification of Grounded Conductors
Article 210	Branch Circuits
Article 215	Feeders
Article 220	Branch-Circuit, Feeder and Service Calculations
Article 225	Outside Branch Circuits and Feeders
Article 230	Services
Article 250	Grounding and Bonding
Article 300	Wiring Methods
Article 310	Conductors for General Wiring
Article 310.15	Ampacities for Conductors Rated 0–2000 Volts
Article 310.60 (B)	Ampacities of Conductors Rated 2001 to 35,000 Volts
Article 320	Armored Cable: Type AC
Article 324	Flat Conductor Cable: Type FCC
Article 328	Medium Voltage Cable: Type MV
Article 330	Metal-Clad Cable: Type MC
Article 332	Mineral-Insulated, Metal-Sheathed Cable: Type MI
Article 334	Nonmetallic Sheathed Cable Types NM, NMC and NMS
Article 336	Power and Control Tray Cable: Type TC
Article 338	Service-Entrance Cable: Types SE and USE
Article 340	Underground Feeder and Branch-Circuit Cable: Type UF
Article 344	Rigid Metal Conduit: Type RMC
Article 350	Liquid-Tight, Flexible Metal Conduit: Type LFMC
Article 356	Liquid-Tight, Flexible Nonmetallic Conduit Type: LFMC
Article 358	Electrical Metallic Tubing: Type EMT
Article 362	Electrical Nonmetallic Tubing: Type ENT
Article 392	Cable Trays
Article 396	Messenger Supported Wiring
Article 400	Flexible Cords and Cables

Continued >>

**11.3.2 National Electrical Code (NEC) (Continued)**

Article 402	Fixture Wires
Article 409	Industrial Control Panels
Article 500	Hazardous (Classified) Locations, Classes I, II, and III, Divisions 1 and 2
Article 501	Class I Locations
Article 502	Class II Locations
Article 503	Class III Locations
Article 504	Intrinsically Safe Systems
Article 505	Class I, Zone 0, 1, and 2 Locations
Article 590	Temporary Installations
Article 604	Manufactured Wiring Systems
Article 610	Cranes and Hoists
Article 645	Information Technology Equipment
Article 690	Solar Photovoltaic (PV) Systems
Article 694	Small Wind Electric Systems
Article 725	Class 1, Class 2, Class 3, Remote-Control, Signaling and Power-Limited Circuits
Article 727	Instrumentation Tray Cable: Type ITC
Article 760	Fire Alarm Systems
Article 770	Optical Fiber Cables and Raceways
Article 800	Communication Circuits
Article 820	Community Antenna Television (CATV) and Radio Distribution Systems
Article 830	Network-Powered Broadband Communication Systems
Article 840	Premises-Powered Broadband Communications Systems
Chapter 9	Tables (Conduit fill, conductor properties, etc.)















**Table 11.5—NEC Article 725 – Summary of Remote Control, Signaling and Power-Limited Circuit Types**

Circuit Type	Circuit Voltage	Maximum Current
<b>Class 1 Remote Control and Signaling</b> (Not Power-Limited)	0 through 600	Unlimited
<b>Class 1 Power-Limited</b>	0 through 30	33 amps
<b>Class 2 Power-Limited</b> (Fire and Shock Safe)	0 through 30 30 through 150	8 amps 0.005 amps
<b>Class 3 Power-Limited</b> (Fire Safe Only)	30 through 150	10 amps

Note: The above is a highly simplified overview only. See Article 725 of the NEC for complete requirements. Class 2 cables must be rated at least 150 volts and Class 3 cables must be rated at least 300 volts, but may not be so marked.

## 11.3.3 International

Table 11.6—Symbols of International Organizations

Agency	Country(ies) Represented	Symbol
CSA (Canadian Standards Association)	Canada	
CEBEC (Comite Electrotechnique Belge Service de la Marque)	Belgium	
DEMKO (Danmarks Elektriske Materailkontrol)	Denmark	
SETI (Electrical Inspectorate Sakiniementie)	Finland	
CENELEC (European Committee for Electrotechnical Standards)	See Note 1.	
IEC (International Electrotechnical Commission)	More than 60 around the world	
ISO (International Standards Organization)	More than 60 around the world	
IMQ (Istituto Italiano del Marchio di Qualità)	Italy	
KEMA, KEUR (NV tot Keuring van Elektrotechnische Materialen)	Netherlands	
NEMKO (Norges Elektriske Materailknotroll)	Norway	
SEMKO (Svenska Electriska Materielkontrollanstalten)	Sweden	
SEV (Schweizerischen Electrotechnischen Verein)	Switzerland	
UL (Underwriters Laboratories)	USA	
UTE (Union Technique de L'Électricité)	France	
VDE (Verband Deutscher Elektrotechnischer)	Germany	

## Note 1:

Austria	Estonia	Iceland	Malta	Slovakia
Belgium	Finland	Ireland	Netherlands	Slovenia
Bulgaria	France	Italy	Norway	Spain
Cyprus	Germany	Latvia	Poland	Sweden
Czech Republic	Greece	Lithuania	Portugal	Switzerland
Denmark	Hungary	Luxembourg	Romania	United Kingdom



# 12. CONTINENTAL EUROPE

<b>12.1</b>	<b>European Union (EU) Standards</b>	<b>189</b>
	12.1.1 CENELEC	189
	12.1.2 CENELEC Cable Identification	191
	12.1.3 CENELEC Color Codes	193
	12.1.4 CENELEC Copper Conductors	193
	12.1.5 CEN	196
	12.1.6 Supply Voltages and Plug Configurations	196
<b>12.2</b>	<b>Austrian Standards</b>	<b>197</b>
	12.2.1 ÖVE	197
	12.2.2 Supply Voltage and Plug Configuration	197
<b>12.3</b>	<b>Belgian Standards</b>	<b>198</b>
	12.3.1 CEBEC	198
	12.3.2 NBN	198
	12.3.3 Supply Voltages and Plug Configurations	198
<b>12.4</b>	<b>Danish Standards</b>	<b>199</b>
	12.4.1 DEMKO	199
	12.4.2 Supply Voltage and Plug Configuration	199
<b>12.9</b>	<b>Dutch Standards</b>	<b>199</b>
	12.9.1 KEMA	199
	12.9.2 NEC	199
	12.9.3 Supply Voltage and Plug Configurations	199
<b>12.5</b>	<b>French Standards</b>	<b>200</b>
	12.5.1 UTE	200
	12.5.2 AFNOR	200
	12.5.3 CIGRE	200
	12.5.4 Supply Voltages and Plug Configurations	200
<b>12.6</b>	<b>German Standards</b>	<b>202</b>
	12.6.1 DIN	202
	12.6.2 VDE	203
	12.6.3 DKE	204
	12.6.4 Supply Voltages and Plug Configurations	204

# 12. CONTINENTAL EUROPE

<b>12.7</b>	<b>Irish Standards</b>	<b>204</b>
12.7.1	NSAI	204
12.7.2	Supply Voltage and Plug Configurations	204
<b>12.8</b>	<b>Italian Standards</b>	<b>205</b>
12.8.1	IMQ	205
12.8.2	CEI	205
12.8.3	CESI	205
12.8.4	Supply Voltage and Plug Configurations	205
<b>12.10</b>	<b>Norwegian Standards</b>	<b>206</b>
12.10.1	NEMKO	206
12.10.2	NPT	206
12.10.3	Supply Voltage and Plug Configurations	206
<b>12.11</b>	<b>Portuguese Standards</b>	<b>207</b>
12.11.1	IPQ	207
12.11.2	Supply Voltage and Plug Configurations	207
<b>12.12</b>	<b>Spanish Standards</b>	<b>208</b>
12.12.1	AENOR	208
12.12.2	Supply Voltages and Plug Configurations	208
<b>12.13</b>	<b>Swedish Standards</b>	<b>209</b>
12.13.1	SEMKO	209
12.13.2	ITS	209
12.13.3	Supply Voltage and Plug Configurations	209
<b>12.14</b>	<b>Swiss Standards</b>	<b>210</b>
12.14.1	SNV	210
12.14.2	ESTI	210
12.14.3	Supply Voltage and Plug Configurations	210



## 12.1 EUROPEAN UNION (EU) STANDARDS

### 12.1.1 CENELEC

European Committee for Electrotechnical Standardization

[www.cenelec.org](http://www.cenelec.org)

Document No.	Title
EN 50143	Cables for Signs and Luminous-Discharge-Tube Installations Rated 1 through 10 kV
EN 50173	Information Technology-Generic Cabling Systems
EN 50214	Flat PVC Sheathed Flexible Cables
EN 50395	Electrical Test Methods for Low Voltage Cables
EN 50396	Non-electrical Test methods for Low Voltage Cables
EN 60079-11	Intrinsically Safe Electrical Apparatus for Explosive Atmospheres
EN 60079-14	Electrical Apparatus for Explosive Gas Atmospheres
EN 60228	Conductors of Insulated Cables
EN 61138	Cables for Portable Earthing and Short-Circuiting Equipment
HD 21	PVC Insulated Cables of Rated Voltages up to and Including 450/750 V
HD 22	Rubber Insulated Cables of Rated Voltages Up To and Including 450/750 V
HD 308	Identification and Use of Cores of Flexible Cables
HD 359	Flat PVC Sheathed Cables for Lifts and Similar Applications
HD 505	Test Methods for Insulating and Sheathing Materials of Electric Cables
HD 586	Mineral Insulated Cables with Rated Voltage Not Exceeding 750 V
HD 603	Distribution Cables of Rated Voltage 0.6/1 kV
HD 604	0.6/1 kV Power Cables with Special Fire Performance for Use in Power Stations

CENELEC has adopted common standards for the European community. CENELEC adopts existing IEC standards whenever possible. As a result, HD 21 and HD 22 CENELEC documents are based on relevant IEC specifications. The member countries adopt these standards without any fundamental changes. Each country's testing authority can do its own testing for a manufacturer to obtain HAR (Harmonized) approval. Additional information is available at [www.eepca.org](http://www.eepca.org).

The countries in [Table 12.1](#) are CENELEC members that recognize the HAR mark. When wire and cable is manufactured in a CENELEC country and is marked with the HAR approval on the jacket, it may be used interchangeably in the member countries.

The HAR identification mark is applied along with the marks of origin and testing authority, to at least one conductor or the outer jacket. For example, Siemens products are marked: SIEMENS <VDE> <HAR>. In addition, there are country identification threads that are colored black, red and yellow. The different lengths of the colors indicate the nationality of the testing authority. For example, black 3 cm (1.2 inches) long, red 1 cm (0.4 inches) long, and yellow 1 cm (0.4 inches) long, indicates Germany.

Table 12.1—CENELEC Harmonized Approvals in the European Union

Member Country	Licensing Body/ Certification Agency	Imprint or Embossing on Jacket or Insulation	Black		Red		Yellow	
			in.	cm	in.	cm	in.	cm
Austria	Österreichischer Verband für Elektrotechnik (ÖVE)	<ÖVE> <HAR>	1.181	3	0.394	1	1.969	5
Belgium	Comité Electrotechnique Belge (CEBEC)	CEBEC <HAR>	0.394	1	1.181	3	0.394	1
Denmark	Danmarks Elektriske Materielkontroll	<DEMKO> <HAR>	1.181	3	0.394	1	1.181	3
France	Union Technique de l'Electricité (UTE)	UTE <HAR>	1.181	3	1.181	3	0.394	1
Germany	Verband Deutscher Elektrotechniker (VDE)	<VDE> <HAR>	1.181	3	0.394	1	0.394	1
Ireland	National Standards Authority of Ireland (NSAI)	<IIRS> <HAR>	1.181	3	1.181	3	1.969	5
Italy	Istituto Italiano del Marchio de Qualita (IMQ)	IMQ <HAR>	0.394	1	1.181	3	1.969	5
Netherlands	N.V. tot Keuring van Elektrotechnische Materialen (KEMA)	KEMA <HAR>	0.394	1	1.181	3	1.181	3
Norway	Norges Elektriske Materiekkontroll (NEMKO)	<NEMKO> <HAR>	0.394	1	0.394	1	2.756	7
Spain	Asociación Electrotécnica y Electrónica Española (AEE)	<UNE> <HAR>	1.181	3	0.394	1	2.756	7
Sweden	Svenska Elektriska Materielkontrollanstalter (SEMKO)	<SEMKO> <HAR>	0.394	1	0.394	1	1.963	5
United Kingdom	British Approvals Service for Cables	BASEC <HAR>	0.394	1	0.394	1	1.181	3

## 12.1.2 CENELEC Cable Identification

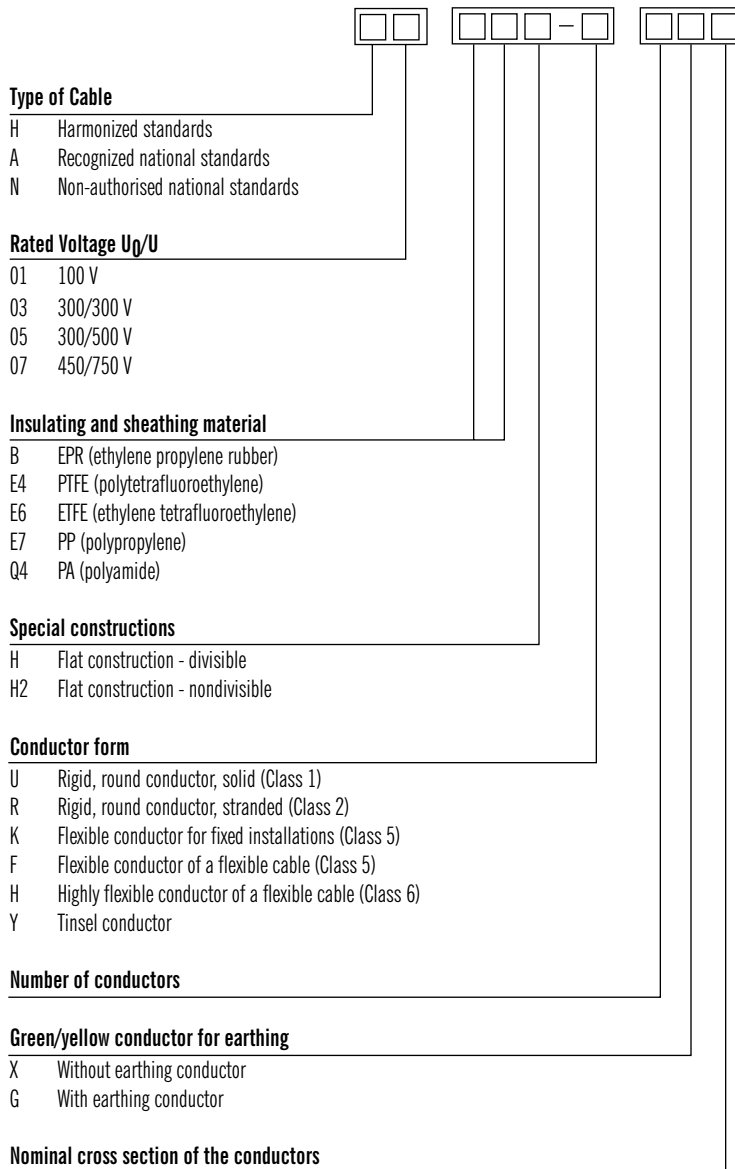

Figure 12.1—CENELEC Cable Identification Code

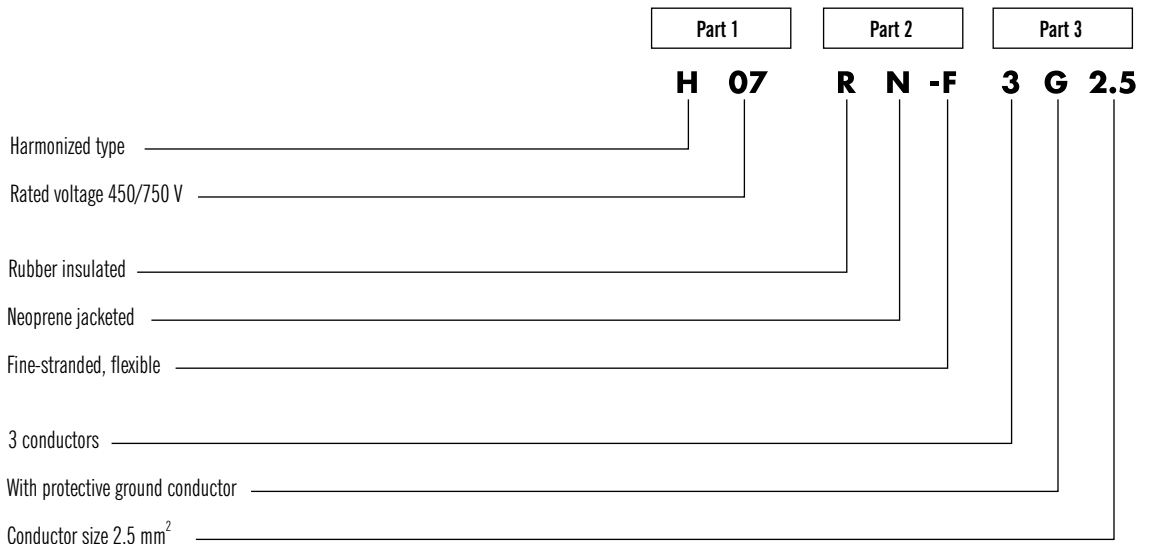

Figure 12.2—Example of a CENELEC Cable Identification Code

Below are CENELEC identification codes for some common cable types:

**Cenelec Harmonized ID Code**

H03VH-H	PVC Flexible Figure “8” Cable
H03VV-F2	PVC/PVC Flexible Mains Cable, 300 V, 2 Core
H03VV-F3	PVC/PVC Flexible Mains Cable, 300 V, 3 Core
H03VWH2-F2	PVC/PVC Flexible Mains Cable, 300 V, 2 Core Oval
H05RR-F2	Rubber/Rubber Flexible Mains Cable, 300/500 V, 2 Core
H05RR-F3	Rubber/Rubber Flexible Mains Cable, 300/500 V, 3 Core
H05RR-F4	Rubber/Rubber Flexible Mains Cable, 300/500 V, 4 Core
H05RR-F5	Rubber/Rubber Flexible Mains Cable, 300/500 V, 5 Core
H05V-U	PVC Single Conductor Building Wire, 450/750 V
H05VV-F2	PVC/PVC Flexible Mains Cable, 300/500 V, 2 Core
H05VV-F3	PVC/PVC Flexible Mains Cable, 300/500 V, 3 Core
H05VV-F4	PVC/PVC Flexible Mains Cable, 300/500 V, 4 Core
H05VV-F5	PVC/PVC Flexible Mains Cable, 300/500 V, 5 Core
H07V-K	PVC Appliance Wire, 450/750 V, Single Conductor
H07V-R	PVC Single Conductor Building Wire, 450/750 V
H07V-U	PVC Single Conductor Building Wire, 450/750 V, Solid Copper
H05VWH2-F	Flat Flexible Elevator Cable

### 12.1.3 CENELEC Color Codes

Through CENELEC, the EU countries have established the following color code for flexible cables as of 2006. “Green/yellow” indicates green insulation with a yellow stripe.

- **For cables WITHOUT a green/yellow earth conductor:**
  - 1 conductor All colors except yellow, green, white or grey
  - 2 conductor Brown and blue
  - 3 conductor Brown, black and grey
  - 4 conductor Blue, brown, black and grey
  - 5 conductor Blue, brown, black, grey and black
  - .5 conductors All conductors black with white numbers
- **For cables WITH a green/yellow earth conductor:**
  - 1 conductor All colors except yellow, green, white or grey
  - 2 conductor Not specified
  - 3 conductor Green/yellow, brown and blue
  - 4 conductor Green/yellow, brown, black and grey
  - 5 conductor Green/yellow, blue, brown, black and grey
  - .5 conductors One conductor green/yellow, others black with white numbers

Reference: CENELEC HD 308

### 12.1.4 CENELEC Copper Conductors

In the EU, the number of wires in a conductor (the fineness of the strand) is indicated by a numeral instead of by a letter as with the U.S. system. For example, a Class 6 conductor has more wires than a Class 5. [Tables 12.2](#) through [12.5](#) give the DC resistance for some common conductor sizes and stranding types. CENELEC standard EN 60228 contains additional information.

**Table 12.2—DC Resistance of Class 1 (Solid) Copper Conductors**

Nominal Conductor Size (mm <sup>2</sup> )	Minimum Number of Wires	Approximate Diameter of Wire (mm)	Maximum DC Resistance at 20°C (ohms/km)
1.5	1	1.38	12.10
2.5	1	1.78	7.41
4.0	1	2.25	4.61
6.0	1	2.76	3.08
10.0	1	3.57	1.83
16.0	1	4.50	1.15
25.0	1	5.65	0.727
35.0	1	6.60	0.524

Table 12.3—DC Resistance and Stranding of Class 2 Copper Conductors

Nominal Conductor Size (mm <sup>2</sup> )	Minimum Number of Wires		Maximum DC Resistance at 20°C (ohms/km)
	Circular	Compact Circular or Sector Shaped	
1.5	7	—	12.10
2.5	7	—	7.41
4.0	7	—	4.61
6.0	7	—	3.08
10.0	7	—	1.83
16.0	7	6	1.15
25.0	7	6	0.727
35.0	7	6	0.524
50.0	19	6	0.387
70.0	19	12	0.268
95.0	19	15	0.193
120.0	37	18	0.153
150.0	37	18	0.124
185.0	37	30	0.0991
240.0	61	34	0.0754
300.0	61	34	0.0601
400.0	61	53	0.0470
500.0	61	53	0.0366
630.0	91	53	0.0283
800.0	91	53	0.0221
1,000.0	91	53	0.0176

Table 12.4—DC Resistance and Stranding of Class 5 (Flexible) Copper Conductors

Nominal Conductor Size (mm <sup>2</sup> )	Maximum Diameter of Wires (mm)	Maximum DC Resistance at 20°C	
		Plain Copper (ohms/km)	Tinned Copper (ohms/km)
0.5	0.21	39.0	40.1
0.75	0.21	26.0	26.7
1.0	0.21	19.5	20.0
1.5	0.26	13.3	13.7
2.5	0.26	7.98	8.21
4.0	0.31	4.95	5.09
6.0	0.31	3.30	3.39
10.0	0.41	1.91	1.95
16.0	0.41	1.21	1.24
25.0	0.41	0.780	0.795
35.0	0.41	0.554	0.565
50.0	0.41	0.386	0.393
70.0	0.51	0.272	0.277
95.0	0.51	0.206	0.210
120.0	0.51	0.161	0.164
150.0	0.51	0.129	0.132
185.0	0.51	0.106	0.108
240.0	0.51	0.0801	0.0817
300.0	0.51	0.0641	0.0654
400.0	0.51	0.0486	0.0495
500.0	0.61	0.0384	0.0391

**Table 12.5—DC Resistance and Stranding of Class 6 (Highly Flexible) Copper Conductors**

Nominal Conductor Size (mm <sup>2</sup> )	Maximum Diameter of Wires (mm)	Maximum DC Resistance at 20°C	
		Plain Copper (ohms/km)	Tinned Copper (ohms/km)
0.5	0.16	39	40.1
0.75	0.16	26	26.7
1.0	0.16	19.5	20
1.5	0.16	13.3	13.7
2.5	0.16	7.98	8.21
4.0	0.16	4.95	5.09
6.0	0.21	3.30	3.39
10.0	0.21	1.91	1.95
16.0	0.21	1.21	1.24
25.0	0.21	0.780	0.795
35.0	0.21	0.554	0.565
50.0	0.31	0.386	0.393
70.0	0.31	0.272	0.277
95.0	0.31	0.206	0.210
120.0	0.31	0.161	0.164
150.0	0.31	0.129	0.132
185.0	0.31	0.106	0.108
240.0	0.31	0.0801	0.0817
300.0	0.31	0.0641	0.0654
400.0	0.51	0.0486	0.0495
500.0	0.61	0.0384	0.0391

**12.1.5 CEN**

European Committee for Standardization

[www.cen.eu](http://www.cen.eu)



**12.1.6 Supply Voltages and Plug Configurations**

**Table 12.6—EU Supply Voltages**

Frequency (Hz)	Voltage
50	220
50	250

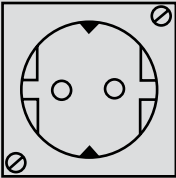
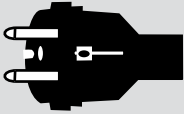
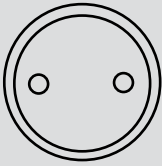

Table 12.7—EU Power Plug Configurations

Jack	Plug	Description
		“Schuko” European CEE 7
		Ungrounded Eurocord CEE 7/16

## 12.2 AUSTRIAN STANDARDS

### 12.2.1 ÖVE

Österreichischer Verband für Elektrotechnik

[www.ove.at](http://www.ove.at)



### 12.2.2 Supply Voltage and Plug Configuration

Table 12.8—Austrian Supply Voltage

Frequency (Hz)	Voltage
50	220/380

The neutral wire of the secondary distribution system is grounded. A grounding conductor is required in the electrical cord attached to appliances that are not double insulated.

Table 12.9—Austrian Plug Configuration

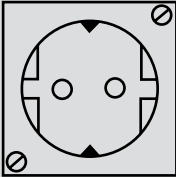
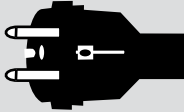
Jack	Plug	Description
		“Schuko” European CEE 7

## 12.3 BELGIAN STANDARDS

### 12.3.1 CEPEC

Comité Electrotechnique Belge  
www.cebec.sgs.com



### 12.3.2 NBN

Bureau de Normalisation  
www.nbn.be

Document No.	Title
NBN C 33-111	Armored Cables Insulated with Impregnated Paper for the Transmission and Distribution of Electrical Energy
NBN C 33-121	Armored, PVC Insulated Cables for the Transmission and Distribution of Electrical Energy
NBN C 33-211	Armored, Aluminum Conductor Cables Insulated with Impregnated Paper for 1, 6, 12, and 15 kV
NBN C 33-221	Power Cables
NBN C 33-321	Power Cables—Insulated Overhead Transmission Lines Rated 0.6/1 kV
NBN C 33-322	Underground Power Cables Rated 1 kV
NBN 759	Power Cables

### 12.3.3 Supply Voltages and Plug Configurations

Table 12.10—Belgian Supply Voltages

Frequency (Hz)	Voltage
50	127/220
50	220/380

The neutral wire of the secondary distribution system is grounded. A grounding conductor is required in the electrical cord attached to appliances.

Table 12.11—Belgian Plug Configurations

Jack	Plug	Description
		<p><b>Ungrounded Eurocord</b> CEE 7/16</p>
		<p><b>Belgium Socket</b> CEE 7/7 plug</p>

## 12.4 DANISH STANDARDS

### 12.4.1 DEMKO

Danmarks Elektriske Materielkontrol  
www.demko.dk





### 12.4.2 Supply Voltage and Plug Configuration

Table 12.12—Danish Supply Voltage

Frequency (Hz)	Voltage
50	220/380

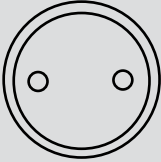
Table 12.13—Danish Plug Configuration

Jack	Plug	Description
		Ungrounded Eurocord CEE 7/16

## 12.9 DUTCH STANDARDS

### 12.9.1 KEMA

N.V. tot Keuring van Elektrotechnische Materialen  
www.kema.com



Document No.	Title
KEMA 157	Cables for temporary installations rated 450/750 kV
KEMA 149	Cross-linked polyethylene insulated, screened and PVC sheathed EMC cables rated 0.6/1 kV
KEMA 250	Screened flame retardant EMC cables with XLP insulation and halogen-free thermoplastic sheaths rated 0.6/1 kV

### 12.9.2 NEC

Netherlands Electro-Technical Committee  
www.nen.nl



### 12.9.3 Supply Voltage and Plug Configurations

Table 12.14—Dutch Supply Voltage

Frequency (Hz)	Voltage
50	220/380

The neutral wire of the secondary distribution system is grounded.

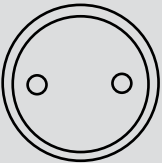
**Table 12.15—Dutch Plug Configurations**

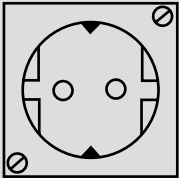
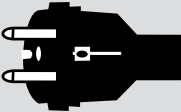
Jack	Plug	Description
		<b>Ungrounded Eurocord</b> CEE 7/16
		<b>“Schuko” European</b> CEE 7

## 12.5 FRENCH STANDARDS

### 12.5.1 UTE

Union Technique de l'Electricité

[www.ute-fr.com](http://www.ute-fr.com)

Document No.	Title
NF C32-207	Insulated Cables Covered with a Light PVC Sheath and Rated 300/500 V
NF C33-209	Bundle Assembled Cores for Overhead Systems Rated 0.6/1 kV

### 12.5.2 AFNOR

Association Française de Normalisation

[www.afnor.org](http://www.afnor.org)



### 12.5.3 CIGRE

Conference International des Grands Reseaux Electriques a Haute Tension





[www.cigre.org](http://www.cigre.org)

### 12.5.4 Supply Voltages and Plug Configurations

**Table 12.16—French Supply Voltages**

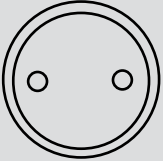
Frequency (Hz)	Voltage
50	220/230
50	127/220

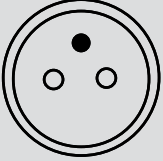
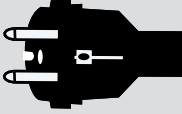
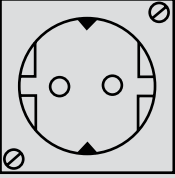
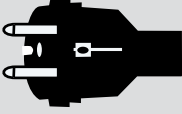
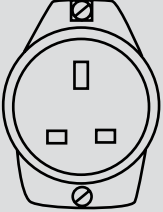
Table 12.17—French Plug Configurations

Jack	Plug	Description
		<p><b>Ungrounded Eurocord</b> CEE 7/16</p>
		<p><b>French Socket</b> CEE 7/7 plug</p>
		<p><b>“Schuko” European</b> CEE 7</p>
		<p><b>British Standard</b> BS 1363</p>

## 12.6 GERMAN STANDARDS

### 12.6.1 DIN

Deutsches Institut für Normung

www.din.de

Document No.	Title
VDE 0888 (EN 60793)	Optical Fibres—Measurement Methods and Test Procedures

Table 12.18—DIN 47100\* Color Code for Single Conductors (WITH Color Repetition Above 44)

Conductor No.		Color	Conductor No.		Color
1	45	White	23		White/Red
2	46	Brown	24		Brown/Red
3	47	Green	25		White/Black
4	48	Yellow	26		Brown/Black
5	49	Grey	27		Grey/Green
6	50	Pink	28		Yellow/Green
7	51	Blue	29		Pink/Green
8	52	Red	30		Yellow/Pink
9	53	Black	31		Green/Blue
10	54	Violet	32		Yellow/Blue
11	55	Grey/Pink	33		Green/Red
12	56	Red/Blue	34		Yellow/Red
13	57	White/Green	35		Green/Black
14	58	Brown/Green	36		Yellow/Black
15	59	White/Yellow	37		Grey/Blue
16	60	Yellow/Brown	38		Pink/Blue
17	61	White/Grey	39		Grey/Red
18		Grey/Brown	40		Pink/Red
19		White/Pink	41		Grey/Black
20		Pink/Brown	42		Pink/Black
21		White/Blue	43		Blue/Black
22		Brown/Blue	44		Red/Black

\* Standard withdrawn in 1998

Table 12.19—DIN 47100\* Color Code for Paired Conductors (WITH Color Repetition Above 22)

Pair No.			Wire A	Wire B
1	23	45	White	Brown
2	24	46	Green	Yellow
3	25	47	Grey	Pink
4	26	48	Blue	Red
5	27	49	Black	Violet
6	28	50	Grey/Pink	Red/Blue
7	29	51	White/Green	Brown/Green
8	30	52	White/Yellow	Yellow/Brown
9	31	53	White/Grey	Grey/Brown
10	32	54	White/Pink	Pink/Brown
11	33	55	White/Blue	Brown/Blue
12	34		White/Red	Brown/Red
13	35		White/Black	Brown/Black
14	36		Grey/Green	Yellow/Grey
15	37		Pink/Green	Yellow/Pink
16	38		Green/Blue	Yellow/Blue
17	39		Green/Red	Yellow/Red
18	40		Green/Black	Yellow/Black
19	41		Grey/Blue	Pink/Blue
20	42		Grey/Red	Pink/Red
21	43		Grey/Black	Pink/Black
22	44		Blue/Black	Red/Black

\* Standard withdrawn in 1998

**12.6.2 VDE****Verband Deutscher Elektrotechniker (German Electrotechnical Society)****www.vde-verlag.de**

Document No.	Title
0250	Insulated Power Cables
0265	Polymer Insulated Lead Sheathed Power Cables
0266	Power Cables with Improved Behavior in Case of Fire Rated 0.6/1 kV
0271	High voltage cable for special applications rated 0.6/1 kV
0281	Wire and cable for power circuits with thermoplastic insulation rated to 450/750 V
0282	Wire and cable for power circuits with rubber insulation rated to 450/750 V
0293	Identification of conductors in cables and flexible cords used in power installations rated up to 1,000 V
0295	Conductors of cables, wires and flexible cords
0472-815	Tests for halogen content of wires and cables

12.6.3 DKE

Deutsche Kommission Elektrotechnik Informationstechnik



www.dke.de

12.6.4 Supply Voltage and Plug Configurations

Table 12.20—German Supply Voltage

Frequency (Hz)	Voltage
50	220/380

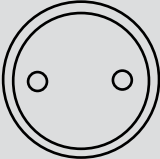
Table 12.21—German Plug Configurations

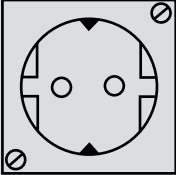
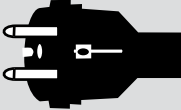
Jack	Plug	Description
		<p><b>Ungrounded Eurocord</b> CEE 7/16</p>
		<p><b>“Schuko” European</b> CEE 7</p>

12.7 IRISH STANDARDS

12.7.1 NSAI

National Standards Authority of Ireland

www.nsaie.ie



12.7.2 Supply Voltage and Plug Configurations

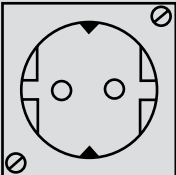
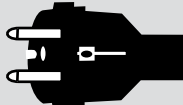
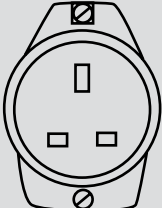

Table 12.22—Irish Supply Voltage

Frequency (Hz)	Voltage
50	220/380

The neutral wire of the secondary distribution system is grounded. A grounding conductor is required in the electrical cord attached to appliances.



Table 12.23—Irish Plug Configurations

Jack	Plug	Description
		<p><b>“Schuko” European</b> CEE 7</p>
		<p><b>British Standard</b> BS 1363</p>

## 12.8 ITALIAN STANDARDS

### 12.8.1 IMQ

Istituto Italiano del Marchio de Qualita

[www.imq.it](http://www.imq.it)

### 12.8.2 CEI

Comitato Elettrotecnico Italiano

[www.ceiweb.it](http://www.ceiweb.it)

### 12.8.3 CESI

Centro Elettrotecnico Sperimentale Italiano

[www.cesi.it](http://www.cesi.it)



### 12.8.4 Supply Voltage and Plug Configurations

Table 12.24—Italian Supply Voltage

Frequency (Hz)	Voltage
50	220/380

A grounding conductor is required in the electrical cord attached to appliances. The neutral wire of the secondary distribution system is grounded. Frequency tolerance: 62 percent; voltage tolerance: 610 percent.

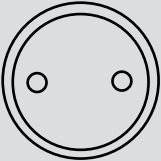
Table 12.25—Italian Plug Configurations

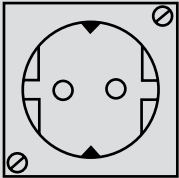
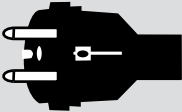
Jack	Plug	Description
		<p><b>Ungrounded Eurocord</b> CEE 7/16</p>
		<p><b>“Schuko” European</b> CEE 7</p>

## 12.10 NORWEGIAN STANDARDS

### 12.10.1 NEMKO

Norges Elektriske Materiekkontroll

[www.nemko.com](http://www.nemko.com)



### 12.10.2 NPT

Norwegian Post and Telecommunications Authority



[www.npt.no](http://www.npt.no)

### 12.10.3 Supply Voltage and Plug Configurations

Table 12.26—Norwegian Supply Voltage

Frequency (Hz)	Voltage
50	230

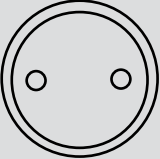
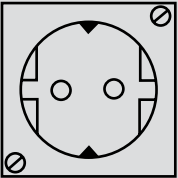
Table 12.27—Norwegian Plug Configurations

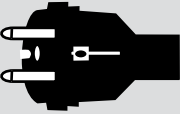
Jack	Plug	Description
 	 	<p data-bbox="964 335 1134 388"><b>Ungrounded Eurocord</b> CEE 7/16</p> <p data-bbox="964 569 1116 623"><b>“Schuko” European</b> CEE 7</p>

## 12.11 PORTUGUESE STANDARDS

### 12.11.1 IPQ

Instituto Portugues da Qualidade



[www.ipq.pt](http://www.ipq.pt)

### 12.11.2 Supply Voltage and Plug Configurations

Table 12.28—Portuguese Supply Voltage

Frequency (Hz)	Voltage
50	220/380

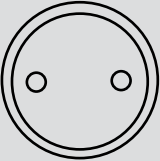
Table 12.29—Portuguese Plug Configurations

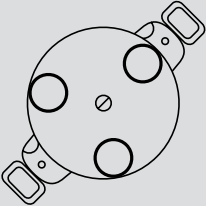
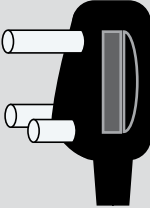
Jack	Plug	Description
		<b>Ungrounded Eurocord</b> CEE 7/16
		<b>Old British Standard</b> BS 546

## 12.12 SPANISH STANDARDS

12.12.1 AENOR  
Asociación Española de Normalización y Certificación  
[www.aenor.es](http://www.aenor.es)



Document No.	Title
UNE 20432	Tests on Electrical Cable Under Fire Conditions
UNE 21172	Measurement of Smoke Density of Electric Cable Burning in Defined Conditions



### 12.12.2 Supply Voltages and Plug Configurations

Table 12.30—Spanish Supply Voltage

Frequency (Hz)	Voltage
50	127/220
50	220/380

A grounding conductor is required for the 220/380 voltage.

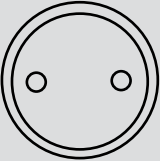
Table 12.31—Spanish Plug Configurations

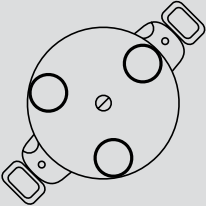
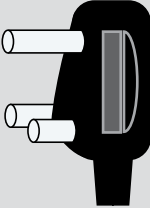
Jack	Plug	Description
		<b>Ungrounded Eurocord</b> CEE 7/16
		<b>Old British Standard</b> BS 546

## 12.13 SWEDISH STANDARDS

**12.13.1 SEMKO**  
Svenska Elektriska Materielkontrollanstalten  
[www.semko.se](http://www.semko.se)

**12.13.2 ITS**  
Informationstekniska Standardiseringen  
[www.its.se](http://www.its.se)

**12.13.3 Supply Voltage and Plug Configurations**

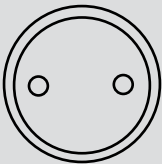

Table 12.32—Swedish Supply Voltage

Frequency (Hz)	Voltage
50	220/380

The neutral wire of the secondary distribution system is grounded. A grounding conductor is required in the electrical cord attached to appliances.

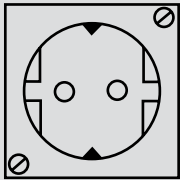
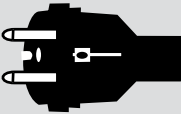

Table 12.33—Swedish Plug Configurations

Jack	Plug	Description
		<b>Ungrounded Eurocord</b> CEE 7/16
		<b>“Schuko” European</b> CEE 7

## 12.14 SWISS STANDARDS

12.14.1 SNV  
Schweizerische Normen-Vereinigung  
[www.snv.ch](http://www.snv.ch)

12.14.2 ESTI (formerly SEV)  
Eidgenössisches Starkstrominspektorat  
[www.esti.ch](http://www.esti.ch)

### 12.14.5 Supply Voltage and Plug Configurations

Table 12.34—Swiss Supply Voltage

Frequency (Hz)	Voltage
50	220/380

The neutral wire of the secondary distribution system is grounded. A grounding conductor is required in the electrical cord attached to appliances.

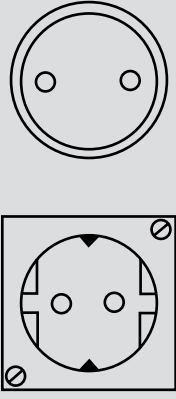
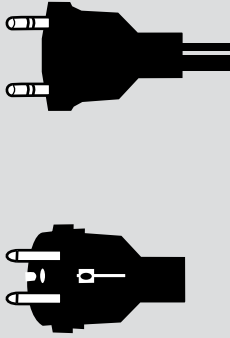

Table 12.35—Swiss Plug Configurations

Jack	Plug	Description
		<p data-bbox="974 329 1142 390"><b>Ungrounded Eurocord</b> CEE 7/16</p> <p data-bbox="974 564 1122 624"><b>“Schuko” European</b> CEE 7</p>





# 13. UNITED KINGDOM

<b>13.1</b>	<b>Standards</b>	<b>214</b>
13.1.1	BSI	214
13.1.2	BASEC	216
13.1.3	BBC	216
13.1.4	BNFL	216
13.1.5	BRB	216
13.1.6	British Telecom (BT Group)	216
13.1.7	Department of the Environment	217
13.1.8	Department for Transport	217
13.1.9	ERA Technology Ltd.	217
13.1.10	ENA	217
13.1.11	IET (Formerly IEE)	217
13.1.12	London Underground Limited	218
13.1.13	Ministry of Defense (MODUK)	218
13.1.14	Network Rail	218
13.1.15	RIA	218
<b>13.2</b>	<b>Supply Voltage and Plug Configurations</b>	<b>219</b>

## 13.1 STANDARDS

### 13.1.1 BSI

#### British Standards

[www.bsi-global.com](http://www.bsi-global.com)

Document No.	Title
BS 3G 210	PTFE insulated equipment wires with silver-plated conductors
BS 115	Metallic resistance materials for electric purposes
BS 183	General purpose galvanized steel wire strand
BS 215	Aluminum conductors and aluminum conductors, steel-reinforced, for overhead power transmission
BS 638-1	Welding cables
BS 1117	Bare fine resistance wire for precision electrical equipment
BS 2316	Radio frequency cables
BS 2627	Wrought aluminum wire for electrical purposes
BS 3573	Polyethylene-insulated copper conductor telecommunication distribution cables
BS 4393	Tin or tin-lead coated copper wire
BS 4553	PVC-insulated split concentric cables with copper conductors for electric supply
BS 4808	L.F. cables and wires with PVC insulation and PVC sheath for telecommunication
BS 5099	Spark testing of electric cables
BS 5308	Instrumentation cables
BS 5467	Specification for armored cables with thermosetting insulation for electricity supply
BS 6004	PVC-insulated cables for electric power and lighting
BS 6007	Single core heat resisting cables
BS 6141	Replaced by specifications BS 6500, BS 6004, BS 6007 and BS 7919
BS 6195	Insulated flexible cables and cords for coil leads
BS 6207	Mineral-insulated cables
BS 6231	PVC-insulated flexible cables for switchgear and controlgear wiring rated 600/1,000 V
BS 6500	Insulated flexible cords
BS 6708	Specification for trailing cables for mining purposes
BS 6724	Thermoset insulated, armored cables having low emission of smoke and corrosive gases
BS 6746C	Color chart for insulation and sheath of electric cables

Continued >>

## 13.1.1 BSI (Continued)

Document No.	Title
BS 6883	Elastomer insulated cable for fixed wiring in ships
BS 6899	Replaced by specification BS 7655
BS 6977	Replaced by specification BS EN 50214
BS 7655	Insulating and sheathing materials for cables
BS 7671	IEE Wiring Regulations
BS 7884	Copper and copper-cadmium conductors for overhead power transmission
BS 7919	Electric Cables-Flexible cables rated up to 450 V/750 V for use with appliances and equipment intended for industrial and similar environments
BS EN 10244-2	Zinc or zinc alloy coatings on steel wire
BS EN 10257	Galvanized steel wire for armoring land and submarine cables
BS EN 12166	Copper and copper alloys; wire for general purposes
BS EN 13601	Copper and copper alloys for electrical purposes; rod, bar and wire
BS EN 13602	Copper and copper alloys; drawn, round copper wire for electrical conductors
BS EN 50117	Specification for coaxial cables for wired distribution systems
BS EN 50143	Cables for signs and luminous-discharge-tube installations
BS EN 50149	Copper and copper alloy grooved contact wire for electric traction
BS EN 50183	Conductors for overhead lines: aluminum-magnesium-silicon alloy wires
BS EN 50189	Conductors for overhead lines: zinc coated steel wires
BS EN 50266	Test methods for cables under fire conditions; vertical flame spread
BS EN 50214	Flat Polyvinyl Chloride sheathed flexible cables
BS EN 50267	Test methods for cables under fire conditions; evolved gases
BS EN 60228	Conductors of insulated cables
BS EN 60332	Tests on electric and optical cables under fire conditions
BS EN 60811	Test methods for insulating and sheathing materials of electric cables
BS EN 61238	Mechanical and compression connectors for power cable
PD 6455	Cancelled

**13.1.2 BASEC**

**British Approvals Service for Cables**

[www.basec.org.uk](http://www.basec.org.uk)

BASEC is a product marking and certification agency similar to UL and CSA in North America.

**13.1.3 BBC**

**British Broadcasting Company**

[www.bbc.co.uk](http://www.bbc.co.uk)

Document No.	Title
PSF 1/2M	Video cable (similar to Belden 8281)
PSF 1/3M	Video cable
PSF 1/9M	Flexible camera cable
PSF 4/1M	Microphone cable

**13.1.4 BNFL**

**British Nuclear Fuels (inactive)**

Document No.	Title
PM73479	Cables for electricity supply and control having low emission of smoke and corrosive gases when affected by fire (see Section 13.1.1 “BS 6724” for additional information)

**13.1.5 BRB**

**British Railways Board**

[www.brbr.co.uk](http://www.brbr.co.uk) (inactive)

Document No.	Title
TDE/76/P/16	Single core cables for traction and rolling stock (cross-linked polyolefin types)

**13.1.6 British Telecom (BT Group)**

[www.btplc.com](http://www.btplc.com)

Document No.	Title
CW1109	Single, twin and triple jumper wire for electronic equipment
CW1128	Polyethylene insulated and sheathed, jelly-filled, twisted-pair telephone cable for outdoor use (up to and including 100 pairs)
CW1198	External telephone cable
CW1229	Coaxial cable
CW1236	Polyethylene insulated and sheathed, jelly-filled, twisted-pair telephone cable for outdoor use (above 100 pairs)
CW1252	Self-supporting aerial telephone cable
CW1257	Jumper wire
CW1293	Internal telephone cable
CW1308	PVC-insulated and sheathed telephone cable for indoor use
CW1311	Telephone cordage
CW1316	Undercarpet telephone cable
CW1378	Drop wire no. 10
CW1600	“LFH” insulated and sheathed telephone cable for indoor use

**13.1.7 Department of the Environment**[www.doeni.gov.uk](http://www.doeni.gov.uk)

Document No.	Title
M&E 42	Aviation ground lighting. Single core 6 mm <sup>2</sup> (2,000 V) PVC-sheathed cable

**13.1.8 Department for Transport**[www.dft.gov.uk](http://www.dft.gov.uk)

Document No.	Title
TR 1173	Multipair communications cable, polyethylene-insulated, polyethylene-sheathed, armored
TR 1238	Power cable for motorway communication systems (split concentric, armored)
TR 2029	Inductive loop cable for vehicle detection systems

**13.1.9 ERA Technology Ltd.**[www.era.co.uk](http://www.era.co.uk)

Document No.	Title
ERA 69-30 Part I	Sustained current ratings for paper-insulated, lead-sheathed cables
ERA 69-30 Part III	Sustained current ratings for PVC insulated cables
ERA 69-30 Part V	Sustained current ratings for cables with thermosetting insulation
ERA 93-0233R	User's guide to power cable fault location
ERA 98-0668	Cabling installations: user friendly guide (EMI separation recommendations)

**13.1.10 ENA**[www.energynetworks.org](http://www.energynetworks.org)

Document No.	Title
09-6	Auxiliary multicore and multipair cables
09-7	PVC-insulated concentric service cables with stranded copper conductors and copper concentric conductors
09-8	Impregnated paper insulated 600/1,000 V cable with three solid aluminum phase conductors and aluminum sheath/neutral conductor (CONSAC)
09-12	Impregnated paper insulated corrugated aluminum sheathed 6,350/11,000 V cable (PICAS)
43-13	Aerial bundled conductors (ABC) insulated with cross-linked polyethylene for low voltage overhead distribution

**13.1.11 IET (formerly IEE)**[www.theiet.org](http://www.theiet.org)

Document No.	Title
BS7671	IEE Wiring Regulations

**13.1.12 London Underground Limited**[www.tfl.gov.uk/tube](http://www.tfl.gov.uk/tube)

Document No.	Title
G4727	2, 3 and 4 core SWA cable low voltage, limited fire hazard (low smoke nonhalogenated), 2.5 mm <sup>2</sup> to 300 mm <sup>2</sup>
G4726	Single core cable insulated nonsheathed, limited fire hazard (low smoke nonhalogenated), 1.5 mm <sup>2</sup> to 300 mm <sup>2</sup>
RSE/STD/024 part 6	Cables for use on rolling stock ("LFIL" types)

**13.1.13 Ministry of Defense (MODUK)****British Defense Standards**[www.dstan.mod.uk](http://www.dstan.mod.uk)

Document No.	Title
DEF STAN 02-525	Requirements for electric cables, thin-wall insulated, limited fire hazard
DEF STAN 02-526	Requirements for cables, electric, rubber insulated, limited fire hazard, sheathed for general services
DEF STAN 02-527	Requirements for cables, electric, fire survival, high temperature zones and limited fire hazard, sheathed
DEF STAN 02-711	Determination of the smoke index of the products of combustion
DEF STAN 02-713	Determination of the toxicity index of the products of combustion
DEF STAN 61-12 part 1	Cables, electrical (insulated flexible cords and flexible cables)
DEF STAN 61-12 part 2	Cables, electrical (for power and lighting)
DEF STAN 61-12 part 4	Cables, special purpose, electrical (subminiature electric cables)
DEF STAN 61-12 part 5	Cables, special purpose, electrical, and cables, power, electrical (small multicore cables)
DEF STAN 61-12 part 6	Polyvinyl chloride (PVC), polyethylene, or silicone rubber insulated equipment wires
DEF STAN 61-12 part 8	PTFE insulated equipment wire
DEF STAN 61-12 part 9	Cables, radio frequency (coaxial)
DEF STAN 61-12 part 18	Equipment wires, low toxicity
DEF STAN 61-12 part 25	Cables, electrical, limited fire hazard, up to conductor size 2.5 mm <sup>2</sup>

**13.1.14 Network Rail**[www.networkrail.co.uk](http://www.networkrail.co.uk)

Document No.	Title
NR/PS/SIG/00005	Flame retardant compound insulated cables for railway signalling

**13.1.15 RIA****Railway Industry Association**[www.riagh.org.uk](http://www.riagh.org.uk)



Document No.	Title
NBRB/RIA 10	Twin and multicore jumper cables for diesel and electric vehicles
BRB/LUL/RIA 21	Single-core cables for installation on traction and rolling stock (rubber types)

## 13.2 SUPPLY VOLTAGE AND PLUG CONFIGURATIONS

Table 13.1 – United Kingdom Supply Voltage

Frequency (Hz)	Voltage
50	230/400

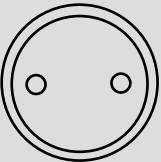
Table 13.2–United Kingdom Plug Configurations

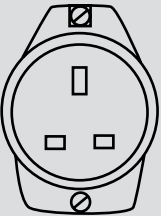
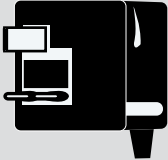
Jack	Plug	Description
		<b>Ungrounded Eurocord</b> CEE 7/16
		<b>British Standard</b> BS 1363





# 14. LATIN AND SOUTH AMERICA

<b>14.1</b>	<b>Mexican Standards</b>	<b>222</b>
14.1.1	ANCE	222
14.1.2	Supply Voltage and Plug Configuration	223
<b>14.2</b>	<b>Venezuelan Standards</b>	<b>223</b>
14.2.1	FONDONORMA	223
<b>14.3</b>	<b>Brazilian Standards</b>	<b>224</b>
14.3.1	ABNT	224
<b>14.4</b>	<b>Colombian Standards</b>	<b>224</b>
14.4.1	ICONTEC	224
<b>14.5</b>	<b>Argentine Standards</b>	<b>224</b>
14.5.1	IRAM	224

## 14.1 MEXICAN STANDARDS

### 14.1.1 ANCE

Asociación de Normalización y Certificación

[www.ance.org.mx](http://www.ance.org.mx)

Document No.	Title
NOM-001-SEDE	Mexican Code Standard for Electrical Installations
NMX-E-034-SCFI	Plastics Industry—Carbon Black Contents on Polyethylene Materials—Test Method
NMX-J-008-ANCE	Tinned Soft or Annealed Copper Wire for Electrical Purposes
NMX-J-010-ANCE	Conductors with Thermoplastic Insulation Rated 600 V
NMX-J-012-ANCE	Concentric Lay Stranded Copper Conductors for Electrical Purposes
NMX-J-013-ANCE	Rope Lay Stranded Copper Conductors Having Concentric Stranded Members for Electrical Purposes
NMX-J-014-ANCE	Rope Lay Stranded Copper Conductors Having Bunch Stranded Members for Electrical Purposes
NMX-J-032-ANCE	Concentric Lay Stranded Aluminum Cable for Electrical Purposes
NMX-J-036-ANCE	Soft or Annealed Copper Wire for Electrical Purposes
NMX-J-040-ANCE	Determination of Moisture Absorption in Insulations and Jackets of Electrical Conductors—Test Method
NMX-J-066-ANCE	Determination of Diameters of Electrical Conductors—Test Method
NMX-J-177-ANCE	Determination of Thickness in Semiconductive Shielding, Insulations, and Jackets of Electrical Conductors—Test Method
NMX-J-178-ANCE	Ultimate Strength and Elongation of Insulation, Semiconductive Shielding, and Jackets of Electrical Conductors—Test Method
NMX-J-186-ANCE	Accelerated Aging in Forced Air Convection Oven of Semiconducting Shields, Insulations and Jackets of Electrical Conductors—Test Method
NMX-J-190-ANCE	Thermal Shock Resistance of PVT Insulations and PVT Protective Coverings of Electrical Conductors—Test Method
NMX-J-191-ANCE	Heat Distortion of Semiconductive Shielding, Insulations and Protective Coverings of Electrical Conductors—Test Method
NMX-J-192-ANCE	Flame Test on Electrical Wires—Test Method
NMX-J-193-ANCE	Cold Bend of Thermoplastic Insulation and Protective Jackets, Used on Insulated Wire and Cable—Test Method
NMX-J-212-ANCE	Electrical Resistance, Resistivity and Conductivity—Test Method
NMX-J-294-ANCE	Insulation Resistance—Test Method
NMX-J-312-ANCE	Tensile Strength and Elongation by Strain of Wires for Electrical Conductors—Test Method
NMX-J-417-ANCE	Convection Laboratory Ovens for Evaluation of Electrical Insulation—Specifications and Test Methods
NMX-J-437-ANCE	Determination of Light Absorption Coefficient of Polyethylene Pigmented with Carbon Black—Test Method
NMX-J-451-ANCE	Power Cables with XLP or EP Insulation Rated 600 V
NMX-J-498-ANCE	Vertical Tray—Flame Test—Test Method
NMX-J-556-ANCE	Wire and Cable Test Methods

### 14.1.2 Supply Voltage and Plug Configuration

Table 14.1—Mexican Supply Voltages

Frequency (Hz)	Voltage
50	127/220

Table 14.2—Mexican Plug Configuration

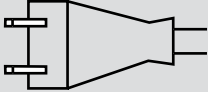
Jack	Plug	Description
		North American Ungrounded

## 14.2 VENEZUELAN STANDARDS

### 14.2.1 FONDONORMA

Fondo para la Normalización y Certificación de Calidad

[www.fondonorma.org.ve](http://www.fondonorma.org.ve) or [www.codelectra.org](http://www.codelectra.org)

Document No.	Title
0200	Venezuelan National Electrical Standard (Código Eléctrico Nacional) (Based on the U.S. National Electrical Code (NFPA 70))
0397	Wires and single-conductor cables with thermoplastic insulation
0457	Calculation of the permissible current in cables
0468	Sampling and methods of test to determine the cross-sectional area of conductors
0529	Bare copper cables. Specifications and methods test.
0530	Aluminum 1350/1370 for manufacture of electrical conductors
0533	Aluminum conductors 1350 with concentric stranding
0534	Conductors with twisted concentric aluminum layers, reinforced with steel
0541	Insulated wires and cables for distribution of electrical energy up to 2,000 V and control cables
0555	Compacted bare aluminum conductors for electrical use
0556	Round aluminum alloy 6201-T 81 wires for electrical use
0557	Conductors with aluminum alloy 6201 T-81 wires
0558	Flexible cords and wires
0777	Bare soft copper wires, rectangular
1110	Aluminum conductors with aluminum alloy reinforcement (ACAR)
2570	Wires and Cables. Determination of the level of extinction of partial discharges
2644	Compacted concentric round aluminum cables
2645	Round aluminum wire 1350, annealed and of intermediate tempers
3198	Multi-pair telephone cables for external plant
3484	Enameled coil wire

### 14.3 BRAZILIAN STANDARDS

---

#### 14.3.1 ABNT

Associação Brasileira De Normas Técnicas

[www.abnt.org.br](http://www.abnt.org.br)

Document No.	Title
NBR 5410	Low Voltage Electrical Installations
NBR 11301	Calculation of the Continuous Current Ratings of Cables at 100 percent load factor
NBR 14039	Installation of Electrical Systems Rated 1.0 kV to 36.2 kV

### 14.4 COLOMBIAN STANDARDS

---

#### 14.4.1 ICONTEC

Instituto Colombiano de Normas Técnicas

[www.icontec.org.co](http://www.icontec.org.co)

Document No.	Title
NTC 2050	Colombian National Electrical Standard (Based on the U.S. National Electrical Code (NFPA 70))

### 14.5 ARGENTINE STANDARDS

---

#### 14.5.1 IRAM

Instituto Argentino de Normalización y Certificación

[www.iram.com.ar](http://www.iram.com.ar)

Document No.	Title
NM 247	PVC Insulated Cables Rated up to 450/750 V
NM 274	Silicone Insulated Cables Rated up to 450/750 V
NM 280	Conductors of Insulated Cables
2214	Cathodic Protection Cables
62266	Power and Control Cables with Low Smoke Emission and No Halogen (LSZH) Rated 1 kV

# 15. CANADA

<b>15.1</b>	<b>Standards</b>	<b>226</b>
	15.1.1 CSA	226
	15.1.2 SCC	227
<b>15.2</b>	<b>Cable Types</b>	<b>228</b>
<b>15.3</b>	<b>Supply Voltage and Plug Configurations</b>	<b>231</b>
<b>15.4</b>	<b>Fire Ratings</b>	<b>232</b>
	15.4.1 “FT1” Fire Test	232
	15.4.2 “FT4” Fire Test	232
	15.4.3 “FT6” Fire Test	232
	15.4.4 Designations	232
<b>15.5</b>	<b>Single Conductor Teck 90 Terminations</b>	<b>233</b>

## 15.1 STANDARDS

### 15.1.1 CSA

#### Canadian Standards Association

[www.csa.ca](http://www.csa.ca) and [www.csa-international.org](http://www.csa-international.org)

Document No.	Title
C22.1	Canadian Electrical Code, Part I
C22.2 No. 0	General Requirements—Canadian Electrical Code, Part II
C22.2 No. 0.3	Test Methods for Electrical Wire and Cables
C22.2 No. 0.8	Safety Functions Incorporating Electronic Technology
C22.2 No. 0.12	Wiring Space and Wire Bending Space in Enclosures for Equipment Rated 750 V or Less
C22.2 No. 18	Outlet Boxes, Conduit Boxes and Fittings
C22.2 No. 21	Cord Sets and Power Supply Cords
C22.2 No. 26	Wireways, Auxiliary Gutters and Associated Fittings
C22.2 No. 35	Extra-Low-Voltage Control Circuit Cables, Low-Energy Control Cable and Extra-Low-Voltage Control Cable
C22.2 No. 38	Thermoset-Insulated Wires and Cables
C22.2 No. 41	Grounding and Bonding Equipment
C22.2 No. 42	General Use Receptacles, Attachment Plugs and Similar Wiring Devices
C22.2 No. 48	Nonmetallic Sheathed Cable
C22.2 No. 49	Flexible Cords and Cables
C22.2 No. 51	Armored Cables
C22.2 No. 52	Service-Entrance Cables
C22.2 No. 56	Flexible Metal Conduit and Liquid-Tight Flexible Metal Conduit
C22.2 No. 62	Surface Raceway Systems
C22.2 No. 65	Wire Connectors
C22.2 No. 75	Thermoplastic-Insulated Wires and Cables
C22.2 No. 96	Portable Power Cables
C22.2 No. 123	Aluminum-Sheathed Cables
C22.2 No. 124	Mineral-Insulated Cable
C22.2 No. 126	Cable Tray Systems
C22.2 No. 127	Equipment and Lead Wires
C22.2 No. 129	Neutral Supported Cable
C22.2 No. 130	Heat Cable Systems
C22.2 No. 131	Type TECK 90 Cable
C22.2 No. 138	Heat Tracing Cable and Cable Sets for Use in Hazardous Locations
C22.2 No. 174	Cables and Cable Glands for Use in Hazardous Locations
C22.2 No. 179	Airport Series Lighting Cables
C22.2 No. 188	Splicing Wire Connectors

Document No.	Title
C22.2 No. 197	PVC Insulating Tape
C22.2 No. 198	Sealed Wire Connector Systems
C22.2 No. 208	Fire Alarm and Signal Cable
C22.2 No. 210	Appliance Wiring Material Products
C22.2 No. 211	Non-Metallic Conduit
C22.2 No. 214	Communications Cables
C22.2 No. 222	Type FCC Under-Carpet Wiring Systems
C22.2 No. 230	Tray Cables
C22.2 No. 232	Optical Fiber Cables
C22.2 No. 239	Control and Instrumentation Cables
C22.2 No. 245	Marine Shipboard Cable
C22.2 No. 262	Optical Fiber Cable and Communications Cable
C22.2 No. 556	Wire and Cable Test Methods
C49.2	Compact Aluminum Conductors Steel Reinforced (ACSR)
C49.3	Aluminum Alloy 1350 Round Wire, All Tempers for Electrical Purposes
C49.5	Compact Round Concentric-Lay Aluminum-Stranded Conductors (Compact ASC)
C57	Electrical Power Connectors for use in Overhead Line Conductors
C68.1	Paper-Insulated Power Cable
C68.3	Concentric Neutral Power Cable Rated 5-45 kV
C83	Communication and Power Line Hardware
Z243	Information Processing Systems

### 15.1.2 SCC

#### Standards Council of Canada

[www.scc.ca](http://www.scc.ca)

Standardization is the development and application of standards — publications that establish accepted practices, technical requirements and terminologies for products, services and systems.

Standards help ensure better, safer and more efficient methods and products, and are an essential element of technology, innovation and trade.

The Standards Council carries out a variety of functions intended to ensure the effective and coordinated operation of standardization in Canada. It also represents Canada's interests on standards-related matters in foreign and international forums.

## 15.2 CABLE TYPES

Table 15.1—CSA Cable Types

Conditions of Use	Trade Designation	CSA Type Designation	Maximum Allowable Conductor Temperature °C
For exposed wiring in dry locations only	Armored cable	TECK 90	90
		AC90	90
For exposed wiring in dry locations where exposed to corrosive action, if suitable for corrosive conditions encountered	Armored cable	TECK 90	90
For exposed wiring in dry locations where not exposed to mechanical injury	Non-metallic-sheathed cable	NMD90	90
For exposed wiring in dry locations and in Category 1 and 2 locations, where not exposed to mechanical injury	Non-metallic-sheathed cable	NMW, NMWU	60
For exposed wiring in dry or damp locations	Rubber- (thermoset-) insulated cable	R90	90
	Thermoplastic-insulated cable	TW	60
	Nylon jacketed thermoplastic-insulated cable	T90 NYLON	90
	Non-metallic-sheathed cable	NMD90	90
For exposed wiring in wet locations	Armored cable	TECK90	90
		ACWU90	90
	Rubber- (thermoset-) insulated cable	RW75	75
		RL90, RW90	90
	Aluminum-sheathed cable	RA75	75
		RA90	90
	Mineral-insulated cable	MI, LWMI	90
	Thermoplastic-insulated cable	TW	60
		TW75, TWN75	75
	Nonmetallic-sheathed cable	NMWU	60
For exposed wiring where subjected to the weather	Armored cable	TECK90	90
	Rubber- (thermoset-) insulated cable	RW75	75
		R90, RW90	90
	Thermoplastic-insulated cable	TW, TWU	60
		TWU75	75
	Neutral-supported cable	NS-75	75
NS-90		90	
Nonmetallic-sheathed cable	NMWU	60	
For concealed wiring in dry locations only	Armored cable	TECK90	90
		AC90	90
For concealed wiring in dry and damp locations	Nonmetallic-sheathed cable	NMD90	90
For concealed wiring in dry locations and in Category 1 and 2 locations where not exposed to mechanical injury	Nonmetallic-sheathed cable	NMW, NMWU	60

Continued &gt;&gt;



Table 15.1—CSA Cable Types (Continued)

Conditions of Use	Trade Designation	CSA Type Designation	Maximum Allowable Conductor Temperature °C
For concealed wiring in wet locations	Armored cable	TECK90	90
		ACWU90	90
	Nonmetallic-sheathed cable	NMWU	60
	Aluminum-sheathed cable	RA75	75
		RA90	90
Mineral-insulated cable	MI, LWMI	90	
For use in raceways, except cable trays, in dry or damp locations	Rubber- (thermoset-) insulated cable	R90	90
	Thermoplastic-insulated cable	TW	60
	Nylon jacketed thermoplastic-insulated cable	T90 NYLON	90
For use in raceways, except cable trays, in wet locations	Rubber- (thermoset-) insulated cable	RW75, RWU75	75
		RW90, RWU90	90
	Thermoplastic-insulated cable	TW, TWU	60
		TW75, TWN75, TWU75	75
For use in ventilated, nonventilated and ladder type cable trays in dry locations only	Armored cable	AC90	90
		TECK90	90
For use in ventilated, nonventilated and ladder type cable trays in wet locations	Armored cable	TECK90	90
		ACWU90	90
	Aluminum-sheathed cable	RA75	75
		RA90	90
	Mineral-insulated cable	MI, LWMI	90
	Rubber- (thermoset-) insulated lead-sheathed cable	RL90	90
For use in ventilated and nonventilated cable trays in vaults and switch rooms	Rubber- (thermoset-) insulated cable	RW75	75
		RW90	90
For direct earth burial (with protection as required by inspection authority)	Armored cable	ACWU90	90
		TECK90	90
	Nonmetallic-sheathed cable	NMWU	60
	Rubber- (thermoset-) insulated cable	RWU75	75
		RL90, RWU90	90
	Aluminum-sheathed cable	RA75	75
		RA90	90
For direct earth burial (with protection as required by inspection authority)	Mineral-insulated cable	MI, LWMI	90
	Thermoplastic-insulated cable	TWU	60
		TWU75	75
	Airport series lighting cable	ASLC	90
	Tray cable	TC	90
For service entrance above ground	Armored cable	AC90	90
		ACWU90	90
		TECK90	90
	Aluminum-sheathed cable	RA75	75
		RA90	90
	Mineral-insulated cable	MI	90
	Neutral supported cable	NS-75	75
		NSF-90	90

Continued &gt;&gt;

Table 15.1—CSA Cable Types (Continued)

Conditions of Use	Trade Designation	CSA Type Designation	Maximum Allowable Conductor Temperature °C
For service entrance below ground	Service-entrance cable	USEI75	75
		USEI90	90
		USEB90	90
	Thermoplastic-insulated wire	TWU	60
		TWU75	75
	Rubber- (thermoset-) insulated cable	RWU75	75
		RWU90	90
	Armored cable	TECK90	90
ACWU90		90	
Aluminum-sheathed cable	RA75	75	
	RA90	90	
For high-voltage wiring in luminous-tube signs	Luminous-tube sign cable	GTO, GTOL	60
For use in raceways in hoistways	Hoistway cable	—	60
For use in Class 2 circuits, in exposed or concealed wiring or use in raceways, in dry or damp locations	Extra-low-voltage control cable	LVT	60
For use in Class 2 circuits in dry locations in concealed wiring or exposed wiring where not subject to mechanical injury	Extra-low-voltage control cable	ELC	60
For use when concealed indoors under carpet squares in dry or damp locations	Flat conductor cable	FCC	60
For use in communication circuits when exposed, concealed or used in raceways, indoors in dry or damp locations, or in ceiling air handling plenums	Communication cable	CMP, CMR, CMG, CM, CMX, CMH	60
For use in fire alarm, signal and voice communication circuits where exposed, concealed or used in raceways, indoors in dry or damp locations	Fire alarm and signal cable	FAS	60
		FAS 90	90
		FAS 105	105
		FAS 200	200
For use in raceways including ventilated, nonventilated and ladder type cable trays in wet locations and where exposed to weather	Tray cable	TC	As marked on cable
For use in cable trays in Class I Division 2 and Class II on cable Division 2 hazardous locations	Tray cable	TC	As marked on cable
For use in buildings in dry or damp locations, where exposed, concealed or used in raceways including cable trays, or in plenums	Non-conductive optical fiber cable	OFNP, OFNR, OFNG, OFN, OFNH	As marked on cable
For use in buildings in dry or damp locations, where exposed, concealed or used in raceways including cable trays, or in plenums	Conductive optical fiber cable	OFCP, OFCR, OFCG, OFC, OFCH	As marked on cable

Continued &gt;&gt;

Table 15.1—CSA Cable Types (Continued)

Conditions of Use	Trade Designation	CSA Type Designation	Maximum Allowable Conductor Temperature °C
For use in buildings in dry or damp locations, where exposed or concealed	Hybrid conductor cable	NMDH90	90
For use in ventilated non-ventilated and ladder type trays, direct earth burial, in ceiling air handling plenums, for exposed or concealed wiring (or damp or dry) locations	Control and instrumentation Cable (without armor)	CIC	250 (dry or damp locations) 90 (wet locations)
For use in ventilated non-ventilated and ladder type trays, direct earth burial, for exposed or concealed wiring in wet (or damp or dry) locations in ceiling air handling plenums	Armored control and instrumentation cable (other than steel wire armor)	ACIC	250 (dry or damp locations) 90 (wet locations)

Source: Canadian Electrical Code (CSA C22.1, Table 19)



### 15.3 SUPPLY VOLTAGE AND PLUG CONFIGURATIONS

Table 15.2—Canadian Supply Voltage

Frequency (Hz)	Voltage
60	120/240

The neutral wire of the secondary distribution system is grounded. Three-phase, 4-wire systems such as 120/208 volts are available as well as 347/600 volts for commercial establishments.

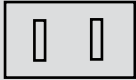
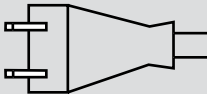
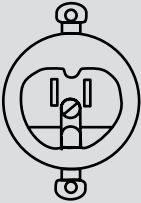
Table 15.3—Canadian Plug Configurations

Jack	Plug	Description
		North American Ungrounded
		North American NEMA 5-15

## 15.4 FIRE RATINGS

---

The Canadian Electrical Code, published by the Canadian Standards Association, is the national safety code for electrical installations that is adopted into law by each province and territory with amendments or local rules. The Code includes references to a stringent series of tests developed for flame testing of wires and cables. Cables are marked from “FT1” to “FT6,” depending on which of the specified flame test requirements they fulfill.

### 15.4.1 “FT1” Fire Test

The FT1 test procedure is known as the “Vertical Test” (published in CSA Standard C22.2 No. 0.3 Test Methods for Electrical Wires and Cables, para 4.11.1).

Cables are subjected to five, 15 second duration applications of a specified flame. For the cable to pass the test, burning must cease within 60 seconds after removal of the flame source, and not more than 25 percent of the extended portion of the indicator can be burned.

### 15.4.2 “FT4” Fire Test

The FT4 test procedure is known as the Vertical Flame Test – Cables in trays (published in CSA Standard C22.2 No. 0.3 Test Methods for Electrical Wires and Cables, para 4.11.4).

Cables are mounted on a vertical tray and exposed for 20 minutes to a 70,000 Btu/hr flame. For the cable to pass the test, the resulting char distance must not be greater than 1.5 meters from the point of flame application.

### 15.4.3 “FT6” Fire Test

The FT6 test procedure is known as the Plenum Flame Test (published in CSA Standard C22.2 No. 0.3 Test Methods for Electrical Wires and Cables, para 4.11.6).

### 15.4.4 Designations

The markings for wires and cables meeting the flame spread requirements of the National Building Code of Canada (without additional fire protection) are:

FT1 – Wires and cables that are suitable for installation in buildings of combustible construction; and

FT4 – Wires and cables that are suitable for installation in:

- (a) buildings of noncombustible and combustible construction; and
- (b) spaces between a ceiling and floor, or ceiling and roof, that may be used as a plenum in buildings of combustible or noncombustible construction.

Wires and cables with combustible outer jackets or sheaths that do not meet the above classifications should be located in noncombustible raceways, masonry walls or concrete slabs.

## 15.5 SINGLE CONDUCTOR TECK 90 TERMINATIONS

Single-conductor high-current armored cables require special termination methods to prevent excessive heating caused by induced “circulating currents” in nearby conductors and “eddy currents” in nearby magnetic materials. One acceptable method is shown in **Figure 15.1**.

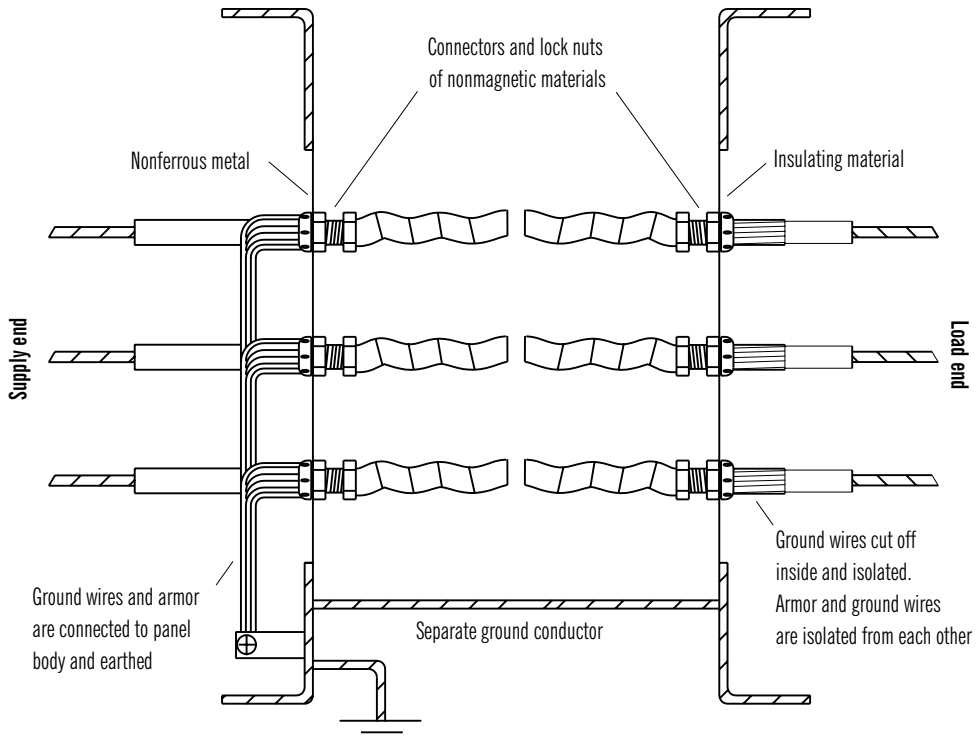

Figure 15.1—Termination of Single-Phase Single-Conductor Teck 90 Cables for Circuit Ampacity Over 425 Amps



# 16. ASIA PACIFIC

<b>16.1</b>	<b>Australian Standards</b>	<b>236</b>
16.1.1	SAA	236
16.1.2	ACMA	236
16.1.3	Supply Voltages and Plug Configuration	236
16.1.4	Limiting Temperatures for Insulated Cables	237
<b>16.2</b>	<b>Singapore Standards</b>	<b>238</b>
16.2.1	SPRING Singapore (formerly PSB)	238
16.2.2	Supply Voltage and Plug Configurations	238
<b>16.3</b>	<b>Japanese Standards</b>	<b>239</b>
16.3.1	JSA	239
16.3.2	Plug Configuration	239
<b>16.4</b>	<b>Chinese Standards</b>	<b>240</b>
16.4.1	CQC	240
16.4.2	CNIS	240

## 16.1 AUSTRALIAN STANDARDS

### 16.1.1 SAA

#### Standards Australia

[www.standards.org.au](http://www.standards.org.au) or [www.saiglobal.com](http://www.saiglobal.com)

Document No.	Title
AS/NZS 1026	Impregnated Paper Insulated Cables for Electricity Supply at Working Voltages Up To and Including 33 kV (Metric Units)
AS/NZS 1125	Conductors in Insulated Electric Cables and Flexible Cords
AS/NZS 1995	Welding Cables
AS/NZS 2380	Electrical Equipment for Explosive Atmospheres — Explosion Protection Techniques
AS/NZS 2381	Electrical Equipment for Explosive Atmospheres — Selection, Installation and Maintenance
AS/NZS 2430	Classification of Hazardous Areas
AS/NZS 3000	Australian/New Zealand Wiring Rules
AS/NZS 3008.1	Electrical Installations — Selection of Cables: Cables for Alternating Voltages Up To and Including 0.6/1 kV
AS/NZS 3112	Plugs and Socket-Outlets
AS/NZS 3123	Plugs, Socket-Outlets and Couplers for General Industrial Application
AS/NZS 3158	Fibrous-Insulated Electric Cables and Flexible Cables for Working Voltages of 0.6/1 kV
AS/NZS 3166	Cables for High-Voltage Luminous Discharge Tube Installations
AS/NZS 4961	Electric Cables — Polymeric Insulated — For Distribution and Service Applications
AS/NZS 3191	Electric Flexible Cords
AS/NZS 3560	Electric Cables — Aerial-Bundled Voltages Up To and Including 0.6/1 kV
AS/NZS 1972	Mining Cables Other Than Reeling and Trailing
AS/NZS 5000.1	Electric Cables — Polymeric Insulated — For Working Voltages Up To and Including 0.6/1 kV
AS/NZS 5000.2	Electric Cables — Polymeric Insulated — For working voltages Up To 450/750 V
AS/NZS 5000.3	Electric Cables — Polymeric Insulated — Multicore Control Cables
AS/NZS 60702	Mineral-Insulated Cables and Their Terminations Up To 750 V
AS/ACIF S008	Requirements for Authorized Cabling Products
AS/ACIF S009	Installation Requirements for Customer Cabling (Wiring Rules)

### 16.1.2 ACMA

#### Australian Communications and Media Authority

[www.acma.gov.au](http://www.acma.gov.au)

### 16.1.3 Supply Voltages and Plug Configuration

**Table 16.1—Australian Supply Voltages**

Frequency (Hz)	Voltage
50	240/415
50	250/440

The neutral wire of the secondary distribution system is grounded. A grounding conductor is required in the electrical cord attached to appliances that are not double insulated.



Table 16.2—Australian Plug Configuration

Jack	Plug	Description
		Australian Standard AS/NZS 3312

### 16.1.4 Limiting Temperatures for Insulated Cables

Table 16.3—Limiting Temperatures for Australian Insulated Cables

Type of Cable Insulation	Cable Operating Temperature, °C	
	Normal Use	Minimum
<b>Elastomer compounds</b>		
Type R-EP-90	90	-40
Type R-CSP-90	90	-20
Type R-CPE-90	90	-20
Type R-HF-90	90	-20
Type R-S-150	150	-50
Type R-S-200	200	-50
<b>Thermoplastic compounds</b>		
Type V-75	75	0
Type HFI-75-TP	75	-20
Type V-90	75	0
Type HFI-90-TP	75	-20
Type V-90-HT	75	0
<b>Heat-resisting fibrous insulation</b>		
Type 150	150	0
Type 200	200	0
Type 350	350	0
<b>Cross-linked polyethylene (XLPE)</b>		
Type X-90	90	-70
Type X-HF-90	90	-70

Source: Australian/New Zealand Wiring Rules (AS/NZS 3000)

## 16.2 SINGAPORE STANDARDS

### 16.2.1 SPRING Singapore (formerly PSB)

[www.spring.gov.sg](http://www.spring.gov.sg)

Document No.	Title
SS254	Electrical Apparatus for Explosive Gas Atmospheres
SS299 Part 1	Fire Resistant Circuit Integrity Power Cables
SS300	Methods of Test for Gases Evolved During Combustion of Electric Cables
SS358	PVC Insulated Power Cables up to and Including 450/750 V

The following British and international cable standards are also used in Singapore: BS6004, BS6346, BS6500, IEC 60331 and IEC 60502.



### 16.2.2 Supply Voltage and Plug Configurations

**Table 16.4—Singapore Supply Voltage**

Frequency (Hz)	Voltage
50	230/400

A grounding conductor is required in the electrical cord attached to appliances.

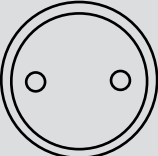
**Table 16.5—Singapore Plug Configurations**

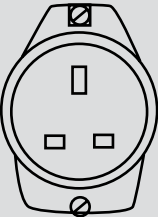
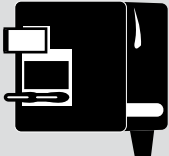
Jack	Plug	Description
		<b>Ungrounded Europlug</b> CEE 7/16
		<b>British Standard</b> BS 1363

## 16.3 JAPANESE STANDARDS

### 16.3.1 JSA

Japanese Standards Association

[www.jsa.or.jp](http://www.jsa.or.jp)

Document No.	Title
JIS C3307	600 V PVC Insulated Wires
JIS C3316	PVC Insulated Wire for Electrical Apparatus
JIS C3401	Control Cables
JIS C3406	Low Voltage Cables for Automobiles
JIS C3605	600 V Polyethylene Insulated Cables
JIS C3606	High-Voltage Cross Linked Polyethylene Insulated Cables
JIS C3609	High-Voltage Drop Wires for Pole Transformers
JIS C3612	600 V Flame Retardant Polyethylene Insulated Wires
JIS C3621	600 V Ethylene-Propylene Rubber Insulated Cables
JIS C3650	Installation Methods of Cables Embedded in Concrete
JIS C3653	Installation Methods of Cables Buried Underground
JIS C3660	Test Methods for Insulating and Sheathing Materials of Electric Cables
JIS C3662	PVC Insulated Cables Rated Up To 450/750 V
JIS C3663	Rubber Insulated Cables Rated Up To 450/750 V

### 16.3.2 Plug Configuration

Table 16.6—Japanese Plug Configuration

Jack	Plug	Description
		<p><b>Japanese Standard</b>            JIS C 8303 (Same as NEMA 5-15 and CSA 22.2, No. 42)</p>

## 16.4 CHINESE STANDARDS

---

### 16.4. CQC

Chinese Quality Certification Center

[www.cqc.com.cn](http://www.cqc.com.cn)

### 16.4.2 CNIS

Chinese National Institute of Standardization

[www.cnis.gov.cn](http://www.cnis.gov.cn)

Document No.	Title
GB 5013	Rubber Insulated Cables of Rated Voltages Up To and Including 450/750 V
GB 5023	Polyvinyl Chloride Insulated Cables for Rated Voltages Up To and Including 450/750 V
GB 12528.1	Insulated Cables (Wires) for Railway Vehicles of Rated Voltage Up To and Including 3 kV
GB 12972	Flexible Rubber-Sheathed Cables for Mining Purposes
GB 15934	Cord Sets

# 17. CONVERSION TABLES

17.1	Metric to English Conductor Size	242
17.2	Circular Measurements – Diameter, Circumference and Area	244
17.3	Length, Weight, Area, Power and Energy	246
17.4	Temperature Conversion	248
17.5	kVA to Amperes	249
17.6	Horsepower to Amperes	249

17.1 METRIC TO ENGLISH CONDUCTOR SIZE

Table 17.1—Conductor Size Conversion: Metric to English and English to Metric

Metric Conductor Area (mm <sup>2</sup> )	Standard Metric Sizes (mm <sup>2</sup> )	Standard English Sizes (kcmil/AWG)	English Conductor Area (cmil)	Metric Conductor Area (mm <sup>2</sup> )	Standard Metric Sizes (mm <sup>2</sup> )	Standard English Sizes (kcmil/AWG)	English Conductor Area (cmil)
1,015	—	2,000	2,000,000	120	120	—	237,000
1,000	1,000	—	1,970,000	119	—	—	234,000
900	—	—	1,780,000	107	—	4/0	211,600
888	—	1,750	1,750,000	100	—	—	197,000
800	800	—	1,580,000	95	95	—	187,000
761	—	1,500	1,500,000	85	—	3/0	167,800
635	—	1,250	1,250,000	72	—	—	141,800
630	630	—	1,240,000	70	70	—	138,000
626	—	—	1,233,000	67	—	2/0	133,100
520	—	—	1,024,000	60.9	—	—	119,900
508	—	1,000	1,000,000	54	—	1/0	105,600
500	500	—	987,000	51.6	—	—	101,600
449	—	—	884,000	50	50	—	98,500
400	400	—	789,000	43.7	—	—	86,100
381	—	750	750,000	42	—	1	83,700
380	—	—	748,000	37	—	—	72,900
322	—	—	634,000	35	35	—	69,100
305	—	600	600,000	34	—	2	66,360
300	300	—	592,000	31.3	—	—	61,660
273	—	—	537,000	27	—	3	52,620
254	—	500	500,000	25	25	—	49,300
240	240	—	474,000	22.4	—	—	44,128
231	—	—	455,000	21	—	4	41,740
230	—	400	400,000	19	—	—	37,430
195	—	—	384,000	17	—	5	33,090
185	185	—	365,000	16.1	—	—	31,717
178	—	350	350,000	16	16	—	31,600
165	—	—	325,000	13.6	—	—	26,792
152	—	300	300,000	13.3	—	6	26,240
150	150	—	296,000	11.5	—	—	22,655
140	—	—	276,000	10.5	—	7	20,820
127	—	250	250,000	10.00	10	—	19,700

Continued >>

Table 17.1—Conductor Size Conversion: Metric to English and English to Metric (Continued)

Metric Conductor Area	Standard Metric Sizes	Standard English Sizes	English Conductor Area	Metric Conductor Area	Standard Metric Sizes	Standard English Sizes	English Conductor Area
(mm <sup>2</sup> )	(mm <sup>2</sup> )	(kcmil/AWG)	(cmil)	(mm <sup>2</sup> )	(mm <sup>2</sup> )	(kcmil/AWG)	(cmil)
9.77	—	—	19,246	0.128	—	26	253
8.38	—	8	16,510	0.081	—	28	159
8.27	—	—	16,292	0.051	—	30	100
7.00	—	—	13,790	0.032	—	32	63.2
6.64	—	9	13,090	0.020	—	34	39.8
6.00	6	—	11,800	0.013	—	36	25.0
5.93	—	—	11,682	0.0080	—	38	15.7
5.26	—	10	10,380	0.0050	—	40	9.61
5.02	—	—	9,889	0.0032	—	42	6.25
4.25	—	—	8,372	0.0020	—	44	4.00
4.00	4	—	7,890	0.0013	—	46	2.56
3.60	—	—	7,092				
3.31	—	12	6,530				
2.58	—	—	5,082				
2.50	2.5	—	4,930				
2.18	—	—	4,294				
2.08	—	14	4,110				
1.85	—	—	3,644				
1.57	—	—	3,093				
1.50	1.5	—	2,960				
1.33	—	—	2,620				
1.31	—	16	2,580				
1.12	—	—	2,206				
1.00	1	—	1,970				
0.95	—	—	1,871				
0.82	—	18	1,620				
0.75	0.75	—	1,480				
0.68	—	—	1,339				
0.58	—	—	1,142				
0.52	—	20	1,020				
0.50	0.50	—	987				
0.49	—	—	965				
0.324	—	22	640				
0.205	0.2	24	404				

Reference: IEC 60228

**17.2 CIRCULAR MEASUREMENTS – DIAMETER, CIRCUMFERENCE AND AREA**

**Table 17.2—Circular Measurements – Diameter, Circumference and Area**

Diameter		Circumference		Diameter		Circumference	
Fractional (in.)	Decimal (in.)	(in.)	(sq. in.)	Fractional (in.)	Decimal (in.)	(in.)	(sq. in.)
1/64	0.015625	0.049087	0.00019	1	1.000000	3.14159	0.78540
1/32	0.031250	0.098175	0.00019	1 1/16	1.062500	3.33794	0.88664
3/64	0.046875	0.147262	0.00173	1 1/8	1.125000	3.53429	0.99402
1/16	0.062500	0.196350	0.00307	1 3/16	1.187500	3.73064	1.1075
3/32	0.093750	0.294524	0.00690	1 1/4	1.250000	3.92699	1.2272
1/8	0.125000	0.392699	0.01227	1 5/16	1.312500	4.12334	1.3530
5/32	0.156250	0.490874	0.01917	1 3/8	1.375000	4.31969	1.4849
3/16	0.187500	0.589049	0.02761	1 7/16	1.437500	4.51604	1.6230
7/32	0.218750	0.687223	0.03758	1 1/2	1.500000	4.71239	1.7671
1/4	0.250000	0.785398	0.04909	1 9/16	1.562500	4.90874	1.9175
9/32	0.281250	0.883573	0.06213	1 5/8	1.625000	5.10509	2.0739
5/16	0.312500	0.981748	0.07670	1 11/16	1.687500	5.30144	2.2365
11/32	0.343750	1.07992	0.09281	1 3/4	1.750000	5.49779	2.4053
3/8	0.375000	1.17810	0.11045	1 13/16	1.812500	5.69414	2.5802
13/32	0.406250	1.27627	0.12962	1 7/8	1.875000	5.89049	2.7612
7/16	0.437500	1.37445	0.15033	1 15/16	1.937500	6.08684	2.9483
15/32	0.468750	1.47262	0.17257	2	2.000000	6.28319	3.1416
1/2	0.500000	1.57080	0.19635	2 1/16	2.062500	6.47953	3.3410
17/32	0.531250	1.66897	0.22166	2 1/8	2.125000	6.67588	3.5466
9/16	0.562500	1.76715	0.24850	2 3/16	2.187500	6.87223	3.7583
19/32	0.593750	1.86532	0.27688	2 1/4	2.250000	7.06858	3.9761
5/8	0.625000	1.96350	0.30680	2 5/16	2.312500	7.26493	4.2000
21/32	0.656250	2.06167	0.33824	2 3/8	2.375000	7.46128	4.4301
11/16	0.687500	2.15984	0.37122	2 7/16	2.437500	7.65763	4.6664
23/32	0.718750	2.25802	0.40574	2 1/2	2.500000	7.85398	4.9087
3/4	0.750000	2.35619	0.44179	2 9/16	2.562500	8.05033	5.1572
25/32	0.781250	2.45437	0.47937	2 5/8	2.625000	8.24668	5.4119
13/16	0.812500	2.55254	0.51849	2 11/16	2.687500	8.44303	5.6727
27/32	0.843750	2.65072	0.55914	2 3/4	2.750000	8.63938	5.9396
7/8	0.875000	2.74889	0.60132	2 13/16	2.812500	8.83573	6.2126
29/32	0.906250	2.84707	0.64504	2 7/8	2.875000	9.03208	6.4978
15/16	0.937500	2.94524	0.69029	2 15/16	2.937500	9.22843	6.7771
31/32	0.968750	3.04342	0.73708	3	3.000000	9.42478	7.0686

Continued >>



Table 17.2—Circular Measurements — Diameter, Circumference and Area (Continued)

Diameter		Circumference		Diameter		Circumference	
Fractional (in.)	Decimal (in.)	(in.)	(sq. in.)	Fractional (in.)	Decimal (in.)	(in.)	(sq. in.)
3 1/16	3.062500	9.62113	7.3662	5 1/4	5.250000	16.4943	21.648
3 1/8	3.125000	9.81748	7.6699	5 5/16	5.312500	16.6897	22.166
3 3/16	3.187500	10.01380	7.9798	5 3/8	5.375000	16.8861	22.691
3 1/4	3.250000	10.2102	8.2958	5 7/16	5.437500	17.0824	23.221
3 5/16	3.312500	10.4065	8.6179	5 1/2	5.500000	17.2788	23.758
3 3/8	3.375000	10.6029	8.9462	5 9/16	5.562500	17.4751	24.301
3 7/16	3.437500	10.7992	9.2806	5 5/8	5.625000	17.6715	24.850
3 1/2	3.500000	10.9956	9.6211	5 11/16	5.687500	17.8678	25.406
3 9/16	3.562500	11.1919	9.9678	5 3/4	5.750000	18.0642	25.967
3 5/8	3.625000	11.3883	10.3206	5 13/16	5.812500	18.2605	26.535
3 11/16	3.687500	11.5846	10.6796	5 7/8	5.875000	18.4589	27.109
3 3/4	3.750000	11.7810	11.0447	5 15/16	5.937500	18.6532	27.688
3 13/16	3.812500	11.9773	11.4159	6	6.000000	18.8496	28.274
3 7/8	3.875000	12.1737	11.7932	6 1/8	6.125000	19.2423	29.465
3 15/16	3.937500	12.3700	12.1767	6 1/4	6.250000	19.6350	30.680
4	4.000000	12.5664	12.566	6 3/8	6.375000	20.0277	31.919
4 1/16	4.062500	12.7627	12.962	6 1/2	6.500000	20.4202	33.183
4 1/8	4.125000	12.9591	13.364	6 5/8	6.625000	20.8131	34.472
4 3/16	4.187500	13.1554	13.772	6 3/4	6.750000	21.2058	35.785
4 1/4	4.250000	13.3518	14.186	6 7/8	6.875000	21.5984	37.122
4 5/16	4.312500	13.5481	14.607	7	7.000000	21.9911	38.485
4 3/8	4.375000	13.7445	15.033	7 1/8	7.125000	22.3838	39.871
4 7/16	4.437500	13.9408	15.466	7 1/4	7.250000	22.7765	41.282
4 1/2	4.500000	14.1372	15.904	7 3/8	7.375000	23.1692	42.718
4 9/16	4.562500	14.3335	16.349	7 1/2	7.500000	23.5619	44.179
4 5/8	4.625000	14.5299	16.800	7 5/8	7.625000	23.9546	45.664
4 11/16	4.687500	14.7262	17.257	7 3/4	7.750000	24.3473	47.173
4 3/4	4.750000	14.9226	17.721	7 7/8	7.875000	24.7400	48.707
4 13/16	4.812500	15.1189	18.190	8	8.000000	25.1327	50.265
4 7/8	4.875000	15.3153	18.665	8 1/8	8.125000	25.5254	51.849
4 15/16	4.937500	15.5116	19.147	8 1/4	8.250000	25.9181	53.456
5	5.000000	15.7050	19.635	8 3/8	8.375000	26.3108	55.088
5 1/16	5.062500	15.9043	20.129	8 1/2	8.500000	26.7035	56.745
5 1/8	5.125000	16.1007	20.629	8 5/8	8.625000	27.0962	58.426
5 3/16	5.187500	16.2970	21.135	8 3/4	8.750000	27.4889	60.132

Continued &gt;&gt;

## 17. Conversion Tables

**Table 17.2—Circular Measurements – Diameter, Circumference and Area (Continued)**

Diameter		Circumference		Diameter		Circumference	
Fractional (in.)	Decimal (in.)	(in.)	(sq. in.)	Fractional (in.)	Decimal (in.)	(in.)	(sq. in.)
8 7/8	8.875000	27.8816	61.862	9 1/2	9.500000	29.8451	70.882
9	9.000000	28.2743	63.617	9 5/8	9.625000	30.2378	72.760
9 1/8	9.125000	28.6670	65.397	9 3/4	9.750000	30.6305	74.662
9 1/4	9.250000	29.0597	67.201	9 7/8	9.875000	31.0232	76.589
9 3/8	9.375000	29.4524	69.029	10	10.000000	31.4159	78.540

- Notes: 1. Multiply square inches by 645.16 to calculate mm<sup>2</sup>.  
 2. Multiply inches by 25.4 to calculate mm.  
 3. Multiply inches by 1,000 to calculate mils.

## 17.3 LENGTH, WEIGHT, AREA, POWER AND ENERGY

**Table 17.3—Conversion Factors**

Note: Frequently used conversions are shown in **bold type**. To convert in the reverse direction, divide by the factor given in the table.

To Convert From	To	Multiply By	To Convert From	To	Multiply By
<b>Area</b>			<b>Length</b>		
Circular mils	Square inches	0.000007854	Centimeters	Inches	0.3937
Circular mils	Square mils	0.7854	Centimeters	Feet	0.03281
<b>Circular mils</b>	<b>Square millimeters</b>	<b>0.0005067</b>	Feet	Centimeters	30.48
Square centimeters	Square inches	0.155	<b>Feet</b>	<b>Meters</b>	<b>0.3048</b>
Square feet	Square meters	0.0929	Inches	Centimeters	2.54
Square inches	Circular mils	1,273,240.00	Inches	Meters	0.0254
Square inches	Square centimeters	6.4516	<b>Inches</b>	<b>Millimeters</b>	<b>25.4</b>
Square inches	Square millimeters	645.16	Inches	Mils	1,000.00
Square inches	Square mils	1,000,000.00	Kilometers	Miles	0.6214
Square meters	Square feet	10.764	<b>Meters</b>	<b>Feet</b>	<b>3.2808</b>
Square millimeters	Square inches	0.00155	Meters	Inches	39.3701
<b>Square millimeters</b>	<b>Circular mils</b>	<b>1,973.53</b>	Meters	Yards	1.0936
Square mils	Circular mils	1.2732	Miles	Kilometers	1.6093
Square mils	Square inches	0.000001	<b>Millimeters</b>	<b>Inches</b>	<b>0.03937</b>
			Millimeters	Mils	39.3701
			Mils	Inches	0.001
			Mils	Millimeters	0.0254
			Yards	Meters	0.9144

Continued >>

Table 17.3—Conversion Factors (Continued)

To Convert From	To	Multiply By	To Convert From	To	Multiply By
<b>Power</b>			<b>Energy</b>		
Foot-pounds per minute	Horsepower	0.000303	British thermal units	Foot-pounds	778.00
Foot-pounds per minute	Watts	0.0226	British thermal units	Joules	1,055.00
Foot-pounds per second	Horsepower	0.001818	British thermal units	Watt-hours	0.293
Foot-pounds per second	Watts	1.356	Foot-pounds	British thermal units	0.001285
Horsepower	Foot-pounds per minute	33,000.00	Foot-pounds	Joules	1.356
Horsepower	Foot-pounds per second	550.00	Foot-pounds	Kilogram-meters	0.1383
<b>Horsepower</b>	<b>Watts</b>	<b>746</b>	Gram calories	Joules	4.186
Kilogram-meters per sec.	Watts	9.807	Joules	British thermal units	0.000947
Watts	Foot-pounds per minute	44.25	Joules	Ergs	107.00
Watts	Foot-pounds per second	0.7375	Joules	Foot-pounds	0.7375
Watts	Horsepower	0.001341	Joules	Gram-calories	0.2388
Watts	Kilogram-meters per sec.	0.1020	Joules	Kilogram-meters	0.10198
			Kilogram-meters	Foot-pounds	7.233
			Kilogram-meters	Joules	9.8117
			Watt-hours	British thermal units	3.4126

To Convert From	To	Multiply By	To Convert From	To	Multiply By
<b>Weight</b>			<b>Miscellaneous</b>		
Kilograms	Pounds	2.205	Diameter circle	Circumference	3.1416
<b>Kilograms per kilometer</b>	<b>Pounds per 1,000 feet</b>	<b>0.6719</b>	Diameter circle	Side of equal square	0.8862
Ohms per kilometer	Ohms per 1,000 feet	0.3048	Diameter sphere cubed	Volume of sphere	0.5236
Ohms per 1,000 feet	Ohms per kilometer	3.2808	U.S. gallons	Imperial gallons (British)	0.8327
Ohms per 1,000 yards	Ohms per kilometer	1.0936	U.S. gallons	Cubic feet	0.1337
Pounds	Kilograms	0.4536	U.S. gallons	Pounds of water (20°C)	8.33
<b>Pounds per 1,000 feet</b>	<b>Kilograms per kilometer</b>	<b>1.488</b>	Cubic feet	Pounds of water (4°C)	62.427
Pounds per 1,000 yards	Kilograms per kilometer	0.4960	Feet of water (4°C)	Pounds per square inch	0.4336
Pounds per 1,000 yards	Pounds per kilometer	1.0936	Inches of mercury (0°C)	Pounds per square inch	0.4912
Newtons	Pound-force	0.2248	Knots	Miles per hour	1.1516
Pound-force	Newtons	4.4482			

17.4 TEMPERATURE CONVERSION

Table 17.4—Degrees Celsius (Centigrade) vs. Degrees Fahrenheit

Conversion Formula: °F = 9/5°C + 32°C  
 °C = 5/9 (°F - 32)

°C	°F	°C	°F	°C	°F	°C	°F	°C	°F	°C	°F	°C	°F	°C	°F
-80	-112.0	-15	5.0	15	59.0	45	113.0	75	167.0	105	221.0	135	275.0	600	1,112
-70	-94.0	-14	6.8	16	60.8	46	114.8	76	168.8	106	222.8	136	276.8	700	1,292
-60	-76.0	-13	8.6	17	62.6	47	116.6	77	170.6	107	224.6	137	278.6	800	1,472
-50	-58.0	-12	10.4	18	64.4	48	118.4	78	172.4	108	226.4	138	280.4	900	1,652
-45	-49.0	-11	12.2	19	66.2	49	120.2	79	174.2	109	228.2	139	282.2	1,000	1,832
-40	-40.0	-10	14.0	20	68.0	50	122.0	80	176.0	110	230.0	140	284.0	1,000	2,012
-39	-38.2	-9	15.8	21	69.8	51	123.8	81	177.8	111	231.8	141	285.8	1,200	2,192
-38	-36.4	-8	17.6	22	71.6	52	125.6	82	179.6	112	233.6	142	287.6	1,300	2,372
-37	-34.6	-7	19.4	23	73.4	53	127.4	83	181.4	113	235.4	143	289.4	1,400	2,552
-36	-32.8	-6	21.2	24	75.2	54	129.2	84	183.2	114	237.2	144	291.2	1,500	2,732
-35	-31.0	-5	23.0	25	77.0	55	131.0	85	185.0	115	239.0	145	293.0	1,600	2,912
-34	-29.2	-4	24.8	26	78.8	56	132.8	86	186.8	116	240.8	146	294.8	1,700	3,092
-33	-27.4	-3	26.6	27	80.6	57	134.6	87	188.6	117	242.6	147	296.6	1,800	3,272
-32	-25.6	-2	28.4	28	82.4	58	136.4	88	190.4	118	244.4	148	298.4	1,900	3,452
-31	-23.8	-1	30.2	29	84.2	59	138.2	89	192.2	119	246.2	149	300.2	2,000	3,632
-30	-22.0	*0	*32.0	30	86.0	60	140.0	90	194.0	120	248.0	150	302.0	—	—
-29	-20.2	1	33.8	31	87.8	61	141.8	91	195.8	121	249.8	160	320.0	—	—
-28	-18.4	2	35.6	32	89.6	62	143.6	92	197.6	122	251.6	170	338.0	—	—
-27	-16.6	3	37.4	33	91.4	63	145.4	93	199.4	123	253.4	180	356.0	—	—
-26	-14.8	4	39.2	34	93.2	64	147.2	94	201.2	124	255.2	190	374.0	—	—
-25	-13.0	5	41.0	35	95.0	65	149.0	95	203.0	125	257.0	200	392	—	—
-24	-11.2	6	42.8	36	96.8	66	150.8	96	204.8	126	258.8	210	410	—	—
-23	-9.4	7	44.6	37	98.6	67	152.6	97	206.6	127	260.6	220	428	—	—
-22	-7.6	8	46.4	38	100.4	68	154.4	98	208.4	128	262.4	230	446		
-21	-5.8	9	48.2	39	102.2	69	156.2	99	210.2	129	264.2	240	464	—	—
-20	-4.0	10	50.0	40	104.0	70	158.0	†100	†212.0	130	266.0	250	482	—	—
-19	-2.2	11	51.8	41	105.8	71	159.8	101	213.8	131	267.8	300	572	—	—
-18	-0.4	12	53.6	42	107.6	72	161.6	102	215.6	132	269.6	350	662	—	—
-17	1.4	13	55.4	43	109.4	73	163.4	103	217.4	133	271.4	400	752	—	—
-16	3.2	14	57.2	44	111.2	74	165.2	104	219.2	134	273.2	500	932	—	—

\*Freezing †Boiling

## 17.5 KVA TO AMPERES

Table 17.5—kVA to Amperes

Single-Phase Circuits			
kVA Rating	Current in Amperes at:		
	120 V	240 V	480 V
1	8.33	4.16	2.08
1.5	12.5	6.24	3.12
2	16.66	8.33	4.16
3	25	12.5	6.1
5	41	21	10.4
7.5	62	31	15.6
10	83	42	21
15	124	62	31
25	208	104	52
37.5	312	156	78
50	416	208	104
75	624	312	156
100	830	415	207
167	1,390	695	348
200	1,660	833	416

Three-Phase Circuits				
kVA Rating	Current in Amperes at:			
	120 V	240 V	480 V	600 V
3	8.3	7.2	3.6	2.9
6	16.6	14.4	7.2	5.8
9	25.0	21.6	10.8	8.7
15	41.6	36	18	14.4
30	83.0	72	36	28.8
45	125	108	54	43
75	208	180	90	72
112.5	312	270	135	108
150	415	360	180	144
200	554	480	240	192
225	625	540	270	216
300	830	720	360	288
400	1,110	960	480	384
500	1,380	1,200	600	480
750	2,080	1,800	900	720

---

## 17.6 HORSEPOWER TO AMPERES

---

**Table 17.6—Horsepower to Amperes**

Three-Phase Circuits			
Horsepower Rating	Current in Amperes at:		
	208 V	240 V	480 V
1	2.9	2.5	1.2
2	5.8	5.0	2.5
5	14.4	12.5	6.2
10	28.8	25.0	12.5
20	57.6	49.9	25.0
50	144	125	62.4
100	288	250	125
200	576	500	250
300	—	—	624

Note: Based on a motor efficiency of 90 percent and system power factor of 0.8. Above values are theoretical values based solely on numerical calculations. Check with applicable codes for specific ampere values to size overcurrent protective devices or conductors. For example, see Table 430.250 of the National Electrical Code.

# 18. FORMULAS AND CONSTANTS

18.1	Electrical Properties of Circuits	252
18.2	Resistance and Weight of Conductors	252
18.3	Resistance, Inductance and Capacitance in AC Circuits	253
18.4	Series and Parallel Connections	253
18.5	Engineering Notation	254
18.6	Diameter of Multiconductor Cables	255
18.7	Determination of Largest Possible Conductor in Cable Interstices	255
18.8	Conductor Diameter from Wire Diameter	256
18.9	Coaxial Capacitance	256
18.10	Inductive Reactance	257

## 18.1 ELECTRICAL PROPERTIES OF CIRCUITS

Table 18.1—Electrical Properties of Circuits

Desired Data	Alternating Current		Direct Current
	Single Phase	Three Phase	
Kilowatts (kw)	$\frac{I \times V \times \cos \theta}{1,000}$	$\frac{1.73 \times I \times V \times \cos \theta}{1,000}$	$\frac{I \times V}{1,000}$
Kilovolt–amperes (kVA)	$\frac{I \times V}{1,000}$	$\frac{1.73 \times I \times V}{1,000}$	$\frac{I \times V}{1,000}$
Horsepower output	$\frac{I \times V \times \cos \theta \times \text{Eff.}}{746}$	$\frac{1.73 \times I \times V \times \cos \theta \times \text{Eff.}}{746}$	$\frac{I \times V \times \text{Eff.}}{746}$
Amperes (I) when horsepower is known	$\frac{\text{hp} \times 746}{V \times \cos \theta \times \text{Eff.}}$	$\frac{\text{hp} \times 746}{1.73 \times V \times \cos \theta \times \text{Eff.}}$	$\frac{\text{hp} \times 746}{V \times \text{Eff.}}$
Amperes (I) when kilowatts are known	$\frac{\text{kw} \times 1,000}{V \times \cos \theta}$	$\frac{\text{kw} \times 1,000}{1.73 \times V \times \cos \theta}$	$\frac{\text{kw} \times 1,000}{V}$
Amperes (I) when kilovolt-amperes are known	$\frac{\text{kVA} \times 1,000}{V}$	$\frac{\text{kVA} \times 1,000}{1.73 \times V}$	$\frac{\text{kVA} \times 1,000}{V}$

$\cos \theta$  = Power factor of load (pf)

V = Volts between conductors

Eff. = Efficiency of motor

I = Current (amperes)

kw = Kilowatts

kVA = Kilovolt–amperes

hp = Horsepower

## 18.2 RESISTANCE AND WEIGHT OF CONDUCTORS

The resistance and weight of any uncoated copper wire at 20°C (68°F) having a conductivity of 100 percent IACS may be calculated from the following formulas:

$$\text{ohms per 1,000 feet} = \frac{0.0081455}{\text{Cross-sectional area in sq. in.}} \quad \text{or} \quad \frac{10371.176}{\text{Cross-sectional area in cmils}}$$

$$\text{pounds per 1,000 feet} = \text{Area in sq. in.} \times 3,854.09 \text{ or area in cmils} \times 0.0030269$$



## 18.3 RESISTANCE, INDUCTANCE AND CAPACITANCE IN AC CIRCUITS

Table 18.2—Resistance, Inductance and Capacitance in AC Circuits

If Circuit Contains	Reactance	Impedance	“V” for Current “I”	Power Factor
Resistance (R) Only	0	R	IR	1
Inductance (L) Only	$2\pi fL$	$2\pi fL$	$I2\pi fL$	0
Capacitance (C) Only	$\frac{1}{2\pi fC}$	$\frac{1}{2\pi fC}$	$I \frac{1}{2\pi fC}$	0
Resistance and Inductance in Series (R and L)	$2\pi fL$	$\sqrt{R^2 + (2\pi fL)^2}$	$I \sqrt{R^2 + (2\pi fL)^2}$	$\frac{R}{\sqrt{R^2 + (2\pi fL)^2}}$
Resistance and Capacitance in Series (R and C)	$\frac{1}{2\pi fC}$	$\sqrt{R^2 + \left(\frac{1}{2\pi fL}\right)^2}$	$I \sqrt{R^2 + \left(\frac{1}{2\pi fL}\right)^2}$	$\frac{R}{\sqrt{R^2 + \left(\frac{1}{2\pi fL}\right)^2}}$
Resistance, Inductance and Capacitance in Series (R, L and C)	$2\pi fL - \frac{1}{2\pi fC}$	$\left(2\pi fL - \frac{1}{2\pi fC}\right)^2$	$\sqrt{R^2 + \left(2\pi fL - \frac{1}{2\pi fC}\right)^2}$	$\frac{R}{\sqrt{R^2 + \left(2\pi fL - \frac{1}{2\pi fC}\right)^2}}$

V = Voltage in volts    I = Current in amperes    L = Inductance in henries    f = Frequency in cycles per second  
 R = Resistance in ohms    C = Capacitance in farads     $\pi = 3.1416$

## 18.4 SERIES AND PARALLEL CONNECTIONS

Table 18.3—Series and Parallel Connections

	Resistance (R)	Inductance (L)	Capacitance (C)
Series	$R = R_1 + R_2 + R_3 + \dots$	$L = L_1 + L_2 + L_3 + \dots$	$\frac{1}{C} = \frac{1}{C_1} + \frac{1}{C_2} + \frac{1}{C_3} + \dots$
Parallel	$\frac{1}{R} = \frac{1}{R_1} + \frac{1}{R_2} + \frac{1}{R_3} + \dots$	$\frac{1}{L} = \frac{1}{L_1} + \frac{1}{L_2} + \frac{1}{L_3} + \dots$	$C = C_1 + C_2 + C_3 + \dots$

## 18.5 ENGINEERING NOTATION

Table 18.4—Engineering Notation

Prefix	Symbol	Multiplying Factor	
		Scientific	Conventional
tera	T	$10^{12}$	1,000,000,000,000
giga	G	$10^9$	1,000,000,000
mega	M	$10^6$	1,000,000
kilo	k	$10^3$	1,000
hecto	h	$10^2$	100
deca	da	$10^1$	10
deci	d	$10^{-1}$	0.1
centi	c	$10^{-2}$	0.01
milli	m	$10^{-3}$	0.001
micro	$\mu$	$10^{-6}$	0.000001
nano	n	$10^{-9}$	0.000000001
pico	p	$10^{-12}$	0.000000000001
femto	f	$10^{-15}$	0.000000000000001
atto	a	$10^{-18}$	0.000000000000000001

Table 18.5—Engineering Notation

Engineering Notation
$\epsilon = 2.7183$
$\pi = 3.1416$
$\sqrt{2} = 1.4142$
$\sqrt{3} = 1.7321$
$p/4 = 0.7854$
1/C = one conductor
3/C = three conductor
> greater than
$\leq$ less than or equal to
< less than
$\geq$ greater than or equal to

## 18.6 DIAMETER OF MULTICONDUCTOR CABLES

To calculate the overall diameter of a group of round conductors of uniform diameters twisted together, multiply the diameter of an individual conductor by the applicable factor below.

**Table 18.6—Diameter of Multiconductor Cables**

Number of Conductors	Factor
1	1.000
2	2.000
3	2.155
4	2.414
5	2.700
6	3.000
7	3.000
8	3.310
9	3.610

## 18.7 DETERMINATION OF LARGEST POSSIBLE CONDUCTOR IN CABLE INTERSTICES

The following factors permit the calculation of the maximum size conductor that will fit into the interstices (open spaces) of various conductor configurations, while keeping within a circumscribing circle. Multiply the diameter of one main conductor by the factor from the chart below to obtain the largest diameter that will fit into the interstices.

**Table 18.7—Determination of Largest Possible Conductor in Cable Interstices**

Number of Conductors	Factor
2	0.667
3	0.483
4	0.414
5	0.377
6	0.354

## 18.8 CONDUCTOR DIAMETER FROM WIRE DIAMETER

To calculate the nominal diameter of any concentric-lay-stranded conductor made from round wires of uniform diameters, multiply the diameter of an individual wire by the applicable factor below:

**Table 18.8—Concentric Stranded Conductor Diameter from Wire Diameter**

Number of Wires in Conductor	Factor to Calculate Conductor Diameter
3	2.155
7	3.000
12	4.155
19	5.000
37	7.000
61	9.000
91	11.00
127	13.00
169	15.00
217	17.00
271	19.00

For a greater number of wires use the formula: Conductor Diameter = Wire Diameter  $\times \sqrt{1.332 \times \text{No. of Wires}}$

## 18.9 COAXIAL CAPACITANCE

$$C = \frac{7.354e}{\text{Log}_{10}(1 + 2t/d)}$$

Where:

- C is capacitance in picofarads per foot
- e is the dielectric constant (also known as SIC)
- t is insulation thickness in mils
- d is diameter over the conductor (diameter under the insulation) in mils

Other forms of this equation include:

$$C_1 = \frac{0.0169e}{\text{Ln}\left(\frac{D}{d}\right)} \quad \text{or} \quad C_2 = \frac{0.0556e}{\text{Ln}\left(\frac{D}{d}\right)}$$

Where:

- $C_1$  is capacitance in microfarads per 1,000 ft.
- $C_2$  is capacitance in microfarads per kilometer
- e is the dielectric constant
- D is diameter over the insulation
- d is diameter under the insulation

---

## 18.10 INDUCTIVE REACTANCE

---

The inductive reactance of a shielded three-conductor medium-voltage power cable at 60 Hz can be calculated with the following formulas:

$$X_L = 0.023 \ln \left( \frac{\text{GMD}}{\text{GMR}} \right) \text{ ohms/1,000 ft.}$$

or

$$X_L = 0.0754 \ln \left( \frac{\text{GMD}}{\text{GMR}} \right) \text{ ohms/km}$$

Where:

GMD = geometric mean distance (equivalent conductor spacing)

GMR = geometric mean radius of conductor

For conductors in a triplexed configuration, GMD is equal to the center-to-center spacing. For round, concentric stranded conductors, GMR ranges from 0.363d for a 7-wire strand up to 0.386d for a 61-wire strand where “d” is the diameter of the conductor.



# GLOSSARY

## #

**0–10 V**—A common analog process control signal voltage range.

**4–20 mA**—A common analog process control signal current range.

## A

**A**—Common abbreviation for ampere (see AMPERE).

**AAAC**—All-aluminum alloy conductor. A special high-strength aluminum alloy.

**AAR**—American Association of Railroads.

**ABRASION RESISTANCE**—Ability of a material to resist surface wear.

**ABSORPTION**—Physical phenomenon that attenuates light traveling in fibers by converting it into heat, thereby raising the fiber's temperature. Absorption results from impurities and defects in the glass structure.

**AB SWITCH**—A coaxial cable switch capable of switching one cable to one of two branch cables, A or B.

**AC**—(1) Alternating current. (2) A UL cable type (armored cable) with flexible metal tape armor.

**ACAR**—Aluminum conductor, aluminum-reinforced cable. Used in overhead transmission and distribution.

**ACCELERATED LIFE TEST**—A test in which a cable is subjected to extreme conditions to determine the life of a cable.

**ACCR**—Aluminum conductor, composite reinforced aerial cable. Contains a ceramic strength member to reduce sag at high temperatures (up to 210°C).

**ACRF**—Attenuation to crosstalk ratio far-end. Communications cable specification. See ELFEXT.

**ACSR**—Aluminum conductor, steel reinforced. A bare composite of aluminum and steel wires, usually aluminum around steel.

**ACSR/AW**—Aluminum conductor, steel reinforced using aluminum clad steel wire.

**ACSR/AZ**—Aluminum conductor, steel reinforced using aluminum coated steel wire.

**ACSR/GA**—Aluminum conductor, steel reinforced using Class A zinc-coated steel wire.

**ACSR/GB**—Aluminum conductor, steel reinforced using Class B zinc-coated steel wire.

**ACSR/GC**—Aluminum conductor, steel reinforced, using Class C zinc-coated steel wire.

**ACSS**—Aluminum conductor steel supported. This transmission line has fully annealed aluminum for better sag and high-temperature performance than ACSR.

**A/D CONVERTER—ANALOG/DIGITAL**—An circuit device that converts analog signals to digital signals.

**ADDRESS**—The digital location of a terminal, a peripheral device, a node, or any other unit or component in a network, or process control system.

**ADHESIVE-BONDED**—Cables bonded by adding an adhesive coating to the surface of the cable components, then joining and curing the adhesive to form a cable. See BONDED CABLE.

**ADMITTANCE**—A measure of how easily alternating current flows in a circuit. Admittance is the reciprocal of impedance. It is expressed in mhos.

**AEIC**—Association of Edison Illuminating Companies. Electric energy industry association.

**AERIAL CABLE**—A cable suspended in the air on poles or other overhead structure.

**AF**—Audio frequency.

**AFCI**—Arc fault circuit interrupter. A protective device that detects arcing and breaks the circuit to protect the load when arcing is detected.

**AGC**—Automatic gain control. A feedback circuit that automatically adjusts the system gain.

**AGING**—The irreversible change of material properties after exposure to an environment for an interval of time.

**AIA**—Aluminum interlocked armor. A type of cable sheath consisting of interlocked pieces of aluminum armor.

**AIR CORE CABLE**—A cable in which the interstices in the cable core are not filled with a moisture barrier.

**AIRCRAFT WIRE**—An electrical wire primarily designed for the extreme conditions (temperature, altitude, solvents, fuels, etc.) of airborne equipment.

**AIR SPACED COAX**—A coaxial cable in which air is basically the dielectric material. The conductor may be centered by means of a spirally wound synthetic filament, beads or braided filaments. This construction is also referred to as an air dielectric.

**AL**—Aluminum

**ALLOY**—A substance (usually metallic) composed of two or more individual substances.

**ALS**—Aluminum sheathed. A type of cable consisting of insulated conductors enclosed in a continuous, closely fitting aluminum tube. Listed type in the Canadian Electric Code.

**ALTERNATING CURRENT**—Electric current that periodically reverses direction. Alternating current is generally abbreviated AC.

**AM**—Amplitude modulation. A method of adding information to an electronic signal where the amplitude of the wave is changed to convey the added information.

**AMBIENT**—Conditions existing at a location prior to energizing of equipment (example: ambient temperature).

**AMPACITY**—The rms current that a device can safely carry within specified temperature limitations in a specified environment: dependent upon a) temperature rating; b) power loss; c) heat dissipation; and d) applicable codes.



**AMPERE**—A standard unit of current. Designated as the amount of current that flows when one volt of EMF (electromotive force) is applied across one ohm of resistance. An ampere of current is flowing when one coulomb of charge is passing a point every second.

**AMPERE-TURN**—The product of amperes times the number of turns in a coil.

**AMPLIFIER**—A device used to boost the strength of an electronic signal.

**AMPLITUDE**—The peak value of a electrical signal.

**AMPLITUDE MODULATION (AM)**—A method of adding information to an electronic signal where the amplitude of the wave is changed to convey the added information.

**ANALOG**—A continuously varying waveform that has not been digitized.

**ANNEAL**—To soften and relieve strains in any solid material, such as metal or glass, by heating to just below its melting point and then slowly cooling it. This also generally lowers the tensile strength of the material, while improving its flex life.

**ANNEALED WIRE**—See **SOFT WIRE**.

**ANNULAR CONDUCTOR**—A number of wires stranded in reversed concentric layers around a core.

**ANNUNCIATOR WIRE**—Usually single solid copper, sometimes twisted pair or triplexed for open wiring of bell circuits and other low-voltage systems.

**ANSI (American National Standards Institute)**—A not-for-profit organization that publishes nationally recognized standards.

**ANTENNA LEAD-IN WIRE**—Not coaxial; parallel twin lead construction, plastic jacketed with fixed 300-ohm impedance for connecting a remote antenna to a receiver.

**ANTENNA ROTOR CABLE**—Multiconductor flat or round cable used to supply power to a motorized antenna and control wires for changing direction of rotation.

**ANTIOXIDANT**—Retards or prevents degradation of materials exposed to oxygen (air).

**APPLIANCE WIRING MATERIALS (AWM)**—A classification covering insulated wire and cable for internal wiring of appliances and equipment. UL 758 is the AWM standard. AWM comes in many different styles.

**APPARENT POWER**—The product of the voltage and amperage (VA) in a system. Wiring must be sized to handle the apparent power, and utilities charge extra for loads that require large amounts of reactive power. For this reason, large industrial loads are often power factor corrected using large capacitors to prevent drawing the reactive power needed from the utility distribution system, instead drawing from the capacitors and presenting a less reactive load to the grid.

**ARAMID YARN**—Strength elements that provide tensile strength, support and additional protection for fiber bundles. Kevlar is a brand name of aramid fiber.

**ARC RESISTANCE**—The ability of a material to resist the action of a high-voltage electrical arc, usually stated in terms of the time required to render the material electrically conductive.

**ARMATURE**—(1) Rotating machinery: the member in which alternating voltage is generated. (2) Electromagnet: the member which is moved by magnetic force.

**ARMOR**—Mechanical protector for cables; usually a helical winding of metal tape, formed so each convolution locks mechanically upon the previous one (interlocked armor); may be a formed metal tube (CCW) or a helical wrap of wires.

**ARMOR-X**—Southwire's trademark for CCW aluminum armor.

**ARRHENIUS PLOT**—A statistical method used to predict time-to-failure, based on a device's performance at different temperatures. One method for generating this plot is given in IEEE Standard 101.

**ASCII**—American National Standard Code for Information Interchange. A seven bit plus parity code established by the American National Standards Institute to achieve compatibility among data services and consisting of 96 displayed upper and lower case characters and 32 hidden control codes.

**ASKAREL**—Synthetic insulating oil that is nonflammable but very toxic. It has been replaced by silicone oils.

**ASME**—The American Society of Mechanical Engineering, a not-for-profit professional organization.

**ASTM**—American Society for Testing and Materials. An organization that sets standards on various material tests for industry.

**ATTENUATION**—The decrease in magnitude of a signal as it travels through any transmitting medium, such as a cable, circuitry or free air. Attenuation is measured as a ratio or as the logarithm of a ratio (decibel).

**ATTENUATION CONSTANT**—A rating for a cable or other transmitting medium, which is the relative rate of amplitude decrease of voltage or current in the direction of travel. It is measured in decibels per unit length of cable.

**AUDIO**—A term used to describe sounds within the range of human hearing. Also used to describe devices that are designed to operate within this range.

**AUDIO FREQUENCY**—The range of frequencies audible to the human ear. Usually 20–20,000 Hz.

**AUI**—Attachment unit interface. The interface between the Ethernet/IEEE 802.3 controller and the baseband transceiver or broadband modem.

**AWG**—American Wire Gauge. A common wire diameter specification.

**AWM**—Appliance Wiring Material. A UL 758 designation for a type of wire.

## B

**BACKBONE**—The main portion of network cabling, connecting equipment rooms or communications closets. These cables often have the largest number of fibers and/or the longest continuous cable runs.

**BACKFILL**—The materials used to fill an excavation, such as sand in a trench.

**BALANCED CIRCUIT**—A circuit so arranged that the impressed voltages on each conductor of the pair are equal in magnitude but opposite in polarity with respect to ground.

**BALANCED LINE**—A cable having two identical conductors with the same electromagnetic characteristics in relation to other conductors and to ground.

**BALLAST**—A device designed to stabilize current flow.

**BAND MARKING**—A continuous circumferential band applied to a conductor at regular intervals for identification.

**BANDWIDTH**—The width of a communications channel, measured as frequency (in cycles per second, or hertz). A channel's bandwidth is a major factor in determining how much information it can carry.

**BARE CONDUCTOR**—A conductor having no insulation or jacket.

**BARREL-PACKED**—Method of coiling wire into a drum for shipment.

**BASEBAND**—A signaling technique in which the signal is transmitted in its original form and not changed by modulation.

**BASEBAND LAN**—A local area network employing baseband signaling.

**BEDDING**—A layer of material applied to a cable immediately below the armoring.

**BELDFOIL**—Belden trademark for a highly effective electrostatic shield using reinforced metallic foil.

**BELT**—Layers of insulation on a conductor, or layers of jacket on a cable.

**BELTED-TYPE CABLE**—Multiple conductor cable having a layer of insulation over the assembled insulated conductors.

**BEND LOSS**—A form of increased attenuation caused by (a) having an optical fiber curved around a restrictive radius of curvature or (b) micro bends caused by minute distortions in the fiber imposed by externally induced perturbations.

**BENDING RADIUS**—The radius of a circle that can be tightly fitted into the inside curvature of a bent wire or cable. Also, half the diameter of a drum around which a wire is wound. The manufacturer or industry standards specify the minimum bending radius for a cable.

**BER**—Bit error rate. The ratio of received bits that are in error, relative to a specific number of bits received; usually expressed as a number referenced to a negative power of 10.

**BIL**—Basic impulse level. The crest value of a lightning impulse voltage of a specified wave shape that a high-voltage cable or termination is required to withstand under specified conditions.

**BIMETALLIC WIRE**—A wire formed of two different metals joined together (not alloyed). It can include wire with a steel core, plated or coated wire.

**BINDER**—A tape or thread used for holding assembled cable components in place.

**BINDING POST**—A device for clamping or holding electrical conductors in a rigid position.

**BIRDCAGE**—The undesirable unwinding of a stranded cable.

**BIT**—Abbreviation for binary digit. A unit of information equal to one binary decision or the designation of one of two possible and equally likely states (such as 1 and 0) of anything used to store or convey information.

**BITS PER SECOND (bps)**—The number of bits of data transmitted through a digital process control cable in one second.

**BNC**—Common connector for coax. BNC is said to be an abbreviation for Bayonet-Neill-Concelman.

**BONDED CABLE**—Cable consisting of preinsulated conductors or multiconductor components laid in parallel and bonded into a flat cable.

**BONDED CONSTRUCTION**—An insulation construction in which the glass braid and nylon jacket are bonded together.

**BONDING**—The method used to produce good electrical contact between metallic parts of any device. Used extensively in automobiles and aircraft to prevent static buildup. Also refers to the connectors and straps used to ground equipment.

**BOOSTER**—A device inserted into a line (or cable) to increase the voltage. Boosting generators are also used to raise the level of a DC line. Transformers are usually employed to boost AC voltages. The term booster is also applied to antenna preamplifiers.

**BOOT**—(1) Protective coating over a cable, wire or connector in addition to the normal jacketing or insulation. (2) A form placed around the wire termination of a multicontact connector to contain the liquid potting compound before it hardens.

**BORDER LIGHT CABLE**—Same as stage cable but more than two conductors. Type SO cable is often used.

**BORE HOLE CABLE**—Power and/or communications cable suspended down a vertically drilled hole to equipment underground.

**BRAID**—Textile or metallic filaments interwoven to form a tubular structure that may be applied over one or more wires or flattened to form a strap.

**BRAID ANGLE**—The smaller of the angles formed by the shielding strand and the axis of the cable being shielded.

**BRAID CARRIER**—A spool or bobbin on a braiding machine that holds one group of strands or filaments consisting of a specific number of ends. The carrier revolves during braiding operations.

**BRAID ENDS**—The number of strands used to make up one carrier. The strands are wound side by side on the carrier bobbin and lie parallel in the finished braid.

**BRAIDING MACHINE**—Machine used to apply braids to wire and cable and to produce braided sleeving and braids for tying or lacing purposes. Braiding machines are identified by the number of carriers.

**BRANCH JOINT**—A cable joint used for connecting one or more cables to a main cable.

**BRAZING**—The joining of ends of two wires, rods, or groups of wires with nonferrous filler metal at temperatures above 800°F (427°C).

**BREAKDOWN (PUNCTURE)**—A disruptive discharge through insulation.

**BREAKDOWN VOLTAGE**—The voltage at which the insulation between two conductors breaks down and becomes conductive.

**BREAKING STRENGTH**—The maximum force that a conductor can withstand when tested under tension to rupture.

**BREAKOUT**—The point at which a conductor or group of conductors breaks out from a multiconductor cable to complete circuits at various points along the main cable.

**BRIDGE**—A circuit that measures by balancing four impedances through which the same current flows:

- Wheatstone measures resistance
- Kelvin measures low resistance
- Schering measures capacitance, dissipation factor, dielectric constant
- Wien measures capacitance, dissipation factor

**BRIDGED TAP**—Multiple appearances of the same cable pair at several distribution points (e.g., a telephone party line).

**BRITISH STANDARD WIRE GAUGE**—A modification of the Birmingham Wire Gauge and the legal standard of Great Britain for all wires. Also known as Standard Wire Gauge (SWG), New British Standard (NBS), English Legal Standard and Imperial Wire Guide.

**BROADBAND LAN**—LAN that uses FDM (frequency division multiplexing) to divide a single physical channel into a number of smaller independent frequency channels. The different channels created by FDM can be used to transfer different forms of information: voice, data and video.

**BROADCAST**—The act of sending a signal to all possible receivers in a system.

**B and S**—Brown and Sharpe wire gauge—same as AWG.

**BSL (BASIC SWITCHING IMPULSE INSULATION LEVEL)**—The crest value of a switching impulse voltage of a specified wave shape in which a high-voltage cable termination is required to withstand under specified conditions.

**BUFFER**—A protective coating in intimate contact with an optical fiber.

**BUFFER TUBE**—A loose, crush-resistant polymer tube applied over optical fibers to provide mechanical protection.

**BUILDING WIRE**—Commercial wires used in the building trades because they are independently tested and listed in the National Electric Code, such as types RHH, RHW, THW and THHN wire.

**BUNA**—A synthetic rubber insulation of styrene butadiene; was known as GR-S, now known as SBR (Styrene Butadiene Rubber).

**BUNCH STRAND**—A conductor arrangement in which all individual wires are twisted in the same direction without regard for geometrical arrangement.

**BUNCHER**—A machine that twists wires together in a random arrangement.

**BUOYANT CABLE**—Originally military type MIL-C-2401 with built-in floatation ability. Many power and communications applications using numerous types and sizes have been developed using buoyancy.

**BURIED CABLE**—A cable installed directly in the earth without use of underground conduit. Also called “direct burial cable.”

**BUS**—A network topology in which a signal line is shared by a number of nodes using rules to control traffic on the bus.

**BUS-BAR WIRE**—Uninsulated tinned copper wire used as a common lead.

**BUSHING**—A mechanical device used as a lining for an opening to prevent abrasion to wire and cable.

**BUTT SPLICE**—A splice wherein two wire ends butt against each other, or against a stop, in the center of a splice.

**BUTT WRAP**—Tape wrapped around an object or conductor in an edge-to-edge condition.

**BUTYL RUBBER**—Synthetic rubber formerly used for electrical insulating purposes.

**BX**—A common type of armored building wire rated 600 volts.

**BYTE**—Generally, an 8-bit quantity of information, used mainly in referring to parallel data transfer, semiconductor capacity and data storage; also generally referred to in data communications as an octet or character.

## C

**C**—Symbol for capacitance and Celsius.

**CABLE**—A cable may be a small number of large conductors or a large number of small conductors cabled together, usually color coded and with a protective overall jacket.

**CABLE ASSEMBLY**—A cable assembly is a cable with plugs or connectors on each end for a specific purpose. It may be formed in various configurations.

**CABLE, BELTED**—A multiconductor cable having a layer of insulation over the assembled insulated conductors.

**CABLE CLAMP**—A device used to give mechanical support to the wire bundle or cable at the rear of a plug or receptacle.

**CABLE CLAMP ADAPTER**—A mechanical adapter that attaches to the rear of a plug or receptacle to allow the attachment of a cable clamp.

**CABLE CORE**—The portion of an insulated cable lying under a protective covering.

**CABLE CORE BINDER**—A wrapping of tapes or cords around the conductors of a multiple-conductor cable used to hold them together.

**CABLE FILLER**—The material used in multiple-conductor cables to occupy the interstices formed by the assembly of the insulated conductors, thus forming a cable core.

**CABLE JOINT**—A completely insulated splice, or group of insulated splices, contained within a single protective covering or housing. In some designs, the insulating material may also serve as the protective covering.

**CABLE LOSS**—The amount of RF (radio frequency) signal attenuated by coaxial cable transmission. The cable attenuation is a function of frequency, media type and cable length. For coaxial cable, higher frequencies have greater loss than lower frequencies and follow a logarithmic function. Cable losses are usually calculated for the highest frequency carried on the cable.

**CABLE, PRESSURIZED**—A cable having a pressurized fluid (gas or oil) as part of the insulation; nitrogen and oil are the most common fluids.

**CABLE SHEATH**—The protective covering applied to cables.

**CABLE SUPPORT**—A device to mount a cable on a supporting member.

**CABLING**—The method by which a group of insulated conductors is mechanically assembled (or twisted together).

**CAD**—Computer-aided design.

**CAM**—Computer-aided manufacture.

**CAPACITANCE**—Capacitance is that property of a system of conductors and dielectrics that permits the storage of electricity when potential differences exist between the conductors.

**CAPACITANCE, DIRECT**—The capacitance measured from one conductor to another conductor through a single insulating layer.

**CAPACITANCE, MUTUAL**—The capacitance between two conductors (typically of a pair) with all other conductors, including shield, short circuited to ground.

**CAPACITANCE, UNBALANCED**—An inequality of capacitance between the wires of two or more pairs that result in a transfer of unwanted signal from one pair to others.

**CAPACITANCE, UNBALANCED-TO-GROUND**—An inequality of capacitance between the ground capacitance of the conductors of a pair, which results in a pickup of external noise energy, usually from power transmission lines.

**CAPACITIVE COUPLING**—Electrical interaction between two conductors caused by the potential difference between them.

**CAPACITIVE REACTANCE**—The opposition to alternating current due to the capacitance of a capacitor, cable or circuit. It is measured in ohms and is equal to  $1/(2\pi f C)$  where  $f$  is the frequency in Hz and  $C$  is the capacitance in farads.

**CAPACITOR**—Two conducting surfaces separated by a dielectric material. The capacitance is determined by the area of the surface, type of dielectric and spacing between the conducting surfaces.

**CAPILLARY ACTION**—Movement of a liquid along a small interstice due to surface tension.

**CARRIER**—(1) An AC electrical signal that is used to carry information. (2) The woven element of a braid consisting of one or more ends (strands) which creates the interlaced effect. (3) A spindle, spool, tube, or bobbin (on a braiding machine) containing yarn or wire, employed as a braid.

**CATHODE**—(1) The negative electrode through which current leaves a nonmetallic conductor, such as an electrolytic cell. (2) The positive pole of a storage battery.

**CATHODIC PROTECTION**—Reduction or prevention of corrosion by making the metal to be protected the cathode in a direct current circuit.

**CATV**—Community Antenna Television. Refers to the use of a coaxial or fiber cable to transmit television or other signals to subscribers from a single head-end location.

**CATV CABLE**—General term for all cables used for community antenna TV service and feeders, distribution and house drops.

**CB**—Citizens band. A type of two-way radio communication.

**C CONDITIONING**—A type of line conditioning that controls attenuation, distortion and delay distortion to within specific limits.

**C CONNECTOR**—A bayonet-locking connector for coax; C is named after Carl Concelman.

**CCTV**—Closed-circuit television. One of the services often found on broadband networks.

**CCW**—Continuously corrugated and welded. A type of cable armor.

**CD**—Carrier detect. An RS-232 control signal (on Pin 8) that indicates that the local modem is receiving a signal from the remote modem. Also called received line signal detector (RLSD) and data carrier detect (DCD).

**GENELEC**—Comité Européen de Normalisation Electrotechnique. One of the European Union's key electrical standards bodies.

**CELLULAR POLYETHYLENE**—Expanded or "foam" polyethylene, consisting of individual closed cells of inert gas suspended in a polyethylene medium, resulting in a desirable reduction of dielectric constant.

**CERTIFICATE OF COMPLIANCE**—A written statement normally generated by a quality control department that states that the product being shipped meets a particular specification.

**CERTIFIED TEST REPORT (CTR)**—A report reflecting actual test data on the cable shipped. Tests are normally conducted by the quality control department and show that the product being shipped meets the required test specifications.

**CFR**—Code of Federal Regulations.

**CHANNEL**—(1) A path for electrical transmission. Also called a circuit facility, line, link or path. (2) A specific and discrete bandwidth allocation in the radio frequency spectrum (for example, in a broadband LAN) used to transmit one information signal at a time.

**CHANNEL TRANSLATOR**—Device used in broadband LANs to increase carrier frequency, converting upstream (toward the head-end) signals into downstream signals (away from the head-end).

**CHARACTERISTIC IMPEDANCE**—An electrical characteristic of transmission lines. When terminated in its characteristic impedance, reflections from the end of a line are minimized.

**CHEMICAL STRIPPING**—Removal of insulation by chemical means.

**CHLOROSULFONATED POLYETHYLENE (CSP)**—A rubbery polymer used for insulations and jackets. Previously manufactured by E.I. DuPont under the trade name of Hypalon.

**CI CABLE**—Circuit Integrity cable. An optional rating for UL Listed cable types that meet the two-hour fire survival requirements of UL Standard 2196, e.g., FPLP-CI.

**CIC CABLE**—Circuit Integrity in Conduit cable. A generic term for cables that meet the two-hour fire survival requirements of UL Standard 2196 when installed in metallic conduit per UL category FHH.

**CIGARETTE WRAP**—Tape insulation wrapped longitudinally instead of spirally over a conductor.

**CIRCUIT SWITCHING**—A switching technique in which an information path (i.e., circuit) between calling and receiving stations is established on demand for exclusive use by the connected parties until the connection is released.

**CIRCUIT TRACING**—Locating or identifying a specific conductive path.

**CIRCULAR MIL (CM)**—A term universally used to define cross-sectional areas of conductors. It is an area equal to the area of a circle 1/1000 of an inch in diameter. As the number of circular mils increase, the size of a wire increases.

**CLAD WIRE**—Different from coated wire, clad wire is any metal covered with a relatively heavy coating of different metal, such as copperweld (copper over steel) or alum-o-weld (aluminum over steel). See COATED WIRE.

**CLOSED CELL**—Foamed or cellular material with intact cell walls, usually filled with air. Generally harder, better insulating, but more expensive than open cell material.

**COATED WIRE**—Any metal covered by a relatively thin coating of a different metal such as tin, zinc or other alloy by a dip bath and wipe process, often at high speeds in line with insulating equipment. See TINNED WIRE.

**COAXIAL CABLE**—A cylindrical transmission line comprised of a conductor centered inside a metallic tube or shield, separated by a dielectric material and usually covered by an insulating jacket.

**COHERENT SOURCE**—A fiber optic light source that emits a very narrow, unidirectional beam of light of one wavelength (monochromatic).

**COIL EFFECT**—The inductive effect exhibited by a spiral wrapped shield, especially above audio frequencies.

**COLD BEND**—Generally refers to a test to determine cable or wire characteristics at low temperatures. The test specimen is cooled in a low-temperature box to a specified temperature. The wire specimen is then wound around a mandrel after which it is examined for cracks or other defects caused by bending at low temperatures.

**COLD-DRAWING**—Reducing the cross section by pulling through a die or dies, at a temperature lower than the recrystallization temperature.

**COLD FLOW**—Permanent deformation of the insulation due to mechanical pressure (not due to heat softening).

**COLOR CODE**—A color system for wire or circuit identification by use of solid colors, tracers, braids, surface printing, etc.

**COMBINATION STRANDED CONDUCTOR**—A conventional concentric conductor in which the wires in the outer layer are larger in diameter than the wires in the inner layer or layers and the diameters of all wires are within plus and minus 5 percent of the nominal wire diameter for the same size noncombination stranded conductor.

**COMMON AXIS CABLING**—In multiconductor constructions, a twisting of all conductors about a “common axis” to result in smaller diameter constructions. Tends to result in greater susceptibility to electromagnetic and electrostatic interference.

**COMMON MODE NOISE**—Noise caused by a difference in ground potential. By grounding at either end rather than both ends (usually grounded at source) one can reduce this interference.

**COMPACT STRANDED CONDUCTOR**—A unidirectional or conventional concentric conductor manufactured to a specified diameter, approximately 8 to 10 percent below the nominal diameter of a noncompact conductor of the same cross-sectional area.

**COMPOSITE CABLE**—A cable containing more than one gauge size or a variety of circuit types, e.g., pairs, triples, quads, coaxials, etc.

**COMPOSITE (CLAD) WIRE**—A wire having a core of one metal with a fused outer shell of a different metal.

**COMPOSITE CONDUCTOR**—A conductor consisting of two or more types of wire, each type of wire being plain, clad, or coated-stranded together to operate mechanically and electrically as a single conductor.

**COMPRESSED STRANDED CONDUCTOR**—A conventional concentric conductor manufactured to a diameter not more than 3 percent below the nominal diameter of a noncompressed conductor of the same cross-sectional area.

**COMPRESSION LUG OR SPLICE**—A connection installed by compressing the connector onto the strand, ideally creating a cold weld.

**CONCENTRICITY**—The measurement of the location of the center of the conductor with respect to the geometric center of the circular insulation.

**CONCENTRIC-LAY CONDUCTOR**—A layer of uninsulated wires twisted around a central wire with subsequent layers spirally wrapped around the inner layers to form a single conductor.

**CONDUCTANCE**—The ability of a conductor to carry an electric charge. The ratio of the current flow to the potential difference causing the flow. The reciprocal of resistance.

**CONDUCTIVITY**—Capacity of a material to carry electrical current—usually expressed as a percentage of copper conductivity (copper being 100 percent).

**CONDUCTOR**—A material suitable for carrying an electric current. Several types are as follows:

**COMPACT ROUND CONDUCTOR**—A conductor constructed with a central wire surrounded by one or more reshaped (nonround) helically-laid wires and formed into final shape by rolling, drawing or other means.

**CONCENTRIC-LAY CONDUCTOR**—A conductor constructed with a central wire surrounded by one or more layers of helically-laid wires.

**CONVENTIONAL CONCENTRIC CONDUCTOR**—A conductor constructed with a central wire surrounded by one or more layers of helically-laid wires. The direction of lay is reversed in successive layers and generally with an increase in length of lay for successive layers.

**EQUILAY CONDUCTOR**—A conductor constructed with a central wire surrounded by more than one layer of helically-laid wires, all layers having a common length of lay, direction of lay being reversed in successive layers.

**PARALLEL CORE CONDUCTOR**—A conductor constructed with a central core of parallel-laid wires surrounded by one layer of helically-laid wires.

**ROPE-LAY CONDUCTOR**—A conductor constructed of a bunch-stranded or a concentric-stranded member or members, as a central wire, around which are laid one or more helical layers of such members.

**UNIDIRECTIONAL CONDUCTOR**—A conductor constructed with a central wire surrounded by more than one layer of helically-laid wires, all layers having a common direction of lay, with increase in length of lay for each successive layer.

**UNILAY CONDUCTOR**—A conductor constructed with a central wire surrounded by more than one layer of helically-laid wires, all layers having a common length and direction of lay.

**CONDUCTOR CORE**—The center strand or member about which one or more layers of wires or members are laid helically to form a concentric-lay or rope-lay conductor.

**CONDUCTOR SHIELD**—A conducting layer applied to make the conductor a smooth surface in intimate contact with the insulation; sometimes called Extruded Strand Shield (ESS).

**CONDUIT**—A tube or trough for protecting electrical wires or cables. Also referred to as raceway.

**CONNECTION, DELTA**—Interconnection of three electrical equipment windings in a DELTA (triangular) configuration.

**CONNECTION, WYE**—Interconnection of three electrical equipment windings in WYE (star) configuration.

**CONNECTOR**—A metallic device of suitable electric conductance and mechanical strength, used to splice the ends of two or more cable conductors, or as a terminal connector on a single conductor. Conductors are sometimes spliced without connectors, by soldering, brazing, or welding. Connectors usually fall into one of the following types:

- Solder
- Welded
- Mechanical
- Compression or indent

**CONTACT**—The part of a connector that carries the electrical current.

**CONTACT SIZE**—The largest size wire that can be used with the specific contact. Also, the diameter of the engagement end of the pin.

**CONTINUITY CHECK**—A test performed on a length of finished wire or cable to determine if an electrical current flows.

**CONTINUOUS VULCANIZATION**—Simultaneous extrusion and vulcanization (cross-linking) of wire insulating and jacketing materials. Also referred to as CV cured.

**CONTRAHELICAL**—Wire strands spiraling in an opposite direction than the preceding layer within a wire or cable.

**CONTROL CABLE**—A cable used for remote control operation of any type of electrical power equipment.

**CONTROLLED IMPEDANCE CABLE**—A package of two or more insulated conductors where impedance measurements between respective conductors are kept essentially constant throughout the entire length.

**COPOLYMER**—A compound resulting from the polymerization of two different monomers.

**COPPER-CLAD STEEL**—Steel with a coating of copper welded to it before drawing as opposed to copper-plated. Synonymous with Copperweld.

**COPPERWELD**—Trademark of Copperweld Steel Co. for copper-clad steel conductor.

**CORD**—A flexible insulated cable.

**CORD SET**—Portable cords fitted with a connector at one or both ends.

**CORE**—(1) In cables, a component or assembly of components over which other materials are applied, such as additional components, shield, sheath or armor. (2) In fiber optics, the transparent glass or plastic section with a high refractive index through which the light travels by internal reflections.

**CORONA**—A discharge due to ionization of the air around a conductor due to a potential gradient exceeding a certain critical value. See PARTIAL DISCHARGE.

**CORONA RESISTANCE**—The time that the insulation will withstand a specified level of ionization that does not result in the complete breakdown of the insulation.

**CORROSION**—The destruction of the surface of a metal by chemical reaction.

**COULOMB**—The derived SI unit for quantity of electricity or electrical charge: one coulomb equals one ampere-second.

**COUNTER EMF**—The voltage opposing the applied voltage and the current in a coil; caused by a flow of current in the coil; also known as back EMF.

**COUNTERPOISE WIRE**—Bare copper wire used to offset the impact of lightning surges along high-voltage overhead lines and around the base of towers. Buried counterpoise wire is connected to overhead ground wires and towers. Numerous methods of application are used, dependent upon resistance of the soil at the tower base.

**COUPLING**—The transfer of energy between two or more cables or components of a circuit.

**COUPLING LOSS**—Signal losses in an optical fiber due to small differences in numerical aperture, core diameter, core concentricity and tolerances in connectors when two fibers are spliced together. Also known as splicing loss and transfer loss.

**COVERAGE**—The calculated percentage that defines the completeness with which a metal braid covers the underlying surface. The higher percentage of coverage, the greater the protection against external interference.

**CPE**—Chlorinated polyethylene. A jacketing compound sold by Dow Chemical under the trademark Tyrin.

**CROSS-LINKED**—Intermolecular bonds created between long-chain thermoplastic polymers by chemical or electron bombardment means. The properties of the resulting thermosetting material are usually improved.

**CROSS-LINKED POLYETHYLENE**—A dielectric material used for insulating and jacketing. Also referred to as “XLP” or “XLPE.”

**CROSSTALK**—A type of interference caused by audio frequencies from one circuit being coupled into an adjacent circuit. The term is loosely used to also include coupling at higher frequencies.

**CRT**—Cathode-ray tube. A television-like picture tube used in terminals; CRT is commonly used as a synonym for the CRT terminal.

**CRT WIRE**—High-voltage lead wire for energizing cathode-ray tubes.

**CSA (CANADIAN STANDARDS ASSOCIATION)**—Standards body for Canada, similar to UL in the United States.

**CSA Certified**—A product that has been tested and found to comply with applicable Canadian standards.

**CSPE**—A jacketing compound based on DuPont's chlorosulfonated polyethylene (Hypalon). Sometimes abbreviated CSP.

**CT**—Cable Tray, from NEC Article 392. A cable marking that indicates a cable is suitable for use in a cable tray.

**CURE**—To change the properties of a polymeric material into a more stable, usable condition by the use of heat, radiation or reaction with chemical additives.

**CURING CYCLE**—The time, temperature and pressure required for curing.

**CURL**—The degree to which a wire tends to form a circle after removal from a spool.

**CURRENT**—The rate of transfer of electricity. The unit of current is the ampere, a rate of one coulomb/second.

**CURRENT, ALTERNATING (AC)**—An electric current that periodically reverses direction of electron flow. The number of cycles in a given unit of time (generally a second) is called the frequency of the current.

**CURRENT CARRYING CAPACITY**—The maximum current an insulated conductor can safely carry without exceeding its insulation and jacket temperature limitations. Same as ampacity.

**CURRENT, CHARGING**—The current needed to bring the cable up to voltage; determined by the capacitance of the cable. The charging current will be 90° out of phase with the voltage.

**CURRENT DENSITY**—The current per cross sectional area. Usually in units of amperes/square meter.

**CURRENT, DIRECT (DC)**—Electrical current whose electrons flow in one direction only. It may be constant or pulsating as long as their movement is in the same direction.

**CUT-THROUGH RESISTANCE**—The ability of a material to withstand mechanical pressure without damage.

**CV**—Continuous vulcanization. An insulation and jacketing curing process.

**CYCLE**—The complete sequence, including reversal of the flow, of an alternating electric current.

## D

**D/A**—Digital to analog.

**DAC**—Digital to analog converter. A device that converts a digital input signal to an analog output signal carrying equivalent information.

**DATA**—Digitally represented information including voice, text, images and video.

**dB**—Decibel. The standard unit used to express the relative strength of two signals. When referring to a single signal measured at two places in a transmission system, it expresses either a gain or loss in power between the input and output devices.

**dBmV**—Decibel millivolt. The level at any point in a system expressed in dBs above or below a 1 millivolt/75 ohm standard is said to be the level in decibel-millivolts or dBmV. Zero dBmV is equal to 1 millivolt across an impedance of 75 ohms.

**DC**—Direct current. (see CURRENT, DIRECT.)

**DCE**—Data communications equipment. In common usage, synonymous with modem; the equipment that provides the functions required to establish, maintain and terminate a connection as well as the signal conversion required for communications between the DTE and the telephone line or data circuit.

**DCL**—Data carrier level.

**DC RESISTANCE**—See RESISTANCE.

**DCS**—Distributed control system. A type of industrial automation system in which the processors are distributed in various locations though out the facility.

**DecaBDE**—Decabromodiphenyl ether. A type of brominated flame retardant sometimes used in wire and cable and other products. A type of polybrominated diphenyl ether (PBDE).

**DELAY SKEW**—The difference between the propagation delay of any two pairs within the same cable sheath. Delay skew is caused primarily because twisted pairs are designed to have different twists per foot (lay lengths). Delay skew could cause data transmitted over one channel to arrive out of sync with data over another channel.

**DEMAND**—(1) The measure of the maximum load of a utility's customer over a short period of time. (2) The load integrated over a specified time interval.

**DERATING FACTOR**—A factor used to reduce the current carrying capacity of a wire when used in environments other than that for which the value was established.

**DETECTOR**—A fiber optic device that picks up light from the fiber and converts the information into an electrical signal.

**DIELECTRIC**—An insulating (nonconducting) medium.

**DIELECTRIC BREAKDOWN**—Any change in the properties of a dielectric that causes it to become conductive. Normally the failure of an insulation because of excessive voltage.

**DIELECTRIC CONSTANT**—The property of an insulation which determines the electrostatic energy stored per unit volume for unit potential gradient. It is expressed as a ratio. "K" for air is 1.0, while that for polyethylene is 2.3. Therefore, the capacitance of polyethylene is 2.3 times that of air. It is also referred to as specific inductive capacity or permittivity.

**DIELECTRIC DISPERSION**—The change in relative capacitance due to a change in frequency.

**DIELECTRIC HEATING**—The heating of an insulating material when placed in a radio-frequency field, caused by internal losses during the rapid polarization reversal of molecules in the material.

**DIELECTRIC LOSS**—The power dissipated in a dielectric as the result of the friction produced by molecular motion when an alternating electric field is applied.



**DIELECTRIC STRENGTH**—The maximum voltage that an insulation can withstand without breaking down; usually expressed as a gradient in V/mil (volts per mil). Polyethylene for example has a dielectric strength of about 800 V/mil.

**DIELECTRIC STRENGTH TESTING**—A common test performed on electrical products that is often called hi-pot testing. A voltage higher than normal operating voltage is applied across the insulation. This test can increase product reliability by detecting faulty workmanship.

**DIGITAL**—Refers to communications procedures, techniques and equipment by which information is encoded as either a binary “1” or “0”; the representation of information in discrete binary form, discontinuous in time, as opposed to the analog representation of information in variable, but continuous, waveforms.

**DIN**—Deutsches Institut für Normung (DIN), German standards body.

**DIP COATING**—An insulating coating applied to the conductor by passing the conductor through an applicator containing liquid insulating medium.

**DIRECT BURIAL CABLE**—A cable installed directly in the earth.

**DIRECT CAPACITANCE**—The capacitance measured directly from conductor to conductor through a single insulating layer.

**DIRECTIONAL COUPLER**—A passive device used in a cable system to divide or combine unidirectional RF power sources.

**DIRECTION OF LAY**—The lateral direction, designated as left-hand or right-hand, in which the wires of a conductor run over the top of the conductor as they recede from an observer looking along the axis of the conductor.

**DISPERSION**—The variation of the refractive index of an optical fiber with wavelength, causing light of different wavelengths to travel at different velocities in the fiber.

**DISSIPATION FACTOR**—Energy lost when voltage is applied across an insulation. The cotangent of the phase angle between voltage and current in a reactive component. Dissipation factor is quite sensitive to contamination and deterioration of insulation. Also known as power factor.

**DISTORTION FACTOR**—An undesirable change in waveform as a signal passes through a device.

**DISTRIBUTION CABLE**—(1) In a CATV system, the transmission cable from the distribution amplifier to the drop cable. (2) In an electric power system, provides low-voltage service to the customer.

**DISTURBED CONDUCTOR**—A conductor that receives energy generated by the field of another conductor or an external source such as a transformer.

**DISTURBING CONDUCTOR**—A conductor carrying energy whose field(s) create spurious energy in another conductor.

**DOWNLOAD**—The process of loading software into the nodes of a network from one node or device over the network media.

**DRAIN WIRE**—An uninsulated wire in contact with a shield throughout its length, used for terminating the shield.

**DRAWING**—In wire manufacturing, pulling the metal through a die or series of dies to reduce diameter to a specified size.

**DROP CABLE**—In a CATV system, the transmission cable from the distribution cable to a dwelling.

**DSR**—Data Set Ready. One of the control signals on a standard RS-232-C connector. It indicates whether the data communications equipment is connected and ready to start handshaking control signals so that transmission can start.

**DTE**—Data terminal equipment.

**DTR**—Data terminal ready. An RS-232 modem interface control signal (sent from the DTE to the modem on pin 20) that indicates that the DTE is ready for data transmission and which requests that the modem be connected to the telephone circuit.

**DUAL CABLE**—A two-cable system in broadband LANs in which coaxial cables provides two physical paths for transmission, one for transmit and one for receive, instead of dividing the capacity of a single cable.

**DUCT**—An underground or overhead tube for carrying electrical conductors.

**DUOFOIL**—Belden trademark for a shield in which metallic foil is applied to both sides of a supporting plastic film.

**DUPLEX**—Two-way data transmission on a four-wire transmission cable.

**DUPLEX CABLE**—A cable composed of two insulated single conductor cables twisted together.

## E

**E**—(1) Symbol for voltage. Usually used to represent direct voltage or the effective (root-mean-square) value of an alternating voltage. (2) A UL cable type. Elevator lighting and control cable.

**EARTH**—British terminology for zero-reference ground.

**ECCENTRICITY**—Like concentricity, a measure of the center of a conductor’s location with respect to the circular cross section of the insulation. Expressed as a percentage of displacement of one circle within the other.

**ECTFE**—Ethylene chlorotrifluoroethylene. Halar is a Solvay Solexis trademark for this material. Used as an insulation or jacketing material.

**EDDY CURRENT**—Circulating currents induced in conducting materials by varying magnetic fields.

**ELASTOMER**—Any material that will return to its original dimensions after being stretched or distorted.

**ELECTROMAGNET**—A device consisting of a ferromagnetic core and a coil that produces appreciable magnetic effects only when an electric current exists in the coil.

**ELECTROMAGNETIC**—Referring to the combined electric and magnetic fields caused by electron motion through conductors.

**ELECTROMAGNETIC COUPLING**—The transfer of energy by means of a varying magnetic field. Inductive coupling.



**ELECTRO-MECHANICAL CABLES**—Dual purpose composite cables made up of support strands capable of supporting predetermined loads together with communication, coaxial, or power as integral members of a finished cable.

**ELECTROMOTIVE FORCE (EMF)**—Pressure or voltage. The force that causes current to flow in a circuit.

**ELECTRON**—An elementary particle containing the smallest negative electric charge; charge = 0.16 attocoulomb. Diameter = 1 femtometer.

**ELECTRON VOLT**—A measure of the energy gained by an electron passing through an electric field produced by one volt.

**ELECTRONIC WIRE AND CABLE**—Wire or cable used in electronic applications.

**ELECTRO-OSMOSIS**—The movement of fluids through dielectrics because of electric current.

**ELECTROSTATIC**—Pertaining to static electricity, or electricity at rest. A static electric charge, for example.

**ELECTROSTATIC COUPLING**—The transfer of energy by means of a varying electrostatic field. Capacitive coupling.

**ELECTROSTATIC DISCHARGE (ESD)**—An instantaneous flow of an electrical charge on a nonconductor through a conductor to ground.

**ELECTRO-TINNED**—Electrolytic process of tinning wire using pure tin.

**ELEXAR**—Shell trademark for a thermoplastic elastomer (TPE).

**ELFEXT**—Equal-level far-end crosstalk. A measure of the unwanted signal coupling from a transmitter at the near-end into a neighboring pair measured at the far-end, relative to the received signal level measured on that same pair. Referred to as ACR-F (insertion loss to crosstalk ratio far-end) in the ANSI/TIA-568-B.2-Addendum 10 draft. (ELFEXT is FEXT adjusted to discount insertion loss.)

**ELONGATION**—The fractional increase in the length of a material stressed in tension.

**EMA**—Electrical moisture absorption. A water tank test during which sample cables are subjected to voltage and water maintained at rated temperature; the immersion time is long, with the object being to accelerate failure due to moisture in the insulation; simulates buried cable.

**EMBOSSING**—Identification by means of thermal indentation that leaves raised lettering on the sheath material of cable.

**EMERGENCY OVERLOAD**—A situation in which larger than normal currents are carried through a cable or wire for a limited period of time.

**EMF**—Electromotive force. A force that tends to cause electrons to flow. SI unit is the volt.

**EMI**—Electromagnetic interference. External signals that disrupt the data being transmitted on the local area network or electronic device being operated. Typically, these external signals emanate from universal motors with brushes, fluorescent lights, personal computers, printers or other devices using nonlinear, switch-mode power supplies, etc. The Federal Communications Commission (FCC) regulates these emissions in the U.S.

**ENDOSMOSIS**—The penetration of water into a cable by osmosis; aggravated and accelerated by DC voltage on the cable.

**ENDS**—In braiding, the number of essentially parallel wires or threads on a carrier.

**ENERGIZE**—To apply voltage to a circuit or device in order to activate it.

**EO**—A UL cable type. Elevator lighting and control cable with thermoset insulation.

**EOT**—End of transmission character. A transmission control character used to indicate the end of transmission, which may include one or more texts and any associated message headings.

**EP, EPR, EPM, EPDM**—E-ethylene, P-propylene, M-monomer, D-diene. Designations for a synthetic rubber based upon the hydrocarbon ethylene propylene.

**EPA**—Environmental Protection Agency. The federal regulatory agency responsible for keeping and improving the quality of our living environment—mainly air and water.

**EPDM**—Ethylene propylene diene monomer.

**EPROM**—Erasable programmable read only memory.

**EPR**—Ethylene propylene rubber.

**EQUILAY CONDUCTOR**—See CONCENTRIC-LAY CONDUCTOR.

**ER RATED**—Exposed Run. An optional UL rating on UL Listed cable Types TC, ITC and PLTC that meet the same crush and impact requirements as metal clad (Type MC) cables. Formerly called Open Wiring rated. Permits exposed runs between cable tray and utilization equipment.

**ET**—A UL cable type. Elevator lighting and control cable with thermoplastic insulation, three braids, flame-retardant and moisture-retardant finish. May have steel supporting strand in the center, 300 V.

**ETCHED WIRE**—A process applied to Teflon wire in which the wire is passed through a sodium bath to create a rough surface to allow epoxy resin to bond to the Teflon.

**ETFE**—Ethylene tetrafluoroethylene. Tefzel is DuPont's trademark for this material.

**ETHERNET**—A baseband frame-based networking local area network (LAN) communication standard. Standardized as IEEE 802.3. One of the dominant LAN technologies.

**ETL**—Electrical Testing Laboratories, Inc. An independent testing laboratory that performs testing, similar to UL.

**ETPC**—Abbreviation for electrolytic tough pitch copper. It has a minimum conductivity of 99.9 percent.

**EVA**—Ethylene vinyl acetate. A polymer often used for the jacket in low smoke, zero halogen, flame retardant cables. Often referred to as a polyolefin.

**EXIT ANGLE**—The angle between the output radiation vectors and the axis of the fiber or fiber bundle.

**EXPANDED DIAMETER**—Diameter of shrink tubing as supplied. When heated the tubing will shrink to its extruded diameter.

**EXTERNAL WIRING**—Electronic wiring that interconnects subsystems within the system.

**EXTRUDED CABLE**—Cable that is insulated by applying insulation material in a continuous extrusion process.

**EXTRUSION**—A method of applying insulation to a conductor or jacketing to a cable. The process is continuous and uses rubber, neoprene or a variety of plastic compounds.

## F

**FACSIMILE**—The remote reproduction of graphic material; an exact copy.

**FARAD**—A unit of capacitance when a difference of potential of 1 volt produces a displacement of one coulomb in a capacitor. The farad is a very large unit and much smaller units, like the microfarad ( $\mu\text{F}$ ) or picofarad (pF) are more commonly used.

**FATIGUE RESISTANCE**—Resistance to metal crystallization, which leads to conductors or wires breaking during flexing.

**FAULT, GROUND**—A fault to ground.

**FCC**—Federal Communications Commission.

**FDDI (Fiber Distributed Data Interface)**—An ANSI-defined token-passing ring using fiber optic media to attain a 100 Mbps transmission rate.

**FDX**—Full duplex. Transmission in two directions simultaneously, or, more technically, bidirectional simultaneous two-way communications.

**FEP**—Fluorinated ethylene propylene. Teflon is DuPont's trademark for this material.

**FEPB**—A UL cable type. Fluorinated ethylene propylene insulated wire with glass braid. 14 AWG to 2 AWG, 90°C dry/damp or 200°C dry maximum operating temperature.

**FEXT**—Far-end crosstalk. A measure of the unwanted signal coupling from a transmitter at the near-end into a neighboring pair measured at the far-end.

**FFH-2**—A UL type of heat-resistant rubber-covered fixture wire with flexible stranding. 600 V rating, 18 AWG–16 AWG, 75°C maximum operating temperature.

**FIBER DISPERSION**—Pulse spreading in an optical fiber caused by differing transit times of various modes (a mode is one ray of light).

**FIBER OPTICS**—Transmission of energy by light through glass fibers. A technology that uses light as an information carrier. Fiber optic cables (light guides) are a direct replacement for conventional cable and wire pairs. The glass-based transmission cable occupies far less physical volume for an equivalent transmission capacity; the fibers are immune to electrical interference.

**FIBER TUBING**—A loose, crush-resistant cylinder applied over individual fibers to provide mechanical protection. Also called a buffer tube.

**FIELD COIL**—A suitable insulated winding mounted on a field pole to magnetize it.

**FIELD MOLDED SPLICE**—A joint in which the solid dielectric joint insulation is fused and cured thermally at the job site.

**FIELD TESTS**—Tests that may be made on a cable system after installation as an acceptance or proof test. Various standards with test recommendations exist, like IEEE 400.

**FIGURE 8 CABLE**—An aerial cable configuration in which the conductors and the steel strands that supports the cable are integrally jacketed. A cross section of the finished cable approximates the figure “eight.”

**FILLED CABLE**—A cable construction in which the cable core is filled with a material that will prevent moisture from entering or passing through the cable.

**FILLER**—Fillers are used in multiconductor cables that occupy the interstices formed by the assembled conductors. This is done so that the finished cable will be round.

**FILLING COMPOUND**—A dielectric material poured or injected into a splice housing or cable to prevent the entry of water. Filling compounds may require heating or mixing prior to filling. Some filling compounds may also serve as the insulation.

**FINE STRANDED WIRE**—Stranded wire with component strands of 36 AWG or smaller.

**FLAME RESISTANCE**—The ability of a material to not propagate flame once the heat source is removed.

**FLAMMABILITY**—The measure of a material's ability to support combustion.

**FLASHOVER**—A disruptive discharge around or over the surface of a solid or liquid insulator.

**FLAT BRAID**—A woven braid of tinned copper strands rolled flat at the time of manufacture to a specified width.

**FLAT CABLE**—A cable with two essentially flat surfaces.

**FLAT CONDUCTOR**—A wire having a rectangular cross section as opposed to a round or square conductor.

**FLEX-LIFE**—The measurement of the ability of a conductor or cable to withstand repeated bending, usually specified as expected total number of cycles before failure.

**FLEXIBILITY**—The ease with which a cable may be bent. In general, finer stranding gives greater flexibility. Various types of cables are available depending on the type of flexing required.

**FLEXIBLE**—That quality of a cable or cable component that allows for bending under the influence of an outside force, as opposed to limppness that is bending due to the cable's own weight.

**FLOATING**—Refers to a circuit that has no electrical connection to ground.

**FLUOROPOLYMER**—A class of polymers used as insulating and jacketing materials. Common ones include Teflon, Tefzel, Kynar and Halar.

**FLUX**—(1) The lines of force which make up an electrostatic field. (2) The rate of flow of energy across or through a surface. (3) A substance used to promote or facilitate fusion, commonly used in soldering.

**FM**—Frequency modulation. A modulation technique in which the carrier frequency is shifted by an amount proportional to the value of the modulating signal. The deviation of the carrier frequency determines the signal content of the message.

**FOAMED INSULATION**—Insulations having a cellular structure.

**FOIL**—A thin, continuous sheet of metal. Often used as a shield material in cables.

**FREQUENCY**—The number of cycles per second at which an (electrical) event occurs, expressed in hertz (Hz). One hertz is one cycle per second.

**FREQUENCY ANALYZER**—An instrument to measure the intensity of various component frequencies from a transmitting source. Also referred to as a spectrum analyzer.

**FREQUENCY COUNTER**—An electronic measuring instrument that precisely counts the number of cycles of a periodic electrical signal during a given time interval.

**FREQUENCY MODULATION (FM)**—Method of encoding a carrier wave by varying the frequency of the transmitted signal.

**FREQUENCY PLAN**—Specification of how the various frequencies available in a communications system are allocated for use. In the U.S. the FCC defines uses for various frequency bands.

**“F” TYPE CONNECTOR**—A low-cost connector used by the TV industry to connect coaxial cable to equipment. Used up to 1 GHz.

**FULL DUPLEX**—Two-way communications in which each modem simultaneously sends and receives data at the same rate.

**FUSE WIRE**—Wire made from an alloy that melts at a relatively low temperature to open a circuit when over-current conditions occur.

**FUSED COATING**—A metallic coating that has been melted and solidified, forming a metallurgical bond to the base material.

**FUSED CONDUCTORS**—Individual strands of heavily tinned copper wire stranded together and then bonded together by induction heating.

**FUSED SPIRAL TAPE**—A PTFE insulation often used on hook-up wire. The spiral wrapped tape is passed through a sintering oven where the overlaps are fused together.

## G

**G**—A UL portable power cable type with thermoset insulation and thermoset fiber reinforced oil-resistant jacket. Two to five #8 AWG or larger conductors with ground wires. Rated 2,000 V, 60°C maximum operating temperature when exposed to oil, 90°C maximum dry.

**GALVANIZED STEEL WIRE**—Steel wire coated with zinc.

**GANG STRIP**—Stripping all or several conductors simultaneously.

**GAS FILLED CABLE**—A self-contained pressurized cable in which the pressure medium is an inert gas having access to the insulation.

**GAUGE**—A term used to denote the physical size of a wire. See AWG.

**GAUSS**—A unit of magnetic induction (flux density) equal to 1 Maxwell per square centimeter.

**GENERAL PURPOSE INSTRUMENTATION BUS (GPB)**—A protocol standard defined by the IEEE. Often used on automated test and measurement equipment in manufacturing environments.

**GFCI**—Ground fault circuit interrupter. A protective device that detects abnormal current flowing to ground and then interrupts the circuit. Required by the NEC for some installations.

**G-GC**—A UL cable type. A portable power cable similar to Type G, but also having a ground check (GC) conductor to monitor the continuity of the grounding circuit.

**GHz**—Gigahertz frequency: 1,000,000,000 cycles per second.

**GIGA**—A numerical prefix denoting one billion ( $10^9$ ).

**GLAND**—A device used to terminate, seal and/or ground the metallic armor of a cable as it enters a metal enclosure. Sometimes called a fitting or a connector.

**GND**—Common abbreviation for ground.

**GREEN GOOP**—A viscous liquid that occasionally oozes from the end of installed PVC cables after many years in service. Generally found to be plasticizer (a component of PVC) contaminated with a copper compound that is green in color.

**GROUND**—A voltage reference point that can be the same as earth or chassis ground.

**GROUND CHECK CONDUCTOR (GC)**—An insulated conductor commonly used in mining cables to monitor the health of the grounding conductor(s) in the cable.

**GROUND CONDUCTOR**—A conductor in a transmission cable or line that is grounded.

**GROUND FAULT**—A type of electrical failure in which current flows to ground.

**GROUND LOOP**—The generation of undesirable current flow within a ground conductor, owing to the circulation currents which originate from a second source of voltage.

**GROUND PLANE**—Expanded copper mesh that is laminated into some flat cable constructions as a shield.

**GROUND POTENTIAL**—Zero potential with respect to the ground or earth.

**GROUNDING NEUTRAL**—The neutral wire that is metalically connected to ground.

**GTO**—Gas tube sign cable, UL Listed as single conductor Type GTO-5 (5,000 V), GTO-10 (10,000 V) or GTO-15 (15,000 V), in sizes 18-10 AWG copper. This cable is intended for use with gas-tube systems for signs, outline lighting, and interior lighting.

**GUY**—A tension wire connected to a tall structure and another fixed object to add strength to the structure.

## H

**HALAR**—Solvay Solexis trademark for ethylene chlorotrifluoroethylene (ECTFE).

**HALF DUPLEX**—Two-way communications in which data are sent in only one direction at a time.

**HALOGENATED**—Containing halogen atoms such as chlorine, fluorine, bromine or iodine.

**HALOGENS**—Chemical elements such as chlorine and bromine that when present in a cable are released when burned. These materials can cause damage to human respiratory systems and to electrical equipment.

**HARD-DRAWN WIRE**—As applied to aluminum and copper, wire that has been cold drawn to final size so as to approach the maximum attainable strength.

**HARNESS**—An arrangement of wires and cables, usually with many breakouts, which have been tied together or pulled into a rubber or plastic sheath, used to interconnect an electric circuit.

**HASH MARK STRIPE**—A noncontinuous helical stripe applied to a conductor for identification.

**HAZARDOUS LOCATION**—An area of ignitable vapors, dust, or fibers that may cause fire or explosion as defined in Article 500 of the NEC. Only certain UL cable types are allowed to be used in hazardous in accordance with the NEC.

**HDPE**—High-density polyethylene.

**HDTV**—High-definition television.

**HDX**—Half-duplex transmission. Transmission in either direction but not in both directions simultaneously. Compare with FULL DUPLEX.

**HEAD-END**—A central point in broadband networks that receives signals on one set of frequency bands and retransmits them on another set of frequencies.

**HEAT DISTORTION**—Distortion or flow of a material or configuration due to the application of heat.

**HEAT SEAL**—Method of sealing a tape wrap jacket by means of thermal fusion.

**HEAT SHOCK**—A test to determine stability of material by sudden exposure to a high temperature for a short period of time.

**HEAT SINK**—A device that absorbs heat.

**HEATER CORD**—A group of cable types defined in Article 400 of the NEC such as types HPD, HPN, HS, HSJ, HSJO and HSO.

**HELICAL STRIPE**—A continuous, colored, spiral stripe applied to a conductor for circuit identification.

**HELIX**—Spiral winding.

**HENRY**—A unit of inductance equal to the inductance of a current changing at the rate of 1 ampere per second inducing a counter electromotive force of 1 volt.

**HERTZ (Hz)**—Cycles per second. A cycle that occurs once every second has a frequency of 1 hertz.

**HF**—High frequency.

**HID**—High-intensity discharge, mercury metal halide and sodium lamps.

**HIGH BOND INSULATION**—Insulation exhibiting great bond strength to the conductors.

**HIGH-SPLIT**—A broadband cable system in which the bandwidth used to send toward the head-end (reverse direction) is approximately 6 MHz to 180 MHz and the bandwidth used to send from the head-end (forward direction) is approximately 220 MHz to 400 MHz. The guard band between the forward and reverse directions (180 MHz to 220 MHz) provides isolation from interference.

**HIGH-TEMPERATURE WIRE AND CABLE**—Electrical wire and cables that have maximum operating temperatures of 150°C and higher.

**HIGH-TENSION CABLES**—Generally unshielded high-voltage ignition wires for combustion engines, gas and oil igniters, neon signs, etc. Usually Type GTQ.

**HIGH-VOLTAGE CABLE TERMINATION**—A device used for terminating alternating current power cables having laminated or extruded insulation rated 2.5 kV and above.

**HIGH-VOLTAGE POWER (system voltage ratings)**—A class of system voltages equal to or greater than approximately 69,000 volts or less than 230,000 volts.

**HINGE CABLE**—A cable connected between a hinged or swinging device and a stationary object.

**HIPOT**—A DC high-potential test used on medium- and high-voltage cables. See DIELECTRIC STRENGTH TESTING.

**HL**—Hazardous location. An optional rating for UL Listed Type MC cables. Article 501 of the NEC permits Type MC-HL Listed cables to be used in Class I, Division 1 Hazardous Locations.

**HMWPE**—High molecular weight polyethylene.

**HOLDING STRENGTH**—Ability of a connector to remain assembled to a cable when under tension.

**HOOK-UP WIRE**—Small wires used to hook up instruments or electrical parts, usually 12 AWG and smaller.

**HOT MODULUS**—Stress at 100 percent elongation after 5 minutes of conditioning at a given temperature (normally 130°C).

**HOT STAMPING**—Method of alphanumeric coding. Identification markings are made by pressing heated tape and marking foil into softened insulation surfaces.

**HOT STICK**—A long insulated stick having a hook at one end that is used to open energized switchgear, high-voltage equipment, etc. Allows safe separation of user and high-voltage source.

**HOT TIN DIP**—A process of passing bare wire through a bath of molten tin to provide a coating.

**HOUSING**—A metallic or other enclosure for an insulated splice.

**HPD**—A UL portable heater cord type. 300 V rating with two, three or four 18-12 AWG conductors with thermoset insulation and a cotton or rayon outer covering. For use in dry, nonhard use locations, minimum maximum operating temperature of 90°C.

**HPN**—A UL portable heater cord type with parallel construction. 300 V rating with two or three 18-12 AWG conductors. Oil-resistant thermoset insulation and jacket. For use in nonhard usage and damp locations, minimum maximum operating temperature of 90°C.

**HSJO**—A UL thermoset jacketed heater cord type. 300 V rating with two, three, or four 18-12 AWG conductors. Oil-resistant thermoset insulation and jacket. For use in non-hard usage and damp locations, minimum maximum operating temperature of 90°C.

**HV**—High voltage.

**HYBRID CABLE**—Multiconductor cable containing two or more types of components.

**HYDROSCOPIC**—Used to describe material that absorbs and retains moisture.

**HYPALON**—DuPont's trademark for chlorosulfonated polyethylene (CSP).

**HYPOT**—Registered trade name of Associated Research, Inc. for its high-voltage tester. See HIPOT.

**HYSTERESIS**—The time lag between transitions in state exhibited by a body while reacting to changes in applied forces.

**Hz**—Hertz. A measure of frequency or bandwidth equal to one cycle per second. Named after experimenter Heinrich Hertz.

**I**—Symbol used to designate current. From the French word for current intensity (intensite du courant).

**IACS**—International Annealed Copper Standard for copper used in electrical conductors. 100 percent conductivity at 20°C is 0.017241 ohm-mm<sup>2</sup>/m.

**ICEA**—Insulated Cable Engineers Association. The association of cable manufacturing engineers who publish nationally recognized specifications for cables. Formerly IPCEA.

**IEC**—International Electrotechnical Commission.

**IEEE**—Institute of Electrical and Electronics Engineers. An international professional society that issues its own standards and is a member of ANSI and ISO.

**IEEE 10BASE2 Network**—A network conforming to the IEEE 802.3 local area network standard. The network is capable of carrying information at rates up to 10 Mbps over distances up to 2,800 meters (9,184 feet).

**IEEE 10BROAD36**—10 million bits per second over broadband coaxial cable with node-to-node coverage of 3,600 meters. The IEEE 802.3 specification for running Ethernet on broadband.

**IEEE-488**—An IEEE standard for a parallel interface bus consisting of eight bidirectional data lines, eight control lines and eight signal grounds, which provides for connection to an IEEE-488 device.

**IEEE-802**—Standards for the interconnection of local networking computer equipment. The IEEE-802 standard deals with the Physical Link Layers of the ISO Reference Model for OSI.

**IEEE 802.3**—An IEEE standard describing the physical and data link layers of a local area network based on bus topology and CSMA/CD. Ethernet.

**IEEE 802.5**—A physical layer standard specifying a LAN with a token-passing access method on a ring topology. Token ring.

**IEEE 802.11**—Wireless LAN. (Wi-Fi)

**IEEE 802.15**—Wireless PAN. (Bluetooth)

**IF**—Intermediate-frequency. In a frequency up-converter, this is the frequency between the baseband frequency and the higher frequency RF.

**IMPACT TESTS**—Tests designed to reveal the behavior of material of a finished part if it were subjected to impact or shock loading.

**IMPEDANCE**—The total opposition a circuit, cable or component offers to alternating current. It includes both resistance and reactance (frequency dependent resistance) and is generally expressed in ohms.

**IMPEDANCE MATCH**—A condition whereby the impedance of a particular cable or component is the same as the impedance of the circuit, cable or device to which it is connected. Matched impedances reduce reflections that decrease the power transfer efficiency.

**IMPEDANCE MATCHING STUB**—A section of transmission line or a pair of conductors cut to match the impedance of a load. Also called matching stub.

**IMPEDANCE MATCHING TRANSFORMER**—A transformer designed to match the impedance of one circuit to that of another.

**IMSA**—International Municipal Signal Association.

**IN-BAND SIGNALING**—The transmission of signaling information at some frequency or frequencies that lie within a carrier channel normally used for information transmission.

**INCOHERENT SOURCE**—A fiber optic light source that emits wide, diffuse beams of light of many wavelengths.

**INDEX EDGE**—Edge of a flat (ribbon) cable from which measurements are made, normally indicated by the location of the printing which is near the index edge. Sometimes indicated by a thread or other identification stripe.

**INDOOR TERMINATION**—A cable termination intended for use where it is protected from direct exposure to both solar radiation and precipitation.

**INDUCTANCE**—A property of a conductor or circuit that resists a change in current. It causes current changes to lag behind voltage changes and is measured in henrys.

**INDUCTION**—The phenomenon of a voltage, magnetic field or electrostatic charge being produced in an object by lines of force from an outside source.

**INDUCTION HEATING**—Heating a conducting material by placing it in a rapidly changing magnetic field. The changing field induces electric currents in the material and I<sup>2</sup>R losses account for the resultant heat.

**INDUCTIVE COUPLING**—Crosstalk resulting from the action of the electromagnetic field of one conductor on the other.

**INDUSTRIAL ETHERNET CABLES**—Cables specially designed to withstand the mechanical, chemical and electrical rigors of an industrial environment. Widely used in industrial process control networks.

**INPUT**—(1) A signal (or power) that is applied to a piece of electric apparatus. (2) The terminals on the apparatus to which a signal or power is applied.

**INSERTION LOSS**—A measure of the attenuation of a device by determining the output of a system before and after the device is inserted into the system.

**INSERTION TOOL**—A small, hand-held tool used to insert contacts into a connector.

**INSULATED RADIANT HEATING WIRE**—Similar to blanket wire but heavier construction for applications such as in ceiling panels, buried in ground or driveway and concrete walks.

**INSULATED SPLICE**—A splice with a dielectric medium applied over the connected conductors and adjacent cable insulation.

**INSULATING (ISOLATING) JOINT**—A cable joint that mechanically couples and electrically separates the sheath, shield and armor on contiguous lengths of cable.

**INSULATION**—A material having good dielectric properties that is used to separate close electrical components, such as cable conductors and circuit components.

**INSULATION LEVEL**—A thickness rating for power cable insulation. Circuits having fault detectors that interrupt fault currents within one minute are rated 100 percent level, within one hour are rated 133 percent level and over one hour are rated 173 percent level.

**INSULATION TEMPERATURE RATING**—A maximum operating temperature assigned to insulations based on laboratory testing.

**INSULATION RESISTANCE**—The electrical resistance of an insulating material at a specific time and condition as measured between two conductors.

**INSULATION STRESS**—The potential difference across an insulator. The stress on insulation is expressed in volts per mil (V/m) or kilovolts per meter (kV/m).

**INSULATION THICKNESS**—The wall thickness of wire insulation.

**INSULATION VOLTAGE RATING**—The nominal phase-to-phase operating voltage of a three-phase cable system.

**INTERAXIAL SPACING**—Center-to-center conductor spacing in paired wire or center-to-center spacing between conductors in a flat cable.

**INTERCALATED TAPES**—Two or more tapes helically wound and overlapped on a cable.

**INTERCONNECTING CABLE**—The wiring between modules, units or the larger portions of a system.

**INTERCONNECTION**—The joining of devices mechanically to complete an electrical circuit.

**INTERFACE**—The two surfaces on the contact side of both halves of a multiple-contact connector that face each other when the connector is assembled.

**INTERFERENCE**—Disturbances of an electrical or electromagnetic nature that introduce undesirable responses into other electronic equipment.

**INTERMEDIATE FREQUENCY**—A frequency to which a signal is converted for ease of handling. Receives its name from the fact that it is an intermediate step between the initial and final conversion or detection stages.

**INTERMEDIATE TEMPER**—As applied to aluminum, any temper between soft and hard drawn.

**INTERNAL WIRING**—Electronic wiring that interconnects components, usually within a sealed subsystem.

**INTERSTICE**—The space or void between assembled conductors and within the overall circumference of the assembly.

**INTRINSICALLY SAFE**—Incapable of releasing sufficient electrical or thermal energy under normal or abnormal conditions to cause ignition of a specific hazardous atmospheric mixture in its most ignitable concentration. See Article 504 of the NEC.

**I/O**—Input/Output. The process of transmitting data to and from the processor and its peripherals.

**IONIZATION**—(1) The creation of ions when polar compounds are dissolved in a solvent. (2) When a liquid, gas or solid is caused to lose or gain electrons due to the passage of an electric current.

**IONIZATION FACTOR**—This is the difference between percent dissipation factors at two specified values of electrical stress; the lower of the two stresses is usually so selected that the effect of the ionization on dissipation factor at this stress is negligible.

**IONIZATION VOLTAGE**—The potential at which a material ionizes. The potential at which an atom gives up an electron.

**IR DROP**—A method of designating a voltage drop in terms of both current and resistance.

**IRRADIATION**—In insulations, the exposure of the material to high-energy emissions for the purpose of favorably altering the molecular structure.

**ISDN**—Integrated Services Digital Network. A standard that covers a wide range of data communication issues but primarily the integration of voice and data.

**ISO**—International Organization for Standardization.

**ISO 9000**—A set of quality standards widely used around the world.

**ISOLATION**—The ability of a circuit or component to reject interference, usually expressed in dB.

**ITU**—International Telecommunications Union.

**$I^2R$** —Formula for power in watts, where I = current in amperes, R = resistance in ohms. See WATT.

## J

**JACK**—A plug-in type terminal widely used in electronic apparatus for temporary connections.

**JACKET**—Pertaining to wire and cable, the outer sheath that protects against the environment and may also provide additional insulation.

**JAN SPECIFICATION**—Joint Army-Navy specification (replaced by current military specifications).

**JET STARTER CABLE**—Single conductor 600 V cable used for external aircraft power.

**JITTER**—The slight movement of a transmission signal in time or phase that can introduce errors and loss of synchronization in high-speed synchronous communications.

**JOINT**—That portion of the conductor where the ends of two wires, rods or groups of wires are joined by brazing, soldering, welding or by mechanical means.

**JOULE'S LAW**—When electricity flows through a material the rate of heating in watts will equal the resistance of the material in ohms times the square of the current in amperes.  $W = I^2R$ .

**JUMPER CABLE**—Extra flexible cables with high-voltage insulation for use as temporary connections. Usually has a red jacket.

## K

**KAPTON**—DuPont's trademark for polyimide.

**kB**—Kilobyte. 1,024 bytes. Transmission speeds are measured in kB/second.

**kbps**—Thousands of bits per second (bps).

**kcmil**—One thousand circular mils, replaced "MCM" in the 1990 NEC. Sometimes shortened to "kcm."

**KEVLAR**—A high-strength DuPont polymer used as a cable messenger or strength member.

**K-FIBER**—A polyaramid-based material used for jacketing high-temperature cables.

**KILO**—Prefix meaning thousand.

**kV**—Kilovolt (1,000 volts).

**kVA**—Kilovolt ampere.

**kW**—Kilowatt. 1,000 watts of power.

**KYNAR**—Arkema Inc. trademark for polyvinylidene fluoride (PVDF).

## L

**L**—Symbol for inductance.

**LACING AND HARNESSING**—A method of grouping wires by securing them in bundles of designated patterns.

**LACQUER**—A liquid resin or compound applied to textile braid to prevent fraying, moisture absorption, etc.

**LAMINATED TAPE**—A tape consisting of two or more layers of different materials bonded together.

**LAN**—Local area network. A user-owned, user-operated, high-volume data transmission facility connecting a number of communicating devices within a single building or campus of buildings.

**LASER DIODE**—A semiconductor diode that emits coherent light.

**LAUNCH ANGLE**—The angle between the radiation vector and the axis of an optical fiber.

**LAY**—Pertaining to wire and cable, the axial distance required for one cabled conductor or conductor strand to complete one revolution about the axis around that it is cabled.

**LAY DIRECTION**—The twist in the cable as indicated by the top strands while looking along the axis of the cable away from the observer. Described as "right hand" or "left hand."

**LAYER**—Consecutive turns of a coil lying in a single plane.

**L BAND**—The band of frequencies between 390 and 1,550 megahertz.

**LEACHING AND NONLEACHING**—In a leaching wire the plasticizer will migrate when exposed to heat. A nonleaching wire will retain its plasticizer under extreme temperature conditions and remain flexible after baking.

**LEAD**—A wire, with or without terminals, that connects two points in a circuit.

**LEAD CURED**—A cable that is cured or vulcanized in a metallic lead mold.

**LEAD-IN**—The conductor or conductors that connect the antenna proper to electronic equipment.

**LEAKAGE CURRENT**—An undesirable flow of current through or over the surface of an insulating material.

**LEAKAGE DISTANCE**—The shortest distance along an insulation surface between conductors.

**LED**—Light-emitting diode; device that accepts electrical signals and converts the energy to a light signal; with lasers, the main light source for optical-fiber transmission, used mainly with multimode fiber.

**LENGTH OF LAY**—The axial length of one turn of the helix of a wire or member. See LAY.

**LEVEL**—A measure of the difference between a quantity or value and an established reference.

**LF**—Low frequency. A band of frequencies extending from 30 to 300 kHz in the radio spectrum, designated by the Federal Communications Commission.

**LIFE CYCLE TESTING**—A test to determine the length of time before failure in a controlled, usually accelerated environment.

**LIGHTNING GROUND CABLE**—A specially stranded single conductor cable used to connect lightning rods (air terminals) to grounding rods.

**LIGHT SOURCE**—An object capable of emitting light. In fiber optics, the light source is normally a LED or a laser.

**LIMITS OF ERROR**—The maximum deviation (in degrees or percent) of the indicated temperature of a thermocouple from the actual temperature.

**LIMPNESS**—The ability of a cable to lay flat or conform to a surface.

**LINE BALANCE**—The degree to which the conductors of a cable are alike in their electrical characteristics with respect to each other, to other conductors and to ground.

**LINE DROP**—A voltage loss occurring between any two points in a power transmission line. Such loss, or drop, is due to the resistance, or leakage of the line.

**LINE EQUALIZER**—A reactance (inductance and/or capacitance) connected in series with a transmission line to alter the frequency-response characteristics of the line.

**LINE FAULT**—A fault such as an open circuit, short circuit or ground in an electrical line or circuit.

**LINE LEVEL**—The level of a signal at a certain point on a transmission line. Usually expressed in decibels.

**LINE LOSS**—A total of the various energy losses occurring in a transmission line.



**LINE VOLTAGE**—The value of the potential existing on a supply or power line.

**LITZ WIRE**—Very fine, e.g. #44 AWG bare copper, each strand is enamel insulated. Used for low inductance coil windings.

**LOAD**—A device that consumes or converts the power delivered by another device.

**LOAD CELL CABLE**—Small multiconductor shielded cables for connecting load cells with instruments in electronic strain gauges. Also used for weighing and force measurement applications.

**LOADED LINE**—A transmission line that has lumped elements (inductance or capacitance) added at uniformly spaced intervals. Loading is used to provide a given set of characteristics to a transmission line.

**LOC-TRAC**—Alpha's registered trademark for a zipper tubing closure track that does not require any sealants to keep it closed, even during extreme flexing.

**LOCAL AREA NETWORK (LAN)**—A network that is located in a localized geographical area (e.g., an office, building, complex of buildings, or campus), and whose communications technology provides a high-bandwidth, low-cost medium to which many nodes can be connected.

**LOGGING CABLE**—Usually FEP/Tefzel self-supporting instrumentation cable. Generally dropped through borings in subsurface mining or well applications.

**LONGITUDINAL SHIELD**—A tape shield, flat or corrugated, applied longitudinally with the axis of the cable.

**LONGITUDINAL SHRINKAGE**—A term generally applied to shrink products denoting the axial length lost through heating in order to obtain the recovered diameter.

**LONGITUDINAL WRAP**—Tape applied longitudinally with the axis of the core being covered.

**LONGWALL MACHINE**—A mining machine used to undercut coal.

**LOOP RESISTANCE**—The total resistance of two conductors measured round trip from one end. Commonly used term in the thermocouple industry.

**LOOP TEST**—A long line test where a good line is connected to a faulty line to form a loop in which measurements will locate the fault.

**LOSS**—The portion of energy applied to a system that is dissipated and performs no useful work.

**LOSS FACTOR**—The power factor times the dielectric constant.

**LOW BOND INSULATION**—An insulation that exhibits a small bond strength to the conductors.

**LOW FREQUENCY**—A band of frequencies extending from 30 to 300 kHz in the radio spectrum, designated by the Federal Communications Commission.

**LOW-LOSS DIELECTRIC**—An insulating material that has a relatively low dielectric loss, such as polyethylene or Teflon. Dielectrics with  $\tan \delta$  below 0.01 (approximately) are considered low-loss materials.

**LOW-NOISE CABLE**—A cable specially constructed to eliminate spurious electrical disturbances caused by capacitance changes or self-generated noise induced by either physical movement or adjacent circuitry.

**LOW TENSION**—Low voltage, as applied to ignition cable.

**LOW VOLTAGE**—(1) As defined in the National Electrical Code, a system rated nominal 24 volts or less, supplied from a transformer, converter, or battery. (2) A power system voltage rating of 1,000 volts or less.

**LPF**—Low pass filter. A filter that greatly attenuates signals of higher than a specified frequency, but passes with minimal attenuation all signals lower in frequency.

**LS (LOW SMOKE)**—An optional rating for UL Listed cable types that also pass low smoke requirements contained in UL Standards. A cable that meets the requirements can be marked "LS."

**LSZH**—Abbreviation for low smoke, zero halogen. Sometimes also written LSOH (0=zero).

**LUMEN**—(lm) A SI unit of measurement for light output as perceived by the human eye. Defined as candela-steradians and abbreviated "lm."

**LV**—Low voltage.

## M

**mA**—Milliamper (one-thousandth of an ampere).

**MAGNET WIRE**—Insulated wire used in the windings of motors, transformers and other electromagnetic devices.

**MAGNETIC FIELD**—The field created when current flows through a conductor.

**MAP**—Manufacturing automation protocol. The OSI profile championed by General Motors Corporation to provide interconnectivity between plant hosts, area managers and cell controllers over a broadband token-passing bus network.

**MARKER TAPE**—A tape laid parallel to the conductors under the sheath in a cable, imprinted with the manufacturer's name and the specification to which the cable is made.

**MARKER THREAD**—A colored thread laid parallel and adjacent to the strand in an insulated conductor that identifies the manufacturer and sometimes the specification to which the wire is made.

**MASTIC**—A meltable coating used on the inside of some shrink products that when heated flows to help create a waterproof seal.

**MATV**—Master Antenna Television System. A combination of components providing multiple television receiver operations from one antenna or group of antennas.

**MAXIMUM CABLE DIAMETER**—The largest cable diameter that a high-voltage cable termination is designed to accommodate.

**MINIMUM CABLE DIAMETER**—The smallest cable diameter that a high-voltage cable termination is designed to accommodate.

**MAXIMUM DESIGN VOLTAGE**—The maximum voltage at which a high-voltage cable termination is designed to operate continuously under normal conditions.

**MC**—(1) Main cross-connect. (2) A UL cable type (metal clad).



**MECHANICAL WATER ABSORPTION**—A check of how much water will be absorbed by material in warm water for seven days (mg/sq. in. surface).

**MEDIUM FREQUENCY**—The band of frequencies between 300 and 3,000 kilohertz.

**MEDIUM HARD-DRAWN WIRE**—As applied to copper wire, having tensile strength less than the minimum for hard-drawn wire, but greater than the maximum for soft wire.

**MEDIUM VOLTAGE**—A class of nominal power system voltage ratings between 2.4 and 46 kV.

**MEGA**—Prefix meaning million.

**MEGAHERTZ (MHz)**—One million cycles per second.

**MEGGER**—A special ohmmeter for measuring very high resistance. Primarily used for checking the insulation resistance of cables; however, it is also useful for equipment leakage tests.

**MELT INDEX**—The extrusion rate of a material through a specified orifice under specified conditions.

**MEMBER**—A group of wires stranded together that is in turn stranded into a multiple-membered conductor.

**MESSENGER WIRE**—A metallic supporting member either solid or stranded that may also perform the function of a conductor.

**MFD**—Microfarad (one-millionth of a farad). Obsolete abbreviation.

**MFT**—Abbreviation for 1,000 feet. M is one thousand in the Roman numeral system.

**MG**—Glass reinforced mica tape insulated cable with an overall sheath of woven glass yarn impregnated with a flame, heat and moisture resistant finish. 450°C, 600 V appliance wire.

**MHO**—The unit of conductivity. The reciprocal of an ohm.

**MHz**—Megahertz (one million cycles per second).

**MI**—A UL cable type. One or more conductors insulated with highly compressed refractory minerals and enclosed in a liquid-tight and gas-tight metallic tube sheathing.

**MICA**—A transparent silicate that separates into layers and has high insulation resistance, high dielectric strength and high heat resistance.

**MICRO**—Prefix meaning one-millionth.

**MICROBENDING LOSS**—A signal loss due to small geometrical irregularities along the core-cladding interface of optical fibers.

**MICROFARAD**—One-millionth of a farad (abbreviated  $\mu f$ ).

**MICROMICROFARAD**—One-millionth of a microfarad (abbreviated  $\mu\mu f$ ). Also, a picofarad (pF).

**MICROPHONE CABLE**—A very flexible, usually shielded cable used for audio signals.

**MICROPHONICS**—Noise caused by mechanical movement of a system component. In a single conductor microphone cable, for example, microphonics can be caused by the shield rubbing against the dielectric as the cable is flexed.

**MICROWAVE**—A short (usually less than 30 cm wavelength) electrical wave.

**MID-SPLIT**—A broadband cable system in which the cable bandwidth is divided between transmit and receive frequencies. The bandwidth used to send toward the headend (reverse direction) is approximately 5 MHz to 100 MHz and the bandwidth used to send away from the head-end (forward direction) is approximately 160 MHz to 300 MHz.

**MIL**—A unit of length equal to one-thousandth of an inch (.001 in. = 1 mil).

**MIL-SPEC**—Military specification.

**MIL-DTL-17**—A military specification covering many coaxial cables. Formerly MIL-C-17.

**MIL-DTL-16878**—A military specification covering various wires intended for internal wiring of electric and electronic equipment. Formerly MIL-C-16878.

**MIL-W-22759**—A military specification for fluorocarbon insulated copper and copper alloy wire. Replaced by SAE AS22759.

**MILLI**—Prefix meaning one-thousandth.

**MIPS**—Millions of instructions per second. One measure of processing power.

**MODULATION**—Systematic changing of properties, e.g., amplification, frequency, phase of an analog signal to encode and convey (typically digital) information.

**MODULUS OF ELASTICITY**—The ratio of stress (force) to strain (deformation) in a material that is elastically deformed.

**MOISTURE ABSORPTION**—The amount of moisture, in percentage, that a material will absorb under specified conditions.

**MOISTURE RESISTANCE**—The ability of a material to resist absorbing moisture from the air or when immersed in water.

**MOLDED PLUG**—A connector molded on either end of a cord or cable.

**MONO FILAMENT**—A single-strand filament as opposed to a braided or twisted filament.

**MONOMER**—The basic chemical unit used in building a polymer.

**MOTOR LEAD WIRE**—Wire that connects to the fragile magnet wire found in coils, transformers and stator or field windings.

**MPF**—Mine power feeder cables. Usually rated 5, 8, or 15 kV.

**MSHA**—Mine Safety and Health Administration. The Federal enforcement agency for employee safety in mines and mills. Formerly known as MESA, Bureau of mines. MSHA regulations appear in CFR (Code of Federal Regulations) Title 30, Chapter 1.

**MTW**—Machine tool wire, a UL cable type. Thermoplastic insulated, 90°C to 105°C, 600 V. UL 1063 is the governing standard.

**MULTICAST**—The ability to broadcast messages to one node or a select group of nodes.

**MULTIMODE**—Optical fiber that allows more than one mode (or ray) of light to propagate.

**MULTIPLE-CONDUCTOR CABLE**—A combination of two or more conductors cabled together and insulated from one another and from sheath or armor where used.

**MULTIPLE-CONDUCTOR CONCENTRIC CABLE**—An insulated central conductor with one or more tubular stranded conductors laid over it concentrically and insulated from one another.

**MULTIPLEX**—The use of a common physical channel in order to make two or more logical channels, either by splitting of the frequency band (frequency-division multiplex) or by using this common channel at different points in time (time-division multiplex).

**MULTIPLEXER**—Equipment that permits simultaneous transmission of multiple signals over one physical circuit.

**MULTIPOINT CIRCUIT**—A single line connecting three or more stations.

**MURRAY LOOP TEST**—A method used to localize cable faults.

**MUTUAL CAPACITANCE**—Capacitance between two conductors in a cable.

**MUX**—Multiplex. To transmit two or more signals over a single channel.

**mV**—Millivolt (one-thousandth of a volt).

**MV**—Medium-voltage cables. Usually rated 5–35 kV.

**mW**—Milliwatt (one-thousandth of a watt).

**MYLAR**—DuPont's trademark for polyethylene terephthalate (polyester) film.

## N

**NBR**—Butadiene-acrylonitrile copolymer rubber, a material with good oil and chemical resistance.

**NBR/PVC**—A blend of acrylonitrile-butadiene rubber and polyvinyl chloride (PVC). Used for jacketing.

**NBS**—National Bureau of Standards. Now called NIST (National Institute of Standards and Technology).

**N CONNECTOR**—A threaded connector for coax; N is named after Paul Neill.

**NEC**—National Electrical Code.

**NEGATIVE SEQUENCE IMPEDANCE**—The electrical impedance of a three-phase power cable with the phase rotation reversed as compared to normal operation. Has the same numerical value as the positive sequence impedance. "Negative sequence" refers to the phase relationship of the currents in the conductors.

**NEMA**—National Electrical Manufacturers Association.

**NEOPRENE**—A synthetic rubber with good resistance to oil, chemicals and flame. Also called polychloroprene.

**NETWORK**—A series of nodes connected by communications channels.

**NEWTON**—The derived SI unit for force; the force that will give one kilogram mass an acceleration of one meter per second. Equals 0.2248 pounds force.

**NEXT**—Near-end crosstalk. A measure of the unwanted signal coupling from a transmitter at the near-end into a neighboring (nonenergized) pair measured at the near-end.

**NFPA**—National Fire Protection Association. Publishes the NEC and other codes and standards.

**NICKEL CLAD COPPER WIRE**—A wire with a layer of nickel on a copper core where the area of the nickel is approximately 30 percent of the conductor area.

**NIST**—National Institute of Standards and Technology. Formerly the National Bureau of Standards.

**NM-B**—A UL cable type rated 600 volts and intended for use per Article 334 of the NEC. Nonmetallic sheathed cable. For dry use, 90°C conductor rating.

**NMC-B**—A UL cable type rated 600 volts and intended for use per Article 334 of the NEC. Nonmetallic sheathed cable. Wet or dry use, 90°C conductor rating.

**NODE**—A station or point in a network.

**NOISE**—In a cable or circuit any extraneous sounds or signal that tends to interfere with the sound or signal normally present in or passing through the system.

**NOMEX**—DuPont's trademark for a heat-resistant, flame-retardant nylon.

**NOMINAL**—Name or identifying value of a measurable property by which a conductor or component or property of a conductor is identified and to which tolerances are applied.

**NOMINAL VOLTAGE (NATIONAL ELECTRICAL CODE)**—A nominal value assigned to a circuit or system for the purpose of conveniently designating its voltage class (as 120/240, 480Y/277, 600 volts, etc.). The actual voltage at which a circuit operates can vary from the nominal within a range that permits satisfactory operation of equipment.

**NOMOGRAPH**—A chart or diagram with which equations can be solved graphically by placing a straight edge on two known values and reading the answer where the straight edge crosses the scale of the unknown value.

**NONCONTAMINATING**—A type of PVC jacket material whose plasticizer will not migrate into the dielectric of a coaxial cable and thus avoid contaminating and destroying the dielectric.

**NONCONTAMINATING PVC**—A polyvinyl chloride formulation that does not produce electrical contamination through plasticizer migration.

**NONFLAMMABLE**—The property of a material that is not capable of being easily ignited.

**NONMIGRATING PVC**—Polyvinyl chloride compound formulated to inhibit plasticizer migration.

**NRZI**—Nonreturn to zero inverted. A binary encoding technique in which a change in state represents a binary 0 and no change in state represents a binary 1.

**N-SERIES CONNECTOR**—A coaxial connector (RG-8/U) used in standard Ethernet networks.

**NTSC**—National Television System Committee. Defined the U.S. standard definition color TV standard.

**NUMERICAL APERTURE**—The acceptance angle of an optical fiber that determines the angle at which light can enter the fiber, expressed as a number that is equivalent to the sine of the angle.

**NYLON**—An abrasion-resistant thermoplastic with good chemical resistance. Polyamide.

## O

**O.D.**—Outside diameter.

**OEM**—Original equipment manufacturer.

**OFHC**—Oxygen-free high-conductivity copper.

**OHM**—The electrical unit of resistance. The value of resistance through which a potential difference of one volt will maintain a current of one ampere.

**OHM'S LAW**—Stated  $V = IR$ ,  $I = V/R$ , or  $R = V/I$  where  $V$  is voltage,  $I$  is current in amperes and  $R$  is resistance in ohms.

**OIL AGING**—Cable aged in an accelerated manner by placement in an oil bath and heated to a preset temperature for a stated time.

**OPEN CELL**—Foamed or cellular material with broken cell walls. Air fills in the spaces in the material. Usually softer and less expensive than closed cell material.

**OPEN CIRCUIT**—A break in an electrical circuit so there can be no current flow.

**OPTICAL CONDUCTOR**—Materials that offer a low optical attenuation to transmission of light energy.

**OPTICAL CROSS-CONNECT**—A cross-connect unit used for circuit administration. It provides for the connection of individual optical fibers with optical fiber patch cords.

**OPTICAL ENCODER**—A device whose position is determined by a photoelectric device and converted to an electrical data output.

**OPTICAL FIBER**—Any filament or fiber, made of dielectric materials, that is used to transmit light signals; optical fiber usually consists of a core, which carries the signal and cladding, a substance with a higher refractive index than the core, which surrounds the core and serves to reflect the light signal. See also FIBER OPTICS.

**OPTICAL WAVEGUIDE**—A fiber used for optical communications. Analogous to a waveguide used for microwave communications.

**OSCILLATORY SURGE**—A surge that includes both positive and negative polarity values.

**OSCILLOSCOPE**—Test instrument for visually showing the changes in a varying voltage by means of a line made on a fluorescent screen using the deflection of a beam of cathode rays.

**OSHA**—Abbreviation for Occupational Safety and Health Act. Specifically the Williams-Steiger laws passed in 1970 covering all factors relating to safety in places of employment.

**OSMOSIS**—The diffusion of fluids through membranes.

**OTDR**—Optical time domain reflectometer. A device used for testing and characterization of fiber optic cables.

**OUTDOOR TERMINATION**—A cable termination intended for use where it is not protected from direct exposure to either solar radiation or precipitation.

**OUTGASSING**—Dissipation of gas from a material.

**OUTPUT**—The useful power or signal delivered by a circuit or device.

**OVERALL DIAMETER**—Finished diameter of a wire or cable.

**OVERCOAT CONDUCTOR**—A stranded conductor made from individual strands of tin-coated wire stranded together and then given an overall tin coat.

**OVERLAP**—The amount the trailing edge laps over the leading edge of a spiral tape wrap.

**OXYGEN INDEX**—A test to rate relative flammability of materials in a mixture of oxygen and nitrogen. More formally referred to as limiting oxygen index (LOI). Usually defined as the percentage of oxygen in air required to sustain combustion of the material.

**OZONE**—An extremely reactive form of oxygen, normally occurring around electrical discharges and present in the atmosphere in small but active quantities. In sufficient concentrations it can break down certain insulations.

## P

**PAIR**—Two insulated wires of a single circuit associated together; also known as a “balanced” transmission line.

**PARALLEL CIRCUIT**—A circuit in which identical voltage is presented to all components and the current divides among the components according to the resistances or the impedances of the components.

**PARALLEL STRIPE**—A stripe applied longitudinally on a wire or cable parallel to the axis of the conductor.

**PARALLEL TRANSMISSION**—A type of data transfer in which all bits of a character, or multiple-bit data blocks, are sent simultaneously, either over separate communications lines or circuits, over a single channel using multiple frequencies, or over a multiple-conductor cable.

**PARTIAL DISCHARGE (CORONA) EXTINCTION VOLTAGE**—The voltage at which partial discharge (corona) is no longer detectable on instrumentation adjusted to a specific sensitivity, following the application of a specified higher voltage.

**PATCH CABLE**—A cable with plugs or terminals on each end of the conductors to connect circuits of equipment together. Commonly used in data centers to interconnect computer networking hardware.

**PAYOFF**—The process of feeding a cable or wire from a bobbin, reel or other package. The payoff is the source reel. Wire is fed from a payoff reel onto a take-up reel.

**PBDE**—Polybrominated diphenyl ether. A class of flame retardants sometimes used in wire and cable products. PBDEs are generally banned by European Union RoHS regulations.

**PCB**—Printed circuit board. Also referred to as PWB (printed wiring board) to distinguish this usage from the chemical usage (polychlorinated biphenyls—persistent organic pollutants that are banned in many countries).

**PCP**—Polychloroprene (neoprene).

**PDN**—Public data network. A packet-switched or circuit-switched network available for use by many customers. PDNs may offer value-added services at a reduced cost because of communications resource sharing and usually provide increased reliability due to built-in redundancy.

**PE**—Polyethylene. A widely used thermoplastic insulation and jacket compound.

**PEAK**—The maximum instantaneous value of a varying current or voltage, different from the rms value that is usually used to categorize AC voltages. Also called crest.

**PEEK**—Poly ether ether ketone. A colorless organic thermoplastic used for its robustness.

**PEEL STRENGTH**—The force necessary to peel a flexible member from another member that may be either flexible or rigid.

**PERCENT CONDUCTIVITY**—The ratio of the resistivity of the International Annealed Copper Standard (IACS) at 20°C to the resistivity of a material at 20°C, expressed in percent. Results are calculated on a weight basis or volume basis and so specified.

**PERCENT PLATING**—Quantity of plating on a conductor expressed as a percentage by weight.

**PERCENTAGE CONDUCTIVITY**—Conductivity of a material expressed as a percentage of that of copper.

**PFA**—Perfluoroalkoxy. Teflon is DuPont's trademark for this material.

**PHASE**—The location of a position on a waveform of an alternating current, in relation to the start of a cycle. Measured in degrees, with 360 corresponding to one complete cycle.

**PHASE SEQUENCE**—The order in which successive members of a periodic wave set reach their positive maximum values: a) zero phase sequence—no phase shift; and b) plus/minus phase sequence—normal phase shift.

**PHASE SHIFT**—A change in the phase relationship between two alternating quantities. The phase angle between the input and output signals of a system.

**PHOTOVOLTAIC WIRE (PV WIRE)**—A UL cable type. 600 V, 1,000 V, 2,000 V, insulated, stranded single conductor wire used to connect photovoltaic electricity generating panels to each other and to collection, distribution and utilization equipment.

**PICK**—Distance between two adjacent crossover points of braid filaments. The measurement in picks per inch indicates the degree of coverage.

**PICO**—Prefix meaning one-millionth of one-millionth ( $10^{-12}$ ).

**PICOFARAD**—One-millionth of one-millionth of a farad ( $10^{-12}$ ). A micromicrofarad, or picofarad (abbreviation pF).

**PIGTAIL WIRE**—Fine stranded, extra flexible, rope lay lead wire attached to a shield for terminating purposes.

**PILC CABLE**—Paper insulated, lead covered. Old cable style present in many urban distribution networks. Most are scheduled for replacement due to lead content and age.

**PIN ASSIGNMENT**—A predetermined relationship between the terminals in a connector and the conductors in a cable that specifies the terminals to which each conductor is to be terminated.

**PITCH**—In flat cable, the nominal distance between the index edges of two adjacent conductors.

**PITCH DIAMETER**—Diameter of a circle passing through the center of the conductors in any layer of a multiconductor cable.

**PLANETARY TWISTER**—A cabling machine whose payoff spools are mounted in rotating cradles that hold the axis of the spool in a fixed direction as the spools are revolved so the wire will not kink as it is twisted.

**PLASTICIZER**—A chemical added to plastics to make them softer and more flexible.

**PLATED HOLE**—A hole with walls that have been plated with conductive material to provide an electrical connection between the conductive patterns on both sides of a printed circuit or an anchor for soldering an inserted wire.

**PLC**—Programmable logic controller. A type of industrial control system.

**PLENUM**—The air return path of a central air handling system, either ductwork or open space over a suspended ceiling.

**PLENUM CABLE**—Cable approved by a recognized agency such as UL for installation in plenums without the need for conduit due to a higher flame resistance rating.

**PLTC**—Power limited tray cable, rated 300 volts.

**PLUG**—The part of the two mating halves of a connector that is movable when not fastened to the other mating half.

**PLY**—The number of individual strands or filaments twisted together to form a single thread.

**POINT-TO-POINT WIRING**—An interconnecting technique wherein the connections between components are made by wires routed between connecting points.

**POLARIZATION**—(1) The orientation of a flat cable or a rectangular connector. (2) Orientation of the electric field in an electromagnetic wave. Common characteristic of antennas.

**POLISHING**—Act of smoothing ends of optical fibers to an "optically smooth" finish, generally using abrasives.

**POLYAMIDE**—The chemical name for nylon.

**POLYARAMID**—Generic name for Kevlar. Sometimes also referred to as aramid fiber.

**POLYBUTADIENE**—A type of synthetic rubber often blended with other synthetic rubbers to improve their properties.

**POLYCHLOROPRENE**—See NEOPRENE.

**POLYESTER**—Polyethylene terephthalate, used extensively as a moisture-resistant cable core wrap. Mylar is DuPont's trademark for polyester.

**POLYETHYLENE**—A thermoplastic material having excellent electrical properties.

**POLYHALOCARBON**—A general name for polymers containing halogen atoms. The halogens are fluorine, chlorine, bromine and iodine.

**POLYIMIDE**—A relatively high-temperature plastic developed for use as a dielectric or jacketing material. Kapton is DuPont's trademark for polyimide.

**POLYMER**—A substance made of many repeating chemical units or molecules. The term polymer is often used in place of plastic, rubber or elastomer.

**POLYOLEFINS**—A family of plastics including cross-linked polyethylene and various ethylene copolymers.

**POLYPROPYLENE**—A thermoplastic similar to polyethylene but stiffer and having a higher temperature softening point.

**POLYURETHANE**—Broad class of polymers noted for good abrasion and solvent resistance. Can be in solid or cellular form.

**POLYVINYL CHLORIDE (PVC)**—A general purpose thermoplastic used for wire and cable insulations and jackets.

**POROSITY**—Generally defined as the percentage of space occupied by voids in an insulation cross section.

**PORT**—A point of access into a computer, a network or other electronic device; the physical or electrical interface through which one gains access; the interface between a process and a communications or transmission facility.

**P.O.S.**—Abbreviation for point-of-sale (e.g., a cash register station).

**POSITION CODING**—Identification of conductors by their location, possible only when conductors are located in assigned positions with relation to each other throughout the entire length of a cable.

**POSITIVE SEQUENCE IMPEDANCE**—The electrical impedance of a three-phase power cable during normal operation. A cable parameter used by electrical system engineers to calculate voltage drop. "Positive sequence" refers to the phase relationship of the currents in the conductors.

**POTTING**—Sealing by filling with a substance to exclude moisture.

**POWER**—The amount of work per unit of time. Usually expressed in watts and equal to  $I^2R$  in electrical systems.

**POWER CABLES**—Cables of various sizes, constructions and insulations, single or multiconductor, designed to distribute primary power to various types of equipment.

**POWER FACTOR (PF)**—The cosine of the phase difference between current and applied voltage or the ratio of real power flow to the apparent power flow expressed as a ratio between zero and one. Resistive loads have a power factor of unity. Nonlinear loads have PFs less than one.

**POWER LOSS**—The difference between the total power delivered to a circuit, cable, or device and power delivered by that device to a load.

**POWER RATIO**—The ratio of the power appearing at the load to the input power. Expressed in dB, it is equal to  $10 \log_{10} (P2/P1)$  where P1 is input power and P2 is the power at the load.

**PPE**—Polypropylene ethylene.

**PREBOND**—Stranded wire that has been fused, topcoat tinned or overcoat tinned.

**PREMOLDED SPLICE**—A joint made of premolded components assembled in the field.

**PRIMARY**—The transformer winding that receives the energy from a supply current.

**PRIMARY INSULATION**—The first layer of nonconductive material applied over a conductor, whose prime function is to act as electrical insulation.

**PRINTING WIRING**—A printed circuit intended to provide point-to-point electrical connections.

**PRODUCTION TESTS**—Tests made on components or subassemblies during production for the purpose of quality control.

**PROPAGATION DELAY**—The time it takes a signal, composed of electromagnetic energy to travel from one point to another over a transmission channel; usually most noticeable in communicating with satellites; normally, the speed-of-light delay.

**PROPAGATION TIME**—Time required for a wave or pulse to travel between two points on a transmission line.

**PROPAGATION VELOCITY**—The velocity of the propagation of a wave or pulse along a transmission path.

**PROTECTIVE COVERING**—A field-applied material to provide environmental protection over a splice or housing, or both.

**PROXIMITY EFFECT**—Nonuniform current distribution over the cross-section of a conductor caused by the variation of the current in a neighboring conductor.

**PSAACRF**—Power sum insertion loss to alien crosstalk ratio far-end. A computation of signal coupling from multiple pairs of disturbing channels, to a disturbed pair in another channel measured at the far-end and relative to the received signal level in the disturbed pair at the far-end. Also referred to as power sum alien equal-level far-end crosstalk (PSAELFEXT).

**PSANEXT**—Power sum alien near-end crosstalk. A computation of signal coupling from multiple near-end disturbing channel pairs into a disturbed pair of a neighboring channel or part thereof, measured at the near-end.

**PSAFEXT**—Power sum alien far-end crosstalk. A computation of signal coupling from multiple near-end disturbing channel pairs into a disturbed pair of a neighboring channel or part thereof, measured at the far-end.

**PSNEXT**—Power sum near-end crosstalk. A computation of the unwanted signal coupling from multiple transmitters at the near-end into a neighboring (non-energized) pair measured at the near-end.

**PT**—Thermostat cable with solid conductor, individual insulation, twisted together.

**PTFE**—Polytetrafluorobthylene. One type of Teflon. Sometimes abbreviated TFE.

**PULLING EYE**—A device attached to a conductor to pull cable into or from a duct.

**PULSE**—A current or voltage that changes abruptly from one value to another and back to the original value in a finite length of time.

**PULSE CABLE**—A type of coaxial cable constructed to transmit repeated high-voltage pulses without degradation.

**PVC**—Polyvinyl chloride. A common insulating and jacketing material used on cables.

**PVC-I**—A MIL-DTL-17 coax jacket type. A black polyvinyl chloride with excellent weathering and abrasion properties, but is a contaminating type and will cause cable attenuation to increase with age. Can be used for direct burial.

**PVC-II**—A MIL-DTL-17 coax jacket type. A gray polyvinyl chloride material which is semi-noncontaminating.

**PVC-IIA**—A MIL-DTL-17 coax jacket type. A black or gray polyvinyl chloride material that is noncontaminating. It has good weathering and abrasion-resistant properties and can be used for direct burial.

**PVDF**—Polyvinylidene difluoride. Arkema Inc.'s trademark for this material is Kynar.

**PWB**—Printed wiring board. Replacing PCB in common usage to avoid confusion with chemical PCBs.

**PYROMETER**—See THERMOCOUPLE.

## Q

**Q band**—The band of frequencies between 36 and 46 gigahertz.

**QPL**—A Qualified Products List issued by the U.S. government.

**QUAD**—A series of four separately insulated conductors, generally twisted together in pairs.

## R

**R**—Symbol for electrical resistance.

**RADIO FREQUENCY**—The frequencies in the electromagnetic spectrum that are used for radio communications. A band of frequencies between 10 kilohertz and 100 gigahertz.

**RANDOM WINDING**—A winding in rotating equipment wherein wires do not lie in an even pattern.

**REA (RURAL ELECTRIFICATION ADMINISTRATION)**—A federally supported program to provide electrical service to rural areas. See RUS.

### REACH (REGISTRATION, EVALUATION AND AUTHORIZATION

**OF CHEMICALS)**—A European community regulation on the safe use of chemicals. Companies selling into the European market are required to provide compliance information to their downstream users. Compliance requires the investigation of the supply chain for the presence of certain chemicals called SVHCs (substances of very high concern). REACH began in 2008. Chemicals will be added for a period of several years.

**REACTANCE**—The opposition to an alternating electron flow by a capacitance or inductance. The amount of such opposition varies with the frequency of the current. The reactance of a capacitor decreases with an increase in frequency; the opposite occurs with an inductance.

**RECOVERED DIAMETER**—Diameter of shrinkable products after heating has caused it to return to its extruded diameter.

**RED PLAGUE**—A powdery, brown-red growth sometimes found on silver-coated copper conductors and shield braids.

**REDRAW**—The consecutive drawing of wire through a series of dies to reach a desired wire size.

**REEL**—A revolving flanged device made of plastic, wood or metal, used for winding flexible cable. Also called a spool.

**REFERENCE EDGE**—See INDEX EDGE.

**REFERENCE JUNCTION**—The junction of a thermocouple that is at a known reference temperature. Also known as the "cold" junction, it is usually located at the EMF measuring device.

**REFLECTION**—(1) The change in direction (or return) of waves or pulses striking a surface. For example, electromagnetic energy reflections can occur at an impedance mismatch in a transmission line, causing standing waves. (2) Change in direction of a light wave or ray in an optical fiber.

**REFLECTION LOSS**—The part of a signal that is lost to reflection of power at a line discontinuity.

**REFLOW SOLDERING**—The process of connecting two solder-coated conductive surfaces by remelting of the solder to cause fusion.

**REFRACTION**—The bending of light waves or rays as they go from one material to another due to the difference in velocities in the materials.

**REINFORCED SHEATH**—The outer covering of a cable that has a reinforcing material, usually a braided fiber, molded in place between layers.

**RELIABILITY**—The probability that a device will function without failure over a specified time period or amount of usage.

**RESIN**—A solid or semisolid organic substance, originally of plant origin but largely synthesized now. Resins are broadly classified as thermoplastic or thermoset according to whether they soften or harden with the application of heat.

**RESISTANCE**—In DC circuits, the opposition a material offers to current, measured in ohms. In AC circuits, resistance is the real component of impedance and may be higher than the value measured at DC.

**RESISTIVE CONDUCTOR**—A conductor with high electrical resistance.

**RESISTIVITY**—A material characteristic that opposes the flow of electrical energy through the material. It is affected by temper, temperature, contamination, alloying, etc. The unit of volume resistivity is the ohm-cm. The unit of surface resistivity is ohms/m<sup>2</sup>.

**RESISTOR**—An electronic component designed to have a specific value of resistance.

**RESISTOR COLOR CODE**—A method of indicating resistance value and tolerance. The first color represents the first significant figure of the value. A second color represents the second significant figure and the third is the multiplier or the number of zeros that follow two significant figures. When there is a fourth color band, it indicates the tolerance.

**RESONANCE**—An AC circuit condition in which inductive and capacitive reactance interact to cause a minimum or maximum circuit impedance.

**RETRACTILE CORD**—A cord having a specially treated insulation or jacket so it will retract like a spring. Retractability may be added to all or part of a cord's length.

**RETURN LOSS**—A measure of the degree of impedance mismatch between two impedances. It is the ratio, expressed in decibels, of the amplitude of a reflected wave echo to the amplitude of the main wave at the junction of a transmission line and a terminating impedance.

**RETURN WIRE**—A ground wire or the negative wire in a direct-current circuit.

**REW**—A 600 volt Canadian wire type covered by CSA standards. Made with thermoset insulation.

**RFI**—Radio frequency interference. The disruption of radio signal reception caused by any source that generates radio waves at the same frequency and along the same path as the desired wave. Similar to EMI.

**RF MODEM**—Radio frequency modem. A device used to convert digital data signals to analog signals (and from analog to digital) then modulate/demodulate them to/from their assigned frequencies.

**RG/U**—"RG" (radio guide) is the military designation for coaxial cable and "U" stands for "general utility."

**RHH**—Rubber-insulated, heat-resistant wire, rated 90°C in dry and damp locations. A UL cable type.

**RHW**—Rubber-insulated building wire, heat and moisture-resistant, 75°C dry or wet. A UL cable type.

**RHW-2**—Rubber-insulated building wire, heat and moisture-resistant, 90°C dry or wet. A UL cable type.

**RIBBON CABLE**—A flat cable of individually insulated conductors lying parallel and held together by means of adhesive or an extruded polymer web.

**RIDGE MARKER**—One or more ridges running laterally along the outer surface of a plastic insulated wire for purposes of identification.

**RIGID COAXIAL CABLE**—Nonflexible coaxial cable, usually a metal tube armored coaxial cable. Sometimes called "hardline."

**RINGING OUT**—Locating or identifying specific conductive paths by passing current through selected conductors.

**RING TONGUE**—A solderless terminal that connects wire to a stud.

**RIP CORD**—Two or more insulated conductors in a parallel configuration that may be separated to leave the insulation of each conductor intact.

**RISE TIME**—The time it takes the voltage to rise from 0.1 to 0.9 of its final value.

**RIV**—Radio influence voltage. The radio noise appearing on conductors of electric equipment or circuits.

**rms**—See ROOT MEAN SQUARE.

**ROCKWELL HARDNESS**—A measure of hardness determined by resistance to indentation by a small diamond or steel ball under pressure.

**RoHS**—Restriction of Hazardous Substances. A European Union regulation (Directive 2002/95/EC), which became effective in 2006 that requires the elimination of six hazardous substances from electrical and electronic products sold in the EU including lead, cadmium, mercury, hexavalent chromium, PBB and PBDE.

**ROMEX**—A type of nonmetallic sheathed (Type NM) cable. A trademark of the Southwire Company.

**ROOT MEAN SQUARE (rms)**—The effective value of an alternating current or voltages.

**ROPE CONCENTRIC**—A group of stranded conductors assembled in a concentric manner.

**ROPE-LAY CONDUCTOR**—See CONCENTRIC-LAY CONDUCTOR.

**ROPE STRAND**—A conductor composed of a center group of twisted strands surrounded by layers of twisted strands.

**ROPE UNILAY**—A group of stranded conductors assembled in a unilay manner.

**ROTATING CABLE**—A coil of cable whose inner end is attached to a member that rotates in relation to a member to which the outer end of the cable is fastened.

**ROUND CONDUCTOR FLAT CABLE**—A cable made with parallel round conductors in the same plane.

**ROUND WIRE SHIELDS**—Shields constructed from bare, tinned or silver-plated copper wire that include braided, spiral and reverse spiral.

**ROUTINE TESTS**—Tests made on each high-voltage cable or upon a representative number of devices, or parts, during production for the purposes of quality control.

**RS-232**—An ANSI/TIA recommended standard (RS); a common standard for connecting data processing devices. RS-232 defines the electrical characteristics of the signals in the cable that connect DTE (data terminal equipment) with DCE (data communications equipment); it specifies a 25-pin connector (the DB-25 connector is almost universally used in RS-232 applications). It is similar to ITU-T V.24/V.28.

**RS-232-C SERIAL I/O PORT**—A standard connection interface for computer peripheral equipment.

**RS-422**—An ANSI/TIA standard for cable lengths that exceed the RS-232 50-foot limit. Although introduced as a companion standard with RS-449, RS-422 is most frequently implemented on unused pins of DB-25 (RS-232) connectors. Similar to ITU-T V.11.

**RS-423**—An ANSI/TIA standard for cable lengths that exceed the RS-232 50-foot limit. Although introduced as a companion standard with RS-422, RS-423 is not widely used. Similar to ITU-T V.10.

**RTD**—Resistance temperature sensing device. Converts temperature to an electrical signal.

**RTS**—Request-to-send. An RS-232 modem interface signal (sent from the DTE to the modem on pin 4) that indicates that the DTE has data to transmit.

**RUBBER, ETHYLENE PROPYLENE (EPR)**—A synthetic rubber insulation having excellent electrical properties.



**RUBBER INSULATION**—A general term used to describe wire insulations made of elastomers such as natural or synthetic rubbers, neoprene, CSPE, EPR, CPE and others.

**RUS**—Rural Utilities Service. A federal agency formerly known as the REA.

## S

**S**—A UL cable type. Hard service flexible cord with thermoset insulation and jacket. Also see SO and SJ.

**SAE**—Society of Automotive Engineers. Automotive standards body.

**S BAND**—A band of frequencies between 1,550 and 5,200 megahertz.

**SBR**—A copolymer of styrene and butadiene. Also GRS or Buna-S.

**SCHERING BRIDGE**—See BRIDGE.

**SDN**—A small diameter multiconductor control cable with neoprene jacket and nylon sheath over polyethylene insulation.

**SECONDARY INSULATION**—A nonconductive material that protects the conductor against abrasion and provides a second barrier.

**SEGMENTAL CONDUCTOR**—A stranded conductor consisting of three or more stranded conducting elements, each element having approximately the shape of the sector of a circle, assembled to give a substantially circular cross section.

**SELF-EXTINGUISHING**—Characteristic of a material whose flame is extinguished after the igniting flame source is removed.

**SEMICONDUCTOR**—In wire industry terminology, a material possessing electrical conduction properties that fall somewhere between conductors and insulators. Usually made by adding carbon particles to an insulator and used to provide a graduated transition between conductor and insulation in high-voltage cable. Not the same as semiconductor materials, such as silicon, germanium, etc., used for making transistors and diodes.

**SEMICONDUCTING JACKET**—A jacket having a sufficiently low-electrical resistance so its outer surface can be kept at substantially ground potential.

**SEMIRIGID CABLE**—Generally refers to Type MI or Type ALS that can be bent or shaped into a required configuration from coils or reels.

**SEMIRIGID PVC**—A hard semiflexible polyvinylchloride compound with low plasticizer content.

**SEMISOLID**—An insulation cross-section having a partially open space between the conductor and the insulation perimeter.

**SENSITIVE CONDUCTOR**—A conductor terminated to a circuit that is adversely affected by spurious signals.

**SEPARABLE INSULATED CONNECTOR**—An insulated device to facilitate cable connections and separations.

**SEPARATOR**—Pertaining to wire and cable, a layer of insulating material such as textile, paper, Mylar, etc., which is placed between a conductor and its dielectric, between a cable jacket and the components it covers, or between various components of a multiple-conductor cable. It can be used to improve stripping qualities and/or flexibility, or can offer additional mechanical or electrical protection to the components it separates.

**SE-R**—Style R residential service entrance cable.

**SERIAL INTERFACE**—An interface that requires serial transmission, or the transfer of information in which the bits composing a character are sent sequentially. Implies only a single transmission channel.

**SERIES CIRCUIT**—A circuit in which the components are arranged end to end to form a single path for current.

**SERVE**—A filament or group of filaments such as fibers or wires, wound around a central core.

**SERVED WIRE ARMOR**—Spiral wrap of soft galvanized steel wires wrapped around a cable to afford mechanical protection and increase the cable-pulling tension characteristic.

**SERVING**—A wrapping applied over the core of a cable or over a wire.

**SE**—A UL cable type. Service entrance cable, 600 volts.

**SEW, SEWF**—A CSA cable type. Silicone rubber-insulated equipment wire.

**SF**—A CSA cable type. Silicone rubber insulated fixture wire, solid or seven-strand conductor, 200°C.

**SFF**—A CSA cable type. Same as SF, except flexible stranding 150°C.

**SG**—A CSA cable type. Same as SW except with ground wires.

**SGO**—A CSA cable type. Same as SW0 except with ground wires.

**SHD**—Portable mine power cable, three or four individually shielded conductors, with grounding conductors, 5 kV through 25 kV.

**SHEATH**—The outer covering or jacket over the insulated conductors to provide mechanical protection for the conductors.

**SHIELD**—A sheet, screen or braid of metal, usually copper, aluminum or other conducting material placed around or between electric circuits or cables or their components, to contain any unwanted radiation, or to keep out any unwanted interference.

**SHIELD COVERAGE**—See SHIELD PERCENTAGE.

**SHIELDED INSULATED SPLICE**—An insulated splice in which a conducting material is employed over the full length of the insulation for electric stress control.

**SHIELDED LINE**—A transmission line whose elements confine radio waves to an essentially finite space inside a tubular conducting surface called the sheath, thus preventing the line from radiating radio waves.

**SHIELD EFFECTIVENESS**—The relative ability of a shield to screen out undesirable radiation. Frequently confused incorrectly with the term shield percentage, they are not the same.



**SHIELDING, POWER CABLE**—A conducting layer applied to increase safety, control dielectric stresses and prevent partial discharges.

**SHIELD PERCENTAGE**—The physical area of a circuit or cable actually covered by shielding material, expressed as a percentage.

**SHORT**—A low-resistance path that results in excessive current flow and often in damage.

**SHOVEL CABLE**—Normally an SHD-GC type that supplies high-voltage (2 kV to 25 kV) power to mobile equipment.

**SHRINKING RATIO**—The ratio between the expanded diameter and recovered diameter of shrinkable products.

**SHRINK TEMPERATURE**—The temperature that effects complete recovery of a heat shrinkable product from the expanded state.

**SHRINK TUBING**—Tubing that has been extruded, cross-linked and mechanically expanded, which when reheated or released will return to its original diameter.

**SHUNT**—A very low-resistance component used to divert a portion of the electric current.

**SHUNT WIRE**—A conductor joining two parts of an electric circuit to divert part of the current.

**SI**—An international system of standardized units of measurement.

**SIC (SPECIFIC INDUCTIVE CAPACITANCE)**—See DIELECTRIC CONSTANT.

**SIGNAL**—Any visible or audio indication that can convey information. Also, the information conveyed through a communications system.

**SIGNAL CABLE**—A cable designed to carry current of usually less than one ampere per conductor.

**SIGNAL-TO-NOISE RATIO**—A ratio of the amplitude in a desired signal to the amplitude of noise, usually expressed in dB.

**SILICONE**—A material made from silicon and oxygen. Can be in thermosetting elastomer or liquid form. The thermosetting elastomer form is noted for high heat resistance.

**SINGLE CABLE**—A one-cable system in broadband LANs in which a portion of the bandwidth is allocated for send signals and a portion for receive signals, with a guard band in between to provide isolation from interference.

**SINGLE-MODE**—Optical fiber in which only one mode of light can propagate.

**SINTERING**—Fusion of an extruded paste or a spirally applied tape wrap insulation or jacket by the use of high heat to a homogenous continuum. Usually employed for fluorocarbon, nonextrudable materials.

**SIS**—Switchboard wiring made with cross-linked polyethylene insulation.

**SJ**—A UL or CSA cable type. Junior hard service, rubber-insulated pendant or portable cord. Same construction as type S, but 300 V.

**SJO**—Same as SJ, but with oil-resistant jacket.

**SJ00**—Same as SJO but with oil-resistant insulation as well as an oil-resistant jacket.

**SJT**—A UL or CSA cable type. Junior hard service thermoplastic or rubber insulated conductors with overall thermoplastic jacket. 300 V.

**SJTO**—Same as SJT but oil-resistant thermoplastic outer jacket.

**SJTOO**—Same as SJTO but with oil-resistant insulation.

**SKIN EFFECT**—The tendency of alternating current, as its frequency increases, to travel only on the surface of a conductor.

**S METER**—An instrument to measure signal strength.

**S/N**—See SIGNAL-TO-NOISE RATIO.

**SNM**—Shielded nonmetallic sheathed cable.

**SO**—A UL or CSA cable type. Hard service cord, same construction as type S except oil-resistant thermoset jacket, 600 V.

**SOFT WIRE**—Wire that has been drawn or rolled to final size and then heated (annealed) to remove the effects of cold working.

**SOLEF**—Solvay's trademark for its PVDF polymer.

**SOLID CONDUCTOR**—A conductor consisting of a single wire.

**SOO**—Same as SO but with oil-resistant insulation.

**SOOW**—A UL or CSA cable type. Portable cord and control cable. 600 V. Same as SOO but UL Listed or CSA Certified for outdoor use.

**SOURCE COUPLING LOSS**—Loss of light intensity as the light from a source passes into an optical fiber.

**SPACER CABLE**—A type of overhead power distribution cable. Spacing is accomplished by ceramic or plastic hangers suspended from a support messenger.

**SPAN**—In flat conductors, distance between the reference edge of the first and the last conductor. In round conductors, distance between centers of the first and last conductors.

**SPC**—Statistical process control.

**SPECIFIC INDUCTIVE CAPACITY (SIC)**—Dielectric constant of an insulating material.

**SPIRAL SHIELD**—A metallic shield of fine stranded wires applied spirally rather than braided.

**SPIRAL STRIPE**—A color coding stripe applied helically to the surface of an insulated wire or cable.

**SPIRAL WRAP**—The helical wrap of a tape or thread over a core.

**SPLICE**—A connection of two or more conductors or cables to provide good mechanical strength as well as good electrical conductivity.

**SPLITTER**—A passive device used in a cable system to divide the power of a single input into two or more outputs of lesser power. Can also be used as a combiner when two or more inputs are combined into a single output.

**SP-1**—A UL cable type. All thermoset, parallel-jacketed, two-conductor light duty cord for pendant or portable use in damp locations, 300 V.

**SP-2**—Same as SP-1, but heavier construction, with or without a third conductor for grounding purposes, 300 V.

**SP-3**—Same as SP-2, but heavier construction for refrigerators or room air conditioners, 300 V.

**SPT**—A UL type of thermoplastic-insulated, two- or three-conductor parallel cord. Frequently called “zip cord” or “lamp cord.”

**SQUIRREL CAGE MOTOR**—An induction motor having the primary winding (usually the stator) connected to the power and a current is induced in the secondary cage winding (usually the rotor).

**SR**—Silicone rubber cable 600 V, 125°C.

**SRG**—A cable with ozone-resistant silicone rubber insulation with an overall jacket of braided glass yarn impregnated with flame-, heat- and moisture-resistant finish. 150/200°C 600 V appliance and motor lead wire.

**SRGK**—A cable with ozone-resistant silicone rubber insulation with braided glass yarn conductor jacket. Cable core of insulated conductors shielded or unshielded and an overall jacket of braided K-fiber impregnated with flame-, heat- and moisture-resistant finish. 150/200°C 600 V multiconductor cable.

**SRK**—A cable with ozone-resistant silicone rubber insulation with an overall jacket of braided K-fiber impregnated with flame-, heat- and moisture-resistant finish. 200°C 600 V fixture wire and power cable.

**ST**—A UL cable type. Hard service cord, jacketed, same as type S except thermoplastic construction. 600 V, 60°C to 105°C.

**ST1**—Smoke Test #1. An optional rating for UL Listed cable types that also pass the Limited Smoke requirements contained in UL Standards. A cable that meets the requirement can be marked “ST1.”

**STABILITY FACTOR**—The difference between the percentage power factor at 80 volts/mil and at 40 volts/mil measured on wire immersed in water at 75°C for a specified time.

**STANDARD**—A set of rules or protocols that describe how a device should be manufactured so it will be reliable and interoperable (compatible) with others of the same type from different manufacturers.

**STANDING WAVE**—The stationary pattern of waves produced by two waves of the same frequency traveling in opposite directions on the same transmission line. The existence of voltage and current maximum and minimum along a transmission line is a result of reflected energy from an impedance mismatch.

**STANDING WAVE RATIO (SWR)**—In a transmission line, waveguide or analogous system, a figure of merit used to express the efficiency of the system in transmitting power.

**STATIC CHARGE**—An electrical charge that is bound to an object. An unmoving electrical charge.

**STAY CORD**—A component of a cable, usually a high-tensile textile, used to anchor the cable ends at their points of termination and to keep any pull on the cable from being transferred to the electrical connections.

**STEP INDEX FIBER**—A multimode optical fiber consisting of a core of uniform refractive index, surrounded by cladding of slightly lower refractive index.

**STIFFNESS**—As applied to copper, the property of a conductor that causes it to resist permanent deformation by bending.

**STO**—A North American flexible cord type. Same as ST but with an oil-resistant thermoplastic outer jacket, 600 V, 60°C.

**STOO**—Same as STO but with oil-resistant insulation.

**STOOW**—Same as STOO but suitable for use in wet locations.

**STOP JOINT**—A splice that is designed to prevent any transfer of dielectric fluid between the cables being joined.

**STP**—Shielded twisted pair. Two wires, wound around each other to help cancel out any induced noise in balanced circuits. Multiple pairs of wires are contained in one sheath and each wire pair is shielded.

**STRAIGHT JOINT**—A cable splice used for connecting two lengths of cable, each of which consists of one or more conductors.

**STRAIN GAUGE**—A device for determining the amount of strain (change in dimension) when a stress is applied.

**STRAIN HARDENING**—An increase in hardness and strength caused by plastic deformation at temperatures lower than the recrystallization range.

**STRAND**—One of the wires of any stranded conductor.

**STRANDED CONDUCTOR**—A conductor composed of a group of wires, usually twisted, or of any combination of such groups of wires.

**STRAND LAY**—The distance of advance of one strand of a spirally stranded conductor, in one turn, measured longitudinally. Also referred to as lay length.

**STRESS-RELIEF CABLE**—Cable used to relieve stresses in the process of welding pipe joints by inducing heat in pipe sections to be welded, flexible copper strand.

**STRESS-RELIEF CONE (TERMINATION)**—A device used to relieve the electrical stress at a shielded cable termination; generally used above 2,400 volts.

**STRIP**—To remove insulation from a wire or cable.

**STRUCTURAL RETURN LOSS**—Backward reflected energies from uneven parts of the cable structure.

**SUBSTRATE**—Insulating material layer on a printed wiring board.

**SUGGESTED WORKING VOLTAGE**—AC voltage that can be applied between adjacent conductors.

**SUPERCONDUCTORS**—Materials whose resistance and magnetic permeability are virtually zero at very low temperatures.

**SUPPRESSOR**—A device used to reduce or eliminate unwanted voltages in electric or electronic circuits. For example, a resistance conductor in, or a resistor in series with, a spark plug cable to suppress interference that would otherwise affect radio reception in and near the vehicle.

**SURFACE RESISTIVITY**—The resistance of a material between two opposite sides of a unit square of its surface. It is usually expressed in ohms.

**SURGE**—A temporary and relatively large increase in the voltage or current in an electric circuit or cable. Also called transient. Commonly caused by environmental conditions (lightning) or sudden load changes. Protective devices are employed to prevent damage from surges.

**SV**—A North American cable type. Vacuum cleaner cord, two or three conductor, rubber insulated. Overall rubber jacket. For light duty in damp locations, 300 V 60°C.

**SVO**—A North American cable type. Same as SV except oil-resistant thermoset jacket, 300 V, 60°C or 90°C.

**SVT**—A North American cable type, Same as SV except thermoplastic jacket. 300 V, 60°C or 90°C.

**SVTO**—A North American cable type. Same as SVT, except with oil-resistant thermoplastic jacket, 60°C.

**SW**—A CSA cable type. Rubber jacketed power supply cable (8 AWG to 2 AWG) 600 V.

**SWR**—Standing wave ratio. The ratio of incoming to reflected energy in a cable system. See also VSWR.

**SWEEP TEST**—A test to check attenuation at a range of frequencies.

## T

**TAKE-UP**—The process of accumulating wire or cable onto a reel, bobbin or some other type of pack. Also, the device for pulling wire or cable through a piece of equipment or machine.

**TANK TEST**—A dielectric strength test in which the test sample is submerged in water and voltage is applied between the conductor and the water acting as ground.

**TAP**—(1) Baseband. The component of a connector that attaches a transceiver to a cable. (2) Broadband. Also called a directional tap or multitap. A passive device used to remove a portion of the signal power from the distribution line and deliver it onto the drop line.

**TAPED INSULATION**—Insulation of helically wound tapes applied over a conductor or over an assembled group of insulated conductors.

**TAPED SPLICE**—A joint with hand-applied tape insulation.

**TAPE WRAP**—A spirally applied tape over an insulated or uninsulated wire.

**TC**—A UL cable type. See Tray Cable, NEC Article 336.

**TCLP**—Toxicity characteristic leaching procedure. A test created by the EPA to determine whether an item can be safely discarded in an ordinary (nonhazardous) landfill.

**T CONNECTOR**—A cable adapter that attaches a PC with a network interface module to the network.

**TEAR STRENGTH**—The force required to initiate or continue a tear in a material under specified conditions.

**TEFLON**—Trademark of the DuPont Co. for FEP, PTFE and PFA polymers.

**TEMPERATURE RATING**—The maximum temperature at which an insulating material may be used in continuous operation without loss of its basic properties.

**TENSILE STRENGTH**—The maximum load per unit of original cross-sectional area that a conductor attains when tested in tension to rupture.

**TERMINALS**—Metal wire termination devices designed to handle one or more conductors, and to be attached to a board, bus or block with mechanical fasteners.

**TERMINATOR**—A resistive device used to terminate the end of cable or an unused tap into its characteristic impedance. The terminator prevents interference-causing signal reflections.

**TEST LEAD**—A flexible, insulated lead wire used for making tests, connecting instruments to a circuit temporarily, or for making temporary electrical connections.

**TEW**—CSA appliance wire type. Solid or stranded single conductor, plastic insulated, 105°C, 600 V.

**TEXTILE BRAID**—Any braid made from threads of cotton, silk or synthetic fibers.

**TF**—A UL cable type. Fixture wire, thermoplastic-covered solid or seven strands, 60°C.

**TFF**—One of three types of Teflon. Also known as PTFE (polytetrafluoroethylene).

**TFF**—Same as TF but flexible stranding, 60°C.

**TFN**—Same as TFF but with nylon outer jacket.

**TFN**—Same as TF but with nylon outer jacket.

**TG**—Flexible nickel or nickel-clad copper conductor, Teflon tape, glass braid, 200°C.

**TGGT**—PTFE Teflon tape insulation with an insulation covering of wrapped glass yarn and an overall sheath of braided glass yarn impregnated with a moisture, heat, flame and fraying resistant compound. 600 V, 250°C appliance wire.

**TGS**—Solid or flexible copper, nickel-clad iron or copper, or nickel conductor. Teflon tape, silicone glass braid, 600 V, 250°C.

**THERMAL AGING**—Exposure to a thermal condition or programmed series of conditions for predescribed periods of time.

**THERMOCOUPLE**—A device consisting of two dissimilar metals in physical contact, which when heated will develop an EMF output.

**THERMOCOUPLE ELEMENT**—A thermocouple designed to be used as part of an assembly, but without associated parts such as terminal block, connecting head or protecting tube.

**THERMOCOUPLE EXTENSION CABLE**—A cable comprised of one or more twisted thermocouple extension wires under a common sheath.

**THERMOCOUPLE EXTENSION WIRE**—A pair of wires of dissimilar alloys having EMF temperature characteristics complementing the thermocouple with which it is intended to be used, such that when properly connected allows the EMF to be accurately transmitted to the reference junction.

**THERMOCOUPLE LEAD WIRE**—An insulated pair of wires used from the thermocouple to a junction box.

**THERMOPLASTIC**—A material that softens when heated and becomes firm on cooling.

**THERMOSET**—A material that has been hardened or set by the application of heat or radiation, and which, once set, cannot be resoftened by heating. The application of heat or radiation is called "curing."

**THHN**—A UL cable type. 600 V, 90°C nylon-jacketed building wire for use in dry and damp locations.

**THREE-PHASE CURRENT**—Current delivered through three wires, with each wire serving as a return for the other two.

**THREE-PHASE THREE-WIRE SYSTEM**—An alternating current supply system comprising three conductors over which three-phase power is sent.

**THREE-QUARTER-HARD WIRE**—As applied to aluminum, wire that has been processed to produce a strength approximately midway between that of half-hard wire and that of hard-drawn wire.

**THREE-WIRE SYSTEM**—A DC or single-phase AC system comprising three conductors, one of which is maintained at a potential midway between the potential of the other two.

**THW**—A UL cable type. Thermoplastic vinyl-insulated building wire. Flame-retardant, moisture and heat resistant. 75°C rated in dry and wet locations.

**THW-2**—A UL cable type. Thermoplastic vinyl-insulated building wire. Flame-retardant, moisture and heat resistant. 90°C rated in dry and wet locations.

**THWN**—A UL cable type. Same as THW but with nylon jacket overall. Rated 75°C in wet and dry locations.

**THWN-2**—A UL cable type. Same as THW but with nylon jacket overall. Rated 90°C in wet and dry locations.

**TIA**—Telecommunications Industries Association.

**TINNED WIRE**—See COATED WIRE, OVERCOAT CONDUCTOR and TOPCOATED.

**TIN OVERCOAT (TOC)**—Tinned copper wire, stranded, then coated with tin.

**TINSEL WIRE**—A low-voltage stranded wire, with each strand a very thin conductor ribbon spirally wrapped around a textile yarn.

**TKGT**—PTFE Teflon tape insulation with an insulating covering of felted K-fiber yarn and an overall sheath of braided glass yarn impregnated with a moisture-, heat-, flame- and fraying-resistant compound. 250°C, 600 V apparatus and motor lead wire.

**TL-9000**—A quality system for the telecommunications industry based on ISO 9000.

**TNC**—A threaded connector for miniature coax; TNC is said to be an abbreviation for threaded-Neill-Concelman. Contrast with BNC, a similar nonthreaded bayonet connector.

**TOPCOATED**—Bare (untinned) copper wire, stranded then coated with pure tin.

**TPE**—Thermoplastic elastomer.

**TRACER**—A means of identifying an individual conductor (e.g., for polarity, etc.).

**TRANSCEIVER**—A device required in baseband networks which takes the digital signal from a computer or terminal and imposes it on the baseband medium.

**TRANSCEIVER CABLE**—Cable connecting the transceiver to the network interface controller allowing nodes to be placed away from the baseband medium.

**TRANSFER IMPEDANCE TEST**—A laboratory test that measures the effectiveness of a cable shield to keep EMI in (or out) of the cable. Usually conducted per NEMA WC61. Sometimes also referred to as a “surface transfer impedance” test.

**TRANSITION SPLICE**—A cable splice that connects two different types of cable.

**TRANSMISSION**—The dispatching of a signal, message, or other form of intelligence by wire, radio, telegraphy, telephony, facsimile, or other means.

**TRANSMISSION CABLE**—Two or more transmission lines. See TRANSMISSION LINE.

**TRANSMISSION LINE**—A signal-carrying circuit with controlled electrical characteristics used to transmit high-frequency or narrow-pulse signals.

**TRANSMISSION LOSS**—The decrease or loss in power during transmission of energy from one point to another. Usually expressed in decibels.

**TRANSPPOSITION**—Interchanging the relative positions of wires to neutralize the effects of induction to or from other circuits or to minimize interference pickup by the lead-in during reception.

**TRAY**—A cable tray system is an assembly of units or sections and ancillary fittings, made of noncombustible materials used to support cables. Cable tray systems include ladders, troughs, channels, solid bottom trays and similar structures.

**TRAY CABLE**—A factory-assembled multiconductor or multipair control cable approved under the National Electrical Code for installation in trays.

**TREEING**—Microscopic tree-like channels in medium-voltage cable insulation that can lead to cable failure.

**TRIAxIAL**—A three-conductor cable with one conductor in the center, a second circular conductor concentric with and insulated from the first, and a third circular conductor insulated from and concentric with the second, and an impervious sheath overall.

**TRIBOELECTRIC NOISE**—Noise generated in a shielded cable due to variations in capacitance between shielding and conductor as the cable is flexed.

**TROLLEY WIRE**—A round or shaped solid, bare, hard conductor ordinarily used to supply current to motors through traveling current collectors.

**TRUNK CABLE**—A main cable used for distribution of signals over long distances throughout a cable system.

**TRUE CONCENTRIC**—A cable conductor in which each successive strand layer has a reversed direction of lay from the preceding layer.

**TR-XLP**—Tree retardant cross-linked polyethylene.

**TUBING**—A tube of extruded unsupported plastic material.

**TURNKEY SYSTEM**—Refers to any system that is completely assembled and tested by one party for another that only requires the purchaser to turn the key on to be fully operational.

**TV CAMERA CABLE**—Multiconductor (often composite) cable to carry power for camera, lights, maneuvering motors, intercom signals to operators, video, etc. Usually heavy-duty jacketed.

**TW**—A UL wire type. Thermoplastic vinyl-jacketed building wire, moisture resistant and rated 60°C.

**TWINAXIAL CABLE**—A shielded coaxial cable with two central insulated conductors.

**TWIN COAXIAL**—A coaxial cable configuration containing two separate, complete coaxial cables laid parallel or twisted around each other in one unit.

**TWIN-LEAD**—A transmission line having two parallel conductors separated by insulating material. Line impedance is determined by the diameter and spacing of the conductors.

**TWINNER**—A device for twisting together two conductors.

**TWINNING**—Synonymous with pairing.

**TWISTED PAIR**—A pair of insulated copper conductors that are twisted around each other, mainly to cancel the effects of electrical noise; typical of telephone and LAN wiring.

## U

**U-BEND TEST**—A cable test in which the insulation is tested for resistance to corona and ozone.

**UF**—A UL Underground Feeder cable type. Thermoplastic underground feeder or branch circuit cable.

**UHF**—Ultrahigh frequency, the band extending from 300 to 3,000 MHz as designated by the Federal Communications Commission.

**UL**—Underwriters Laboratories, Inc. A U.S. independent testing laboratory that also publishes standards for most products in the NEC.

**UL LISTED**—A product that has been tested and found to comply with applicable standards. Listing also involves regular follow-up to ensure continued compliance.

**UL STYLE**—A subset of UL Type AWM (appliance wiring material) consisting of thousands of different styles. Many UL styles are single-conductor hook-up wire. A unique four or five digit number, e.g., UL 1015, identifies each style. Styles identify an additional subset of features from the referenced standards in order to allow customers to quickly identify the type of wire needed.

**ULTRASONIC CLEANING**—Immersion cleaning aided by ultrasonic waves that cause microagitation.

**ULTRASONIC DETECTOR**—A device that detects ultrasonic noise such as that produced by corona or leaking gas.

**ULTRAVIOLET**—Radiant energy within the wavelength range 10 to 380 nanometers. It is invisible and can be filtered out by glass.

**UNBALANCED LINE**—A transmission line in which voltages on the two conductors are unequal with respect to ground (e.g., coaxial cable).

**UNBALANCED-TO-GROUND**—Describing a two-wire circuit, where the impedance-to-ground on one wire is measurably different from that on the other, compare with BALANCED LINE.

**UNIDIRECTIONAL CONDUCTOR**—See CONCENTRIC-LAY CONDUCTOR.

**UNIDIRECTIONAL STRANDING**—A term denoting that in a stranded conductor all layers have the same direction of lay.

**UNILAY**—More than one layer of helically-laid wires with the direction of lay and length of lay the same for all layers. See CONCENTRIC-LAY CONDUCTOR.

**USE**—A UL cable type. Underground service entrance cable, XLP or rubber-insulated, CSPE or XLP jacketed.

**UTP**—Unshielded twisted pair. Two wires, usually twisted around each other to help cancel out induced noise in adjacent circuits. An unshielded twisted-pair cable usually contains four pairs in a single cable jacket.

## V

**V**—Volts. The SI unit of electrical potential difference. One volt is the difference in potential between two points of a conducting wire carrying a constant current of one ampere when the power dissipated between these two points is equal to one watt. It represents the energy available per unit charge within an electrical system (joules /coulombs).

**VA**—Volt-ampere. A designation of power in terms of volts and amperes. See APPARENT POWER.

**VAR**—A unit of reactive power that means volt-amperes, reactive.

**VAR METER**—An instrument used by power companies to measure the kVAR consumption. Utilities charge more for loads that consume large amount of reactive power.

**V BAND**—A band of frequencies between 46 and 56 gigahertz.

**VC**—Varnished-cambric insulation.

**VCSEL**—Vertical-cavity surface-emitting laser is a type of semiconductor laser diode operating in the 850-nm wavelength window that is commonly used in Ethernet-based networks.

**VDE**—Association of German Electrical Engineers.

**VELOCITY OF PROPAGATION**—The transmission speed of an electrical signal down a length of cable compared to its speed in free space. Usually expressed as a percentage.

**VFD CABLE**—Variable frequency drive cable. A power cable specially designed for use with VFDs. Usually has three-phase conductors, three symmetrically positioned grounding conductors and an overall RF shield. Also called adjustable speed drive (ASD) cable.

**VG**—Varnished-glass or nylon braid, 600 V or 3,000 V, 130°C.

**VHF**—Very high frequency. The band extending from 30 to 300 MHz as designated by the Federal Communications Commission.

**VIDEO PAIR CABLE**—A transmission cable containing low-loss pairs with an impedance of 125 ohms. Used for TV pickups, closed-circuit TV, telephone carrier circuits, etc.

**VISCOSITY**—Internal friction or resistance to flow of a liquid: the constant ratio of shearing stress to rate of shear.

**VLF**—Very low frequencies. The band extending from 10 to 30 kHz, as designated by the Federal Communications Commission.

**VOICE FREQUENCY (VF)**—Describes an analog signal within the range of transmitted speech, typically supported by an analog telecommunications circuit.

**VOLT**—A unit of electrical “pressure.” One volt is the amount of electrical potential that will cause one ampere of current to flow through one ohm of resistance. Volt is a SI unit, the base units are joules (energy) per coulomb (charge) (J/C).

**VOLTAGE**—Electrical potential or electromotive force expressed in volts.

**VOLTAGE BREAKDOWN**—A test to determine the maximum voltage insulated wire can withstand before failure.

**VOLTAGE, CORONA EXTINCTION**—The minimum voltage that sustains corona (partial discharge), determined by applying a corona producing voltage, then decreasing the voltage until corona is extinct.

**VOLTAGE DIVIDER**—A network consisting of impedance elements connected in series to which a voltage is applied and from which one or more voltages can be obtained across any portion of the network.

**VOLTAGE DROP**—The voltage developed across a conductor by the current and the resistance or impedance of the conductor. Also refers to the voltage used in a system to overcome the wiring resistance. Long runs of cable sized closely to the operating ampacity can suffer significant voltage drop that affects the load. Less than 5 percent is recommended by the NEC, around or less than 2 percent is ideal. Using larger conductor (less resistance) if possible will solve voltage drop problems.

**VOLTAGE, INDUCED**—A voltage produced in a conductor by a change in magnetic flux from an outside source.

**VOLTAGE RATING**—The highest voltage that may be continuously applied to a wire or cable in conformance with standards or specifications.

**VOLTAGE STANDING WAVE RATIO (VSWR)**—The ratio of the maximum effective voltage to the minimum effective voltage measured along the length of a mismatched radio frequency transmission line.

**VOLTAGE TO GROUND**—The voltage between an energized conductor and earth.

**VOLUME RESISTIVITY**—The resistance in ohms of a body of unit length and unit cross-sectional area.

**VSWR**—See VOLTAGE STANDING WAVE RATIO.

**VULCANIZATION**—A chemical reaction in which the physical properties of a polymer are changed by reacting it with cross-linking agents.

**VW-1**—Vertical wire flame test. Formerly designated as FR1. A UL fire rating for single conductor cables. The test is described in UL Standard 1581.

## W

**W**—(1) Symbol for watt or wattage. (2) A UL cable type. Heavy-duty portable power cable, one to six conductors. 600 V, without grounds.

**WALL THICKNESS**—The thickness of a applied insulation or jacket. Generally wall thickness increases for higher voltages.

**WATER ABSORPTION**—A test to determine the amount of water absorbed by a material after a given immersion period.

**WATER-BLOCKED CABLE**—A multiconductor cable having interstices filled with a water-blocking compound to prevent water flow or wicking.

**WATER-COOLED LEADS**—Furnace cables. High-energy cables. Usually welding cable strands cabled with a hose core for carrying coolant used in heavy-duty welding equipment, electric furnace applications, plating and various chemical processes.

**WATER TREEING**—A type of insulation deterioration that can occur after long-term immersion in water with an electrical stress applied.

**WATERFALL**—The point at which cables installed horizontally in a tray transition to a vertical section of tray.

**WATT**—A unit of electrical power (energy consumed per unit time). One watt is equivalent to the power represented by one ampere of current under a pressure of one volt in a DC circuit.

**WAVEFORM**—A graphical representation of a varying quantity. Usually, time is represented on the horizontal axis and the current or voltage value is represented on the vertical axis.

**WAVE FRONT**—(1) That portion of an impulse (in time or distance) between the 10 percent point and the point at which the impulse reaches 90 percent of crest value. (2) The rising part of an impulse wave.

**WAVELENGTH**—The distance between the nodes of a wave. The ratio of the velocity of the wave to the frequency of the wave.

**WAVESHAPE REPRESENTATION**—The designation of current or voltage by a combination of two numbers. For other than rectangular impulses: (a) virtual duration of the wave front in microseconds; and (b) time in microseconds from virtual zero to the instant at which one-half of the crest value is reached on the tail. For rectangular impulses: (a) minimum value of current or voltage; and (b) duration in microseconds.

**WEEE**—Waste Electrical and Electronic Equipment. A European Union regulation (Directive 2002/96/EC) which holds the manufacturer responsible for proper recycling or disposal when it reaches end-of-life. See also RoHS and REACH.

**WEIGHT RESISTIVITY**—The resistance in ohms at a specified temperature of a copper wire of uniform cross section and of unit weight and unit length.

**WELDING**—Joining the ends of two wires, rods or groups of wires: (a) by fusing, using the application of heat or pressure or both, by means of a flame torch, electric arc, or electric current; or (b) by cold pressure.

**WHEATSTONE BRIDGE**—A device used to measure DC resistance. See BRIDGE.

**WICKING**—The longitudinal flow of a liquid in a wire or cable due to capillary action.

**WIRE**—A rod or filament of drawn or rolled metal whose length is great in comparison with the major axis of its cross section.

**WIRE BRAID**—Flexible wire constructed of small size strands in tubular form. Used for shielding or connections where constant flexing is required.

**WIRE GAUGE (AWG)**—The American Wire Gauge, originally called Brown & Sharpe Gauge. A system of numerical wire sizes starting with the lowest numbers for the largest sizes. Gauge sizes are each 20.6 percent apart based on the cross-sectional area.

**WIRE NUT**—A closed-end splice that is screwed on instead of crimped.

**WIRE-WRAPPED CONNECTION**—A solderless connection made by wrapping bare wire around a square or rectangular terminal with a power or hand tool.

**WIRE WRAPPING TOOLS**—Portable electric tools and automatic stationary machines used to make solderless wrapped connections of wires to terminals.

**WITHSTAND TEST VOLTAGE**—The voltage that the device must withstand without flashover, disruptive discharge, puncture or other electric failure when voltage is applied under specified conditions.

**WP**—Weatherproof construction for overhead wires.

**WORKSTATION**—(1) Input/output equipment at which an operator works;  
(2) A station at which a user can send data to, or receive data from, a computer or other workstation for the purpose of performing a job.

**WRAPPER**—An insulating barrier applied as a sheet of tape wrapped around a coil periphery.

## X

**X**—Symbol for reactance.

**X BAND**—A band of frequencies between 5,200 and 10,000 megahertz.

**XHHW**—A UL cable type. Cross-linked polyethylene insulated small diameter building wire rated 75°C wet and 90°C dry.

**XHHW-2**—A UL cable type. Cross-linked polyethylene insulated small diameter building wire rated 90°C wet and dry.

**XLP**—Cross-linked polyethylene. Also written XLPE.

## Y

**YIELD STRENGTH**—The point at which a substance changes from elastic to viscous.

## Z

**Z**—Symbol for impedance.

**ZERO SEQUENCE IMPEDANCE**—The electrical impedance of a three-phase power cable under fault (short-circuit) conditions. It is typically 2.5 to 3 times the positive sequence impedance.

**ZETABON**—Dow's trade name for an acrylic acid copolymer coated aluminum tape.

**ZIPPER TUBING**—Alpha's trade name for harnessing/jacketing material containing a zipper-track type closure. The zipper arrangement allows installation with no need to disconnect installed wire. See LOC-TRAC.

**ZYTEL**—DuPont's trademark for nylon resins.





# GENERAL INDEX

## Symbols

2-Pole, 2-Wire	145
2-Pole, 3-Wire	145
3 meter cube smoke apparatus	168
3-Pole, 3-Wire, 3-Phase	145
3-Pole, 4-Wire	145
4 GHz connectors	131
4-Pole, 4-Wire	147
4-Pole, 5-Wire	147
4-Wire, 3-Phase	145
15 kV power cable	72
50-ohm connectors	131
100-ohm Unshielded Twisted Pair (UTP) vs Shielded Twisted Pair	78
35,000 Volts	183
210,000 Btu flame test	179
400 and 800 Hz ampacity factors	100
600 V control cable	68
8000 Series aluminum alloy wire	163
<b>A</b>	
AAR	161
ABNT	221, 224
Abrasion resistance	47
AC90	228
Accelerated aging test for MV power cables	169
Acceptance cone	82
Acceptance testing	122
AC/DC resistance ratio at 60 Hz	93
ACIC	231
Acid resistance	47
ACMA	236
AC resistance	93
of Class B aluminum conductors	91
of Class B copper conductors	89
ACRF	77
ACWU90	229
AEE	190
AEIC	161
AENOR	208
Aerial cable messengers	120
Aerial Service Wire(s)	165, 172
Aerospace Vehicle Wiring	172
AFNOR	200
Aircore cable	78
Airframe wire	80
Airport	
lighting	166, 175
series lighting cables	226
Alcohol resistance	47
Alkali resistance	47
Allowable Fill	110
Alumel	II, 69
Aluminum	
1350 solid round wire	22
clad steel	119
compression connectors	134
Conductors, Coated-Steel Reinforced (ACSR)	24
strand properties	22
wire	6
American National Standards Institute	162
American Society for Testing and Materials (ASTM)	II, 162
American Wire Gauge	6
Ampacities	166
at 400 and 800 Hz	166
for Conductors Rated 0–2,000 Volts	183
including effect of shield losses	171
including shield losses for 15 through 69 kV cables	102
of cables in open-top cable trays	102
of Cables Installed in Cable Trays	171
of Conductors Rated 2001 to 35,000 Volts	183

**Ampacities at 400 and 800 Hz** ..... 166

**Ampacity** ..... 2, 100, 102

derating of fire-protected cables ..... 169

power cables ..... 102

tables ..... 102

**Ampere** ..... 2

**Amperes**

when horsepower is known ..... 252

when kilovolt-amperes are known ..... 252

when kilowatts are known ..... 252

**Anaerobic** ..... 140

**ANCE** ..... 221, 222

**Angle of burner** ..... 177

**Annular conductor** ..... 8

**ANSI** ..... 162

**Appliance Wiring Material** ..... 174

**Arbor hole** ..... 156

diameter ..... 150

**Argentine standards** ..... 224

**Armor** ..... 62

**Armored cable(s)** ..... 73, 173

power and control ..... 73

**AS/ACIF S009** ..... 236

**Asia Pacific** ..... 235

**AS/NZS 3000** ..... 236

**Asociación de Normalización y Certificación** ..... 222

**Asociación Española de Normalización y Certificación** ..... 208

**Associação Brasileira De Normas Técnicas** ..... 224

**Association Française de Normalisation** ..... 200

**Association of American Railroads** ..... 161

**Association of Edison Illuminating Companies** ..... 161

**ASTM** ..... 162

D2863 ..... 52

**Attenuation** ..... 79, 82, 127

at high frequencies ..... 10

change at low temperatures ..... 83

of the fiber ..... 127

**Australian**

Communications and Media Authority ..... 236

Plug Configuration ..... 237

Standards ..... 236

**Austrian**

Plug Configuration ..... 197

Standards ..... 197

**Authority having jurisdiction** ..... 183

**Automobile Truck, Truck-Tractor, Trailer, and Motor Coach Wiring** ..... 172

**AWM** ..... 174, 182

**B**

**Balanced mode** ..... 75

**Bandmarking** ..... 46

**Bandwidth** ..... 81

at a specified wavelength ..... 82

**BASEC** ..... 190, 216

**Basic Impulse Level (BIL) Ratings** ..... 102

**Basic principles of electricity** ..... 1

**Basket-weave**

armor ..... 63

pulling grip ..... 111

**Bayonet** ..... 131

coupling ..... 131

**BBC** ..... 216

**Belden electronic color code** ..... 43

**Belgian**

plug configurations ..... 198

standards ..... 198

**Bellcore** ..... 164

**Bending radii for cables without metallic shielding** ..... 115

**Bending radius** ..... 115

for all single conductor cables with metallic shielding ..... 115

for fiber optic cable ..... 115

for portable cables ..... 115

for Type MC cable ..... 115

**Bend multipliers** ..... 114

for pulling tension calculations ..... 114

**Benzol, toluol, etc. resistance** ..... 47

**BIL ratings** ..... 102

**Binder tape** ..... 72

**BNC connector** ..... 131

**BNFL** ..... 216

**Boat cable** ..... 182

**Braid shield** ..... 59

**Brake system cable** ..... 161

**Brazilian standards** ..... 224

**BRB** ..... 216

**Breaking load** ..... 10

**Breaking strength** ..... 12

**Breakout kit** ..... 141

**Bridle wire** ..... 165

<b>British</b>	
Approvals Service for Cables	216
Broadcasting Company	216
Defense Standards	218
Nuclear Fuels	216
Railways Board	216
standards	214
Telecom	216
thermal units	247
<b>BSI</b>	214
<b>BT Group</b>	216
<b>Buffer tube fanout</b>	141
<b>Building Code of Canada</b>	232
<b>Building Wire</b>	68
<b>Bunch-stranded copper conductors</b>	162
<b>Bunch stranding</b>	7, 11, 20
<b>Bureau de Normalisation</b>	198
<b>Buried distribution</b>	78
	<b>C</b>
<b>C22.1</b>	226
<b>C22.2 No. 0</b>	226
<b>C22.2 No. 131</b>	226
<b>Cable</b>	
accessories	129
Connectors for Audio Facilities for Radio Broadcasting	165
feed-in setups	116
for LAN twisted pair data communications	165
for locomotive and car equipment	161
for power circuits with rubber insulation rated to 450/750 V	203
for power circuits with thermoplastic insulation rated to 450/750 V	203
grips	111
identification code	191
length measurement	127
pulling guide	161
termination	123
tray installation	144
trays	166, 183
tray systems	143
types and selection criteria	65
<b>Cables</b>	
for boats	174
for Non-Power-Limited Fire-Alarm Circuits	174
for Power-Limited Fire-Alarm Circuits	174
<b>Cabling for data center premises</b>	167
<b>Cadmium</b>	6
<b>Canada</b>	226
<b>Canadian</b>	
Electrical Code	232
Electrical Code, Part I	226
FT4 test	179
plug configurations	231
Standards Association (CSA)	II, 226
<b>CANENA</b>	165
<b>Capacitance</b>	78, 253, 256
<b>Capacities and dimensions of shipping reels</b>	152
<b>Categories 3, 5e, 6 and 6A</b>	76
<b>Category</b>	
3, 4, 5 or 6	127
3 UTP performance	76
5e UTP performance	76
6 and Category 7 100 ohm shielded and unshielded twisted pair cables	171
6A UTP performance	77
6 UTP performance	77
<b>CCW armor</b>	62
<b>CEBEC</b>	
(Comite Electrotechnique Belge Service de la Marque)185, 190, 198	
<b>CEI</b>	205
<b>Cellular</b>	
polyethylene	47, 48
<b>CEN</b>	196
<b>GENELEC</b>	
cable identification	191
color codes	193
copper conductors	193
(European Committee for Electrotechnical Standards) . . .	185, 189
harmonized approvals	190
<b>Central office</b>	
cable	164
coaxial cable	164
hook-up wire	165
<b>Centro Elettrotecnico Sperimentale Italiano</b>	205
<b>CESI</b>	205
<b>Channel cable tray</b>	144
<b>Characteristic impedance</b>	79
of a coaxial cable	74
<b>Charging current</b>	122
<b>Char length</b>	177

<b>Chinese</b>	
National Institute of Standardization	240
Quality Certification Center	240
standards	240
<b>Chlorinated Polyethylene</b>	
(CPE)	34
<b>Chlorosulfonated polyethylene</b>	37
jackets for wire and cable	164
<b>Chromel</b>	II
vs alumel	69
vs constantan	69
<b>CI</b>	
Circuit Integrity	84
<b>CIC</b>	231
<b>CIGRE</b>	200
<b>Circular measurements</b>	
diameter, circumference and area	244
<b>Circular mil(s)</b>	6, 246
<b>Circulating currents</b>	233
<b>Circumscribing circle</b>	255
<b>CL2</b>	84, 182
<b>CL3</b>	84, 182
<b>Cladding</b>	81
<b>Class</b>	
1E electric cables, field splices and connections for nuclear power generating stations	169
2	31, 191
5	191
6	191
AA	11
B	9
B aluminum	23
B, C and D compact and compressed copper	14
B, C, D, compact and compressed diameters	16
B concentric-lay-stranded compressed, reverse-lay aluminum 1350 conductors	23
B concentric-lay-stranded copper conductors	14
H copper	17
I (24 AWG strands) rope-lay-stranded copper conductors	19
K (30 AWG strands) rope-lay-stranded copper conductors	20
M (34 AWG strands) rope-lay-stranded copper conductors	21
<b>Class H</b>	
rope-lay-stranded	17
rope-lay-stranded copper conductors	17
<b>Clearance between conduit and cable</b>	112
<b>CM</b>	84, 182
<b>CMP</b>	84
<b>CMR</b>	84
<b>CMX</b>	79
<b>CNIS</b>	240
<b>Coatings</b>	10
<b>Coax Connectors</b>	
for Flexible Cable	132
for Semirigid Cable	132
<b>Coaxial</b>	
cable	59, 73
capacitance	256
connectors	131
connectors for CATV 75	165
distribution cable	164
drop cable	164
transmission lines	173
transmission lines and connectors	173
types	74
<b>Coefficient of friction</b>	114
<b>Colombian</b>	
National Electrical Standard	224
standards	224
<b>Color</b>	
identification and coding	166
<b>Color chart for insulation and sheath of electric cables</b>	214
<b>Color code</b>	
for flexible cables	193
for thermocouple extension wire	70
for thermocouple wire	70
<b>Color coding</b>	38
<b>Colors of the cores of flexible cables and cords</b>	167
<b>Comitato Elettrotecnico Italiano</b>	205
<b>Comité Electrotechnique Belge</b>	198
<b>Common conductor materials</b>	6
<b>Communication</b>	
cables	173
cables for outdoor use	166
Circuits	184
<b>Compact</b>	
conductor	8
strand	8
<b>Comparison of vertical cable tray tests</b>	177
<b>Composite tips</b>	140

<b>Compressed</b>	
conductors	8
connector	134
strand	8
<b>Compression</b>	
connector	134
terminals	135
tools	135
<b>Concentric</b>	8
lay	11
Neutral Cables Rated 5 through 46 kV	167
Neutral Power Cable Rated 5-45 kV	227
strand	7
stranded conductor	8
stranded conductor diameter from wire diameter	256
<b>Concentric-lay-stranded</b>	
Aluminum 1350 Conductors	24, 162
Aluminum Conductors, Coated-Steel Reinforced (ACSR)	24, 162
Conductors of 8000 Series Aluminum Alloy	163
<b>Conductive shield</b>	56
<b>Conductor(s)</b>	6
area	242
characteristics	6
diameter from wire diameter	256
of insulated cables	167, 189, 215
properties	26
resistance (ohm per loop-mile)	79
resistances	166
shield (strand shield)	56
short circuit current	96
short circuit current for aluminum cables	98
short circuit current for copper cables	97
size conversion	242
<b>Conduit</b>	
fill	106, 112, 184
size	110
<b>Conference International des Grands Reseaux Electriques a Haute Tension</b>	200
<b>Connector(s)</b>	134, 137
termination methods	141
tips made from ceramic	140
<b>Constants</b>	251
<b>Construction and building wire</b>	68
<b>Continental Europe</b>	187
<b>Continuously Corrugated and Welded (CCW)</b>	62
<b>Control</b>	
and instrumentation cables	227
cables	68, 167, 171
instrumentation and thermocouple	68
<b>Conversion</b>	
factors	246
tables	242, 244, 246, 248, 249
<b>Conveyor sheave(s)</b>	113, 118
<b>Copper</b>	
annealed	6
braid construction	59
braid shield	59
compression connectors	134
conductor stranding, diameter, area, weight and DC resistance	28
DC resistance	26
drain wire	58
hard drawn	6
shielding tape	72
strand properties	11
tape shields	57
vs constantan	70
wire shield	72
<b>Copper-clad steel</b>	119
<b>Copperweld</b>	III
<b>Core</b>	82
diameter	82
<b>Corona</b>	123
<b>Corrosion resistance</b>	10
<b>Corrosivity</b>	176
<b>Corrugated copper wires</b>	57
<b>Council for the Harmonization of Electrical Standards of the Americas</b>	165
<b>CP</b>	36
<b>CPE</b>	34, 48
<b>CQC</b>	240
<b>Creepage surface</b>	123
<b>Cross-connect and breakout applications</b>	137
<b>Cross-linked polyethylene</b>	
insulation for wire and cable rated 0 to 2,000 V	163
insulation for wire and cable rated 2,001 V to 35 kV	163
(XLP or XLPE)	36, 51
<b>Crosstalk</b>	78, 79, 127
<b>Crosstalk, attenuation, impedance</b>	127
<b>CSA</b>	II, 226
FT1	176
FT4	176, 177, 179, 180
FT6	176, 178

**CSA cable types** ..... 228  
**CSP** ..... 37  
**Current-carrying capacity**  
 (ampacity) ..... 71  
**Current loading**  
 (ampacity) ..... 71  
**Current rating**  
 of cables (100% load factor) ..... 168  
**Current ratings**  
 for electronic cables ..... 101  
 for power applications ..... 101

**D**

**Danish**  
 plug configuration ..... 199  
 standards ..... 199  
**Danmarks Elektriske Materielkontrol** ..... 199  
**Data**  
 centers ..... 173  
 connectors ..... 133  
 grade media (DGM) ..... 78  
**Data-processing cable** ..... 174  
**DC**  
 field test voltages ..... 124  
 hipot testing ..... 122  
 hipot test voltages ..... 124  
 maintenance testing ..... 123  
 resistance ..... 26, 193, 194, 195, 196  
 resistance and stranding of Class 2 copper conductors ..... 194  
 resistance and stranding of Class 5 (flexible)  
 copper conductors ..... 195  
 resistance and stranding of Class 6 (Highly Flexible)  
 copper conductors ..... 196  
 resistance of Class 1 (Solid) copper conductors ..... 193  
 resistance of plated copper conductors ..... 86  
 resistance ohms/1,000 ft. at 20°C (68°F) ..... 86  
 testing ..... 122  
 test voltages for shielded power cables ..... 124  
**DC and AC resistance of copper conductors** ..... 89  
**Deca** ..... 254  
**Deformation** ..... 51  
**DEF STAN 02** ..... 218  
**DEF STAN 61-12** ..... 218  
**Degreaser solvents resistance** ..... 47  
**Degrees centigrade (celsius)** ..... 248  
**Degrees fahrenheit** ..... 248

**Delay skew** ..... 76  
**DEMKO**  
 (Danmarks Elektriske Materielkontrol) ..... 185, 190, 199  
**Department for Transport** ..... 217  
**Department of the Environment** ..... 217  
**Deutsche Kommission**  
**Elektrotechnik Informationstechnik** ..... 204  
**Deutsches Institut für Normung** ..... 202  
**Diameter of multiconductor cables** ..... 255  
**Diameters**  
 and cross-sectional areas of solid copper wire ..... 12  
 for common conductor sizes ..... 8  
**Dielectric** ..... 73, 75  
 constant ..... 34, 37, 51, 53, 256  
 constant of common wire and cable materials ..... 53  
 strength ..... 51  
**Dimensions and maximum allowable percent fill**  
**of electrical metallic tubing**  
 (EMT) ..... 110  
**DIN** ..... 202  
 47100\* color code for paired conductors  
 (with color repetition above 22) ..... 203  
 47100 color code for single conductors  
 (with color repetition above 44) ..... 202  
**Direct burial** ..... 84  
**Dissipation factor** ..... 51  
**DKE** ..... 204  
**Drum diameter** ..... 150  
**Dry nitrogen** ..... 126  
**Dual braid shield construction** ..... 59  
**Dual coax** ..... 74  
**Dual-rated aluminum compression connectors** ..... 134  
**Duct bank** ..... 111  
**Duofoil** ..... II  
**Duplex LC connector** ..... 138  
**Dutch**  
 plug configurations ..... 200  
 standards ..... 199

**E**

**E-1 color sequence for control cables** ..... 38, 39  
**E-2 color sequence** ..... 38, 40  
**E-4 color sequence for control cables** ..... 41  
**E-5 color sequence for control cables** ..... 41  
**ECA** ..... 165

<b>ECTFE</b>	
(Ethylene-Chlorotrifluoroethylene or Halar)	79
<b>Eddy currents</b>	233
<b>Efficiency of motor</b>	252
<b>EHS galvanized steel</b>	119
<b>Eidgenössisches Starkstrominspektorat</b>	210
<b>Electric</b>	
cables under fire conditions—circuit integrity	168
shipboard cable	175
submersible cable	169
<b>Electrical</b>	
characteristics	85
conductivity	6
connections	134
installations in ships	167, 169
properties	47
properties of circuits	252
systems	3
<b>Electromagnetic interference</b>	
(EMI)	57, 58, 78
<b>Electronic</b>	
cable	73
cable shielding	58
cable shields	56
Components, Assemblies and Materials Association	165
Industries Alliance	166
<b>ELFEXT</b>	76
<b>EMI</b>	
emissions	78
immunity	78
separation recommendations	217
<b>Emission shield</b>	56
<b>EN 60228</b>	189
<b>ENA</b>	217
<b>End</b>	
caps	157
seals	113
<b>Engineering notation</b>	254
<b>English to metric</b>	242
<b>Enterprise cabling installations</b>	137
<b>EP</b>	37
<b>EPDM</b>	37
<b>Epoxy</b>	
and polish connectors (heat-cured)	142
and polish connectors (snaerobic)	142
and polish connectors (UV cured)	142
<b>EPR</b>	
(Ethylene Propylene Rubber)	37, 50
versus XLPE	51
<b>Equation for calculating wire or cable area</b>	110
<b>Equipment trailing cables</b>	68
<b>Equivalent conductor spacing</b>	257
<b>ER</b>	
(exposed run)	84
<b>ERA Technology Ltd.</b>	217
<b>Ergs</b>	247
<b>ESTI (formerly SEV)</b>	210
<b>Ethylene Propylene Rubber</b>	
(EP, EPR, or EPDM)	37, 51
integral insulation and jacket for wire	163
jacket for wire and cable	163
<b>Ethylene vinyl acetate</b>	
(EVA)	35
<b>EU power plug configurations</b>	197
<b>European</b>	
Committee for Electrotechnical Standardization	189
Committee for Standardization	196
Union (EU) Standards	189
<b>EVA</b>	35
<b>Evaluation of the insulation of shielded power cable systems</b>	169
<b>EX</b>	70
<b>Exchange cables</b>	78
<b>Explosive</b>	
atmospheres (hazardous locations)	167
gas atmospheres	174, 189
<b>Extension grade (wire)</b>	69
<b>Extra-fine wire strands Class 6</b>	31
<b>Extra-high strength galvanized steel</b>	119
<b>Extruded</b>	
conductor shield	72
dielectric insulated power cable systems	161
insulation shield	72
<b>F</b>	
<b>FAA</b>	166
<b>Fanout/breakout cable</b>	141
<b>FAS 90</b>	230
<b>Fault</b>	
current requirements	73
locating	124
<b>FC Connector</b>	139

<b>FDDI Connector</b> .....	139	<b>Fixture wire(s)</b> .....	11, 173, 184
<b>Federal Aviation Administration</b> .....	166	<b>Flamarrest</b> .....	II
<b>FEP</b>		<b>Flame</b>	
(Flourinated Ethylene-Propylene) .....	34, 79, 182	propagation .....	174
Teflon .....	49	resistance .....	47
<b>Ferrule</b> .....	137	spread .....	178
<b>Festoon cable</b> .....	174	testing of wire and cable .....	169
<b>Fiber</b>		Tests .....	170
cable construction .....	141	travel and smoke of wires and cables for use in	
cladding .....	82	air-handling spaces .....	171
connector .....	137	<b>Flammability of polymers</b> .....	52
core .....	82	<b>Flange</b>	
diameter .....	140	diameter .....	156
distributed data interface .....	139	<b>Flange diameter</b> .....	150
distribution equipment .....	140	<b>Flat PVC</b> .....	189
port density .....	137	<b>Flexibility</b> .....	11
ribbon cable .....	138	<b>Flexible</b>	
<b>Fiberglass</b> .....	37	coax .....	74
<b>Fiber optic</b>		Cord & Fixture Wire .....	173
cables .....	172	cords .....	67
cables for outside plant use .....	173	Cords and Cables .....	183, 226
connectors .....	127, 137	cord type designations .....	67
Outside Plant Communications Cable .....	167	<b>Fluoropolymers</b> .....	34
premises distribution cables .....	173	<b>Foil shields</b> .....	58
selection .....	82	<b>Fondo para la Normalización y Certificación</b>	
Terminology .....	173	de Calidad .....	223
testing .....	127	<b>Foot-pounds</b> .....	247
type FSMA connectors .....	173	<b>For CT use</b> .....	84
types .....	81	<b>Fork lift</b> .....	157
<b>Fibrous coverings</b> .....	37	<b>Formulas and constants</b> .....	251
<b>Fieldbus for use in industrial control systems</b> .....	168	<b>FPL</b> .....	84
<b>Field testing</b> .....	169	<b>French</b>	
electric submersible pump cable .....	169	plug configurations .....	201
<b>Filled</b>		standards .....	200
buried wires .....	172	<b>Frequency range</b> .....	131
cables .....	78	<b>FT1 fire test</b> .....	232
Telephone Cable .....	172	<b>FT4 fire test</b> .....	180, 232
Telephone Cable with Expanded Insulation .....	172	<b>FT6 fire test</b> .....	232
<b>Fine wire strands Class 5</b> .....	31	<b>F type coax connector</b> .....	133
<b>Fire</b>		<b>Fusible Links</b> .....	172
alarm and signal cable .....	230	<b>Fusion splicing</b> .....	141
hazard testing .....	168		
ratings .....	232		
Resistive Cables ("Cl" Rated) .....	174		
safety tests .....	176		



## G

<b>Galvanized steel strand</b> .....	120, 182
<b>gases evolved during combustion of electric cables</b> .....	168
<b>Gasoline, kerosene, etc. resistance</b> .....	47
<b>Gas-Tube-Sign Cable</b> .....	174
<b>GB</b>	
5013 .....	240
5023 .....	240
<b>General Requirements—Canadian Electrical Code,</b>	
<b>Part II</b> .....	226
<b>Geometric</b>	
mean distance .....	257
mean radius of conductor .....	257
<b>German</b>	
plug configurations .....	204
standards .....	202
<b>Giga</b> .....	254
<b>Gold</b> .....	6
<b>Graded refractive index</b> .....	81
<b>Ground check (GC) conductor</b> .....	68
<b>Grounded systems</b>	
(100 percent insulation level) .....	71
<b>GSWB (galvanized steel wire braid)</b> .....	63
<b>GTO</b> .....	230
<b>GTO-5</b> .....	182
<b>Guard (G) connection</b> .....	125

## H

<b>H03VV-F3</b> .....	192
<b>H05V-U</b> .....	192
<b>H07V-R</b> .....	192
<b>Halar</b> .....	II
(ECTFE) .....	34, 35, 49
<b>Halogen content</b> .....	176
in typical insulation and jacket materials .....	52
of wires and cables .....	203
<b>Handheld LAN cable testers</b> .....	127
<b>Handling</b> .....	105
of cable reels .....	157
<b>Hard drawn</b> .....	10
<b>HAR (Harmonized) Approval</b> .....	189
<b>HAR mark</b> .....	189
<b>Harmonized</b>	
marks .....	190
standards .....	191

**Hazardous**

locations (Type MC-HL) .....	174
<b>Hazardous (classified) locations</b> .....	170, 174, 184
<b>Health Care Facilities Handbook</b> .....	171
<b>Heat</b>	
cure .....	140
release, flame spread and mass loss testing	
of insulating materials .....	164
resistance .....	47
<b>Heater cord</b> .....	11
<b>Heat-shrinkable tubing</b> .....	163
<b>Helically applied copper wire(s)</b>	
(shields) .....	57
<b>Henries</b> .....	253
<b>High-density</b>	
fiber counts .....	141
polyethylene .....	47
polyethylene insulation for wire and cable .....	163
<b>High dielectric strength</b> .....	36
<b>High-frequency applications</b> .....	10
<b>High-potential DC testing</b> .....	122
<b>High-strength galvanized steel</b> .....	119
<b>High-temperature</b> .....	10
hook-up wire .....	171
instrumentation and control cable .....	171
wire and cable types .....	70
<b>High temperatures</b> .....	10
<b>High-voltage</b>	
connectors .....	131
tests .....	122
<b>Hipot testing</b> .....	122
<b>Horsepower</b> .....	247, 252
to amperes .....	250
<b>HPN</b> .....	67
<b>HSJ</b> .....	67
<b>Hypalon (discontinued)</b> .....	III,
chlorosulfonated polyethylene (CSPE) .....	37, 50
<b>Hypot</b> .....	II

## I

<b>IACS</b> .....	252
<b>IBM cabling system</b> .....	78

<b>ICEA</b> .....	166
S-73-532 (NEMA WC57) .....	38
T-29-520 .....	177, 180
<b>ICONTEC</b> .....	221, 224
<b>Identification and use of cores of flexible cables</b> .....	189
<b>Identification threads</b> .....	189
<b>IEC</b>	
60228 .....	243
60332-3 .....	177
(International Electrotechnical Commission) .....	167, 185
stranding .....	31
<b>IEE</b> .....	217
wiring regulations .....	215, 217
<b>IEEE</b> .....	169
383 .....	177
400 .....	122
802.5 (token ring) .....	78
1202 .....	176, 177, 179, 180
<b>IET</b> .....	217
<b>Ignitability</b> .....	176
<b>Ignition temperature</b> .....	163
<b>Impedance</b> .....	74, 127, 131, 253
at 60 Hz for single copper conductor cables .....	92
matching .....	74
mismatches .....	127
<b>Impulse voltage tests on insulated conductors</b> .....	169
<b>IMQ</b>	
(Istituto Italiano del Marchio di Qualità) .....	185, 190, 205
<b>Including Effect of Shield Losses</b> .....	171
<b>Individual shields</b> .....	69
<b>Inductance</b> .....	253
<b>Inductive reactance</b> .....	92, 257
<b>Industrial machinery</b> .....	171
<b>Industry standards</b> .....	159, 161
<b>Informationstekniska Standardiseringen</b> .....	209
<b>Information Technology Equipment</b> .....	184
<b>Insertion</b>	
loss .....	76, 77
<b>Inside</b>	
cable .....	78
wiring cable .....	164
<b>Installation</b>	
and testing .....	103
methods .....	116
methods for generating station cables .....	169
of cable systems for Class 1E circuits in nuclear power generating stations .....	169
<b>Installation (Continued)</b>	
of cable systems in substations .....	169
of overhead transmission line conductors .....	169
termination, and testing of insulated power cable .....	169
<b>Installations on shipboard</b> .....	102
<b>Institute of Electrical and Electronics Engineers</b> (IEEE) .....	II, 169
<b>Instituto Argentino de Normalización y Certificación</b> .....	224
<b>Instituto Colombiano de Normas Técnicas</b> .....	224
<b>Instituto Portugues da Qualidade</b> .....	207
<b>Instrumentation</b>	
cable(s) .....	69, 167, 214
Systems and Automation Society .....	170
tray cable .....	174
Tray Cable: Type ITC .....	184
<b>Insulated</b>	
Cable Engineers Association (ICEA) .....	II, 166
flexible cords .....	214
<b>Insulating and sheathing materials of electric and optical cables</b> .....	168
<b>Insulation</b> .....	34
and jacket materials .....	47, 79
resistance (IR) .....	36, 123, 125
<b>Interference voltage</b> .....	58
<b>Interlocked armor</b> .....	62
<b>International</b>	
Electrotechnical Commission (IEC) .....	II, 167
Organization for Standardization .....	170
organizations .....	185
Telecommunication Union/Telecommunications Sector .....	170
<b>Interstices</b> .....	255
<b>Intrinsically Safe</b>	
electrical apparatus for explosive atmospheres .....	189
Systems .....	184
<b>Intrinsic safety</b> .....	170
<b>IPQ</b> .....	207
<b>IRAM</b> .....	221, 224
<b>Irish</b>	
plug configurations .....	205
standards .....	204
<b>Iron vs constantan</b> .....	70
<b>IR tests</b> .....	125
<b>ISA</b> .....	170
<b>ISO</b>	
(International Standard for Standardization) .....	170, 185
<b>Istituto Italiano del Marchio de Qualita</b> .....	205

**Italian**

plug configurations .....	206
standards .....	205
<b>ITC</b> .....	84, 174
<b>ITS</b> .....	209
<b>ITU-T</b> .....	170

**J**

<b>J1127</b> .....	172
<b>J1128</b> .....	172
<b>Jacket(s)</b> for power, instrumentation and control cables .....	34, 37
<b>Jamming</b> .....	113
<b>Jam ratio</b> .....	113
<b>Japanese</b> plug configuration .....	239
standards .....	239
standards association .....	239
<b>JIS</b> C3662 .....	239
C3663 .....	239
<b>Joules</b> .....	247
<b>JSA</b> .....	239
<b>Jumper cordage</b> (patch cable) .....	141
<b>JX</b> .....	70

**K**

<b>Kapton</b> .....	11
<b>KEMA</b> .....	190, 199
<b>KEMA, KEUR</b> (NV tot Keuring van Elektrotechnische Materialen) .....	185
<b>Kevlar</b> .....	11
<b>K-fiber</b> .....	37
<b>K FIBER</b> .....	11
<b>Kilo</b> .....	254
<b>Kilograms per kilometer</b> .....	247
<b>Kilovolt-amperes</b> .....	252
<b>Kilowatts</b> .....	252
<b>kVA to amperes</b> .....	249
<b>KX</b> .....	70
<b>Kynar</b> .....	11, 34
(PVDF) .....	35

**L**

<b>L-824-A, B, C</b> .....	166
<b>Ladder type cable tray</b> .....	144
<b>LAN cable testing</b> .....	127
<b>Largest possible conductor in cable interstices</b> .....	255
<b>Lashing wires</b> .....	120
<b>Latin and South America</b> .....	221
<b>LC connector</b> .....	138
<b>Lead-covered cables</b> .....	63
<b>Lead sheath</b> .....	63
<b>Lead sheathed power cables</b> .....	203
<b>Leakage current</b> .....	122
<b>Length, weight, area, power and energy</b> .....	246
<b>Life of the cable insulation</b> .....	57
<b>Lifting cable reels</b> .....	105
<b>Light output</b> .....	127
<b>Limited</b> combustible .....	84
<b>Limited-Combustible Cable</b> .....	174
<b>Limiting</b> Oxygen Index (LOI) .....	52
temperatures for Australian insulated cables .....	237
<b>Local area network (LAN) unshielded twisted-pair (UTP)</b> ..	127
<b>Local area networks (LANs)</b> .....	78
<b>Locate faults</b> .....	127
<b>Locating equipment</b> .....	124
<b>Locking plug configurations</b> .....	145
<b>Loc-Trac</b> .....	11
<b>LOI of common wire and cable materials</b> .....	52
<b>London Underground Limited</b> .....	218
<b>Loose buffer tube construction</b> .....	82
<b>Loose tube (loose buffer) cable</b> .....	141
<b>Low-density polyethylene</b> .....	47
<b>Low-smoke</b> fire-retardant cables .....	81
<b>Low-Smoke</b> Halogen-Free (LSHF) Polymeric Cable Jackets .....	167
<b>Low-temperature flexibility</b> .....	47
<b>Low Voltage</b> Battery Cable .....	172
Primary Cable .....	172
Ultra Thin Wall Primary Cable .....	172
<b>Lubricants</b> .....	113, 114
<b>Lucent connector</b> .....	138

**M**

**Machine Tool Wires and Cables**

(Type MTW) ..... 174

**Magnesium** ..... 6

**Marine**

Propulsion System Wiring ..... 172

Shipboard Cable ..... 174

**Maximum**

cable diameters for permissible conduit fill ..... 109

core weight ..... 119

permissible pulling length ..... 114

pulling tension ..... 111

**MC** ..... 182

**Measure attenuation** ..... 127

**Mechanical Transfer-Registered Jack** ..... 138

**Medium**

hard drawn ..... 10

Voltage Power Cable (Type MV) ..... 174, 183

**Mega** ..... 254

**Megger** ..... II

testing ..... 125

**Messenger**

breaking strength ..... 119

in aerial cable installations ..... 113

Supported Wiring ..... 183

weight ..... 119

**Metal Cable Tray Systems** ..... 144

**Metal-clad cable: Type MC** ..... 183

**Method 1 - Colored compounds with tracers** ..... 38

**Method 2 - Neutral colored compounds with tracers** ..... 38

**Method 3 - Neutral or single-color compounds**  
with surface printing of numbers and color designations 38

**Method 4 - Neutral or single-color compounds**  
with surface printing of numbers ..... 38

**Method 5 - Individual color coding with braids** ..... 38

**Method 6 - Layer identification** ..... 38

**Method 7 - Paired conductors** ..... 38

**Metric sizes** ..... 6

**Metric to English conductor size** ..... 242

**Mexican**

Code Standard for Electrical Installations ..... 222

plug configuration ..... 223

standards ..... 222

**MG** ..... 70

**MIC**

(media interface connector) ..... 139

**Micro** ..... 254

**Microbending** ..... 127

losses ..... 83

**Microphone cables** ..... 165

**Military**

wire and cable types ..... 80

**Milli** ..... 254

**MIL-Spec wire** ..... 80

**Mine**

power feeder cables (MPF) ..... 68

Safety and Health Administration ..... 170

**Mineral**

insulated cable(s) ..... 168, 189, 214, 226

**Minimum**

bending radius ..... 115

drum diameter as a multiple of outside diameter of cable ..... 150

**Mining cable** ..... 68

**Ministry of Defense** ..... 218

**MODUK** ..... 218

**Modular jack pair assignments for UTP** ..... 134

**Moisture**

absorption ..... 37

removal ..... 126

**Motor efficiency** ..... 250

**Moving and lifting** ..... 157

**MSHA** ..... 170

**MTP/MPO connectors** ..... 138

**MT-RJ connectors** ..... 138

**MTW** ..... 182

**Multiconductor color code**

(Belden Standard) ..... 43

**Multimode fiber** ..... 81, 82, 139, 140

**Multipair color code**

(Belden Standard) ..... 43

**Multi-sheave assemblies** ..... 118

**Munsell color standard** ..... 46, 166

**MV** ..... 84, 182

**Mylar** ..... II

**N**

**Nano** ..... 254

**National**

Electrical Code ..... 171, 183

Electrical Code Articles related to the wire and cable industry 183

Electrical Manufacturers Association (NEMA) ..... II

Electrical Safety Code (NESC) ..... 169

**National (Continued)**

Fire Protection Association (NFPA) .....	II, 171
Standards Authority of Ireland .....	204
<b>Naval Ship Engineering Center</b>	
(NAVSEC) .....	II
<b>NBR 5410</b> .....	224
<b>NEC</b> .....	II, 183, 199
Fire Test Summary .....	176
<b>NEMA</b> .....	171
non-locking plug configurations .....	145
plug and receptacle configurations .....	145
WC 26 (EEMAC 201) .....	151
WC 50 .....	166
WC 51 .....	166
WC 53 .....	167
WC 54 .....	167
WC 55 .....	167
WC 57 .....	167
WC 58 .....	167
<b>NEMKO</b>	
(Norges Elektriske Materalknotroll) .....	185, 190, 206
<b>Neoprene</b>	
(CP) .....	36, 50
<b>NESC</b> .....	169
<b>Netherlands Electro-Technical Committee</b> .....	199
<b>Network Rail</b> .....	218
<b>Newtons</b> .....	247
<b>New Zealand Wiring Rules</b> .....	236
<b>NEXT</b> .....	76, 77
<b>NFPA</b> .....	171
262 .....	176, 178
<b>Nickel</b> .....	6
coatings .....	10, 86
<b>Nicrosil</b> .....	II
<b>Nisil</b> .....	II
<b>NM</b> .....	182
<b>NMX-J-451-ANCE</b> .....	222
<b>No epoxy/no polish connectors</b> .....	140, 142
<b>NOM-001-SEDE</b> .....	222
<b>Nomex</b> .....	II
<b>Nonmetallic-sheath cables</b> .....	174
<b>Nonshielded</b>	
Cables Rated 2,001 - 5,000 Volts .....	171
Power Cables Rated 2,000 Volts or Less .....	171
<b>Norges Elektriske Materiealkontroll</b> .....	206

**Norwegian**

plug configurations .....	207
Post and Telecommunications Authority .....	206
standards .....	206
<b>NPLF</b> .....	84
<b>NPT</b> .....	206
<b>NSAI</b> .....	190, 204
<b>N series coax connectors</b> .....	133
<b>NTC 2050</b> .....	224
<b>Nuclear radiation resistance</b> .....	47
<b>Number of conductors in electrical metallic tubing</b> .....	106
<b>Number of strands</b> .....	17, 18, 21
<b>N.V. tot Keuring van Elektrotechnische Materialen</b> .....	199
<b>Nylon</b> .....	48

**O**

<b>OFN</b> .....	84
<b>Ohm</b> .....	2
<b>Ohm's Law</b> .....	2
<b>Ohms per</b>	
1,000 feet .....	247, 252
kilometer .....	247
<b>Oil</b>	
resistance .....	47
resistant .....	84
<b>Operating temperature range</b> .....	74
<b>Optical</b>	
attenuation .....	82
cable innerduct .....	164
density of smoke generated by solid materials .....	164
fiber and optical fiber cable .....	164
fiber cable designs .....	83
fiber cable(s) .....	78, 81, 167, 174, 227
Fiber Cables and Raceways .....	184
fiber cable selection .....	82
fiber cable splice closures .....	173
fiber cables under fire conditions .....	168
fiber types .....	81
power .....	82
power meters .....	127
radiation .....	81
wave guides .....	81
<b>Optical time domain reflectometers</b>	
(OTDRs) .....	127
<b>Österreichischer Verband für Elektrotechnik</b> .....	197
<b>OTDR</b> .....	127

**Outer cladding layer** ..... 81

**Outer shield**  
 (insulation shield) ..... 56

**Outside cable** ..... 78

**ÖVE**  
 (Österreichischer Verband für Elektrotechnik) ..... 190, 197

**Overall diameter of a group of round conductors** ..... 255

**Overall shield** ..... 69

**Oxidation resistance** ..... 47

**Oxide inhibiting compression connectors** ..... 134

**Oxygen** ..... 52  
 concentration to support candle-like combustion  
     of plastics (oxygen index) ..... 163  
 consumption calorimeter ..... 164  
 content of air ..... 52  
 Index Test ..... 170

**Ozone resistance** ..... 37, 47

**P**

**Packaging of wire and cable** ..... 149

**Pair assignments** ..... 134

**Parallel connections** ..... 253

**Partial discharge(s)** ..... 56, 168

**PASP cable** ..... 165

**Payoff reel** ..... 113

**PD**  
 (partial discharge) ..... 122

**PE-7** ..... 172

**PE-39** ..... 172

**PE-86** ..... 172

**PE-89** ..... 172

**PE-90** ..... 172

**Peak smoke release rate** ..... 177

**Percent fill** ..... 110

**Performance categories** ..... 76

**PFA** ..... 34

**Phase-to-ground fault** ..... 71

**Pico** ..... 254

**Picofarads per foot** ..... 256

**PIC screened cable** ..... 164

**Plenum**  
 flame test ..... 232  
 (NPFA 262) ..... 176  
 PVC ..... 48  
 rated cable ..... 178

**PLTC** ..... 84, 182

**Plug configuration(s)** ..... 145, 146, 147, 196, 197, 198, 199,  
 200, 201, 204, 205, 206, 207, 208, 209, 210, 211, 219, 223, 231,  
 221, 236, 237, 238, 239

**PO** ..... 35

**Polyamid** ..... 37

**Polyaramid** ..... 37

**Polyethylene**  
 jacket for electrical insulated wire and cable ..... 163  
 (PE) ..... 35, 79

**Polyolefins**  
 (PO) ..... 35

**Polypropylene**  
 (PP) ..... 35, 47, 79

**Polyurethane**  
 (PUR) ..... 35, 48

**Polyvinyl chloride**  
 Jacket for Wire and Cable ..... 163  
 (PVC) ..... 34, 79

**Portable**  
 and power feeder cables for use in mines ..... 167  
 cables ..... 68  
 cord ..... 11  
 cord terminology ..... 67  
 power and control ..... 67  
 power cable ..... 174

**Portuguese**  
 plug configurations ..... 208  
 standards ..... 207

**Pound-force** ..... 247

**Pounds per 1,000 feet** ..... 247, 252

**Power**  
 and Control Tray Cables (Type TC) ..... 174, 183  
 cable ..... 71  
 cable 15 kV through 69 kV ..... 166  
 cable ampacities ..... 166  
 cable ampacity tables ..... 102, 169  
 cables, 69 through 138 kV ..... 161  
 cables and accessories Rated above 46 kV through 345 kV ..... 161  
 cables for rated voltages from 1 kV to 30 kV ..... 168  
 cable shielding ..... 56, 57  
 cables rated 5 through 46 kV ..... 161, 167  
 connectors ..... 134  
 factor ..... 253  
 factor of load ..... 252

**Power-limited circuit(s)** ..... 173, 184

**PP** ..... 35

PPE	182
Preassembled aerial cable	111
Pre-connectorized patch panels	138
Premises	
distribution wiring	78
optical fiber cable	164
Proof testing	122
Propagation	176
delay	76, 77
Proper handling of cable reels	157
Properties	
of EPR compared with those of XLPE	51
of thermoplastic insulation and jacket materials	47
of thermoset insulation and jacket materials	50
PSAACRF	77
PSACRF	77
PSANEXT	77
PSELFEXT	76
PSNEXT	77
(dB)	76
PTFE (TFE) Teflon	34, 49
Pulleys	118
Pulling	111
eyes	111
force	111
grip	111
interlocked armor cable	111
lubricants	114
swivel	111
tension	111
tension calculations	113
PUR	35
Purging water from conductor	126
PVC	
insulated cables of rated voltages up to	
and including 450/750 V	167
(polyvinyl chloride)	34, 47, 79
<b>R</b>	
R90	228
RA90	228
Radar	124
Radiant Cone Flame Test	170
Radiation resistance	35
Railway Industry Association	218
R-CPE-90	237
REA	172
Reactance	253
and impedance at 60 Hz	92
Receiving, handling and storage	105
Receptacle configurations	145
Recognized national standards	191
Recreational Vehicle Cable	174
Reduced diameter extruded dielectric shielded	
power cables rated 5 through 46 kV	161
Reel	
dimensions	156
handling	157
size	150
terminology	150
weight	156
Reflections	74
Regulatory and approval agencies	182
R-EP-90	237
Residual voltage	122
Resistance	
and ampacity at 400 and 800 Hz	100
and capacitance in series (R and C)	253
and inductance in series (R and L)	253
and weight of conductors	252
inductance and capacitance in AC circuits	253
inductance and capacitance in series (R, L and C)	253
of aluminum conductors	91
of copper conductors	89
(R)	253
Resistivity of Electrical Conductor Materials	162
Retractable cords	35
Return loss	76
RHW	182
RHW-2	68, 84, 182
RIA	218
Ribbon cable	137, 141
Riser	
cable	164
flame test	179
(UL 1666)	176
RJ11 and RJ45 modular plugs and jacks	133
Roll direction	105
Rollers	113
Rope-Lay-Stranded Copper Conductors	
(Bunch Stranded Members)	11, 162
(Concentric Stranded Members)	11, 162

Rope strand	7
Rubber insulated cables of rated voltages up to and including 450/750 V	168
Rural Utilities Service	172
RUS	172
RW90	228
RWU90	229

**S**

SAA	236
SAE International	172
Safety in high voltage and high power testing	169
Sag	119
SCC	227
SC Connector	137, 140
Schweizerische Normen-Vereinigung	210
Scotch	11
Scotchlok	11
Sector conductor	7
Segmental conductor	7
Semiconductive shields	56
Semirigid	
cable	131
coax	74
SEMKO	
(Svenska Elektriska Materielkontrollanstalten)	185, 190, 209
SEO	67, 182
Series and parallel connections	253
Serve shields	59
Service drop	78
Service entrance cables	174, 183
SETI	
(Electrical Inspectorate Sakiniementie)	185
SEV	
(Schweizerischen Electrotechnischen Verein)	185
Seven-conductor cable for ABS power	172
SF-2	70
SFF-2	70
SHD cables	68
Sheave	111
assembly	118
Shielded	
cables	78
twisted pair (STP)	76
twisted-pair (STP) cabling	127

Shielding	
at high frequencies	58
effectiveness	58
practice for low voltage cables	169
Shields	55
Shield short circuit current	99
Shipboard cable	175
Shipboard cables	63, 81
Shipping reels	152
Short circuit	
current for copper and aluminum conductors	96
current for copper shielding tape	99
current rating	96
current(s)	72, 96, 168
performance of metallic shields and sheaths	166
time	99
Short-circuit temperature limits	168
Shovel (SHD) cables	68
Shrinkback	51
“Shuko” European	197
SHV connectors	131
Sidewall pressure	
(SWP)	111, 113, 114
Signal leakage	58
Silicone	37
rubber	50
Silver	6
plated	10, 86
Singapore	
plug configurations	238
standards	238
Singlemode	
optical connectors	164
Single conductor high-current armored cables	233
Single-mode	
connectors	140
fiber	81
Single sheaves	118
SIS	182
SJ	67
SJE	67
SJ00W	67
SJT	67
SJTO	67
SMA connector(s)	132, 139



<b>Small form factor (SFF) connectors</b> .....	137
<b>Small reel dimensions</b> .....	156
<b>Smoke</b> .....	176
density .....	178
density of burning cables .....	168
release rates .....	164
<b>SNV</b> .....	210
<b>SO</b> .....	67
<b>Society of Automotive Engineers</b> .....	172
<b>Soft or annealed copper wire</b> .....	10, 162
<b>Solderability</b> .....	10
<b>Solef</b> .....	11
(PVDF) .....	34
<b>Solef/Kynar</b> .....	49
(PVDF)/PVF .....	8
<b>Solid</b> .....	8
aluminum .....	22
conductor .....	8
copper .....	12
<b>SOO</b> .....	182
<b>SOOW</b> .....	67
<b>South America</b> .....	221
<b>Spacings for conductor supports</b> .....	121
<b>Spanish</b> .....	209
plug configurations .....	208
standards .....	67
<b>SPE-1</b> .....	59
<b>Spiral (serve) shield</b> .....	150
<b>Spool size</b> .....	67
<b>SPRING Singapore</b> .....	238
(formerly PSB) .....	67
<b>SPT-1</b> .....	6, 246
<b>Square millimeters</b> .....	70
<b>SRG</b> .....	70
<b>SRGK</b> .....	70
<b>SRK</b> .....	74
<b>SRL</b> .....	238
<b>SS299 Part 1</b> .....	238
<b>SS358</b> .....	119
<b>Stainless steel</b> .....	140
tips .....	164
<b>STALPETH</b> .....	242
<b>Standard English Sizes</b> .....	242
(kcmil) .....	242
<b>Standard metric sizes (mm<sup>2</sup>)</b> .....	242
<b>Standards</b> .....	236
Australia .....	227
Council of Canada .....	214
<b>Standards organizations</b> .....	74
<b>Standing waves</b> .....	79, 164
<b>Station wire</b> .....	169
<b>Statistical analysis of thermal life test data</b> .....	137
<b>ST Connector</b> .....	164
<b>Steam resistant cable</b> .....	79, 178
<b>Steiner Tunnel Flame Test</b> .....	182
<b>STO</b> .....	182
<b>STOOW</b> .....	105
<b>Storage</b> .....	157
and shipment .....	137
<b>Straight tip connector</b> .....	11, 86
<b>Strand</b> .....	88
classe(s) .....	7
classes B, C, D, H, I and K .....	26
types .....	26
<b>Stranding</b> .....	26
diameter, area and DC resistance (32 through 4/0 AWG) .....	28
diameter, area, DC resistance and weight (20 AWG through 2,000 kcmil) .....	11
<b>Strand Properties</b> .....	83
<b>Strength members</b> .....	56
<b>Stress control layer</b> .....	74, 79
<b>Structural Return Loss</b> .....	78
(SRL) .....	136
<b>Structured building wiring system</b> .....	63
<b>Stud sizes</b> .....	169
<b>Submarine cable</b> .....	137
<b>Submersible pump cable</b> .....	51, 84
<b>Subscriber connector</b> .....	121
<b>Sunlight resistant</b> .....	143
<b>Support spacing for conductors in vertical raceways</b> .....	121
<b>Support span</b> .....	67
<b>Suspended cables</b> .....	209
<b>SVE</b> .....	67
<b>Svenska Elektriska Materielkontrollanstalten</b> .....	67
<b>SVT</b> .....	63
<b>SWA (steel wire armor)</b> .....	210
<b>Swedish</b> .....	209
plug configurations .....	209
standards .....	

**Swiss**  
 plug configurations ..... 211  
 standards ..... 210  
**Symbols of international organizations** ..... 185  
**Synthetic rubber** ..... 36

**T**

**T90 NYLON** ..... 228, 229  
**Table E-2** ..... 38  
**Table K-1** ..... 38  
**Tape shielded 15 kV power cable** ..... 72  
**TC** ..... 84, 182  
**TCGT** ..... 70  
**TDRs** ..... 124  
**TECK 90**  
 cable ..... 226, 228  
 terminations ..... 233  
**Teflon** ..... II, 34  
 FEP ..... 34  
 PFA ..... 34  
 PTFE ..... 34  
**Tefzel** ..... II  
 (ETFE) ..... 34, 35, 49  
**Telcordia** ..... 164  
**Telecommunication**  
 cable color code (band marked) ..... 46  
 cable color code (solid colors) ..... 46  
 color codes ..... 46  
 power cable ..... 164  
**Telecommunication Industries Association** ..... 173  
**Telecommunications Cabling Standard** ..... 173  
**Telephone**  
 cables ..... 78  
**Temperature**  
 coefficient of copper ..... 94  
 coefficient of resistance ..... 94  
 conversion ..... 248  
 correction factors for the resistance of copper conductors ..... 94  
 range of cable polymers ..... 51  
 rise ..... 101  
**Tensile**  
 load ..... 83  
 strength of copper wire ..... 10  
**Tension limitations** ..... 111  
**Tera** ..... 254  
**Terminal stud size chart** ..... 136

**Termination**  
 leakage current ..... 123  
 methods ..... 141  
 of Single Phase Single-Conductor Teck 90 Cables ..... 233  
**Testing at high voltage** ..... 122  
**Tests conducted during and after installation** ..... 124  
**Textile braid** ..... 37  
**TFE** ..... 182  
**TFFN** ..... 182  
**TFN** ..... 182  
**TGGT** ..... 70  
**Thermal**  
 conductivity ..... 6  
 expansion ..... 51  
 properties ..... 51  
**Thermocouple**  
 connectors ..... 69  
 junction ..... 69  
 types ..... 69  
 wire ..... 69, 80  
**Thermoplastic-Insulated Wires and Cables** ..... 173, 226  
**Thermoplastic(s)** ..... 34, 47  
 cords ..... 67  
 CPE ..... 34  
 elastomer (TPE) ..... 35  
**Thermoset-Insulated Wires and Cables** ..... 173, 226  
**Thermoset(s)** ..... 50  
 CPE ..... 34, 36, 50  
 insulated, armored cables having low emission of smoke  
     and corrosive gases ..... 214  
 portable cords ..... 67  
**Thermosetting polyethylene insulation for wire and cable** ..... 164  
**THHN** ..... 182  
**Threaded coupling** ..... 131  
**Three phase**  
 delta ..... 3  
 star ..... 3  
 wye ..... 3  
**THW** ..... 182  
**THW-2** ..... 182  
**THWN** ..... 68  
**THWN-2** ..... 182  
**TIA** ..... 173  
**TIA-568-B.1** ..... 173  
**TIA-568-B.2** ..... 76  
**Tight buffer** ..... 83

<b>Tight-buffered cable</b> .....	141
<b>Time Domain Reflectometer (TDR)</b> .....	124, 127
<b>Time-leakage current test</b> .....	122
<b>Tin</b> .....	10
plated .....	86
<b>Tinned soft or annealed copper wire</b> .....	162
<b>Tinsel conductor</b> .....	191
<b>Tip and ring</b> .....	78
<b>TKGT</b> .....	70
<b>TMMG</b> .....	70
<b>TNC</b> .....	131
connector .....	131
<b>Token ring protocol</b> .....	139
<b>Total smoke released</b> .....	177
<b>Toxicity</b> .....	176
Testing of Fire Effluents .....	170
<b>TPE</b> .....	35
<b>TPR</b> .....	35
<b>Trademarks</b> .....	II
<b>Trailing cables for mining purposes</b> .....	214
<b>Transfer impedance testing</b> .....	171
<b>Transit time of signals</b> .....	74
<b>Transmission lines</b> .....	165
<b>Transmitted intensity</b> .....	82
<b>Traverse</b> .....	150, 156
<b>Tray</b>	
cable listings and markings .....	84
cables .....	84
cover .....	144
material and finish .....	143
rating .....	84
types .....	143
<b>Tree retardant</b> .....	51
<b>Trees</b> .....	56
<b>Tree wire</b> .....	165
<b>Triaxial cable</b>	
(triax) .....	74
<b>Twinaxial</b>	
cable (twinax) .....	75
<b>TWU75</b> .....	228
<b>TX</b> .....	70
<b>Type</b>	
CM .....	79
CMP .....	79
CMR .....	79
CMX .....	79
<b>Type (Continued)</b>	
E (chromel vs constantan) .....	69
G .....	68
J (iron vs constantan) .....	69
K (chromel vs alumel) .....	69
R and S (platinum vs rhodium) .....	69
TC .....	84
T (copper vs constantan) .....	69
TECK 90 Cable .....	226
UF .....	34
W .....	68
<b>Tyryn</b> .....	II
<b>U</b>	
<b>UF</b> .....	182
<b>UHF</b>	
coax connectors .....	132
<b>UL 910 Fire Test</b> .....	178
<b>UL 1581 Vertical Tray Fire Test</b> .....	176, 180
<b>UL 1666 Riser Flame Test</b> .....	179
<b>UL 1685 Fire Test</b> .....	176, 177, 179, 180
<b>UL Listing(s)</b> .....	182
<b>UL Marks</b> .....	182
<b>UL (Underwriters Laboratories) Symbols</b> .....	185
<b>Underground burial</b> .....	47
<b>Underwriters Laboratories</b>	
(UL) .....	II, 182
<b>Ungrounded</b>	
Eurocord .....	197
systems (133 percent insulation level) .....	71
<b>UniBlend</b> .....	II
<b>Union Technique de l'Electricité</b> .....	200
<b>UniShield</b> .....	II
<b>UniStrand</b> .....	II
<b>United Kingdom</b> .....	213
plug configurations .....	219
<b>Unshielded</b>	
twisted pair (UTP) .....	76
(UTP) cable .....	78
<b>U.S.</b>	
Bureau of Mines .....	37
government specifications .....	175
<b>USE</b> .....	182
<b>USE-2</b> .....	68
<b>USE190</b> .....	230

**TE**  
 (Union Technique de L'Électricité) . . . . . 185, 190, 200

**UV cure** . . . . . 140

**V**

**V-90** . . . . . 237

**Valox** . . . . . II

**VCSEL**  
 (vertical cavity surface emitting laser) . . . . . 81

**VDE**  
 (Verband Deutscher Elektrotechnischer) . . . . . 185, 190, 203

**Velocity of propagation** . . . . . 74

**Venezuelan**  
 National Electrical Standard (Código Eléctrico Nacional) . . . . . 223  
 standards . . . . . 223

**Ventilated trough-type cable tray** . . . . . 144

**Verband Deutscher Elektrotechniker** . . . . . 203

**Vertical**  
 suspension . . . . . 121  
 Tray Flame Test . . . . . 84, 179

**Vertical Cable Tray Flame Tests**  
 (70,000 BTU/Hour) . . . . . 167  
 (210,000 BTU/Hour) . . . . . 167

**Vertical cable tray tests** . . . . . 177

**Vertical-specimen flame test** . . . . . 181

**Vertical-tray fire-propagation and smoke-release test** . . . . . 174

**VLF**  
 (very low frequency) . . . . . 122

**Voice grade media**  
 (VGM) . . . . . 78

**Volt** . . . . . 2

**Voltage**  
 drop . . . . . 71, 95  
 drop considerations . . . . . 72  
 drop in percent . . . . . 95  
 drop per amp per 100 ft. of circuit . . . . . 95  
 rating . . . . . 71, 74

**Voltage Standing-Wave Ratio**  
 (VSWR) . . . . . 74, 131

**Volume**  
 resistivity . . . . . 167  
 resistivity of the insulation shield . . . . . 56

**VSWR** . . . . . 74

**VW-1** . . . . . 176, 181

**VW-1 flame test** . . . . . 181

**W**

**W** . . . . . 182

**Water**  
 resistance . . . . . 47  
 vapor . . . . . 126

**Watertight construction** . . . . . 81

**Watt-hours** . . . . . 247

**Watts** . . . . . 247

**Wavelength** . . . . . 82

**WC 57** . . . . . 171

**WC 66** . . . . . 171

**WC 70** . . . . . 171

**WC 71** . . . . . 171

**Weatherproof caps** . . . . . 105

**Weather, sun resistance** . . . . . 47

**Welding cable** . . . . . 11, 182

**Wet location** . . . . . 84

**Wire**  
 connectors . . . . . 173  
 pulling compounds . . . . . 113  
 serve armor . . . . . 63

**Wire and Cable**  
 covered by UL Standards . . . . . 182  
 Packaging . . . . . 151, 171  
 packaging standards . . . . . 151  
 Test Methods (Trinational) . . . . . 174

**Withstand test** . . . . . 122

**Working load** . . . . . 143

**X**

**X-HF-90** . . . . . 237

**XHHW** . . . . . 182

**XHHW-2** . . . . . 68, 84, 182

**XLP** . . . . . 36

**XLPE** . . . . . 36

**Z**

**Z-Fold** . . . . . II

**Z-Fold foil shield** . . . . . 58

**Zinc** . . . . . 6

**Zytel** . . . . . II





**Anixter's Global Presence** Anixter is located in over 260 cities around the world in more than 50 countries.



### Corporate Snapshot:

Year founded: **1957** | Number of employees: **Over 8,200** | 2011 Revenues: **\$6.1 billion** | Products: **More Than 450,000**  
 Inventory: **Over \$1 billion** | Customers: **Over 100,000** | Stock symbol: **AXE** | Countries: **More Than 50** | Fortune 500 List

### Anixter Association and Committee Memberships

- Telecommunications Industry Association (TIA)
- International Organization for Standardization (ISO)
- Institute of Electrical & Electronics Engineers (IEEE)
- Open Network Video Interface Forum (ONVIF)
- The Green Grid
- Building Industry Consulting Services International (BICSI)
- Security Industry Association (SIA)
- Control Systems Integrators Association (CSIA)

### Technical Certifications

- More than 100 Registered BICSI RCDDs
- PSPs (Physical Security Professional Certification)
- CCNAs (Cisco Certified Network Associate)

#### NORTH AMERICA – USA

**Worldwide HQ**  
 Glenview, IL  
 224.521.8000

#### CANADA HQ

**Toronto, Ontario**  
 905.568.8999

#### LATIN AMERICA HQ

**Glenview, IL**  
 224.521.8000

#### EUROPE/MIDDLE EAST/AFRICA HQ

**Enterprise Cable & Security HQ**  
 Uxbridge, England  
 +44.1895.818181

**Wire & Cable HQ**  
 Warrington, England  
 +44.1825.838658

**Fasteners HQ**  
 Gloucester, England  
 +44.1452.880500

#### ASIA/PACIFIC

**Asia/Pacific HQ**  
 Singapore  
 +65.6508.1600

**South Pacific HQ**  
 Sydney, Australia  
 612.9.333.0800

#### INTERNATIONAL SERVICES

**Glenview, IL**  
 224.521.8000

#### AFTER HOURS

**USA**  
 800.323.8167

**Canada**  
 800.361.0250

#### USA

**Alabama**  
 Dadeville

**Alaska**  
 Anchorage

**Arizona**  
 Nogales  
 Phoenix

**Arkansas**  
 Fort Smith

**California**  
 Anaheim  
 Burbank  
 Fresno  
 Los Angeles  
 Pleasanton  
 Sacramento  
 San Diego  
 San Jose

**Colorado**  
 Denver

**Connecticut**  
 Cheshire

**Florida**  
 Delray Beach  
 Fort Lauderdale  
 Jacksonville  
 Miami

**Georgia**  
 Americus  
 Atlanta  
 Dublin  
 Vidalia

**Idaho**  
 Boise

**Illinois**  
 Bloomington  
 Mount Prospect  
 Princeton  
 Wood Dale

**Indiana**  
 Columbus  
 Fort Wayne  
 Indianapolis

#### Iowa

Des Moines  
 Hesston

**Kentucky**  
 Cadiz  
 Louisville

**Louisiana**  
 New Orleans

**Maryland**  
 Baltimore

**Massachusetts**  
 Boston

**Michigan**  
 Detroit  
 Grand Rapids

**Minnesota**  
 Eden Prairie  
 Minneapolis  
 Thief River Falls  
 Windom

**Mississippi**  
 Gulfport

**Missouri**  
 Kansas City  
 St. Louis

**Nebraska**  
 Grand Island  
 Omaha

**Nevada**  
 Las Vegas

**New Hampshire**  
 Nashua  
 Salem

**New Jersey**  
 Cranbury  
 Florham Park

**New Mexico**  
 Albuquerque  
 New York

Albany  
 Rochester

#### Ohio

Ashland  
 Chillicothe  
 Cincinnati  
 Cleveland  
 Columbus

**Oklahoma**  
 Tulsa

**Oregon**  
 Portland

**Pennsylvania**  
 Allentown  
 Erie  
 Lewisberry  
 Philadelphia  
 Pittsburgh

**South Carolina**  
 Greenville  
 North Charleston

**Tennessee**  
 Jackson  
 Memphis  
 Nashville

**Texas**  
 Delray Austin  
 Dallas  
 El Paso  
 Houston  
 McAllen  
 San Antonio  
 Tyler

**Utah**  
 Salt Lake City

**Virginia**  
 Dulles  
 Norfolk  
 Richmond

**Washington**  
 Renton  
 Seattle

**Wisconsin**  
 Appleton  
 Kenosha  
 Manitowoc  
 Milwaukee  
 Tomah

#### CANADA

**Alberta**  
 Calgary  
 Edmonton

**British Columbia**  
 Vancouver

**Manitoba**  
 Winnipeg

**Nova Scotia**  
 Halifax

**Newfoundland**  
 St. John's

**Ontario**  
 Hamilton  
 Kitchener  
 London  
 Ottawa  
 Toronto  
 Sudbury  
 Thunder Bay

**Quebec**  
 Abitibi  
 Montreal  
 Quebec City

**Saskatchewan**  
 Saskatoon

**LATIN AMERICA**

**Argentina**  
 Buenos Aires  
 Cordoba

**Brazil**  
 Curitiba  
 São Paulo

**Chile**  
 Miami, FL

**Colombia**  
 Bogotá

**Costa Rica**  
 San Jose

**Dominican Republic**  
 Santo Domingo

#### Mexico

Aguascalientes  
 Guadalajara  
 Juarez  
 Mexicali  
 Mexico City  
 Monterrey

**Panama**  
 Panama City

**Peru**  
 Arequipa  
 Lima

**Puerto Rico**  
 San Juan

**Venezuela**  
 Caracas

**Uruguay**  
 Barbados

**EUROPE/MIDDLE EAST/AFRICA**

**United Kingdom**  
 Aberdeen  
 Barrow in Furness  
 Belfast  
 Birmingham  
 Bredbury  
 Chesterfield  
 Coventry  
 Diss  
 Dorset  
 Edinburgh  
 Ellesmere Port  
 Gateshead  
 Glasgow  
 Gloucester  
 Leeds  
 Liverpool  
 Luton  
 Newtonabbey  
 Nottingham  
 Peterborough  
 Plymouth  
 Rotherham  
 Sheffield  
 Uxbridge  
 Warrington

#### Austria

Vienna

**Belgium**  
 Willebroek

**Czech Republic**  
 Prague

**Denmark**  
 Ansej  
 Copenhagen

**Finland**  
 Helsinki

**France**  
 Lyon  
 Paris  
 Sarreguemines

**Germany**  
 Bielefeld  
 Dillingen  
 Frankfurt  
 Mannheim  
 Stuttgart

**Hungary**  
 Budapest

**Republic of Ireland**  
 Dublin

**Italy**  
 Bari  
 Brescia  
 Milan  
 Reggiolo  
 Rovereto

**Morocco**  
 Casablanca

**Netherlands**  
 Capelle aan den IJssel

**Norway**  
 Oslo

**Poland**  
 Warsaw

**Portugal**  
 Lisbon

#### Sweden

Gothenburg  
 Stockholm

**Switzerland**  
 Montreux  
 Zurich

**Turkey**  
 Istanbul

**United Arab Emirates**  
 Dubai  
 Oman  
 Qatar

**ASIA/PACIFIC**

**Australia**  
 Brisbane  
 Melbourne  
 Perth  
 Sydney

**China**  
 Beijing  
 Shanghai  
 Shenzhen  
 Suzhou

**Hong Kong**  
 India

Bangalore  
 Chennai  
 Mumbai  
 New Delhi

**Indonesia**  
 Jakarta

**Japan**  
 Tokyo

**Malaysia**  
 Kuala Lumpur  
 Penang

**New Zealand**  
 Auckland

**Philippines**  
 Manila

**Singapore**  
 Singapore

#### Taiwan

Taipei

**Thailand**  
 Bangkok

**Vietnam**  
 Ho Chi Minh



The mark of  
responsible forestry