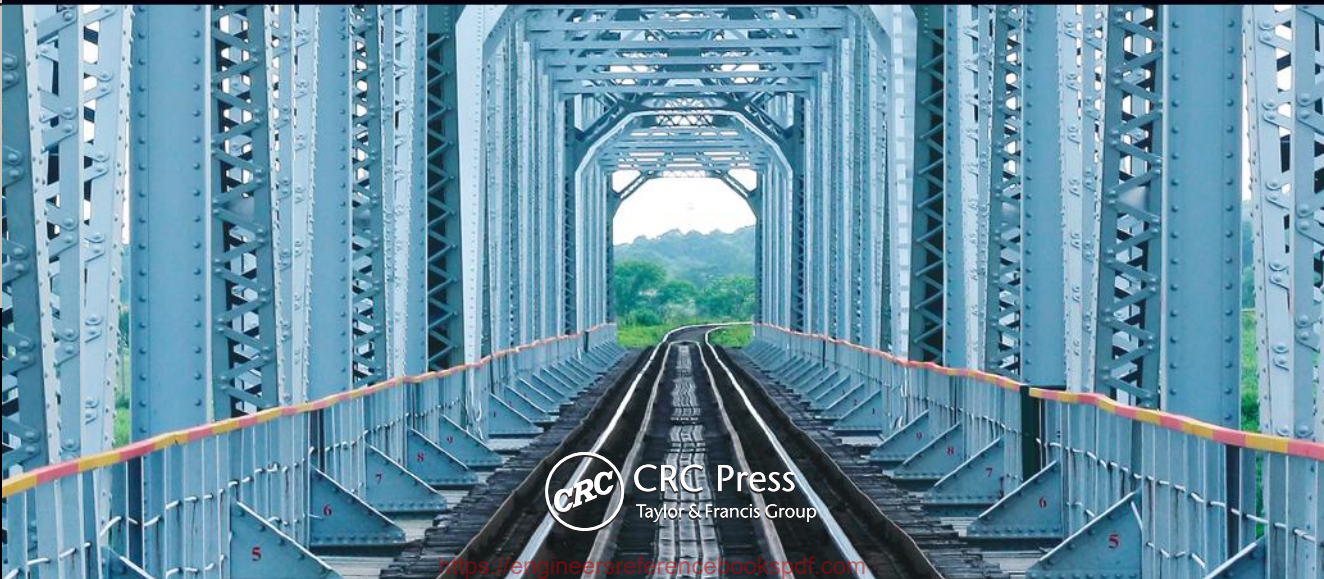


**SECOND EDITION**

# Principles of STRUCTURAL DESIGN

Wood, Steel, and Concrete

**RAM S. GUPTA**



CRC Press  
Taylor & Francis Group



SECOND EDITION

---

Principles of  
**STRUCTURAL  
DESIGN**

Wood, Steel, and Concrete



SECOND EDITION

---

Principles of  
**STRUCTURAL  
DESIGN**

Wood, Steel, and Concrete

RAM S. GUPTA



**CRC Press**

Taylor & Francis Group

Boca Raton London New York

---

CRC Press is an imprint of the  
Taylor & Francis Group, an **informa** business

CRC Press  
Taylor & Francis Group  
6000 Broken Sound Parkway NW, Suite 300  
Boca Raton, FL 33487-2742

© 2014 by Taylor & Francis Group, LLC  
CRC Press is an imprint of Taylor & Francis Group, an Informa business

No claim to original U.S. Government works  
Version Date: 20140213

International Standard Book Number-13: 978-1-4665-5233-3 (eBook - PDF)

This book contains information obtained from authentic and highly regarded sources. Reasonable efforts have been made to publish reliable data and information, but the author and publisher cannot assume responsibility for the validity of all materials or the consequences of their use. The authors and publishers have attempted to trace the copyright holders of all material reproduced in this publication and apologize to copyright holders if permission to publish in this form has not been obtained. If any copyright material has not been acknowledged please write and let us know so we may rectify in any future reprint.

Except as permitted under U.S. Copyright Law, no part of this book may be reprinted, reproduced, transmitted, or utilized in any form by any electronic, mechanical, or other means, now known or hereafter invented, including photocopying, microfilming, and recording, or in any information storage or retrieval system, without written permission from the publishers.

For permission to photocopy or use material electronically from this work, please access [www.copyright.com](http://www.copyright.com) (<http://www.copyright.com/>) or contact the Copyright Clearance Center, Inc. (CCC), 222 Rosewood Drive, Danvers, MA 01923, 978-750-8400. CCC is a not-for-profit organization that provides licenses and registration for a variety of users. For organizations that have been granted a photocopy license by the CCC, a separate system of payment has been arranged.

**Trademark Notice:** Product or corporate names may be trademarks or registered trademarks, and are used only for identification and explanation without intent to infringe.

**Visit the Taylor & Francis Web site at**  
**<http://www.taylorandfrancis.com>**

**and the CRC Press Web site at**  
**<http://www.crcpress.com>**

---

# Contents

Preface.....	xiii
Author .....	xv

## **SECTION I** *Design Loads*

<b>Chapter 1</b> Design Criteria .....	3
Classification of Buildings .....	3
Building Codes.....	3
Standard Unit Loads.....	3
Tributary Area.....	3
Working Stress Design, Strength Design, and Unified Design of Structures .....	7
Elastic and Plastic Designs.....	10
Elastic Moment Capacity.....	12
Plastic Moment Capacity.....	12
Combinations of Loads .....	14
Other Loads.....	15
Continuous Load Path for Structural Integrity .....	18
Problems.....	18
<b>Chapter 2</b> Primary Loads: Dead Loads and Live Loads .....	23
Dead Loads.....	23
Live Loads.....	24
Floor Live Loads .....	24
Basic Design Live Load, $L_o$ .....	24
Effective Area Reduction Factor .....	24
Other Provisions for Floor Live Loads.....	26
Multiple Floors Reductions .....	27
Roof Live Loads, $L_r$ .....	28
Tributary Area Reduction Factor, $R_1$ .....	28
Slope Reduction Factor.....	28
Problems.....	29
<b>Chapter 3</b> Snow Loads .....	31
Introduction .....	31
Minimum Snow Load for Low-Slope Roofs .....	31
Balanced Snow Load.....	34
Importance Factor .....	34
Thermal Factor, $C_t$ .....	34
Exposure Factor, $C_e$ .....	35
Roof Slope Factor, $C_s$ .....	35

Rain-on-Snow Surcharge .....	36
Partial Loading of the Balanced Snow Load .....	37
Unbalanced across the Ridge Snow Load .....	38
Snow Drift from a Higher to a Lower Roof .....	40
Leeward Snow Drift on Lower Roof of Attached Structure .....	40
Windward Snow Drift on Lower Roof of Attached Structure .....	41
Leeward Snow Drift on Lower Roof of Separated Structure .....	42
Windward Snow Drift on Lower Roof of Separated Structure .....	42
Sliding Snow Load on Lower Roof .....	44
Sliding Snow Load on Separated Structures .....	46
Problems .....	46
<b>Chapter 4</b> Wind Loads .....	49
Introduction .....	49
Definition of Terms .....	49
Procedures for MWFRS .....	50
Simplified Procedure for MWFRS for Low-Rise Buildings .....	50
Horizontal Pressure Zones for MWFRS .....	57
Vertical Pressure Zones for MWFRS .....	61
Minimum Pressure for MWFRS .....	61
Procedures for Components and Cladding .....	66
Simplified Procedure for Components and Cladding for Low-Rise Buildings .....	66
Minimum Pressures for Components and Cladding .....	70
Problems .....	72
<b>Chapter 5</b> Earthquake Loads .....	75
Seismic Forces .....	75
Seismic Design Procedures .....	75
Definitions .....	76
Structural Height .....	76
Stories above Base and Grade Plane .....	76
Fundamental Period of Structure .....	77
Ground Motion Response Accelerations .....	77
Mapped $MCE_R$ Spectral Response Acceleration Parameters .....	78
Adjustments to Spectral Response Acceleration Parameters for Site Class Effects .....	78
Design Spectral Acceleration Parameters .....	78
Design Response Spectrum .....	78
Importance Factor, $I$ .....	88
Seismic Design Categories .....	88
Exemptions from Seismic Designs .....	90
Equivalent Lateral Force Procedure to Determine Seismic Force .....	90
Effective Weight of Structure, $W$ .....	90
Seismic Response Coefficient, $C_s$ .....	90
Response Modification Factor or Coefficient, $R$ .....	91
Distribution of Seismic Forces .....	92
Distribution of Seismic Forces on Vertical Wall Elements .....	92
Distribution of Seismic Forces on Horizontal Elements (Diaphragms) .....	93



Design Earthquake Load..... 94  
 Soil–Structure Interaction..... 98  
 Problems..... 99

**SECTION II Wood Structures**

**Chapter 6** Wood Specifications..... 105  
 Engineering Properties of Sawn Lumber..... 105  
 Reference Design Values for Sawn Lumber..... 105  
 Adjustments to the Reference Design Values for Sawn Lumber..... 106  
     Time Effect Factor,  $\lambda$ ..... 107  
     Size Factor,  $C_F$ ..... 107  
         Size Factor,  $C_F$ , for Dimension Lumber..... 108  
         Size Factor,  $C_F$ , for Timber..... 108  
     Repetitive Member Factor,  $C_r$ ..... 108  
     Flat Use Factor,  $C_{fu}$ ..... 108  
     Buckling Stiffness Factor,  $C_T$ ..... 108  
     Bearing Area Factor,  $C_b$ ..... 108  
     Format Conversion Factor,  $K_F$ ..... 109  
     Resistance Factor,  $\phi$ ..... 109  
 Load Resistance Factor Design with Wood..... 109  
 Structural Glued Laminated Timber..... 114  
 Reference Design Values for Glued Laminated Timber..... 115  
 Adjustment Factors for Glued Laminated Timber..... 116  
     Flat Use Factor for Glued Laminated Timber,  $C_{FU}$ ..... 116  
     Volume Factor for Glued Laminated Timber,  $C_v$ ..... 116  
     Curvature Factor for Glued Laminated Timber,  $C_c$ ..... 116  
     Stress Interaction Factor,  $C_I$ ..... 118  
     Shear Reduction Factor,  $C_{VR}$ ..... 118  
 Structural Composite Lumber..... 120  
 Summary of Adjustment Factors..... 121  
 Problems..... 123

**Chapter 7** Flexure and Axially Loaded Wood Structures..... 125  
 Introduction..... 125  
 Design of Beams..... 125  
 Bending Criteria of Design..... 125  
 Beam Stability Factor,  $C_L$ ..... 127  
     Effective Unbraced Length..... 128  
 Shear Criteria..... 129  
 Deflection Criteria..... 131  
 Creep Deflection..... 132  
 Bearing at Supports..... 136  
     Bearing Area Factor,  $C_b$ ..... 137  
 Design of Axial Tension Members..... 138  
 Design of Columns..... 140  
 Column Stability Factor,  $C_p$ ..... 141  
 Design for Combined Bending and Compression..... 143  
 Problems..... 147

<b>Chapter 8</b>	Wood Connections .....	153
	Types of Connections and Fasteners .....	153
	Dowel-Type Fasteners (Nails, Screws, Bolts, Pins).....	153
	Yield Limit Theory for Laterally Loaded Fasteners .....	154
	Yield Mechanisms and Yield Limit Equations .....	155
	Reference Design Values for Lateral Loads (Shear Connections) .....	157
	Reference Design Values for Withdrawal Loads .....	157
	Adjustments of the Reference Design Values .....	157
	Wet Service Factor, $C_M$ .....	158
	Temperature Factor, $C_t$ .....	158
	Group Action Factor, $C_g$ .....	158
	Geometry Factor, $C_{\Delta}$ .....	158
	End Grain Factor, $C_{eg}$ .....	161
	Diaphragm Factor, $C_{di}$ .....	161
	Toenail Factor, $C_{tn}$ .....	161
	Nail and Screw Connections .....	164
	Common, Box, and Sinker Nails.....	164
	Post-Frame Ring Shank Nails .....	164
	Wood Screws .....	165
	Bolt and Lag Screw Connections .....	166
	Bolts.....	167
	Lag Screws .....	167
	Problems.....	168

## SECTION III *Steel Structures*

<b>Chapter 9</b>	Tension Steel Members .....	175
	Properties of Steel .....	175
	Provisions to Design Steel Structures .....	175
	Unified Design Specifications .....	176
	Limit States of Design.....	176
	Design of Tension Members.....	177
	Tensile Strength of Elements.....	177
	Net Area, $A_n$ .....	178
	Effective Net Area, $A_e$ .....	179
	Block Shear Strength.....	182
	Design Procedure for Tension Members .....	184
	Problems.....	186
<b>Chapter 10</b>	Compression Steel Members .....	191
	Strength of Compression Members or Columns .....	191
	Local Buckling Criteria.....	193
	Flexural Buckling Criteria .....	194
	Effective Length Factor for Slenderness Ratio .....	194
	Limit States for Compression Design .....	197
	Nonslender Members.....	197
	Flexural Buckling of Nonslender Members in Elastic and Inelastic Regions.....	197

Inelastic Buckling .....	198
Elastic Buckling.....	198
Torsional and Flexural–Torsional Buckling of Nonslender Members .....	198
Single-Angle Members.....	200
Built-Up Members.....	200
Slender Compression Members.....	200
Use of the Compression Tables .....	200
Problems.....	203
<b>Chapter 11 Flexural Steel Members .....</b>	<b>209</b>
Basis of Design.....	209
Nominal Strength of Steel in Flexure .....	209
Lateral Unsupported Length .....	209
Fully Plastic Zone with Adequate Lateral Support.....	211
Inelastic Lateral Torsional Buckling Zone.....	211
Modification Factor $C_b$ .....	211
Elastic Lateral Torsional Buckling Zone.....	212
Noncompact and Slender Beam Sections for Flexure.....	212
Compact Full Plastic Limit .....	213
Noncompact Flange Local Buckling.....	213
Slender Flange Local Buckling.....	214
Summary of Beam Relations .....	214
Design Aids.....	215
Shear Strength of Steel.....	218
Beam Deflection Limitations .....	220
Problems.....	222
<b>Chapter 12 Combined Forces on Steel Members.....</b>	<b>225</b>
Design Approach to Combined Forces .....	225
Combination of Tensile and Flexure Forces.....	225
Combination of Compression and Flexure Forces: The Beam-Column Members .....	227
Members without Sidesway.....	227
Members with Sidesway .....	227
Magnification Factor $B_1$ .....	229
Moment Modification Factor, $C_M$ .....	229
K Values for Braced Frames.....	231
Braced Frame Design.....	231
Magnification Factor for Sway, $B_2$ .....	235
K Values for Unbraced Frames .....	235
Unbraced Frame Design.....	237
Open-Web Steel Joists .....	240
Joist Girders.....	243
Problems.....	245
<b>Chapter 13 Steel Connections .....</b>	<b>251</b>
Types of Connections and Joints .....	251
Bolted Connections .....	251

Specifications for Spacing of Bolts and Edge Distance .....	254
Bearing-Type Connections .....	255
Slip-Critical Connections .....	259
Tensile Load on Bolts .....	261
Combined Shear and Tensile Forces on Bolts .....	263
Combined Shear and Tension on Bearing-Type Connections .....	263
Combined Shear and Tension on Slip-Critical Connections .....	265
Welded Connections .....	267
Groove Welds .....	267
Effective Area of Groove Weld .....	267
Fillet Welds .....	267
Effective Area of Fillet Weld .....	267
Minimum Size of Fillet Weld .....	267
Maximum Size of Fillet Weld .....	268
Length of Fillet Weld .....	268
Strength of Weld .....	268
Complete Joint Penetration Groove Welds .....	268
Partial Joint Penetration Welds and Fillet Welds .....	268
Frame Connections .....	271
Shear or Simple Connection for Frames .....	272
Single-Plate Shear Connection or Shear Tab .....	272
Framed-Beam Connection .....	272
Seated-Beam Connection .....	272
End-Plate Connection .....	272
Single-Plate Shear Connection for Frames .....	274
Moment-Resisting Connection for Frames .....	277
Problems .....	279

## **SECTION IV Reinforced Concrete Structures**

<b>Chapter 14</b> Flexural Reinforced Concrete Members .....	289
Properties of Reinforced Concrete .....	289
Compression Strength of Concrete .....	289
Design Strength of Concrete .....	290
Strength of Reinforcing Steel .....	291
Load Resistance Factor Design Basis of Concrete .....	291
Reinforced Concrete Beams .....	292
Derivation of the Beam Relations .....	292
Strain Diagram and Modes of Failure .....	294
Balanced and Recommended Steel Percentages .....	295
Minimum Percentage of Steel .....	295
Strength Reduction Factor for Concrete .....	296
Specifications for Beams .....	296
Analysis of Beams .....	297
Design of Beams .....	299
Design for Reinforcement Only .....	299
Design of Beam Section and Reinforcement .....	300

One-Way Slab.....	303
Specifications for Slabs .....	303
Analysis of One-Way Slab.....	304
Design of One-Way Slab .....	305
Problems.....	306
<b>Chapter 15</b> Doubly and T Reinforced Concrete Beams.....	311
Doubly Reinforced Concrete Beams.....	311
Analysis of Doubly Reinforced Beams.....	313
Design of Doubly Reinforced Beams.....	316
Monolithic Slab and Beam (T Beams).....	317
Analysis of T Beams .....	318
Design of T Beams.....	320
Problems.....	323
<b>Chapter 16</b> Shear and Torsion in Reinforced Concrete .....	327
Stress Distribution in Beam .....	327
Diagonal Cracking of Concrete.....	329
Strength of Web (Shear) Reinforced Beam.....	329
Shear Contribution of Concrete.....	331
Shear Contribution of Web Reinforcement.....	331
Specifications for Web (Shear) Reinforcement .....	332
Analysis for Shear Capacity.....	333
Design for Shear Capacity.....	335
Torsion in Concrete .....	338
Provision for Torsional Reinforcement.....	339
Problems.....	341
<b>Chapter 17</b> Compression and Combined Forces Reinforced Concrete Members .....	347
Types of Columns.....	347
Pedestals .....	347
Columns with Axial Loads.....	347
Short Columns with Combined Loads .....	347
Large or Slender Columns with Combined Loads .....	347
Axially Loaded Columns .....	348
Strength of Spirals.....	349
Specifications for Columns .....	350
Analysis of Axially Loaded Columns.....	351
Design of Axially Loaded Columns.....	353
Short Columns with Combined Loads.....	355
Effects of Moment on Short Columns.....	357
Only Axial Load Acting.....	357
Large Axial Load and Small Moment (Small Eccentricity) .....	357
Large Axial Load and Moment Larger than Case 2 Section .....	358
Large Axial Load and Moment Larger than Case 3 Section .....	358
Balanced Axial Load and Moment .....	358

Small Axial Load and Large Moment..... 359  
No Appreciable Axial Load and Large Moment..... 359  
Characteristics of the Interaction Diagram ..... 359  
Application of the Interaction Diagram ..... 361  
Analysis of Short Columns for Combined Loading..... 361  
Design of Short Columns for Combined Loading ..... 362  
Long or Slender Columns..... 364  
Problems ..... 364

**Bibliography** ..... 369

**Appendix A** ..... 371

**Appendix B** ..... 377

**Appendix C** ..... 431

**Appendix D** ..... 483

---

# Preface

This book intends to meet the need that exists for an elementary level textbook in structural design. It is a complete book. The book has a code-connected focus. Since publication of the first edition in 2010, all codes and standards have undergone revisions. The *International Building Codes* and the *International Residential Codes* were updated in 2012. The American Society of Civil Engineers (ASCE) has revised the *Minimum Design Loads for Buildings and Other Structures* to ASCE 7-10. The American Wood Council has published *National Design Specifications* (NDS) 2012 for wood design. The American Institute of Steel Construction (AISC) has updated the *Steel Construction Manual* and the *Seismic Design Manual* to 2010 *Standards and Specifications*. The American Concrete Institute (ACI) has come up with new ACI 380-2011 *Building Code Requirements for Structural Concrete*.

All these changes have necessitated an accelerated revision of the book. While undertaking this task, the text material has been thoroughly reviewed and expanded, including inclusion of a new chapter on concrete design.

The book retains its original feature; it is suitable for a combined design coursework in wood, steel, and concrete. It is a self-contained book that includes all essential material—the section properties, design values, reference tables, and other design aids required to accomplish complete structural designs according to the codes. Unlike other books, the requirements of the separate documents pertaining to the codes and standards of the issuing agencies are not a prerequisite with this book.

The book is appropriate for an academic program in architecture, construction management, general engineering, and civil engineering, where the curriculum provides for a joint coursework in wood, steel, and concrete design.

The book has four sections, expanded into 17 chapters. Section I, comprising Chapters 1 through 5, enables students to determine the various types and magnitude of loads that will be acting on any structural element and the combination(s) of those loads that will control the design. ASCE 7-10 has made major revisions to the provisions for wind loads. In Section I, the philosophy of the load and resistance factor design and the unified approach to design are explained.

Wood design in Section II from Chapters 6 through 8 covers sawn lumber, glued laminated timber, and structural composite or veneer lumber, which are finding increased application in wood structures. The NDS 2012 has modified the format conversion factors and has also introduced some new modification factors. First, the strength capacities in accordance with the NDS 2012 for tensile, compression, and bending members are discussed and the basic designs of these members are performed. Subsequently, the designs of columns, beams, and combined force members are presented, incorporating the column stability and beam stability and other factors. The connection is an important subject because it is often neglected and proves to be a weak link of a structure. The dowel-type connections (nails, screws, and bolts) have been presented in detail, together with the complete set of tables of the reference design values.

Section III from Chapters 9 through 13 deals with steel structures. This covers the designs of tensile, compression, bending members and the braced and unbraced frames according to the AISC specifications and the designs of open-web steel joists and joist girders according to the standards of the Steel Joists Institute. AISC 2010 has made some revisions to the sectional properties of certain structural elements. It has also made changes in the procedure to design the slip-critical connection. Similar to wood design, a separate chapter considers shear connection, tension connection, and moment-resisting bolted and welded connections and various types of frame connections.

Section IV from Chapters 14 through 17 covers the reinforced concrete design. A new chapter on T beams and doubly reinforced beams has been added. In concrete, there is no tensile member and shear is handled differently as discussed in Chapter 16.

My wife Saroj Gupta helped in typing and editing of the manuscript. In the first edition, senior students from my structural design class also made valuable contributions; Ignacio Alvarez had prepared revised illustrations, and Andrew Dahlman, Ryan Goodwin, and George Schork had reviewed the end-of-chapter problems. In this edition, senior students, Michael Santerre and Raphael DeLassus, reviewed the solutions to the problems relating to Section III and Section IV, respectively. Joseph Clements, David Fausel, and other staff members at CRC Press provided valuable support that led to the completion of the revised edition. During proofs review and edit phase, very prompt responses and necessary help came from Dhayanidhi Karunanidhi and Paul Abraham Isaac of diacriTech. I offer my sincere thanks to all and to my colleagues at Roger Williams University who extended a helping hand from time to time.

**Ram S. Gupta**  
*Roger Williams University*



---

# Author

**Ram S. Gupta** earned a master's in engineering from the Indian Institute of Technology (IIT), Roorkee, India, and a PhD from Polytechnic University, New York. He is a registered professional engineer in Rhode Island and Massachusetts.

Dr. Gupta has 40 years of experience working on projects in the United States, Australia, India, and Liberia (West Africa) and is currently working as a professor of engineering at Roger Williams University (RWU), Bristol, Rhode Island. He has been a full-time faculty member at RWU since 1981. He was a rotary scholar professor at Kathmandu University, Dhulikhel, Nepal, and a Fulbright scholar at the IIT, Kanpur, India.

Dr. Gupta is president of Delta Engineers Inc., a Rhode Island-based consulting company, specializing in structural and water resource disciplines.

Besides contributing to a very large number of research papers, Dr. Gupta has authored three very successful books: *Hydrology and Hydraulic Systems*, 3rd edition (Waveland Press, Long Grove, IL, 2008), *Introduction to Environmental Engineering and Science*, 2nd edition (ABS Consulting, Rockville, MD, 2004), and *Principles of Structural Design: Wood, Steel, and Concrete* (Taylor & Francis Group, Boca Raton, FL, 2010).



# *Section I*

---

## *Design Loads*



---

# 1 Design Criteria

## CLASSIFICATION OF BUILDINGS

Buildings and other structures are classified based on the risk associated with unacceptable performance of the structure, according to Table 1.1. The risk categories range from I to IV, where category I represents buildings and other structures that pose no danger to human life in the event of failure and category IV represents all essential facilities. Each structure is assigned the highest applicable risk category. Assignment of more than one risk category to the same structure based on use and loading conditions is permitted.

## BUILDING CODES

To safeguard public safety and welfare, towns and cities across the United States follow certain codes for design and construction of buildings and other structures. Until recently, towns and cities modeled their codes based on the following three regional codes, which are normally revised at 3-year intervals:

1. The Building Officials and Code Administrators National Building Code
2. The Uniform Building Code
3. The Standard Building Code

The International Codes Council was created in 1994 for the purpose of unifying these codes into a single set of standards. The council included representatives from the three regional code organizations. The end result was the preparation of the *International Building Code (IBC)*, which was first published in 2000, with a second revision in 2003 and a third revision in 2006. The latest is the fifth edition of 2012. Now, practically all local and state authorities follow the IBC. For the specifications of loads to which structures should be designed, the IBC makes a direct reference to the American Society of Civil Engineers' publication *Minimum Design Loads for Buildings and Other Structures*, which is commonly referred to as the *American Society of Civil Engineers (ASCE) 7-10*.

## STANDARD UNIT LOADS

The primary loads on a structure are dead loads due to the weight of structural components and live loads due to structural occupancy and usage. The other common loads are snow loads, wind loads, and seismic loads. Some specific loads to which a structure could additionally be subjected to comprise soil loads, hydrostatic forces, flood loads, rain loads, and ice loads (atmospheric icing). ASCE 7-10 specifies the standard unit loads that should be adopted for each category of loading. These have been described in Chapters 2 through 5 for the main categories of loads.

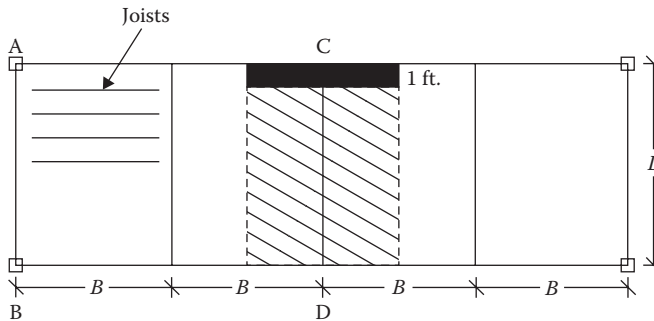
## TRIBUTARY AREA

Since the standard unit load in the ASCE 7-10 is for a unit area, it needs to be multiplied by the effective area of the structural element on which it acts to ascertain the total load. In certain cases, the ASCE 7-10 specifies the concentrated load; then, its location needs to be considered for

**TABLE 1.1**  
**Risk Category of Buildings and Other Structures**

Nature of Occupancy	Category
Agriculture, temporary structures, storage	I
All buildings and structures except those classified as I, III, and IV	II
Buildings and other structures that can cause a substantial economic impact and/or mass disruption of day-to-day civil lives, including the following:	III
More than 300 people congregation	
Day care with more than 150	
School with more than 250 and college with more than 500	
Resident health care with 50 or more	
Jail	
Power generation, water treatment, wastewater treatment, telecommunication centers	
Essential facilities, including the following:	IV
Hospitals	
Fire, police, ambulance	
Emergency shelters	
Facilities needed in emergency	

Source: Courtesy of American Society of Civil Engineers, Reston, Virginia.



**FIGURE 1.1** Parallel framing system.

maximum effect. In the parallel framing system shown in Figure 1.1, the beam CD receives the load from the floor that extends halfway to the next beam ( $B/2$ ) on each side, as shown by the hatched area. Thus, the tributary area of the beam is  $B \times L$  and the load is  $W = w \times B \times L$ , where  $w$  is the unit standard load. The exterior beam AB receives the load from one side only extending halfway to the next beam. Hence, the tributary area is  $\frac{1}{2}B \times L$ .

Suppose we consider a strip of 1 ft. width, as shown in Figure 1.1. The area of the strip is  $1 \times B$ . The load of the strip is  $w \times B$ , which represents the uniform load per running foot (or meter) of the beam.

The girder is point loaded at the locations of beams by beam reactions. However, if the beams are closely spaced, the girder could be considered to bear a uniform load from the tributary area of  $\frac{1}{2}B \times L$ .

In Figure 1.2, beam AB supports a rectangular load from an area A, B, 2, 1; the area is  $BL/2$  and the load is  $wBL/2$ . It also supports a triangular load from an area A, B, 3; this area is  $(\frac{1}{2})BL/2$  and the load is  $wBL/4$ . This has a distribution as shown in Figure 1.3.

Beam AC supports the triangular load from area A, C, 3, which is  $wBL/4$ . However, the loading on the beam is not straightforward because the length of the beam is not  $L$  but  $L_1 = (\sqrt{L^2 + B^2})$

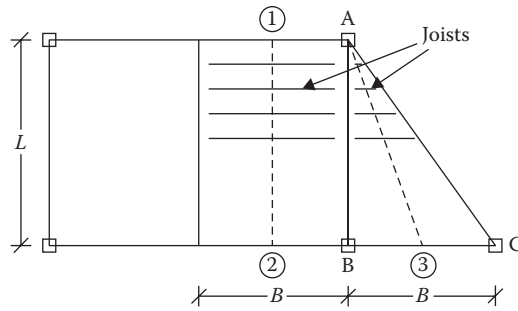


FIGURE 1.2 A triangular framed system.

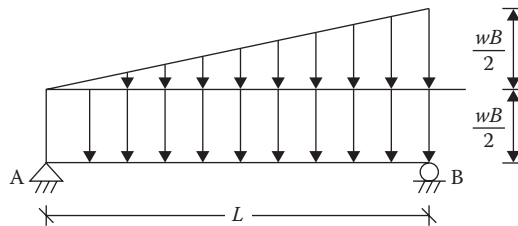


FIGURE 1.3 Load distribution on beam AB of Figure 1.2.

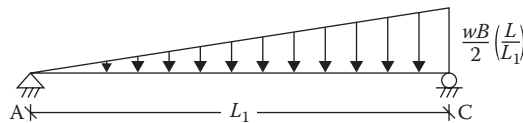


FIGURE 1.4 Load distribution on beam AC of Figure 1.2.

(Figure 1.4). The triangular loading is as shown in Figure 1.4 to represent the total load (the area under the load diagram) of  $wBL/4$ .

The framing of a floor system can be arranged in more than one manner. The tributary area and the loading pattern on the framing elements will be different for different framing systems, as shown in Figures 1.5 and 1.6.

### Example 1.1

In Figure 1.2, the span  $L$  is 30 ft. and the spacing  $B$  is 10 ft. The distributed standard unit load on the floor is 60 lb/ft.<sup>2</sup> Determine the tributary area, and show the loading on beams AB and AC.

### SOLUTION

Beam AB:

1. Rectangular tributary area per foot of beam length =  $1 \times 5 = 5 \text{ ft.}^2/\text{ft.}$
2. Uniform load per foot = (standard unit load  $\times$  tributary area) =  $(60 \text{ lb/ft.}^2)(5 \text{ ft.}^2/\text{ft.}) = 300 \text{ lb/ft.}$
3. Triangular tributary area (total) =  $\frac{1}{2}(5)(30) = 75 \text{ ft.}^2$
4. Total load of triangular area =  $60 \times 75 = 4500 \text{ lb.}$
5. For load at the end of  $w$  per foot, area of triangular load diagram =  $\frac{1}{2}wL$ .
6. Equating items (4) and (5),  $\frac{1}{2}wL = 4500$  or  $w = 300 \text{ lb/ft.}$
7. Loading is shown in Figure 1.7.

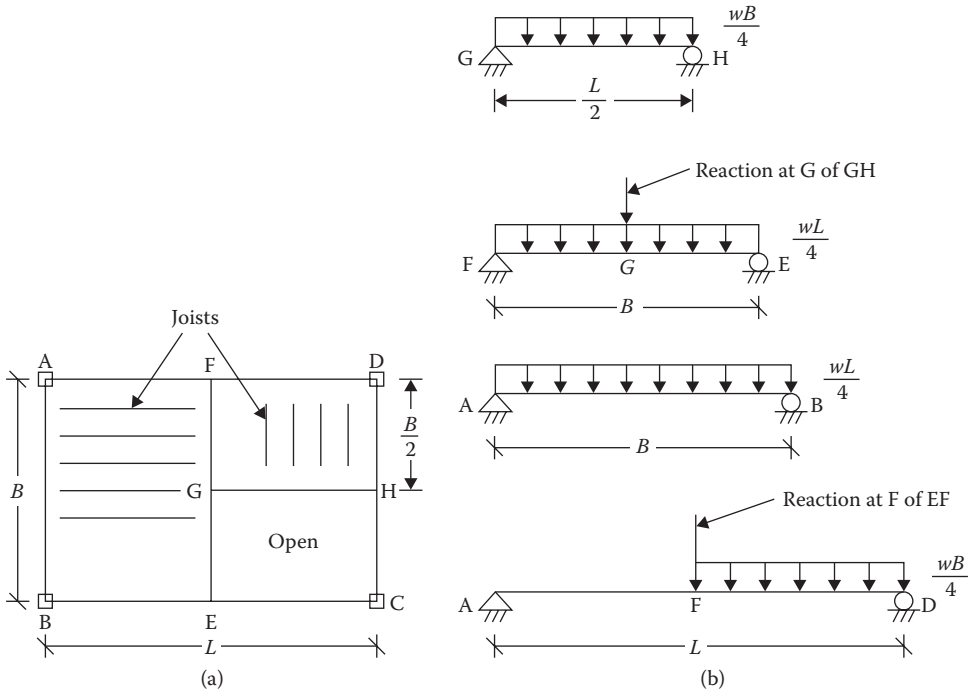


FIGURE 1.5 (a) A framing arrangement. (b) Distribution of loads on elements of frame in Figure 1.5a.

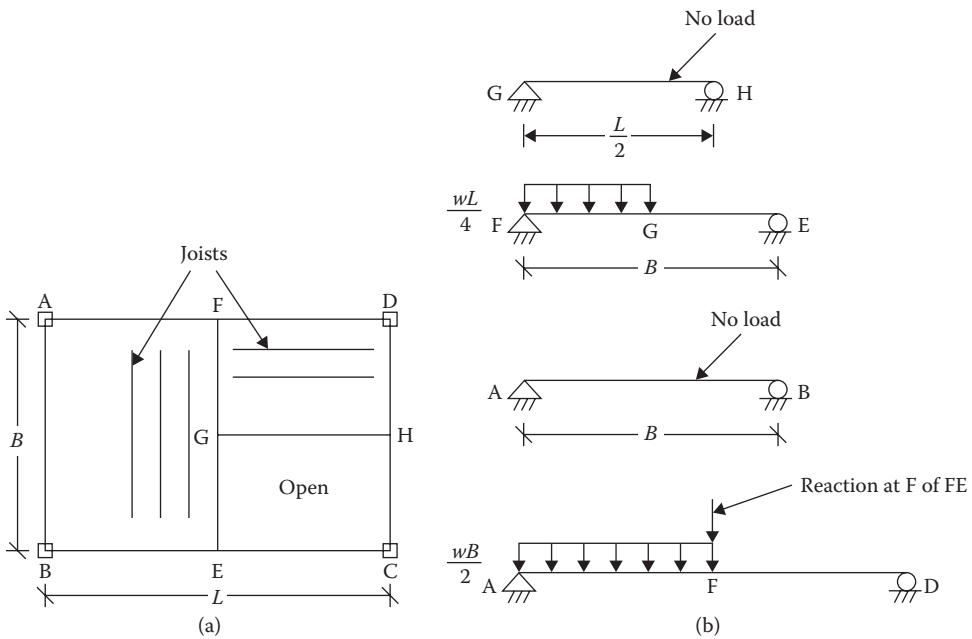


FIGURE 1.6 (a) An alternative framing arrangement. (b) Distribution of loads on elements of frame in Figure 1.6a.



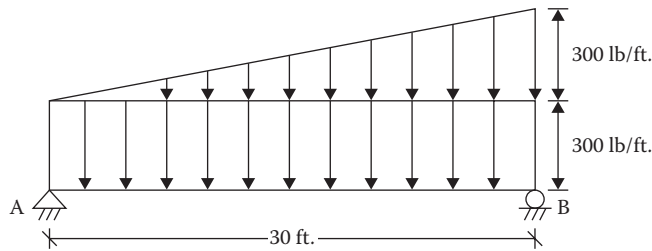


FIGURE 1.7 Distribution of loads on beam AB of Example 1.1.

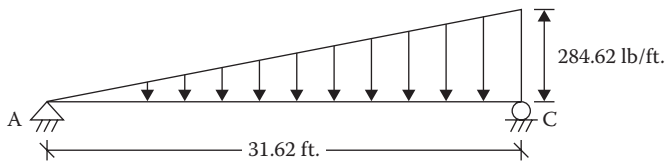


FIGURE 1.8 Distribution of loads on beam AC of Example 1.1.

Beam AC:

1. Tributary area = 75 ft.<sup>2</sup>
2. Total load = 60 × 75 = 4500 lb.
3. Length of beam AC,  $L = (\sqrt{30^2 + 10^2}) = 31.62$  ft.
4. Area of triangular load diagram =  $\frac{1}{2}wL = \frac{1}{2}w(31.62)$ .
5. Equating (2) and (4),  $\frac{1}{2}w(31.62) = 4500$  or  $w = 284.62$  lb/ft.
6. The loading is shown in Figure 1.8.

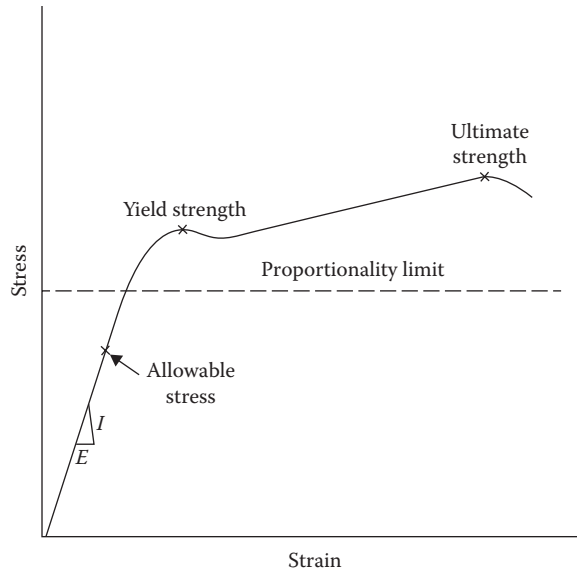
## WORKING STRESS DESIGN, STRENGTH DESIGN, AND UNIFIED DESIGN OF STRUCTURES

There are two approaches to design: (1) the traditional approach and (2) a comparatively newer approach. The distinction between them can be understood from the stress–strain diagram. The stress–strain diagram with labels for a ductile material is shown in Figure 1.9. The diagram for a brittle material is similar except that there is only one hump indicating both the yield and the ultimate strength point and the graph at the beginning is not really (but close to) a straight line.

Allowable stress is ultimate strength divided by a factor of safety. It falls on the straight-line portion within the elastic range. In the allowable stress design (ASD) or working stress design method, the design is carried out so that when the computed design load, known as the *service load*, is applied on a structure, the actual stress created does not exceed the allowable stress limit. Since the allowable stress is well within the ultimate strength, the structure is safe. This method is also known as the *elastic design approach*.

In the other method, known variously as *strength design*, *limit design*, or *load resistance factor design* (LRFD), the design is carried out at the ultimate strength level. Since we do not want the structure to fail, the design load value is magnified by a certain factor known as the *load factor*. Since the structure at the ultimate level is designed for loads higher than actual loads, it does not fail. In strength design, the strength of the material is taken to be the ultimate strength, and a resistance factor ( $<1$ ) is applied to the ultimate strength to account for uncertainties associated with determining the ultimate strength.

The LRFD method is more efficient than the ASD method. In the ASD method, a single factor of safety is applied to arrive at the design stress level. In LRFD, different load factors are applied depending on the reliability to which the different loads can be computed. Moreover, resistance factors are applied to account for the uncertainties associated with the strength values.



**FIGURE 1.9** Stress–strain relation of a ductile material.

The American Concrete Institute was the first regulatory agency to adopt the (ultimate) strength design approach in early 1970 because concrete does not behave as an elastic material and does not display the linear stress–strain relationship at any stage. The American Institute of Steel Construction (AISC) adopted the LRFD specifications in the beginning of 1990. On the other hand, the American Forest and Paper Association included the LRFD provisions only recently, in the 2005 edition of the *National Design Specification for Wood Construction*.

The *AISC Manual 2005* proposed a unified approach wherein it had combined the ASD and the LRFD methods together in a single documentation. The principle of unification is as follows.

The nominal strength of a material is a basic quantity that corresponds to its ultimate strength. In terms of force, the nominal (force) strength is equal to yield or ultimate strength (stress) times the sectional area of a member. In terms of moment, the nominal (moment) strength is equal to ultimate strength times the section modulus of the member. Thus,

$$P_n = F_y A \quad (1.1)$$

$$M_n = F_y S \quad (1.2)$$

where

$A$  is area of cross section

$S$  is section modulus

In the ASD approach, the nominal strength of a material is divided by a factor of safety to convert it to the allowable strength. Thus,

$$\text{Allowable (force) strength} = \frac{P_n}{\Omega} \quad (1.3)$$

$$\text{Allowable (moment) strength} = \frac{M_n}{\Omega} \quad (1.4)$$

where  $\Omega$  is factor of safety.

For a safe design, the load or moment applied on the member should not exceed the allowable strength. Thus, the basis of the ASD design is as follows:

$$P_a \leq \frac{P_n}{\Omega} \quad (1.5)$$

and

$$M_a \leq \frac{M_n}{\Omega} \quad (1.6)$$

where

$P_a$  is service design load combination

$M_a$  is moment due to service design load application

Using Equation 1.5 or 1.6, the required cross-sectional area or the section modulus of the member can be determined.

The common ASD procedure works at the stress level. The service (applied) load,  $P_a$ , is divided by the sectional area,  $A$ , or the service moment,  $M$ , is divided by the section modulus,  $S$ , to obtain the applied or created stress due to the loading,  $\sigma_a$ . Thus, the cross-sectional area and the section modulus are not used on the strength side but on the load side in the usual procedure. It is the ultimate or yield strength (stress) that is divided by the factor of safety to obtain the permissible stress,  $\sigma_p$ . To safeguard the design, it is ensured that the applied stress,  $\sigma_a$ , does not exceed the permissible stress,  $\sigma_p$ .

For the purpose of unification of the ASD and LRFD approaches, the aforementioned procedure considers strength in terms of the force or the moment. In the LRFD approach, the nominal strengths are the same as given by Equations 1.1 and 1.2. The design strengths are given by

$$\text{Design (force) strength} = \phi P_n \quad (1.7)$$

$$\text{Design (moment) strength} = \phi M_n \quad (1.8)$$

where  $\phi$  is resistance factor.

The basis of design is

$$P_u \leq \phi P_n \quad (1.9)$$

$$M_u \leq \phi M_n \quad (1.10)$$

where

$P_u$  is factored design loads

$M_u$  is maximum moment due to factored design loads

From the aforementioned relations, the required area or the section modulus can be determined, which are the parts of  $P_n$  and  $M_n$  in Equations 1.1 and 1.2.

A link between the ASD and the LRFD approaches can be made as follows: from Equation 1.5 for ASD, at the upper limit

$$P_n = \Omega P_a \quad (1.11)$$

Considering only the dead load and the live load,  $P_a = D + L$ . Thus,

$$P_n = \Omega(D + L) \quad (1.12)$$

**TABLE 1.2**  
 **$\Omega$  As a Function of  $\phi$  for Various  $L/D$  Ratios**

$L/D$ Ratio (Select)	$\Omega$ From Equation 1.16
1	$1.4/\phi$
2	$1.47/\phi$
3	$1.5/\phi$
4	$1.52/\phi$

From the Equation 1.9 for LFRD, at the upper limit

$$P_n = \frac{P_u}{\phi} \quad (1.13)$$

Considering only the factored dead load and live load,  $P_u = 1.2D + 1.6L$ . Thus,

$$P_n = \frac{(1.2D + 1.6L)}{\phi} \quad (1.14)$$

Equating Equations 1.12 and 1.14,

$$\frac{(1.2D + 1.6L)}{\phi} = \Omega(D + L) \quad (1.15)$$

or

$$\Omega = \frac{1(1.2D + 1.6L)}{\phi(D + L)} \quad (1.16)$$

The factor of safety,  $\Omega$ , has been computed as a function of the resistance factor,  $\phi$ , for various selected live-to-dead load ratios in Table 1.2.

The 2005 AISC specifications used the relation  $\Omega = 1.5/\phi$  throughout the manual to connect the ASD and LRFD approaches. Wood and concrete structures are relatively heavier, that is, the  $L/D$  ratio is less than 3 and the factor of safety,  $\Omega$ , tends to be lower than  $1.5/\phi$ , but a value of 1.5 could reasonably be used for these structures as well because the variation of the factor is not significant. This book uses the LRFD basis of design for all structures.

## ELASTIC AND PLASTIC DESIGNS

The underlying concept in the preceding section is that a limiting state is reached when the stress level at any point in a member approaches the yield strength value of the material and the corresponding load is the design capacity of the member.

Let us revisit the stress–strain diagram for a ductile material like steel. The initial portion of the stress–strain curve of Figure 1.9 has been drawn again in Figure 1.10 to a greatly enlarged horizontal scale. The yield point  $F_y$  is a very important property of structural steel. After an initial yield, a steel element elongates in the plastic range without any appreciable change in stress level. This elongation is a measure of ductility and serves a useful purpose in steel design. The strain and stress diagrams for a rectangular beam due to increasing loading are shown in Figures 1.11 and 1.12.

Beyond the yield strain at point b, as a load increases the strain continues to rise in the plastic range and the stress at yield level extends from the outer fibers into the section. At point d, the entire section has achieved the yield stress level and no more stress capacity is available to develop. This is known as the *fully plastic state* and the moment capacity at this state as the *full plastic moment*.

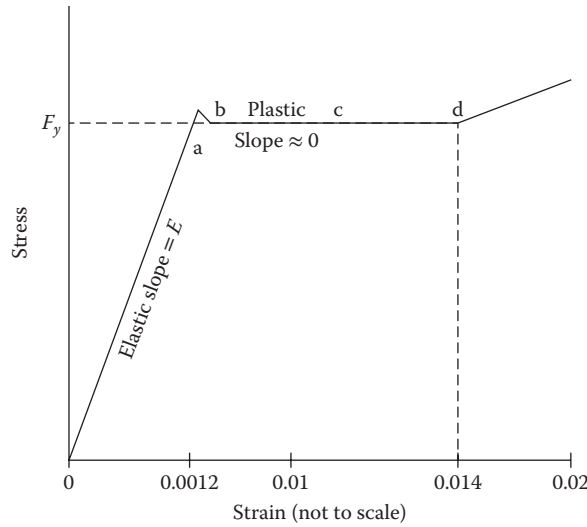


FIGURE 1.10 Initial portion of stress–strain relation of a ductile material.

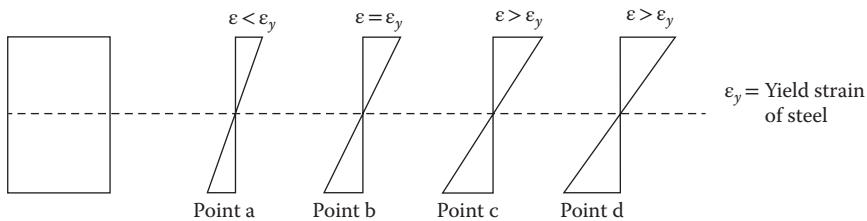


FIGURE 1.11 Strain variation in a rectangular section.

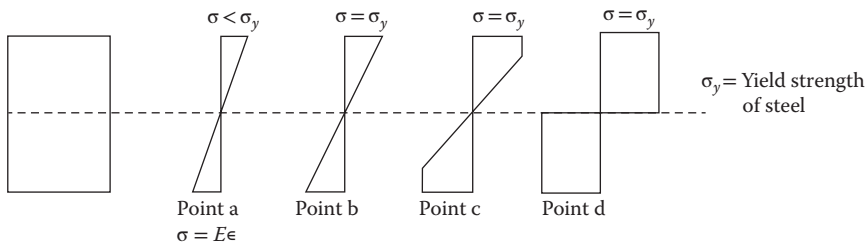


FIGURE 1.12 Stress variation in a rectangular section.

The full moment is the ultimate capacity of a section. Beyond this, a structure will collapse. When full moment capacity is reached, we say that a *plastic hinge* has formed. In a statically determinate structure, the formation of one plastic hinge will lead to a collapse mechanism. Two or more plastic hinges are required in a statically indeterminate structure for a collapse mechanism. In general, for a complete collapse mechanism,

$$n = r + 1 \tag{1.17}$$

where

- $n$  is number of plastic hinges
- $r$  is degree of indeterminacy

**ELASTIC MOMENT CAPACITY**

As stated earlier, structures are commonly designed for elastic moment capacity, that is, the failure load is based on the stress reaching a yield level at any point. Consider that on the rectangular beam of width  $b$  and depth  $d$  of Figure 1.10 at position b when the strain has reached the yield level, a full elastic moment,  $M_E$ , acts. This is shown in Figure 1.13.

Total compression force is as follows:

$$C = \frac{1}{2} \sigma_y A_c = \frac{1}{2} \sigma_y \frac{bd}{2} \tag{a}$$

Total tensile force is as follows:

$$T = \frac{1}{2} \sigma_y A_t = \frac{1}{2} \sigma_y \frac{bd}{2} \tag{b}$$

These act at the centroids of the stress diagram in Figure 1.13.

$$M_E = \text{force} \times \text{moment arm}$$

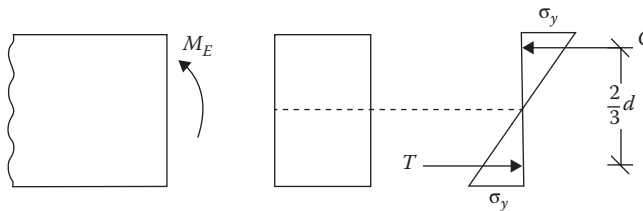
$$M_E = \left( \frac{1\sigma_y}{2} \frac{bd}{2} \right) \times \left( \frac{2d}{3} \right) \tag{c}$$

$$M_E = \sigma_y \frac{bd^2}{6} \tag{1.18}$$

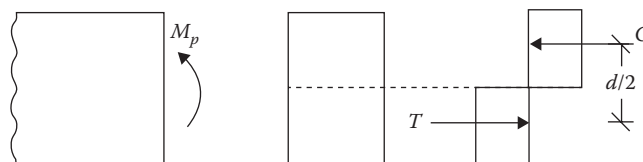
It should be noted that  $bd^2/6 = S$ , the section modulus, and the aforementioned relation is given by  $M = \sigma_y S$ . In terms of moment of inertia, this relation is  $M = \sigma_y I/c$ . In the case of a nonsymmetrical section, the neutral axis is not in the center and there are two different values of  $c$  and, accordingly, two different section moduli. The smaller  $M_E$  is used for the moment capacity.

**PLASTIC MOMENT CAPACITY**

Consider a full plastic moment,  $M_p$ , acting on the rectangular beam section at the stress level  $d$  of Figure 1.10. This is shown in Figure 1.14.



**FIGURE 1.13** Full elastic moment acting on a rectangular section.



**FIGURE 1.14** Full plastic moment acting on a rectangular section.

Total compression force is as follows:

$$C = \sigma_y A_c = \sigma_y \frac{bd}{2} \quad (a)$$

Total tensile force is as follows:

$$T = \sigma_y A_t = \sigma_y \frac{bd}{2} \quad (b)$$

$$M_p = \text{force} \times \text{moment arm}$$

$$= \sigma_y \frac{bd}{2} \times \frac{d}{2} \quad (c)$$

or

$$M_p = \sigma_y \frac{bd^2}{4} \quad (1.19)$$

This is given by

$$M_p = \sigma_y Z \quad (1.20)$$

where  $Z$  is called the *plastic section modulus*. For a rectangle, the *plastic section modulus* is 1.5 times the (elastic) section modulus and the plastic moment capacity ( $M_p$ ) is 1.5 times the elastic moment capacity ( $M_E$ ). The ratio between the full plastic and the full elastic moment of a section is called the *shape factor*. In other words, for the same design moment value the section is smaller according to the plastic design.

The plastic analysis is based on the collapse load mechanism and requires knowledge of how a structure behaves when stress exceeds the elastic limit. The plastic principles are used in the design of steel structures.

### Example 1.2

For the steel beam section shown in Figure 1.15, determine the (a) elastic moment capacity, (b) plastic moment capacity, and (c) shape factor. The yield strength is 210 MPa.

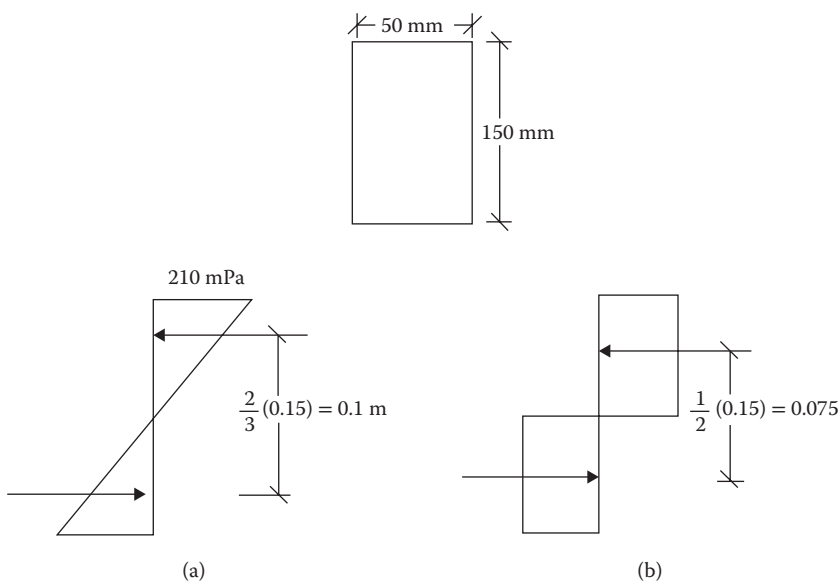


FIGURE 1.15 (a) Elastic moment capacity of beam section. (b) Plastic moment capacity of beam section.

**SOLUTION**

a. Elastic moment capacity

1. Refer to Figure 1.15a

$$2. C = T = \frac{1}{2}(210 \times 10^6)(0.05 \times 0.075) = 393.75 \times 10^3 \text{ N}$$

$$3. M_E = (393.75 \times 10^3) \times 0.1 = 39.38 \times 10^3 \text{ N}\cdot\text{m}$$

b. Plastic moment capacity

1. Refer to Figure 1.15b

$$2. C = T = (210 \times 10^6)(0.05 \times 0.075) = 787.5 \times 10^3 \text{ N}$$

$$3. M_p = (787.5 \times 10^3) \times 0.075 = 59.06 \times 10^3 \text{ N}\cdot\text{m}$$

c. Shape factor

$$\text{SF} = \frac{M_p}{M_E} = \frac{59.06 \times 10^3}{39.38 \times 10^3} = 1.5$$

**Example 1.3**

The design moment for a rectangular beam is 40 kN·m. The yield strength of the material is 200 MPa. Design a section having a width–depth ratio of 0.5 according to the (a) elastic theory and (b) plastic theory.

**SOLUTION**

a. Elastic theory

$$1. M_E = \sigma_y S$$

or

$$S = \frac{M_E}{\sigma_y} = \frac{40 \times 10^3}{200 \times 10^6} = 0.2 \times 10^{-3} \text{ m}^3$$

$$2. \frac{1}{6}bd^2 = 0.2 \times 10^{-3}$$

$$\frac{1}{6}(0.5d)(d^2) = 0.2 \times 10^{-3}$$

or

$$d = 0.134 \text{ m}$$

and

$$b = 0.076 \text{ m}$$

b. Plastic theory

$$1. M_p = \sigma_y Z$$

or

$$Z = \frac{M_p}{\sigma_y} = \frac{40 \times 10^3}{200 \times 10^6} = 0.2 \times 10^{-3} \text{ m}^3$$

$$2. \frac{1}{4}bd^2 = 0.2 \times 10^{-3} \text{ m}^3$$

$$\frac{1}{4}(0.5d)(d^2) = 0.2 \times 10^{-3} \text{ m}^3$$

or

$$d = 0.117 \text{ m}$$

and

$$b = 0.058 \text{ m}$$

**COMBINATIONS OF LOADS**

Various types of loads that act on a structure are described in the “Standard Unit Loads” section. For designing a structure, its elements, or its foundation, loads are considered to act in the following combinations with load factors as indicated in order to produce the most unfavorable effect on the



structure or its elements. Dead load, roof live load, floor live load, and snow load are gravity loads that act vertically downward. Wind load and seismic load have vertical as well as lateral components. The vertically acting roof live load, live load, wind load (simplified approach), and snow load are considered to be acting on the horizontal projection of any inclined surface. However, dead load and the vertical component of earthquake load act over the entire inclined length of the member.

For LRFD, ASCE 7-10 recommends the following seven combinations with respect to common types of loads. In ASCE 7-10, the factor for wind load has been changed to 1 (strength level) from an earlier factor of 1.6. The wind speed maps have been changed accordingly:

$$1. 1.4D \quad (1.21)$$

$$2. 1.2D + 1.6L + 0.5(L_r \text{ or } S) \quad (1.22)$$

$$3. 1.2D + 1.6(L_r \text{ or } S) + fL \text{ or } 0.5W \quad (1.23)$$

$$4. 1.2D + 1.0W + fL + 0.5(L_r \text{ or } S) \quad (1.24)$$

$$5. 1.2D + E_v + E_h + fL + 0.2S \quad (1.25)$$

$$6. 0.9D + 1.0W \quad (1.26)$$

$$7. 0.9D - E_v + E_h \quad (1.27)$$

where

$D$  is dead load

$L$  is live load

$L_r$  is roof live load

$S$  is snow load

$W$  is wind load

$E_h$  is horizontal earthquake load

$E_v$  is vertical earthquake load

$f = 0.5$  for all occupancies when the unit live load does not exceed 100 psf except for garage and public assembly and  $f = 1$  when unit live load is 100 psf or more and for any load on garage and public places

## OTHER LOADS

1. When a fluid load,  $F$ , is present, it should be included with the live load (the same factor) in combinations 1 through 5 and 7 mentioned in the "Combination of Loads" section.
2. When a lateral load,  $H$ , due to earth pressure, bulk material, or groundwater pressure is present, then include it with a factor of 1.6 if it adds to the load effect; if it acts against the other loads, use a factor of 0.9 when it is permanent and a factor of 0 when it is temporary.
3. When a structure is located in a flood zone, in V-zones, or coastal A-zones, the wind load in the above load combinations is replaced by  $1.0W + 2.0F_a$ , where  $F_a$  is a flood load; in noncoastal A-zones,  $1.0W$  in above combinations is replaced by  $0.5W + 1.0F_a$ .

### Example 1.4

A simply supported roof beam receives loads from the following sources taking into account the respective tributary areas. Determine the loading diagram for the beam according to the ASCE 7-10 combinations.

1. Dead load (1.2 k/ft. acting on a roof slope of  $10^\circ$ )
2. Roof live load (0.24 k/ft.)
3. Snow load (1 k/ft.)

4. Wind load at roof level (15 k)
5. Earthquake load at roof level (25 k)
6. Vertical earthquake load (0.2 k/ft.)

**SOLUTION**

1. The dead load and the vertical earthquake load which is related to the dead load, act on the entire member length. The other vertical forces act on the horizontal projection.
2. Adjusted dead load on horizontal projection =  $1.2/\cos 10^\circ = 1.22$  k/ft.
3. Adjusted vertical earthquake load on horizontal projection =  $0.2/\cos 10^\circ = 0.20$  k/ft.
4. Equation 1.21:  $W_v = 1.4D = 1.4(1.22) = 1.71$  k/ft.
5. Equation 1.22:  $W_v = 1.2D + 1.6L + 0.5 (L_r \text{ or } S)$ . This combination is shown in Table 1.3.

**TABLE 1.3**  
**Dead, Live, and Snow Loads for Item 5 Combination**

Source	D (k/ft.)	L (k/ft.)	L <sub>r</sub> or S (k/ft.)	Combined Value	Diagram
Load	1.22	–	1	1.964 k/ft.	
Load factor	1.2	1.6	0.5		
Factored vertical load	1.464	–	0.5		
Factored horizontal load	–	–	–		

**TABLE 1.4**  
**Dead, Live, Snow, and Wind Loads for Item 6 Combination**

Source	D (k/ft.)	L (k/ft.)	S (k/ft.)	W (k)	Combined Value	Diagram
Load	1.22	–	1	15	3.06 k/ft.	
Load factor	1.2	0.5	1.6	0.5		
Factored vertical load	1.464		1.6			
Factored horizontal load				7.5		

**TABLE 1.5**  
**Dead, Live, Snow, and Wind Loads for Item 7 Combination**

Source	D (k/ft.)	L (k/ft.)	S (k/ft.)	W (k)	Combined Value	Diagram
Load	1.22	–	1	15	1.964 k/ft.	
Load factor	1.2	0.5	0.5	1		
Factored vertical load	1.464	–	0.5			
Factored horizontal load				15		

- 6. Equation 1.23:  $W_u = 1.2D + 1.0(L_r \text{ or } S) + (0.5L \text{ or } 0.5W)$ . This combination is shown in Table 1.4.
- 7. Equation 1.24:  $W_u = 1.2D + 1.0W + 0.5L + 0.5(L_r \text{ or } S)$ . This combination is shown in Table 1.5.
- 8. Equation 1.25:  $W_u = 1.2D + E_v + E_h + 0.5L + 0.2S$ . This combination is shown in Table 1.6.
- 9. Equation 1.26:  $W_u = 0.9D + 1.0W$ . This combination is shown in Table 1.7.
- 10. Equation 1.27:  $W_u = 0.9D + E_h - E_v$ . This combination is shown in Table 1.8.

Item 5 can be eliminated as it is less than next three items. Items 6, 7, and 8 should be evaluated for the maximum effect and items 4, 9, and 10 for the least effect.

**TABLE 1.6**  
**Dead, Live, Snow, and Earthquake Loads for Item 8 Combination**

Source	D (k/ft.)	L (k/ft.)	S (k/ft.)	$E_v$ (k/ft.)	$E_h$ (k)	Combined Value	Diagram
Load	1.22	-	1	0.2	25		
Load factor	1.2	0.5	0.2	1	1		
Factored vertical load	1.464	-	0.2	0.2		1.864	
Factored horizontal load					25	25	

**TABLE 1.7**  
**Dead and Wind Loads for Item 9 Combination**

Source	D (k/ft.)	W (k)	Combined Value	Diagram
Load	1.22	15		
Load factor	0.9	1		
Factored vertical load	1.1		1.1 k/ft.	
Factored horizontal load		15	15 k	

**TABLE 1.8**  
**Dead and Earthquake Load for Item 10 Combination**

Source	D (k/ft.)	$E_v$ (k/ft.)	$E_h$ (k)	Combined Value	Diagram
Load	1.22	(-)0.2	25		
Load factor	0.9	1	1		
Factored vertical load	1.1	(-)0.2		0.9 k/ft.	
Factored horizontal load			25	25 k	

## CONTINUOUS LOAD PATH FOR STRUCTURAL INTEGRITY

ASCE 7-10 makes a new provision\* that all structures should be provided with a continuous load path and a complete lateral force-resisting system of adequate strength for the integrity of the structure. A concept of *notional load* has been adopted for this purpose. The notional load,  $N$ , has been stipulated as follows:

1. All parts of the structure between separation joints shall be interconnected. The connection should be capable of transmitting the lateral force induced by the parts being connected. Any smaller portion of a structure should be tied to the remainder of the structure through elements that have the strength to resist at least 5% of the weight of the portion being connected.
2. Each structure should be analyzed for lateral forces applied independently in two orthogonal directions. In each direction, the lateral forces at all levels should be applied simultaneously. The minimum design lateral force should be

$$F_x = 0.01W_x \quad (1.28)$$

where

$F_x$  is design lateral force applied at story  $x$

$W_x$  is dead load of the portion assigned to level  $x$

3. A positive connection to resist the horizontal force acting parallel to the member should be provided for each beam, girder, or truss either directly to its supporting elements or to slabs acting as diaphragms. Where this is through a diaphragm, the member's supporting element should be connected to the diaphragm also.

The connection should have the strength to resist 5% (unfactored) dead load plus live load reaction imposed by the supported member on the supporting member.

4. A wall that vertically bears the load or provides lateral shear resistance from a portion of a structure should be anchored to the roof, to all floors, and to members that are supported by the wall or provide support to the wall. The anchorage should make a direct connection capable of resisting a horizontal force, perpendicular to the plane of the wall, equal to 0.2 times the weight of the wall tributary to the connection but not less than 5 psf.

While considering load combinations, the notional load,  $N$ , specified in items 1 through 4 in this list should be combined with dead and live loads as follows:

1.  $1.2D + 1.0N + fL + 0.2S$  (1.29)

2.  $0.9D + 1.0N$  (1.30)

This is similar to the cases when earthquake loads are considered as in load combination Equations 1.25 and 1.27.

## PROBLEMS

**Note:** In Problems 1.1 through 1.6, the loads given are factored loads.

- 1.1 A floor framing plan is shown in Figure P1.1. The standard unit load on the floor is 60 lb/ft.<sup>2</sup> Determine the design uniform load per foot on the joists and the interior beam.
- 1.2 In Figure 1.5, length  $L = 50$  ft. and width  $B = 30$  ft. For a floor loading of 100 lb/ft.<sup>2</sup>, determine the design loads on beams GH, EF, and AD.

---

\* It was a part of the seismic design criteria of category A.

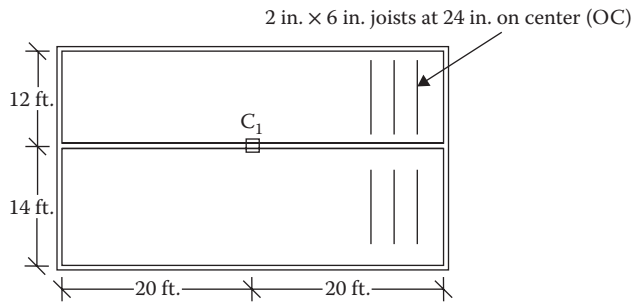


FIGURE P1.1 Floor framing plan.

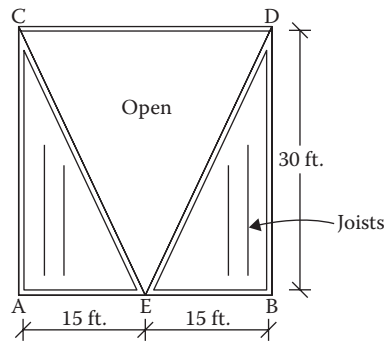


FIGURE P1.2 An open well framing plan.

- 1.3 In Figure 1.6, length  $L = 50$  ft. and width  $B = 30$  ft. and the loading is  $100$  lb/ft.<sup>2</sup> Determine the design loads on beams GH, EF, and AD.
- 1.4 An open well is framed so that beams CE and DE sit on beam AB, as shown in Figure P1.2. Determine the design load for beam CE and girder AB. The combined unit of dead and live loads is  $80$  lb/ft.<sup>2</sup>
- 1.5 A roof is framed as shown in Figure P1.3. The load on the roof is  $3$  kN/m<sup>2</sup>. Determine the design load distribution on the ridge beam.
- 1.6 Determine the size of the square wood column  $C_1$  from Problem 1.1 shown in Figure P1.1. Use a resistance factor of 0.8, and assume no slenderness effect. The yield strength of wood in compression is  $4000$  psi.
- 1.7 The service dead and live loads acting on a round tensile member of steel are  $10$  and  $20$  k, respectively. The resistance factor is 0.9. Determine the diameter of the member. The yield strength of steel is  $36$  ksi.
- 1.8 A steel beam spanning  $30$  ft. is subjected to a service dead load of  $400$  lb/ft. and a service live load of  $1000$  lb/ft. What is the size of a rectangular beam if the depth is twice the width? The resistance factor is 0.9. The yield strength of steel is  $50$  ksi.
- 1.9 Design the interior beam from Problem 1.1 in Figure P1.1. The resistance factor is 0.9. The depth is three times the width. The yield strength of wood is  $4000$  psi.
- 1.10 For a steel beam section shown in Figure P1.4, determine the (1) elastic moment capacity, (2) plastic moment capacity, and (3) shape factor. The yield strength is  $50$  ksi.
- 1.11 For the steel beam section shown in Figure P1.5, determine the (1) elastic moment capacity, (2) plastic moment capacity, and (3) shape factor. The yield strength is  $210$  MPa.  
[Hint: For elastic moment capacity, use the relation  $M_E = \sigma_y I/c$ . For plastic capacity, find the compression (or tensile) forces separately for web and flange of the section and apply these at the centroid of the web and flange, respectively.]

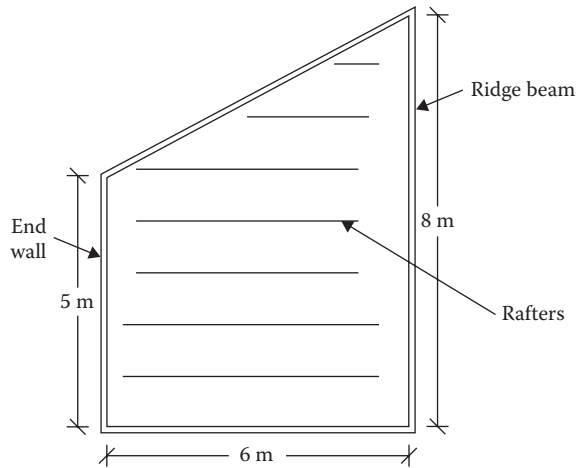


FIGURE P1.3 Roof frame.

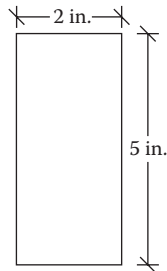


FIGURE P1.4 Rectangular beam section.

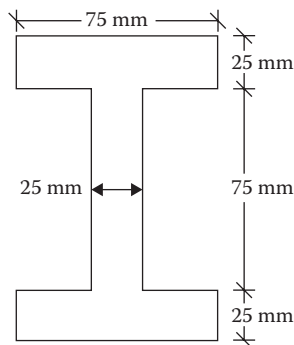
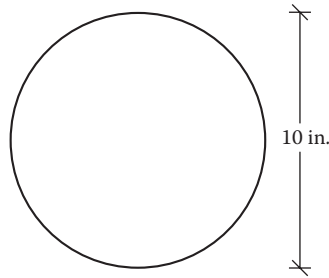
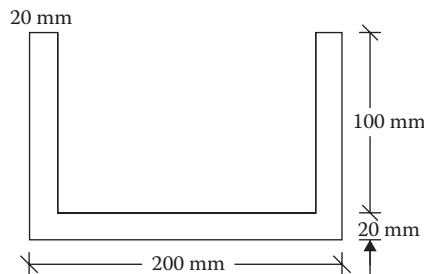


FIGURE P1.5 An I-beam section.

- 1.12** For a circular wood section as shown in Figure P1.6, determine the (1) elastic moment capacity, (2) plastic moment capacity, and (3) shape factor. The yield strength is 2000 psi.
- 1.13** For the asymmetric section shown in Figure P1.7, determine plastic moment capacity. The plastic neutral axis (where  $C = T$ ) is at 20 mm above the base. The yield strength is 275 MPa.
- 1.14** The design moment capacity of a rectangular beam section is 2000 ft·lb. The material's strength is 10,000 psi. Design a section having a width–depth ratio of 0.6 according to the (1) elastic theory and (2) plastic theory.



**FIGURE P1.6** A circular wood section.



**FIGURE P1.7** An asymmetric section.

- 1.15** For Problem 1.14, design a circular section.
- 1.16** The following vertical loads are applied on a structural member. Determine the critical vertical load in pounds per square foot for all the ASCE 7-10 combinations.
1. Dead load (on a  $15^\circ$  inclined member): 10 psf
  2. Roof live load: 20 psf
  3. Wind load (vertical component): 15 psf
  4. Snow load: 30 psf
  5. Earthquake load (vertical only): 2 psf
- 1.17** A floor beam supports the following loads. Determine the load diagrams for the various load combinations.
1. Dead load: 1.15 k/ft.
  2. Live load: 1.85 k/ft.
  3. Wind load (horizontal): 15 k
  4. Earthquake load (horizontal): 20 k
  5. Earthquake load (vertical): 0.3 k/ft.
- 1.18** A simply supported floor beam is subject to the loads shown in Figure P1.8. Determine the loading diagrams for various load combinations.
- 1.19** A beam supports the loads, shown in Figure P1.9. Determine the load diagrams for various load combinations.
- 1.20** In Problem 1.18, if load case 5 controls the design, determine the maximum axial force, shear force, and bending moment for which the beam should be designed.
- 1.21** How does the structural integrity of a building is ensured?
- 1.22** A three-story building has a total weight of 1000 k. The heights of the first, second, and third floors are 10, 9, and 8 ft., respectively. Determine the magnitudes of the minimum notional lateral forces that have to be considered for the structural integrity of the building assuming that the weight of the building is distributed according to the height of the floors.

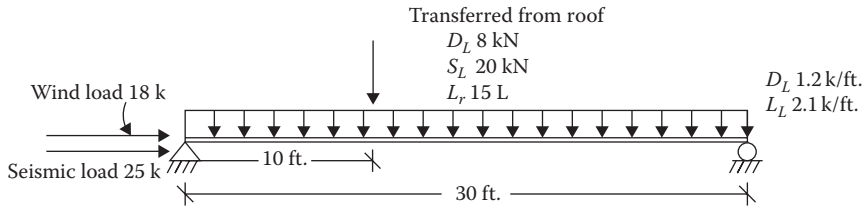


FIGURE P1.8 Loads on a beam for Problem 1.18.

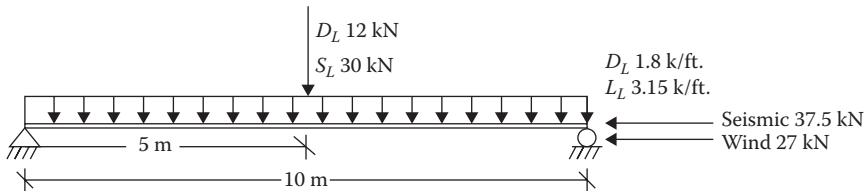


FIGURE P1.9 Loads on a beam for Problem 1.19.

- 1.23** Two end walls in shorter dimension (width) support the floor slabs of the building in Problem 1.22. Determine the notional forces on the anchorages at each floor level. The wall load is 40 psf.  
*[Hint: The weight of the wall assigned to each floor is according to the effective height of the wall for each floor.]*
- 1.24** A girder of 40 ft. span is supported at two ends. It has a dead load of 1 k/ft. and a live load of 2 k/ft. A positive connection is provided at each end between the girder and the supports. Determine the notional force for which the connection should be designed.



---

# 2 Primary Loads

## *Dead Loads and Live Loads*

### DEAD LOADS

Dead loads are due to the weight of all materials that constitute a structural member. This also includes the weight of fixed equipment that are built into the structure, such as piping, ducts, air conditioning, and heating equipment. The specific or unit weights of materials are available from different sources. Dead loads are, however, expressed in terms of uniform loads on a unit area (e.g., pounds per square foot). The weights are converted to dead loads taking into account the tributary area of a member. For example, a beam section weighting 4.5 lb/ft. when spaced 16 in. (1.33 ft.) on center will have a uniform dead load of  $4.5/1.33 = 3.38$  psf. If the same beam section is spaced 18 in. (1.5 ft.) on center, the uniform dead load will be  $4.5/1.5 = 3.5$  psf. The spacing of a beam section may not be known to begin with, as this might be an objective of the design.

Moreover, the estimation of dead load of a member requires knowledge as to what items and materials constitute that member. For example, a wood roof comprises roof covering, sheathing, framing, insulation, and ceiling.

It is expeditious to assume a reasonable dead load for a structural member, only to be revised when found grossly out of order.

The dead load of a building of light frame construction is about 10 lb/ft.<sup>2</sup> for a flooring or roofing system without plastered ceilings and 20 lb/ft.<sup>2</sup> with plastered ceilings. For a concrete flooring system, each 1 in. thick slab has a uniform load of about 12 psf; this is 36 psf for a 3 in. slab. To this, at least 10 psf should be added for the supporting system. Dead loads are gravity forces that act vertically downward. On a sloped roof, the dead load acts over the entire inclined length of the member.

### Example 2.1

The framing of a roof consists of the following: asphalt shingles (2 psf), 0.75 in. plywood (2.5 psf), 2 × 8 framing at 12 in. on center (2.5 psf), fiberglass 0.5 in. insulation (1 psf), and plastered ceiling (10 psf). Determine the roof dead load. Make provisions for reroofing (3 psf).

### SOLUTION

	Dead Load (psf)
Shingles	2
Plywood	2.5
Framing	2.5
Insulation	1
Ceiling	10
Reroofing	3
Roof dead load	21

## LIVE LOADS

Live loads also act vertically down like dead loads but are distinct from the latter as they are not an integral part of the structural element. Roof live loads,  $L_r$ , are associated with maintenance of a roof by workers, equipment, and material. They are treated separately from the other types of live loads,  $L$ , that are imposed by the use and occupancy of the structure. ASCE 7-10 specifies the minimum uniformly distributed load or the concentrated load that should be used as a live load for an intended purpose. Both the roof live load and the floor live load are subjected to a reduction when they act on a large tributary area since it is less likely that the entire large area will be loaded to the same magnitude of high unit load. This reduction is not allowed when an added measure of safety is desired for important structures.

## FLOOR LIVE LOADS

The floor live load is estimated by the equation

$$L = kL_0 \quad (2.1)$$

where

$L_0$  is basic design live load (see the section “Basic Design Live Load,  $L_0$ ”).

$k$  is area reduction factor (see the section “Effective Area Reduction Factor”).

## BASIC DESIGN LIVE LOAD, $L_0$

ASCE 7-10 provides a comprehensive table for basic design loads arranged by occupancy and use of a structure. This has been consolidated under important categories in Table 2.1.

To generalize, the basic design live loads are as follows:

Above-the-ceiling storage areas: 20 psf; one- or two-family sleeping areas: 30 psf; normal use rooms: 40 psf; special use rooms (office, operating, reading, and fixed sheet arena): 50–60 psf; public assembly places: 100 psf; lobbies, corridors, platforms, and stadium\*: 100 psf for first floor and 80 psf for other floors; light industrial uses: 125 psf; and heavy industrial uses: 250 psf.

## EFFECTIVE AREA REDUCTION FACTOR

Members that have more than 400 ft.<sup>2</sup> of influence area are subject to a reduction in basic design live loads. The influence area is defined as the tributary area,  $A_T$ , multiplied by an element factor,  $K_{LL}$ , as listed in Table 2.2.

The following cases are excluded from the live load reduction:

1. Heavy live loads that exceed 100 psf
2. Passenger car garages
3. Public assembly areas

Except the aforementioned three items, for all other cases the reduction factor is given by

$$k = \left( 0.25 + \frac{15}{\sqrt{K_{LL} A_T}} \right) \quad (2.2)$$

---

\* In addition to vertical loads, horizontal swaying forces are applied to each row of sheets as follows: 24 lb per linear foot of seat in the direction parallel to each row of sheets and 10 lb per linear foot of sheet in the direction perpendicular to each row of sheets. Both the horizontal forces need not be applied simultaneously.

---

**TABLE 2.1**  
**Summarized Basic Design Live Loads**

Category	Uniform Load (psf)
Residential	
Storage area	20
Sleeping area (dwelling)	30
Living area, stairs (dwelling)	40
Hotel room	40
Garage	40
Office	50
Computer room/facility	100
School classroom	40
Hospital	
Patient room	40
Operation room/lab	60
Library	
Reading room	60
Stacking room	150
Industrial manufacturing/warehouse	
Light	125
Heavy	250
Corridor/lobby	
First floor	100
Above first floor	80
Public places <sup>a</sup>	100

<sup>a</sup> Balcony, ballroom, fire escape, gymnasium, public stairs/exits, restaurant, stadium, store, terrace, theater, yard, and so on.

---



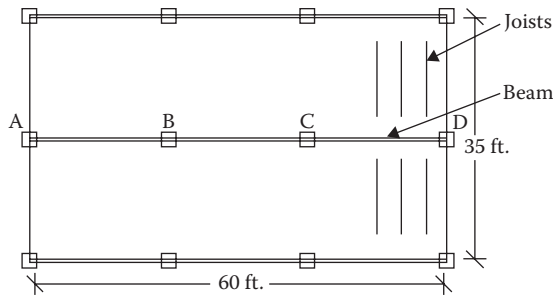
---

**TABLE 2.2**  
**Live Load Element Factor,  $K_{LL}$**

Structure Element	$K_{LL}$
Interior columns	4
Exterior columns without cantilever slabs	4
Edge columns with cantilever slabs	3
Corner columns with cantilever slabs	2
Edge beams without cantilever slabs	2
Interior beams	2
All other members not identified including the following:	1
Edge beams with cantilever slabs	
Cantilever beams	
One-way slabs	
Two-way slabs	

*Note:* Members without provisions for continuous shear transfer normal to their span.

---



**FIGURE 2.1** Floor framing plan.

As long as the following limits are observed, Equation 2.2 can be applied to any area. However, with the limits imposed the factor  $k$  becomes effective when  $K_{LL}A_T$  is greater than 400, as stated earlier:

1. The  $k$  factor should not be more than 1.
2. The  $k$  factor should not be less than 0.5 for members supporting one floor and 0.4 for members supporting more than one floor.

### Example 2.2

The first floor framing plan of a single family dwelling is shown in Figure 2.1. Determine the magnitude of live load on the interior column C.

### SOLUTION

1. From Table 2.1,  $L_0 = 40$  psf
2. Tributary area  $A_T = 20 \times 17.5 = 350$  ft.<sup>2</sup>
3. From Table 2.2,  $K_{LL} = 4$
4.  $K_{LL}A_T = 4 \times 350 = 1400$
5. From Equation 2.2

$$K = \left( 0.25 + \frac{15}{\sqrt{K_{LL}A_T}} \right)$$

$$= \left( 0.25 + \frac{15}{\sqrt{1400}} \right) = 0.65$$

6. From Equation 2.1,  $L = kL_0 = 0.65 (40) = 26$  psf

### OTHER PROVISIONS FOR FLOOR LIVE LOADS

Besides uniformly distributed live loads, ASCE 7-10 also indicates the concentrated live loads in certain cases that are assumed to be distributed over an area of 2.5 ft.  $\times$  2.5 ft. The maximum effect of either the uniformly distributed load or the concentrated load has to be considered. In most cases, the uniformly distributed loads have higher magnitudes.

In buildings where partitions are likely to be erected, a uniform partition live load is provided in addition to the basic design loads. The minimum partition load is 15 psf. Partition live loads are not subjected to reduction for large effective areas.

Live loads include an allowance for an ordinary impact. However, where unusual vibrations and impact forces are involved live loads should be increased. The moving loads shall be increased by an impact factor as follows: (1) elevator, 100%; (2) light shaft or motor-driven machine, 20%; (3) reciprocating machinery, 50%; and (4) hangers for floor or balcony, 33%. After including these effects,

$$\text{Total LL/unit area} = \text{unit LL} (1 + \text{IF}) + \text{PL} \{ \text{min } 15 \text{ psf} \} \quad (2.3)$$

where

LL is live load

IF is impact factor, in decimal point

PL is partition load

### MULTIPLE FLOORS REDUCTIONS

In one- and two-family dwellings, for members supporting more than one floor load the following live load reduction is permitted as an alternative to Equations 2.1 and 2.2:

$$L = 0.7 (L_{01} + L_{02} + L_{03} + \dots) \quad (2.4)$$

where  $L_{01}$ ,  $L_{02}$ , ... are the unreduced floor live loads applied on each of the multiple story levels regardless of tributary area. The reduced floor live load,  $L$ , should not be less than the largest unreduced floor live load on any one story level acting alone.

#### Example 2.3

An interior column supports the following unit live loads from three floors on a surface area of 20 ft.  $\times$  30 ft. each: first floor = 35 psf, second floor = 30 psf, and third floor = 25 psf. Determine the design unit live load on the column.

### SOLUTION

1. Total load = 35 + 30 + 25 = 90 psf
2. Tributary area  $A_T = 20 \times 30 = 600 \text{ ft.}^2$
3. From Table 2.2,  $K_{LL} = 4$
4.  $K_{LL}A_T = 4 \times 600 = 2400 \text{ ft.}^2$
5. From Equation 2.2

$$k = \left( 0.25 + \frac{15}{\sqrt{2400}} \right) = 0.556$$

6. From Equation 2.1  
 $L = kL_0 = 0.556 (90) = 50 \text{ psf}$
7. From the alternative equation (Equation 2.4)  
 $L = 0.7 \times (35 + 30 + 25) = 63 \text{ psf} \leftarrow \text{controls}$

Live load should not be less than maximum on any floor of 35 psf.

## ROOF LIVE LOADS, $L_r$

Roof live loads happen for a short time during the roofing or reroofing process. In load combinations, either the roof live load,  $L_r$ , or the snow load,  $S$ , is included, since both of these are not likely to occur simultaneously.

The standard roof live load for ordinary flat, sloped, or curved roofs is 20 psf. This can be reduced to a minimum value of 12 psf based on the tributary area being larger than 200 ft.<sup>2</sup> and/or the roof slope being more than 18.4°. When less than 20 psf of roof live loads are applied to a continuous beam structure, the reduced roof live load is applied to adjacent spans or alternate spans, whichever produces the greatest unfavorable effect.

The roof live load is estimated by

$$L_r = R_1 R_2 L_0 \quad (2.5)$$

where

$L_r$  is reduced roof live load on a horizontally projected surface

$L_0$  is basic design load for ordinary roof, which is 20 psf

$R_1$  is tributary area reduction factor (see the section “Tributary Area Reduction Factor,  $R_1$ ”)

$R_2$  is slope reduction factor (see the section “Slope Reduction Factor”)

## TRIBUTARY AREA REDUCTION FACTOR, $R_1$

This is given by

$$R_1 = 1.2 - 0.001A_T \quad (2.6)$$

where  $A_T$  is the horizontal projection of roof tributary area in square feet.

This is subject to the following limitations:

1.  $R_1$  should not exceed 1.
2.  $R_1$  should not be less than 0.6.

## SLOPE REDUCTION FACTOR

This is given by

$$R_2 = 1.2 - 0.6 \tan \theta \quad (2.7)$$

where  $\theta$  is the roof slope angle.

This is subject to the following limitations:

1.  $R_2$  should not exceed 1.
2.  $R_2$  should not be less than 0.6.

### Example 2.4

The horizontal projection of a roof framing plan of a building is similar to Figure 2.1. The roof pitch is 7 on 12. Determine the roof live load acting on column C.

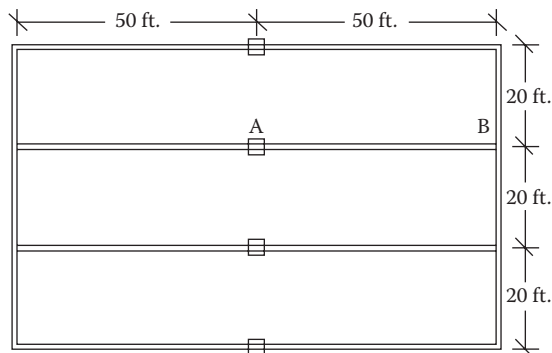
**SOLUTION**

1.  $L_0 = 20$  psf
2.  $A_T = 20 \times 17.5 = 350$  ft.<sup>2</sup>
3. From Equation 2.6,  $R_1 = 1.2 - 0.001 (350) = 0.85$
4. Pitch of 7 on 12,  $\tan \theta = 7/12$  or  $\theta = 30.256^\circ$
5. From Equation 2.7,  $R_2 = 1.2 - 0.6 \tan 30.256^\circ = 0.85$
6. From Equation 2.5,  $L_r = (0.85) (0.85) (20) = 14.45$  psf > 12 psf **OK**

The aforementioned computations are for an ordinary roof. Special purpose roofs such as roof gardens have loads up to 100 psf. These are permitted to be reduced according to floor live load reduction, as discussed in the "Floor Live Loads" section.

**PROBLEMS**

- 2.1 A floor framing consists of the following: hardwood floor (4 psf), 1 in. plywood (3 psf), 2 in.  $\times$  12 in. framing at 4 in. on center (2.6 psf), ceiling supports (0.5 psf), and gypsum wallboard ceiling (5 psf). Determine the floor dead load.
- 2.2 In Problem 2.1, the floor covering is replaced by a 1 in. concrete slab and the framing by 2 in.  $\times$  12 in. at 3 in. on center. Determine the floor dead load.  
[Hint: Weight in pounds of concrete/unit area = 1 ft.  $\times$  1 ft.  $\times$  1/12 ft.  $\times$  150.]
- 2.3 For the floor framing plan of Example 2.2, determine the design live load on the interior beam BC.
- 2.4 An interior steel column of an office building supports a unit load, as indicated in Table 2.1, from the floor above. The column to column distance among all columns in the floor plan is 40 ft. Determine the design live load on the column.
- 2.5 The framing plan of a gymnasium is shown in Figure P2.1. Determine the live load on column A.
- 2.6 Determine the live load on the slab resting on column A from Problem 2.5.
- 2.7 The column in Problem 2.4 supports the same live loads from two floors above. Determine the design live load on the column.
- 2.8 A corner column with a cantilever slab supports the following live loads over an area of 25 ft.  $\times$  30 ft. Determine the design live load. First floor = 30 psf, second floor = 25 psf, and third floor = 20 psf.
- 2.9 The column in Problem 2.8 additionally supports an elevator and hangers of a balcony. Determine the design load.



**FIGURE P2.1** Framing plan for Problem 2.5.

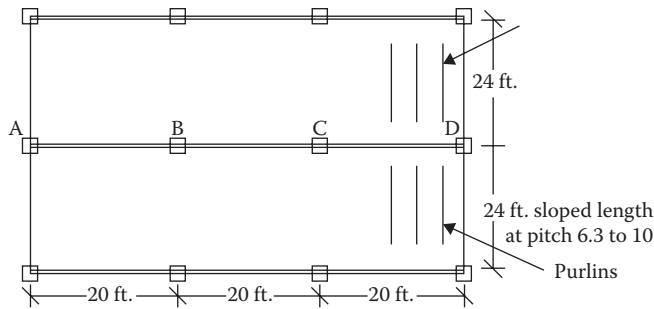


FIGURE P2.2 Roofing plan for Problem 2.11.

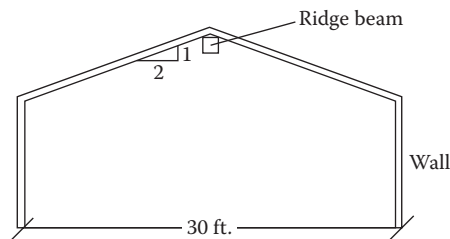


FIGURE P2.3 Side elevation of building for Problem 2.13.

- 2.10** The building in Problem 2.5 includes partitioning of the floor, and it is equipped with a reciprocating machine that induces vibrations on the floor. Determine the design live load on beam AB.
- 2.11** Determine the roof live load acting on the end column D of the roofing plan shown in Figure P2.2.
- 2.12** Determine the roof live load on the purlins of Figure P2.2 if they are 4 ft. apart.
- 2.13** A roof framing section is shown in Figure P2.3. The length of the building is 40 ft. The ridge beam has supports at two ends and at midlength. Determine the roof live load on the ridge beam.
- 2.14** Determine the load on the walls due to the roof live load from Problem 2.13.
- 2.15** An interior column supports loads from a roof garden. The tributary area to the column is  $250 \text{ ft.}^2$ . Determine the roof live load. Assume a basic roof garden load of 100 psf.



---

# 3 Snow Loads

## INTRODUCTION

Snow is a controlling roof load in about half of all the states in the United States. It is a cause of frequent and costly structural problems. Snow loads are assumed to act on the horizontal projection of the roof surface.

Snow loads have the following components:

1. Balanced snow load
2. Rain-on-snow surcharge
3. Partial loading of the balanced snow load
4. Unbalanced snow load due to a drift on one roof
5. Unbalanced load due to a drift from an upper roof to a lower roof
6. Sliding snow load

For low-slope roofs, ASCE 7-10 prescribes a minimum load that acts by itself and not combined with other snow loads.

The following snow loading combinations are considered:

1. Balanced snow load *plus* rain-on-snow when applicable, or the minimum snow load
2. Partial loading (of balanced snow load without rain-on-snow)
3. Unbalanced snow load (without rain-on-snow)
4. Balanced snow load (without rain-on-snow) *plus* drift snow load
5. Balanced snow load (without rain-on-snow) *plus* sliding snow load

## MINIMUM SNOW LOAD FOR LOW-SLOPE ROOFS

The slope of a roof is defined as a *low slope* if mono, hip, and gable roofs have a slope of less than 15° and a curved roof has a vertical angle from eave to crown of less than 10°.

The minimum snow load for low-slope roofs should be obtained from the following equations:

1. When the ground snow load,  $p_g$ , is 20 lb/ft.<sup>2</sup> or less

$$p_m = I p_g \quad (3.1)$$

2. When the ground snow load is more than 20 lb/ft.<sup>2</sup>

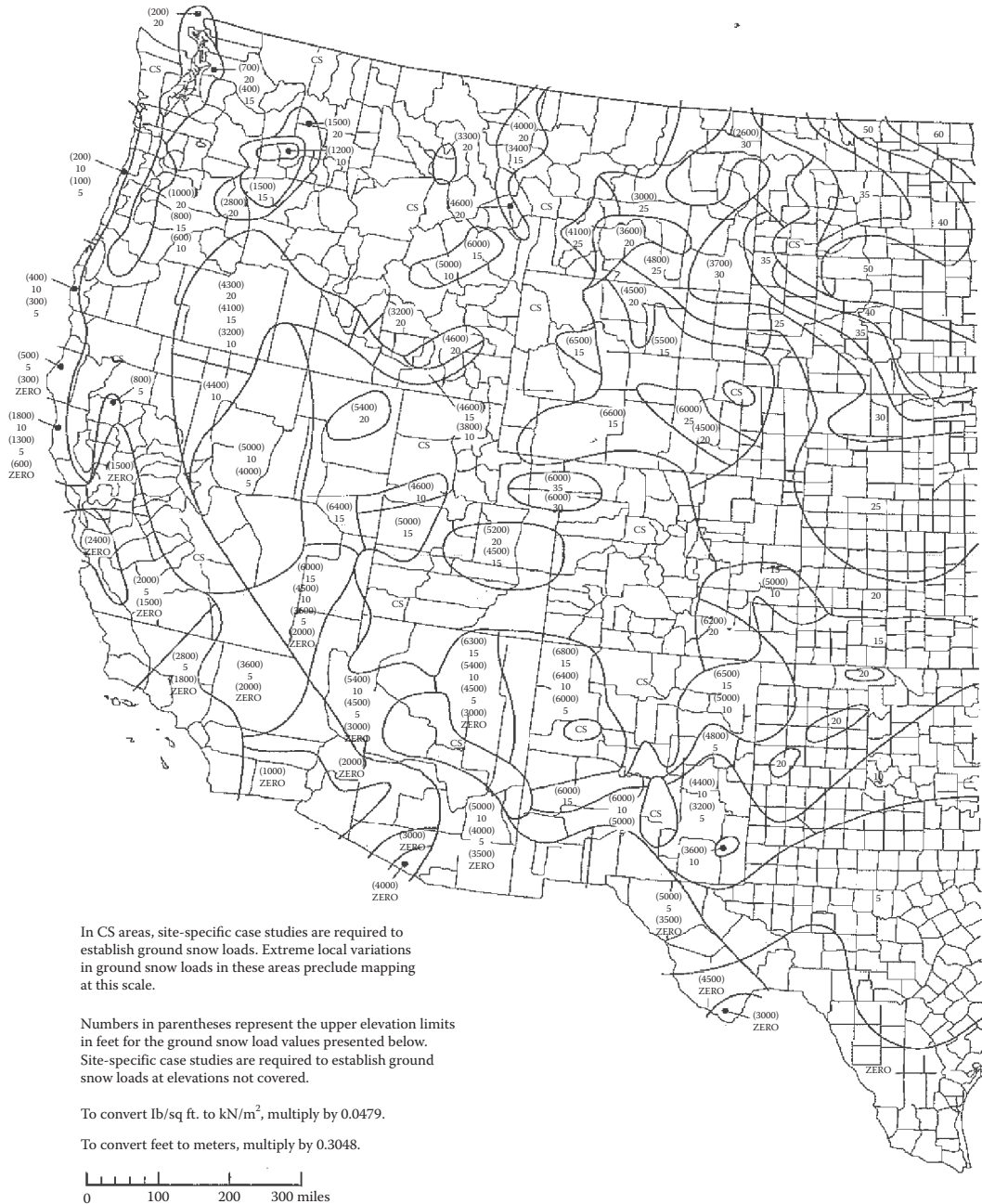
$$p_m = 20 I \quad (3.2)$$

where

$p_g$  is 50-year ground snow load from Figure 3.1

$I$  is importance factor (see the “Importance Factor” section)

As stated, the minimum snow load,  $p_m$ , is considered a separate uniform load case. It is not combined with other loads—balanced, rain-on-snow, unbalanced, partial, drift, or sliding loads.



In CS areas, site-specific case studies are required to establish ground snow loads. Extreme local variations in ground snow loads in these areas preclude mapping at this scale.

Numbers in parentheses represent the upper elevation limits in feet for the ground snow load values presented below. Site-specific case studies are required to establish ground snow loads at elevations not covered.

To convert lb/sq ft. to kN/m<sup>2</sup>, multiply by 0.0479.

To convert feet to meters, multiply by 0.3048.

(a)

**FIGURE 3.1** Ground snow loads,  $p_g$ , for the United States. The entire country is divided in two parts. (a) and (b) distinguishes two parts. (Courtesy of American Society of Civil Engineers, Reston, VA.)



**FIGURE 3.1 (Continued)** Ground snow loads,  $p_g$ , for the United States. (Courtesy of American Society of Civil Engineers, Reston, VA.)

## BALANCED SNOW LOAD

This is the basic snow load to which a structure is subjected. The procedure to determine the balanced snow load is as follows:

1. Determine the ground snow load,  $p_g$ , from the snow load map in ASCE 7-10, reproduced in Figure 3.1.
2. Convert the ground snow load to flat roof snow load (roof slope  $\leq 5^\circ$ ),  $p_f$ , with consideration given to the (1) roof exposure, (2) roof thermal condition, and (3) occupancy category of the structure:

$$p_f = 0.7C_eC_tIp_g \quad (3.3)$$

3. Apply a roof slope factor to the flat roof snow load to determine the sloped (balanced) roof snow load.
4. Combining the preceding steps, the sloped roof snow load is calculated from

$$p_s = 0.7C_sC_eC_tIp_g \quad (3.4)$$

where

$p_g$  is 50-year ground snow load from Figure 3.1

$I$  is importance factor (see the “Importance Factor” section)

$C_t$  is thermal factor (see the “Thermal Factor,  $C_t$ ” section)

$C_e$  is exposure factor (see the “Exposure Factor,  $C_e$ ” section)

$C_s$  is roof slope factor (see the “Roof Slope Factor,  $C_s$ ” section)

It should be noted that when the slope is larger than  $70^\circ$ , the slope factor  $C_s = 0$ , and the balanced snow load is zero.

## IMPORTANCE FACTOR

Depending on the risk category identified in the “Classification of Buildings” section of Chapter 1, the importance factor is determined from Table 3.1

## THERMAL FACTOR, $C_t$

The factors are given in Table 3.2. The intent is to account for the heat loss through the roof and its effect on snow accumulation. For modern, well-insulated, energy-efficient construction with eave and ridge vents, the common  $C_t$  value is 1.1.

---

**TABLE 3.1**  
**Importance Factor for Snow Load**

Risk Category	Importance Factor
I. Structures of low hazard to human life	0.8
II. Standard structures	1.0
III. High occupancy structures	1.1
IV. Essential structures	1.2

Source: Courtesy of American Society of Civil Engineers, Reston, VA.

---

**TABLE 3.2**  
**Thermal Factor,  $C_t$**

Thermal Condition	$C_t$
All structures except as indicated below	1.0
Structures kept just above freezing and other structures with cold, ventilated well insulated roofs ( $R$ -value $> 25 \text{ ft}^2 \text{ hr}^0\text{F/Btu}$ )	1.1
Unheated and open air structures	1.2
Structures intentionally kept below freezing	1.3
Continuously heated greenhouses	0.85

**TABLE 3.3**  
**Exposure Factor for Snow Load**

Terrain	Fully Exposed	Partially Exposed	Sheltered
B. Urban, suburban, wooded, closely spaced dwellings	0.9	1.0	1.2
C. Open areas of scattered obstructions, flat open country and grasslands	0.9	1.0	1.1
D. Flat unobstructed areas and water surfaces, smooth mud and salt flats	0.8	0.9	1.0
Above the tree line in mountainous region	0.7	0.8	–
Alaska: treeless	0.7	0.8	–

### EXPOSURE FACTOR, $C_e$

The factors, as given in Table 3.3, are a function of the surface roughness (terrain type) and the location of the structure within the terrain (sheltered to fully exposed).

It should be noted that exposure A representing centers of large cities where over half the buildings are greater than 70 ft. is not recognized separately in ASCE 7-10. This type of terrain is included in exposure B.

The sheltered areas correspond to the roofs that are surrounded on all sides by the obstructions that are within a distance of  $10h_o$ , where  $h_o$  is the height of the obstruction above the roof level. Fully exposed roofs have no obstruction within  $10h_o$  on all sides including no large rooftop equipment or tall parapet walls. The partially exposed roofs represent structures that are not sheltered or fully exposed. The partial exposure is a most common exposure condition.

### ROOF SLOPE FACTOR, $C_s$

This factor decreases as the roof slope increases. Also, the factor is smaller for slippery roofs and warm roof surfaces.

ASCE 7-10 provides the graphs of  $C_s$  versus roof slope for three separate thermal factors,  $C_t$ , that is,  $C_t$  of  $\leq 1.0$  (warm roofs),  $C_t$  of 1.1 (cold well-insulated and ventilated roofs), and  $C_t$  of 1.2 (cold roofs). On the graph for each value of the thermal factor, two curves are shown. The dashed line is for an unobstructed slippery surface and the solid line is for other surfaces. The dashed line of unobstructed slippery surfaces has smaller  $C_s$  values.

An unobstructed surface has been defined as a roof on which no object exists that will prevent snow from sliding and there is a sufficient space available below the eaves where the sliding snow can accumulate. The slippery surface includes metal, slate, glass, and membranes. For the warm roof case ( $C_t \leq 1$ ), to qualify as an unobstructed slippery surface, there is a further requirement

**TABLE 3.4**  
**Roof Slope Factor,  $C_s$**

Thermal Factor	Unobstructed Slippery Surface	Other Surfaces
	$R \geq 30 \text{ ft}^2 \text{ hr}^0\text{F/Btu}$ for unventilated and $R \geq 20 \text{ ft}^2 \text{ hr}^0\text{F/Btu}$ for ventilated	
Warm roofs ( $C_t \leq 1$ )	$\theta = 0^\circ - 5^\circ C_s = 1$ $\theta = 5^\circ - 70^\circ C_s = 1 - \frac{\theta - 5^\circ}{65^\circ}$ $\theta > 70^\circ C_s = 0$	$\theta = 0^\circ - 30^\circ C_s = 1$ $\theta = 30^\circ - 70^\circ C_s = 1 - \frac{\theta - 30^\circ}{40^\circ}$ $\theta > 70^\circ C_s = 0$
Cold roofs ( $C_t = 1.1$ )	$\theta = 0^\circ - 10^\circ C_s = 1$ $\theta = 10^\circ - 70^\circ C_s = 1 - \frac{\theta - 10^\circ}{60^\circ}$ $\theta > 70^\circ C_s = 0$	$\theta = 0^\circ - 37.5^\circ C_s = 1$ $\theta = 37.5^\circ - 70^\circ C_s = 1 - \frac{\theta - 37.5^\circ}{32.5^\circ}$ $\theta > 70^\circ C_s = 0$
Cold roofs ( $C_t = 1.2$ )	$\theta = 0^\circ - 15^\circ C_s = 1$ $\theta = 15^\circ - 70^\circ C_s = 1 - \frac{\theta - 15^\circ}{55^\circ}$ $\theta > 70^\circ C_s = 0$	$\theta = 0^\circ - 45^\circ C_s = 1$ $\theta = 45^\circ - 70^\circ C_s = 1 - \frac{\theta - 45^\circ}{25^\circ}$ $\theta > 70^\circ C_s = 0$

Note:  $\theta$  is the slope of the roof.

with respect to the  $R$  (thermal resistance) value. The values of  $C_s$  can be expressed mathematically, as given in Table 3.4. It will be seen that for nonslippery surfaces like asphalt shingles, which is a common case, the  $C_s$  factor is relevant only for roofs having a slope larger than  $30^\circ$ ; for slopes larger than  $70^\circ$ ,  $C_s = 0$ .

## RAIN-ON-SNOW SURCHARGE

An extra load of  $5 \text{ lb/ft}^2$  has to be added due to rain-on-snow for locations where the following two conditions apply: (1) the ground snow load,  $p_g$ , is  $\leq 20 \text{ lb/ft}^2$  and (2) the roof slope is less than  $W/50$ ,  $W$  being the horizontal eave-to-ridge roof distance. This extra load is applied only to the balanced snow load case and should not be used in combination with minimum, unbalanced, partial, drift, and sliding load cases.

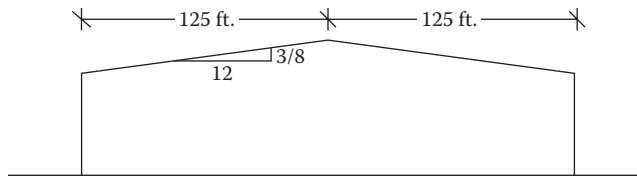
### Example 3.1

Determine the balanced load for an unheated building of ordinary construction shown in Figure 3.2 in a suburban area with tree obstruction within a distance of  $10h_o$ . The ground snow load is  $20 \text{ psf}$ .

## SOLUTION

### A. Parameters

- $p_g = 20 \text{ psf}$
- Unheated roof,  $C_t = 1.20$
- Ordinary building,  $l = 1.0$
- Suburban area (terrain B), sheltered, exposure factor,  $C_e = 1.2$
- Roof angle,  $\tan \theta = \frac{3/8}{12} = 0.0313; \theta = 1.8^\circ$



**FIGURE 3.2** Low-slope roof.

6.  $\theta < 15^\circ$ , it is a low slope, the minimum load equation applies
  7.  $\frac{W}{50} = \frac{125}{50} = 2.5$
  8.  $\theta < 2.5^\circ$  and  $p_g = 20$  psf, rain-on-snow surcharge = 5 lb/ft.<sup>2</sup>
  9. From Table 3.4,  $C_s = 1.0$
- B. Snow loads
1. Minimum snow load, from Equation 3.1

$$p_m = (1)(20) = 20 \text{ lb/ft.}^2$$

2. From Equation 3.4

$$\begin{aligned} p_s &= 0.7C_sC_eC_t/p_g \\ &= 0.7(1)(1.2)(1.2)(1)(20) = 20.16 \text{ lb/ft.}^2 \end{aligned}$$

3. Add rain-on-snow surcharge

$$p_b = 20.16 + 5 = 25.16 \text{ lb/ft.}^2 \leftarrow \text{controls}$$

### Example 3.2

Determine the balanced snow load for an essential facility in Seattle, Washington, having a roof eave to ridge width of 100 ft. and a height of 25 ft. It is a warm roof structure.

### SOLUTION

A. Parameters

1. Seattle, Washington,  $p_g = 20$  psf
2. Warm roof,  $C_t = 1.00$
3. Essential facility,  $I = 1.2$
4. Category B, urban area, partially exposed (default), exposure factor,  $C_e = 1.00$
5. Roof slope,  $\tan \theta = \frac{25}{100} = 0.25$ ;  $\theta = 14^\circ$ .
6.  $\theta < 15^\circ$ , the minimum snow equation is applicable
7.  $\theta$  is not less than  $W/50$ , there is no rain-on-snow surcharge
8. For a warm roof, other structures, from Table 3.4  $C_s = 1$

B. Snow loads

1.  $p_m = (1.2)(20) = 24 \text{ lb/ft.}^2 \leftarrow \text{controls}$
2.  $p_s = 0.7C_sC_eC_t/p_g$   
 $= 0.7(1)(1)(1.2) = 16.8 \text{ lbs/ft.}^2$

### PARTIAL LOADING OF THE BALANCED SNOW LOAD

The partial loads are different from the unbalanced loads. In unbalanced loads, snow is removed from one portion and is deposited in another portion. In the case of partial loading, snow is removed from one portion through scour or melting but is not added to another portion. The intent is that in

a continuous span structure, a reduction in snow loading on one span might induce heavier stresses in some other portion than those that occur with the entire structure being loaded. The provision requires that a selected span or spans should be loaded with one-half of the balanced snow load and the remaining spans with the full balanced snow load. This should be evaluated for various alternatives to assess the greatest effect on the structural member.

Partial load is not applied to the members that span perpendicular to the ridgeline in gable roofs having slopes  $2.38^\circ$  or more.

## UNBALANCED ACROSS THE RIDGE SNOW LOAD

The balanced and unbalanced loads are analyzed separately.

The unbalanced loading condition results from when a blowing wind depletes snow from the upwind direction to pile it up in the downward direction.

The unbalanced snow loading for hip and gable roofs is discussed here. For curved, saw tooth, and dome roofs, a reference is made to Sections 7.6.2 through 7.6.4 of ASCE 7-10.

For unbalanced load to occur on any roof, it should be neither a very low-slope roof nor a steep roof. Thus, the following two conditions should be satisfied for across the ridge unbalanced snow loading:

1. The roof slope should be equal to or larger than  $2.38^\circ$ .
2. The roof slope should be less than  $30.2^\circ$ .

When the preceding two conditions are satisfied, the unbalanced load distribution is expressed in two different ways:

1. For narrow roofs ( $W \leq 20$  ft.) of simple structural systems like the prismatic wood rafters or light gauge roof rafters spanning from eave to ridge, the windward side is taken as free of snow, and on the leeward side the total snow load is represented by a uniform load from eave to ridge as follows (note this is the total load and is not an addition to the balanced load):

$$p_u = Ip_g \quad (3.5)$$

2. For wide roofs ( $W > 20$  ft.) of any structures as well as the narrow roofs of other than the simple structures stated in the preceding discussion, the load is triangular in shape but is represented by a more user-friendly rectangular surcharge over the balanced load.

On the windward side, a uniform load of  $0.3p_s$  is applied, where  $p_s$  is the balanced snow load mentioned in the "Balanced Snow Load" section. On the leeward side, a rectangular load is placed adjacent to the ridge, on top of the balanced load,  $p_s$ , as follows:

$$\text{Uniform load, } p_u = \frac{h_d \gamma}{\sqrt{s}} \quad (3.6)$$

$$\text{Horizontal extent from ridge, } L = \frac{8h_d \sqrt{s}}{3} \quad (3.7)$$

where

$\frac{1}{s}$  is roof slope

$\gamma$  is unit weight of snow in  $\text{lb/ft.}^3$ , given by

$$\gamma = 0.13p_g + 14 \leq 30 \text{ lb/ft.}^3 \quad (3.8)$$



$h_d$  is height of drift in feet on the leeward roof, given by

$$h_d = 0.43(W)^{1/3}(p_g + 10)^{1/4} - 1.5 \tag{3.9}$$

$W$  is horizontal distance from eave to ridge for the windward portion of the roof in feet. If  $W < 20$  ft., use  $W = 20$  ft.

**Example 3.3**

Determine the unbalanced drift snow load for Example 3.1.

**SOLUTION**

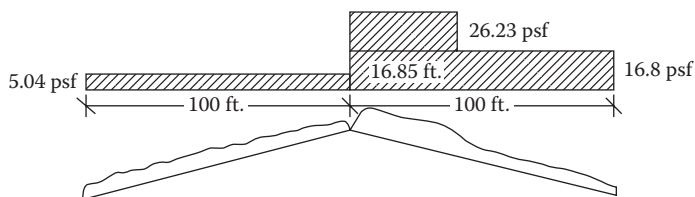
1. Roof slope,  $\theta = 1.8^\circ$ .
2. Since roof slope  $< 2.38^\circ$ , there is no unbalanced snow load.

**Example 3.4**

Determine the unbalanced drift snow load for Example 3.2.

**SOLUTION**

- A. On leeward side
  1. Roof slope,  $\theta = 14^\circ$ , it is not a low-slope roof for unbalanced load.
  2.  $W > 20$  ft., it is a wide roof.
  3.  $p_g = 20$  psf and  $p_s = 16.8$  lb/ft.<sup>2</sup> (from Example 3.2).
  4. slope =  $\frac{1}{s} = \frac{25}{100}$  or  $s = 4$
  5.  $h_d = 0.43(W)^{1/3}(p_g + 10)^{1/4} - 1.5$   
 $= 0.43(100)^{1/3}(20 + 10)^{1/4} - 1.5 = 3.16$
  6. Unit weight of snow  
 $\gamma = 0.13p_g + 14 \leq 30$   
 $= 0.13(20) + 14 = 16.6$  lb/ft.<sup>3</sup>
  7.  $p_u = \frac{h_d \gamma}{\sqrt{s}}$   
 $= \frac{(3.16)(16.6)}{\sqrt{4}} = 26.23$  lb/ft.<sup>2</sup>
  8. Horizontal extent,  $L = \frac{8h_d \sqrt{s}}{3} = \frac{8(3.16)\sqrt{4}}{3} = 16.85$  ft.
- B. On windward side
  9.  $p_u = 0.3 p_s = 0.3 (16.8) = 5.04$  psf.
  10. This is sketched in Figure 3.3.



**FIGURE 3.3** Unbalanced snow load on a roof.

### SNOW DRIFT FROM A HIGHER TO A LOWER ROOF

The snow drifts are formed in the wind shadow of a higher structure onto a lower structure. The lower roof can be a part of the same structure or it could be an adjacent separated structure.

This drift is a surcharge that is superimposed on the balanced snow roof load of the lower roof. The drift accumulation, when the higher roof is on the windward side, is shown in Figure 3.4. This is known as the *leeward snow drift*.

When the higher roof is on the leeward side, the drift accumulation, known as the *windward snow drift*, is more complex. It starts as a quadrilateral shape because of the wind vortex and ends up in a triangular shape, as shown in Figure 3.5.

### LEEWARD SNOW DRIFT ON LOWER ROOF OF ATTACHED STRUCTURE

In Figure 3.4, if  $h_c/h_b$  is less than 0.2, the drift load is not applied, where  $h_b$  is the balanced snow depth determined by dividing the balanced snow load,  $p_s$ , by a unit load of snow,  $\gamma$ , computed by Equation 3.7. The term  $h_c$  represents the difference of elevation between high and low roofs subtracted by  $h_b$ , as shown in Figure 3.4.

The drift is represented by a triangle, as shown in Figure 3.6.

$$h_d = 0.43(L_u)^{1/3}(p_g + 10)^{1/4} - 1.5 \tag{3.10}$$

where  $L_u$  is horizontal length of the roof upwind of the drift, as shown in Figure 3.4.

The corresponding maximum snow load is

$$p_d = \gamma h_d \tag{3.11}$$

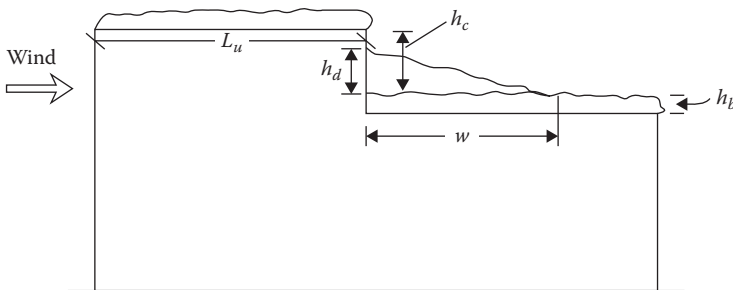


FIGURE 3.4 Leeward snow drift.

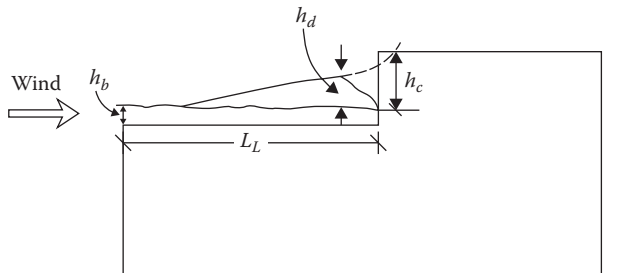


FIGURE 3.5 Windward snow drift.

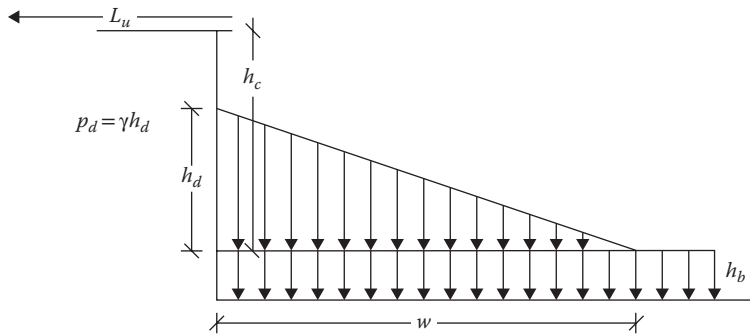


FIGURE 3.6 Configuration of snow drift.

The width of the snow load (base of the triangle) has the following value for two different cases:

1. For  $h_d \leq h_c$

$$w = 4h_d \quad (3.12)$$

2. For  $h_d > h_c$

$$w = \frac{4h_d^2}{h_c} \quad (3.13)$$

but  $w$  should not be greater than  $8h_c$ .

In Equation 3.13,  $w$  is computed by the value of  $h_d$  from Equation 3.9, which is higher than  $h_c$  for the case of Equation 3.13. However, since the drift height cannot exceed the upper roof level, the height of the drift itself is subsequently changed as follows:

$$h_d = h_c \quad (3.14)$$

If width,  $w$ , is more than the lower roof length,  $L_L$ , then the drift shall be truncated at the end of the roof and not reduced to zero there.

### WINDWARD SNOW DRIFT ON LOWER ROOF OF ATTACHED STRUCTURE

In Figure 3.5, if  $h_c/h_b$  is less than 0.2, the drift load is not applied. The drift is given by a triangle similar to the one shown in Figure 3.6. However, the value of  $h_d$  is replaced by the following:

$$h_d = 0.75[0.43(L_L)^{1/3}(p_g + 10)^{1/4} - 1.5] \quad (3.15)$$

where  $L_L$  is lower roof length as shown in Figure 3.5.

Equations 3.12 and 3.13 apply to windward width also.

The larger of the values of the leeward and windward heights,  $h_d$ , from Leeward Snow Drift and Windward Snow Drift sections is used in the design.

**LEEWARD SNOW DRIFT ON LOWER ROOF OF SEPARATED STRUCTURE**

If the vertical separation distance between the edge of the higher roof including any parapet and the edge of the adjacent lower roof excluding any parapet is  $h$ , and the horizontal separation between the edges of the two adjacent buildings is  $s$ , then the leeward drift to the lower roof is applicable if the following two conditions are satisfied:

1. The horizontal distance,  $s$ , is less than 20 ft.
2. The horizontal distance,  $s$ , is less than six times the vertical distance,  $h$  ( $s \leq 6h$ ).

In such a case, the height of the snow drift is the smaller of the following:

1.  $h_d$  as calculated by Equation 3.10 based on the length of the higher structure
2.  $\frac{(6h - s)}{6}$

The horizontal extent,  $w$ , is the smaller of the following:

1.  $6h_d$
2.  $(6h - s)$

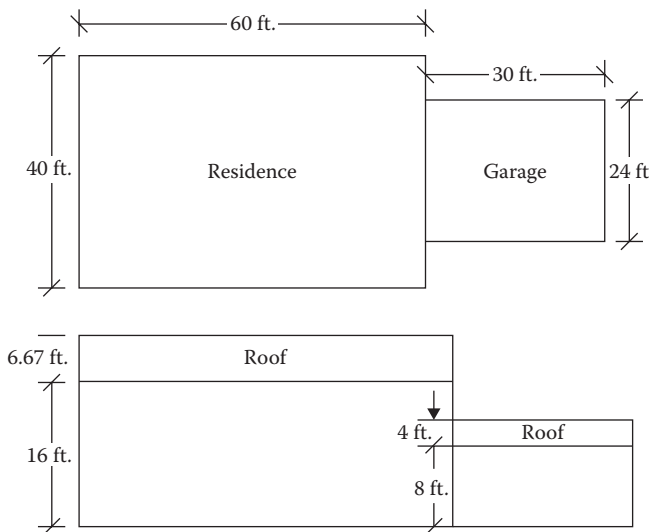
**WINDWARD SNOW DRIFT ON LOWER ROOF OF SEPARATED STRUCTURE**

The same equations as for the windward drift on an attached structure, that is, Equation 3.15 for  $h_d$  and Equation 3.12 or 3.13 for  $w$  are used. However, the portion of the drift between the edges of the two adjacent roofs is truncated.

**Example 3.5**

A two-story residential building has an attached garage, as shown in Figure 3.7. The residential part is heated and has a well-insulated, ventilated roof, whereas the garage is unheated. Both roofs of 4 on 12 slope have metal surfaces consisting of the purlins spanning eave to ridge.

The site is a forested area in a small clearing among huge trees. The ground snow load is 40 psf. Determine the snow load on the lower roof.



**FIGURE 3.7** Higher–lower roof drift.

**SOLUTION**

1. The upper roof is subjected to the balanced snow load and the unbalanced across the ridge load due to wind in the transverse direction.
2. The lower roof is subjected to the balanced snow load, the unbalanced across the ridge load due to transverse directional wind, and the drift load from upper to lower roof due to longitudinal direction wind. Only the lower roof is analyzed here.
3. For the lower roof, the balanced load
  - a. Unheated roof,  $C_t = 1.2$
  - b. Residential facility,  $l = 1.0$
  - c. Terrain B, sheltered,  $C_e = 1.2$
  - d. 4 on 12 slope,  $\theta = 18.43^\circ$
  - e. For slippery unobstructed surface at  $C_t = 1.2$ , from Table 3.4

$$C_s = 1 - \frac{(\theta - 15)}{55} = 1 - \frac{(18.43 - 15)}{55} = 0.94$$

$$\begin{aligned} \text{f. } p_s &= 0.7C_sC_eC_t/p_g \\ &= 0.7(0.94)(1.2)(1.2)(1)(40) = 37.90 \text{ lb/ft.}^2 \end{aligned}$$

4. For the lower roof, across the ridge unbalanced load
  - a.  $W = 12 < 20$  ft., roof rafter system, the simple case applies
  - b. Windward side no snow load
  - c. Leeward side

$$p_u = lp_g = 1(40) = 40 \text{ psf}$$

5. For lower roof, upper–lower roof drift snow load
  - a. From Equation 3.8

$$\gamma = 0.13p_g + 14 = 0.13(40) + 14 = 19.2 \text{ lb/ft.}^3$$

- b.  $h_b = \frac{p_s}{\gamma} = \frac{37.9}{19.2} = 1.97 \text{ ft.}$
- c.  $h_c = (22.67 - 12) - 1.97 = 8.7 \text{ ft.}$

$$\frac{h_c}{h_b} = \frac{8.7}{1.97} = 4.4 > 0.2 \text{ drift load to be considered}$$

- d. Leeward drift  
From Equation 3.10

$$\begin{aligned} h_d &= 0.43(L_u)^{1/3}(p_g + 10)^{1/4} - 1.5 \\ &= 0.43(60)^{1/3}(40 + 10)^{1/4} - 1.5 = 2.97 \end{aligned}$$

Since  $h_c > h_d$ ,  $h_d = 2.97 \text{ ft.}$

- e.  $p_d = \gamma h_d = (19.2)(2.97) = 57.03 \text{ lb/ft.}^2$
- f. From Equation 3.12

$$w = 4h_d = 4(2.97) = 11.88 \text{ ft.}$$

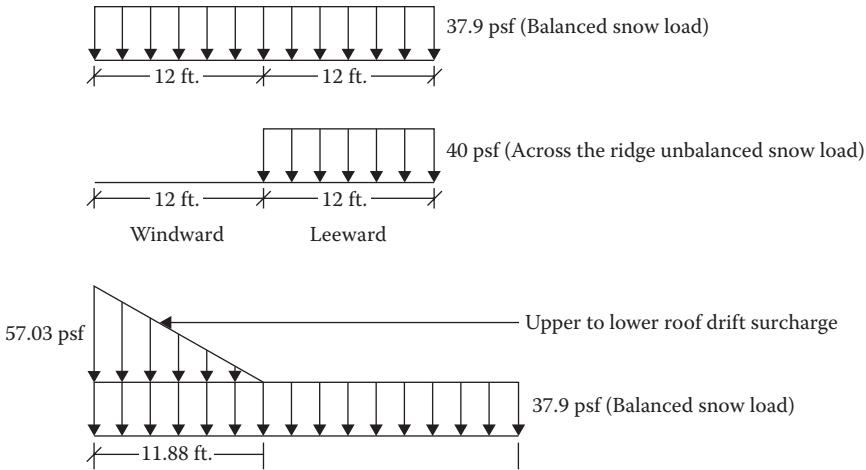


FIGURE 3.8 Loading on a lower roof.

g. Windward drift

$$\begin{aligned}
 h_d &= 0.75[0.43(L_L)^{1/3}(p_g + 10)^{1/4} - 1.5] \\
 &= 0.75[0.43(30)^{1/3}(40 + 10)^{1/4} - 1.5] \\
 &= 1.54 \text{ ft.} < 2.97 \text{ ft., leeward controls}
 \end{aligned}$$

6. Figure 3.8 presents the three loading cases for the lower roof.

### SLIDING SNOW LOAD ON LOWER ROOF

A sliding snow load from an upper to a lower roof is superimposed on the balanced snow load. It is not used in combination with partial, unbalanced, drift, or rain-on-snow loads. The sliding load (plus the balanced load) and the lower roof drift load (plus the balanced load) are considered as two separate cases and the higher one is used. One basic difference between a slide and a drift is that in the former case, snow slides off the upper roof along the slope by the action of gravity and the lower roof should be in front of the sloping surface to capture this load. In the latter case, wind carries the snow downstream and thus the drift can take place lengthwise perpendicular to the roof slope, as in Example 3.5.

The sliding snow load is applied to the lower roof when the upper slippery roof has a slope of more than  $\theta = 2.4^\circ$  (1/4 on 12) or when the nonslippery upper roof has a slope greater than  $9.5^\circ$  (2 on 12).

With reference to Figure 3.9, the total sliding load per unit distance (length) of eave is taken as  $0.4 p_f W$ , which is uniformly distributed over a maximum lower roof width of 15 ft. If the width of the lower roof is less than 15 ft., the sliding load is reduced proportionately. The effect is that it is equivalent to distribution over a 15 ft. width.

Thus,

$$P_{SL} = \frac{0.4 p_f W}{15} \tag{3.16}$$

where

$p_f$  is flat upper roof snow load (psf) from Equation 3.1

$W$  is horizontal distance from ridge to eave of the upper roof

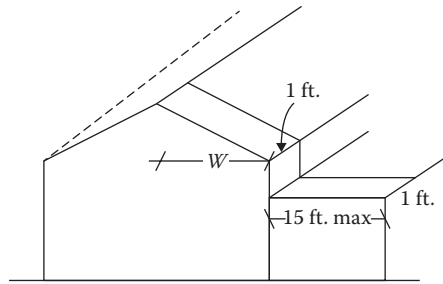


FIGURE 3.9 Sliding snow load.

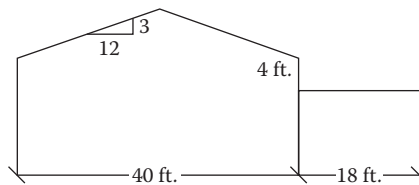


FIGURE 3.10 Sliding snow load on a flat roof.

### Example 3.6

Determine the sliding snow load on an unheated flat roof garage attached to a residence, as shown in Figure 3.10. It is in a suburban area with scattered trees.  $p_g = 20$  psf. Assume that the upper roof flat snow load is 18 psf.

### SOLUTION

#### A. Balanced load on garage

1. Unheated roof,  $C_t = 1.2$
2. Normal usage,  $I = 1$
3. Terrain B, partial exposure,  $C_e = 1$
4. Flat roof,  $C_s = 1$
5. Minimum snow load

Since  $p_g = 20$  and  $\theta = 0$ , the minimum load applies but it is not combined with any other types (balanced, unbalanced, drift, and sliding) of loads.

$$\begin{aligned} p_m &= I p_g \\ &= (1)(20) = 20 \end{aligned}$$

#### 6. Balanced snow load

$$\begin{aligned} p_s &= 0.7 C_s C_e C_t I p_g \\ &= 0.7(1)(1)(1.2)(1)(20) = 16.8 \text{ lb/ft.}^2 \end{aligned}$$

#### 7. Rain-on-snow surcharge = 5 psf

Since  $p_g = 20$  and  $\theta < W/50$ , rain-on-snow surcharge applies, but it is not included in the unbalanced, drift, and sliding load cases.

- B.  $\theta < 2.38^\circ$ ; there is no unbalanced across the ridge load.
- C. Drift load not considered in this problem.
- D. Sliding snow load

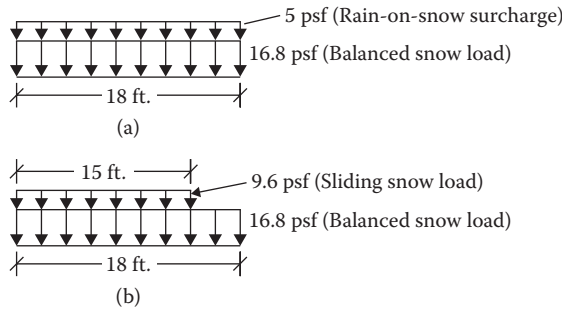


FIGURE 3.11 Loading on lower roof. (a) Balanced snow load and (b) balanced plus sliding snow load.

1. Upper roof slope  $\theta = 14^\circ > 9.5^\circ$ , sliding applies
2.  $p_f = 18 \text{ lb/ft.}^2$  (given)
3.  $p_{SL} = \frac{0.4 p_f W}{15} = \frac{(0.4)(18)(20)}{15} = 9.6 \text{ psf}$

Figure 3.11 presents the loading cases for the garage.

### SLIDING SNOW LOAD ON SEPARATED STRUCTURES

The lower separated roof is subjected to a truncated sliding load if the following two conditions are satisfied:

1. The separation distance between the structures,  $s$ , is less than 15 ft.
2. The vertical distance between the structures,  $h$ , is greater than the horizontal distance,  $s$

$$(h > s)$$

The sliding load per unit area,  $p_{SL}$ , is the same as given by Equation 3.16 but the horizontal extent on the lower roof is  $(15 - s)$ . Thus, the load per unit length is

$$S_L = \frac{0.4 p_f W(15 - s)}{15} \tag{3.17}$$

### PROBLEMS

- 3.1 Determine the balanced snow load on the residential structure shown in Figure P3.1 in a suburban area. The roof is well insulated and ventilated. There are a few trees behind the building to create obstruction. The ground snow load is  $20 \text{ lb/ft.}^2$

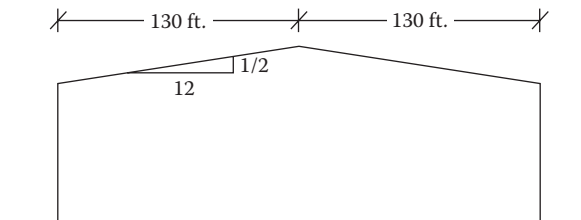


FIGURE P3.1 Suburban residence for Problem 3.1.



- 3.2 Solve Problem 3.1 except that the eave-to-ridge distance is 30 ft.
- 3.3 Consider a heated warm roof structure in an urban area surrounded by obstructions from all sides. The eave-to-ridge distance is 25 ft. and the roof height is 7 ft. The ground snow load is 30 psf. Determine the balanced snow load.
- 3.4 The roof of a high occupancy structure is insulated and well ventilated in a fully open countryside. The eave-to-ridge distance is 20 ft. and the roof height is 4 ft. The ground snow load is 25 psf. Determine the balanced snow load.
- 3.5 Determine the unbalanced load for Problem 3.1.
- 3.6 Determine the unbalanced load for Problem 3.2.
- 3.7 Determine the unbalanced snow load for Problem 3.3.
- 3.8 Determine the unbalanced snow load for Problem 3.4.
- 3.9 Determine snow load on the lower roof of a building where the ground snow load is 30 lb/ft.<sup>2</sup> The elevation difference between the roofs is 5 ft. The higher roof is 70 ft. wide and 100 ft. long. It is a heated and unventilated office building. The lower roof is 60 ft. wide and 100 ft. long. It is an unheated storage area. Both roofs have 5 on 12 slope of metallic surfaces without any obstructions. The building is located in an open country with no obstructions. The building is laid out lengthwise, as shown in Figure P3.2.
- 3.10 Solve Problem 3.9 except that the roofs' elevation difference is 3 ft.
- 3.11 Solve Problem 3.9 when the building is laid out side by side, as shown in Figure P3.3. The lowest roof is flat.
- 3.12 Solve Problem 3.9. The two roofs are separated by a horizontal distance of 15 ft.
- 3.13 Solve Problem 3.11. The two roofs are separated by a horizontal distance of 10 ft.
- 3.14 Solve Problem 3.11 for the sliding snow load.

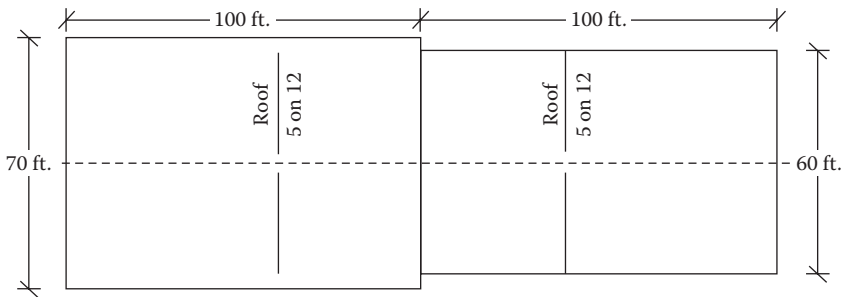


FIGURE P3.2 Different level roofs lengthwise for Problem 3.9.

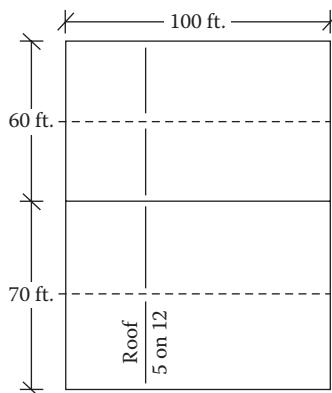


FIGURE P3.3 Different level roofs side by side for Problem 3.11.

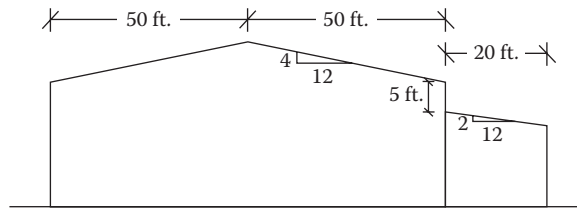


FIGURE P3.4 Sliding snow on urban building for Problem 3.15.

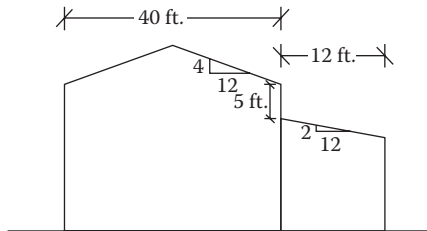


FIGURE P3.5 Sliding snow on suburban building for Problem 3.16.

- 3.15 Determine the snow load due to sliding effect for a heated storage area attached to an office building with a well-ventilated/insulated roof in an urban area in Rhode Island having scattered obstructions, as shown in Figure P3.4.
- 3.16 Determine the sliding load for an unheated garage attached to a cooled roof of a residence shown in Figure P3.5 in a partially exposed suburban area. The ground snow load is 15 lb/ft.<sup>2</sup>
- 3.17 Solve Problem 3.15. The two roofs are separated by a horizontal distance of 2 ft.
- 3.18 Solve Problem 3.16. The two roofs are separated by a horizontal distance of 3 ft.

---

# 4 Wind Loads

## INTRODUCTION

ASCE 7-10 has made major revisions to wind load provisions; from one single chapter (Chapter 6) in ASCE 7-05, six chapters (Chapters 26 through 31) have been incorporated in ASCE 7-10. The provisions and the data have been revised to reflect the strength (load resistance factor design) level of design.

Two separate categories have been identified for wind load provisions:

1. **Main wind force-resisting system (MWFRS):** MWFRS represents the entire structure comprising an assemblage of the structural elements constituting the structure that can sustain wind from more than one surface.
2. **Components and cladding (C and C):** These are the individual elements that face wind directly and pass on the loads to the MWFRS.

The broad distinction is apparent. The entire lateral force-resisting system as a unit that transfers loads to the foundation belongs to the first category. In the second category, the cladding comprises wall and roof coverings like sheathing and finish material, curtain walls, exterior windows, and doors. The components include fasteners, purlins, girts, and roof decking.

However, there are certain elements like trusses and studs that are part of the MWFRS but could also be treated as individual components.

The C and C loads are higher than MWFRS loads since they are developed to represent the peak gusts over small areas that result from localized funneling and turbulence of wind.

An interpretation has been made that while using MWFRS, the combined interactions of the axial and bending stresses due to the vertical loading together with the lateral loading should be used. But in the application of C and C, either the axial or the bending stress should be considered individually. They are not combined together since the interaction of loads from multiple surfaces is not intended to be used in C and C.

## DEFINITION OF TERMS

1. **Low-rise building:** An enclosed or partially enclosed building that has a mean roof height of less than or equal to 60 ft. and the mean roof height does not exceed the least horizontal dimension.
2. **Open, partially enclosed, and enclosed building:** An open building has at least 80% open area in each wall, that is,  $A_o/A_g \geq 0.8$ , where  $A_o$  is total area of openings in a wall and  $A_g$  is the total gross area of that wall.

A partially enclosed building complies with both of the two conditions: (1) the total area of openings in a wall that receives the external positive pressure exceeds the sum of the areas of openings in the balance of the building including roof by more than 10% and (2) the total area of openings in a wall that receives the positive external pressure exceeds 4 ft.<sup>2</sup> or 1% of the area of that wall, whichever is smaller, and the percentage of openings in the balance of the building envelope does not exceed 20%.

An enclosed building is one that is not open and that is not partially enclosed.

3. **Regular-shaped building:** A building not having any unusual irregularity in spatial form.

4. **Diaphragm building:** Roof, floor, or other membrane or bracing system in a building that transfers lateral forces to the vertical MWFRS.
5. **Hurricane-prone regions:** Areas vulnerable to hurricanes comprising (1) the U.S. Atlantic Ocean and Gulf of Mexico coasts where the basic wind speed is more than 115 miles/h and (2) Hawaii, Puerto Rico, Guam, Virgin Island, and American Samoa, covered as special wind regions in basic wind speed maps.
6. **Special wind regions:** Regions mentioned as item (2) under hurricane-prone regions. These should be examined for higher local winds.
7. **Mean roof height\*:** The average of the height to the highest point on roof and the eave height, measured from ground surface. For a roof angle of  $10^\circ$  or less, it is taken to be the eave height.

## PROCEDURES FOR MWFRS

The following procedures have been stipulated for MWFRS in ASCE 7-10:

1. Wind tunnel procedure: This applies to all types of buildings and structures of all heights as specified in Chapter 31.
2. Analytical directional procedure: This applies to regular-shaped buildings of all heights as specified in Part 1 of Chapter 27.
3. Simplified directional procedure: This applies to regular-shaped enclosed simple diaphragm buildings of 160 ft. or less height as specified in Part 2 of Chapter 27.
4. Analytical envelope procedure: This applies to regular-shaped low-rise buildings of 60 ft. or less height as specified in Part 1 of Chapter 28.
5. Simplified envelope procedure: This applies to enclosed simple diaphragm low-rise buildings of 60 ft. or less height as specified in Part 2 of Chapter 28. Since this procedure can be applied to one- and two-story buildings in most locations, it has been adopted in this book.

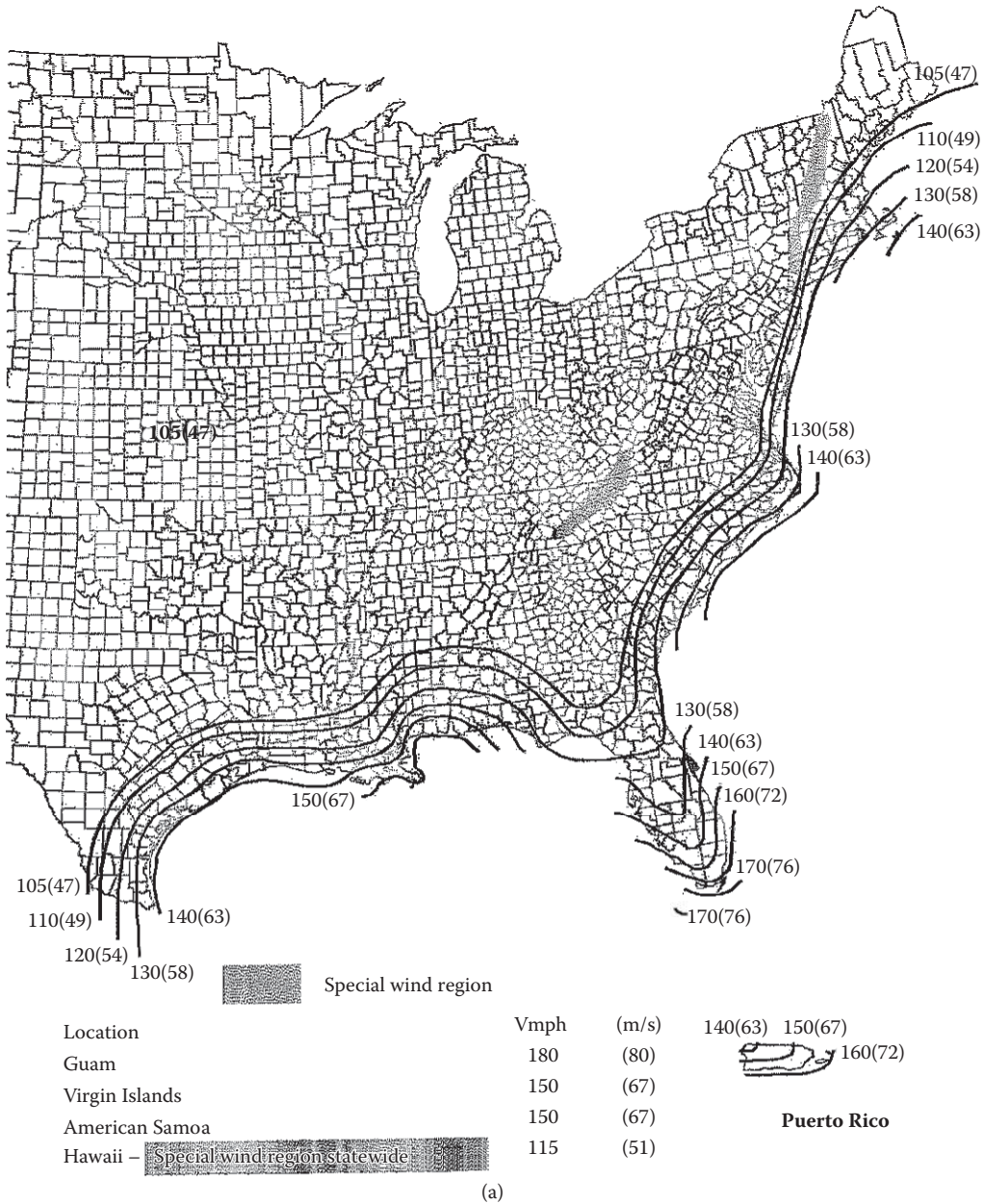
## SIMPLIFIED PROCEDURE FOR MWFRS FOR LOW-RISE BUILDINGS

The following are the steps of the procedure:

1. Determine the basic wind speed,  $V$ , corresponding to the risk category of the building from one of the Figures 4.1 through 4.3.
2. Determine the upwind exposure category depending on the surface roughness that prevails in the upwind direction of the structure, as indicated in Table 4.1.
3. Determine the height and exposure adjustment coefficient  $\lambda$  from Table 4.2.
4. The topographic factor,  $K_{zt}$ , has to be applied to a structure that is located on an isolated hill of at least 60 ft. height for exposure  $B$  and of at least 15 ft. height for exposures  $C$  and  $D$ , and it should be unobstructed by any similar hill for at least a distance of 100 times the height of the hill or 2 miles, whichever is less, and the hill should also protrude above the height of upwind terrain features within 2 miles radius by a factor of 2 or more. The factor is assessed by the three multipliers that are presented in Figure 26.8-1 of ASCE 7-10. For usual cases,  $K_{zt} = 1$ .
5. Determine  $p_{s30}$  from Table 4.3, reproduced from ASCE 7-10. For roof slopes more than  $25^\circ$  and less than or equal to  $45^\circ$ ; check for both load cases 1 and 2 in the table.

---

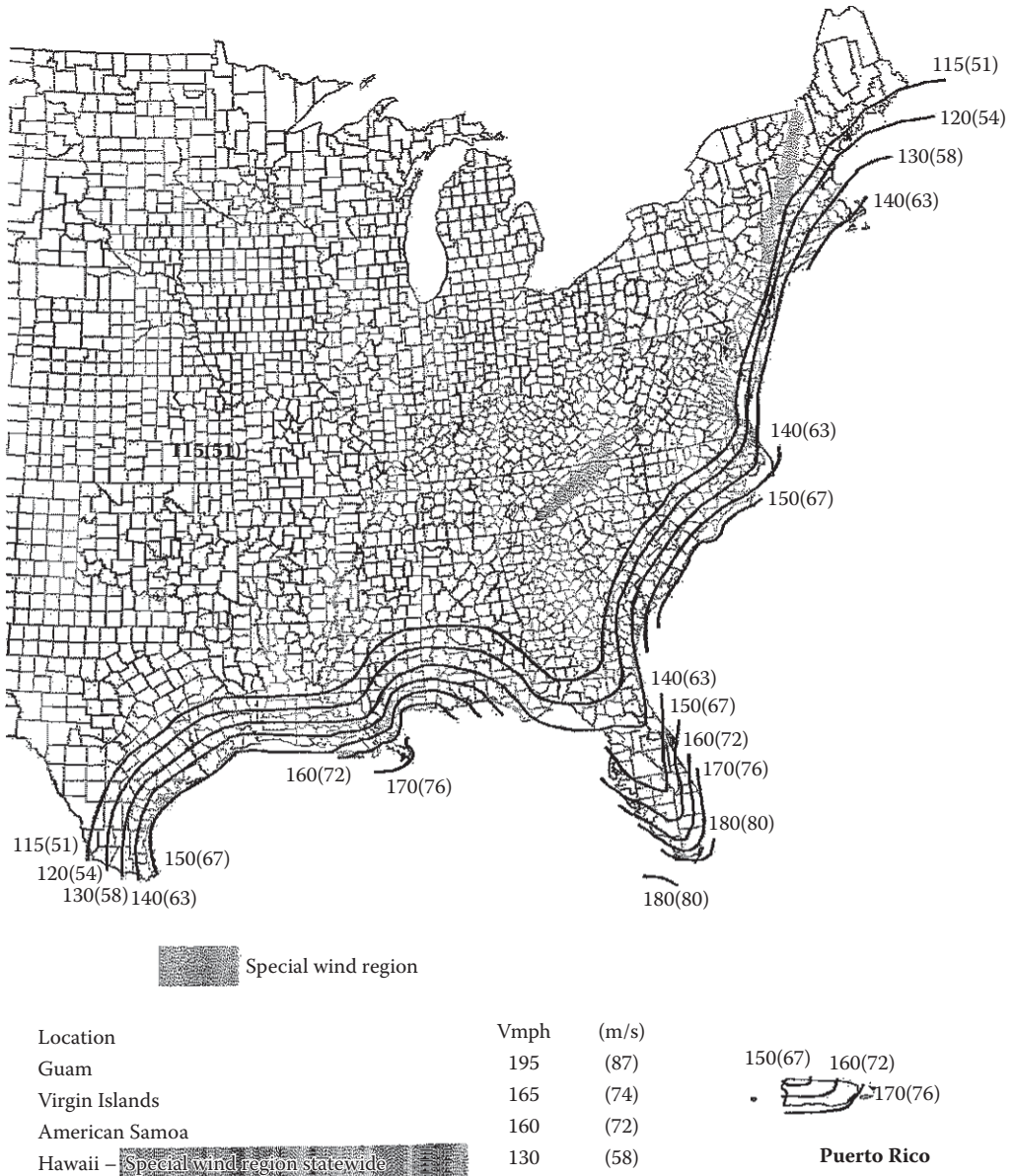
\* For seismic loads, the height is measured from the base of the structure.



**FIGURE 4.1** Basic wind speed for risk category I buildings. (a) and (b) simply divides the country in two halves. *Notes:* 1. Values are nominal design 3-second gust wind speeds in miles per hour (m/s) at 33 ft. (10 m) above ground for exposure C category. 2. Linear interpolation between contours is permitted. 3. Islands and coastal areas outside the last contour shall use the last wind speed contour of the coastal area. 4. Mountainous terrain, gorges, ocean promontories, and special wind regions shall be examined for unusual wind conditions. 5. Wind speeds correspond to approximately a 15% probability of exceedance in 50 years (Annual Exceedance Probability = 0.00333, MRI = 300 years). (Courtesy of American Society of Civil Engineers.)

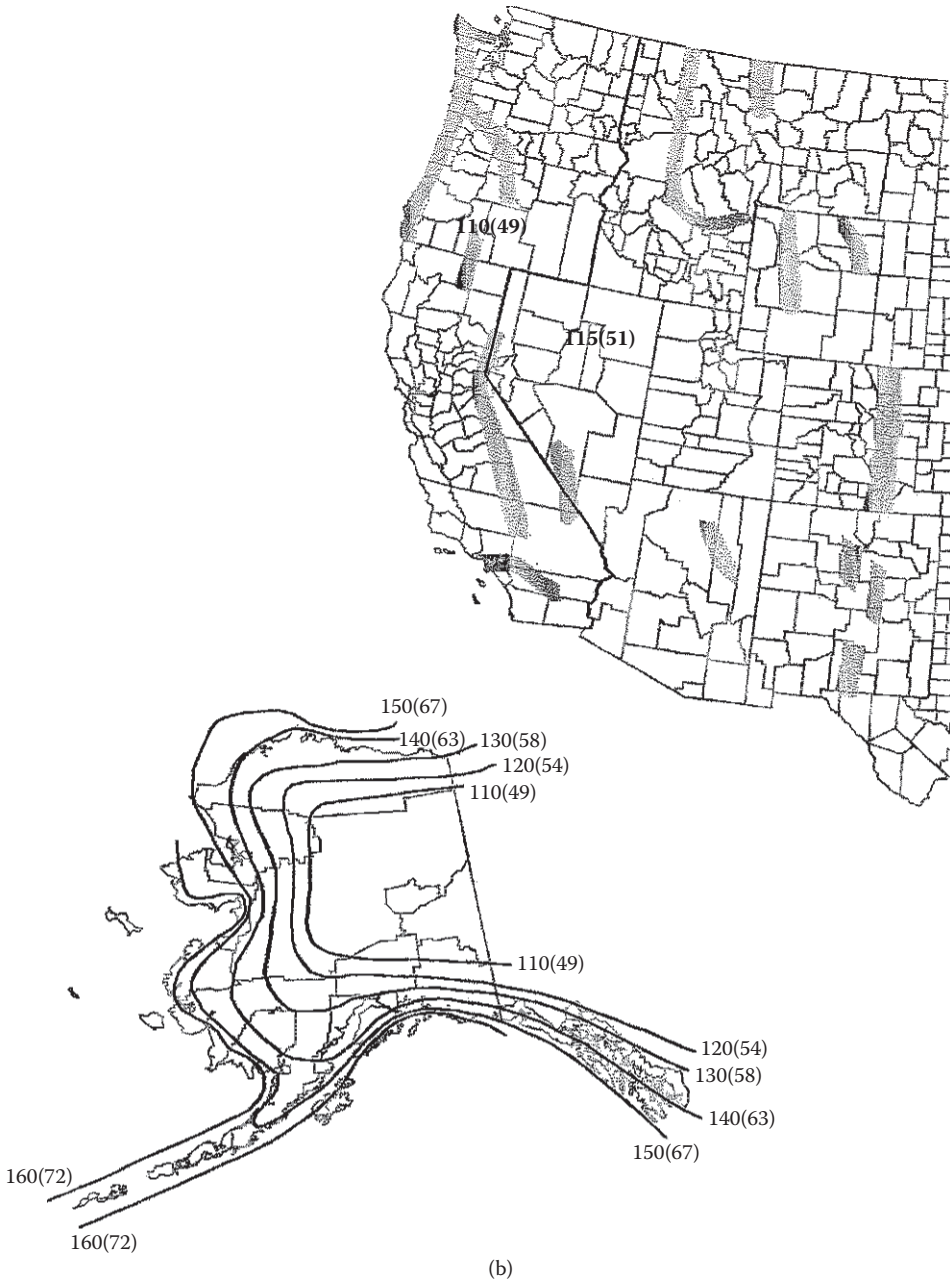


**FIGURE 4.1 (Continued)** Basic wind speed for risk category I buildings. (a) and (b) simply divides the country in two halves. *Notes:* 1. Values are nominal design 3-second gust wind speeds in miles per hour (m/s) at 33 ft. (10 m) above ground for exposure C category. 2. Linear interpolation between contours is permitted. 3. Islands and coastal areas outside the last contour shall use the last wind speed contour of the coastal area. 4. Mountainous terrain, gorges, ocean promontories, and special wind regions shall be examined for unusual wind conditions. 5. Wind speeds correspond to approximately a 15% probability of exceedance in 50 years (Annual Exceedance Probability = 0.00333, MRI = 300 years). (Courtesy of American Society of Civil Engineers.)



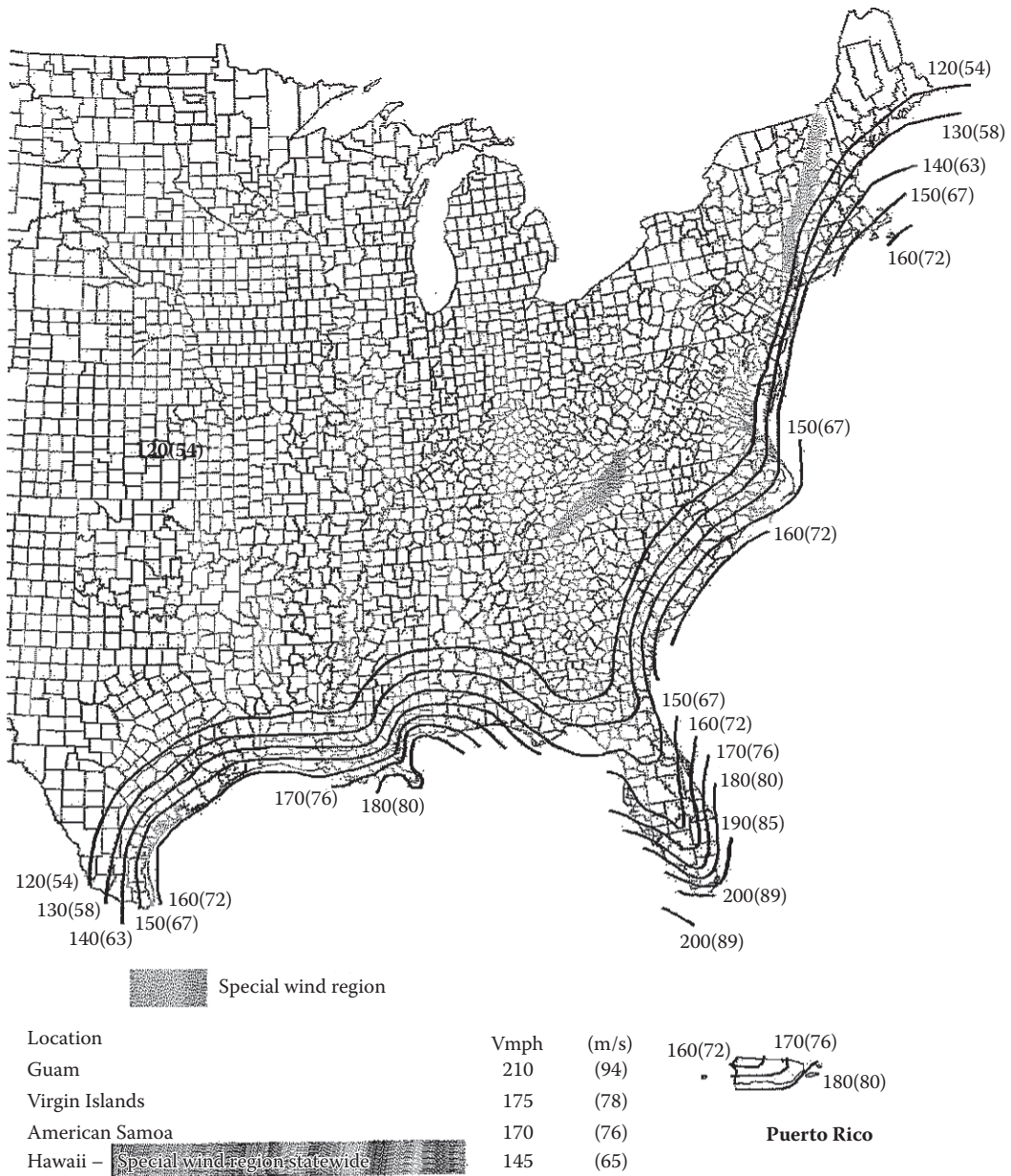
(a)

**FIGURE 4.2** Basic wind speed for risk category II buildings. (a) and (b) simply divides the country in two halves. *Notes:* 1. Values are nominal design 3-second gust wind speeds in miles per hour (m/s) at 33 ft. (10 m) above ground for exposure C category. 2. Linear interpolation between contours is permitted. 3. Islands and coastal areas outside the last contour shall use the last wind speed contour of the coastal area. 4. Mountainous terrain, gorges, ocean promontories, and special wind regions shall be examined for unusual wind conditions. 5. Wind speeds correspond to approximately a 7% probability of exceedance in 50 years (Annual Exceedance Probability = 0.00143, MRI = 700 years). (Courtesy of American Society of Civil Engineers.)



**FIGURE 4.2 (Continued)** Basic wind speed for risk category II buildings. (a) and (b) simply divides the country in two halves. *Notes:* 1. Values are nominal design 3-second gust wind speeds in miles per hour (m/s) at 33 ft. (10 m) above ground for exposure C category. 2. Linear interpolation between contours is permitted. 3. Islands and coastal areas outside the last contour shall use the last wind speed contour of the coastal area. 4. Mountainous terrain, gorges, ocean promontories, and special wind regions shall be examined for unusual wind conditions. 5. Wind speeds correspond to approximately a 7% probability of exceedance in 50 years (Annual Exceedance Probability = 0.00143, MRI = 700 years). (Courtesy of American Society of Civil Engineers.)





(a)

**FIGURE 4.3** Basic wind speed for risk category III and IV buildings. (a) and (b) simply divides the country in two halves. *Notes:* 1. Values are nominal design 3-second gust wind speeds in miles per hour (m/s) at 33 ft. (10 m) above ground for exposure C category. 2. Linear interpolation between contours is permitted. 3. Islands and coastal areas outside the last contour shall use the last wind speed contour of the coastal area. 4. Mountainous terrain, gorges, ocean promontories, and special wind regions shall be examined for unusual wind conditions. 5. Wind speeds correspond to approximately a 3% probability of exceedance in 50 years (Annual Exceedance Probability = 0.000588, MRI = 1700 years). (Courtesy of American Society of Civil Engineers.)



**FIGURE 4.3 (Continued)** Basic wind speed for risk category III and IV buildings. (a) and (b) simply divides the country in two halves. *Notes:* 1. Values are nominal design 3-second gust wind speeds in miles per hour (m/s) at 33 ft. (10 m) above ground for exposure C category. 2. Linear interpolation between contours is permitted. 3. Islands and coastal areas outside the last contour shall use the last wind speed contour of the coastal area. 4. Mountainous terrain, gorges, ocean promontories, and special wind regions shall be examined for unusual wind conditions. 5. Wind speeds correspond to approximately a 3% probability of exceedance in 50 years (Annual Exceedance Probability = 0.000588, MRI = 1700 years). (Courtesy of American Society of Civil Engineers.)

**TABLE 4.1**  
**Exposure Category for Wind Load**

Surface Roughness	Exposure Category
Urban and suburban areas, wooded areas, closely spaced dwellings	<i>B</i>
Scattered obstructions—flat open country, grasslands	<i>C</i>
Flat unobstructed areas, smooth mud and salt flats, water surfaces	<i>D</i>

**TABLE 4.2**  
**Adjustment Factor for Height and Exposure**

Mean Roof Height (ft.)	Exposure		
	<i>B</i>	<i>C</i>	<i>D</i>
15	1.00	1.21	1.47
20	1.00	1.29	1.55
25	1.00	1.35	1.61
30	1.00	1.40	1.66
35	1.05	1.45	1.70
40	1.09	1.49	1.74
45	1.12	1.53	1.78
50	1.16	1.56	1.81
55	1.19	1.59	1.84
60	1.22	1.62	1.87

6. The combined windward and leeward net wind pressure,  $p_s$ , is determined by the following simplified equation:

$$p_s = \lambda K_{zt} p_{s30} \quad (4.1)$$

where

$\lambda$  is adjustment factor for structure height and exposure (Tables 4.1 and 4.2)

$K_{zt}$  is topographic factor; for usual cases 1

$p_{s30}$  is simplified standard design wind pressure (Table 4.3)

The pressure  $p_s$  is the pressure that acts horizontally on the vertical and vertically on the horizontal projection of the structure surface. It represents the net pressure that algebraically sums up the external and internal pressures acting on a building surface. Furthermore in the case of MWFRS, for the horizontal pressures that act on the building envelope, the  $p_s$  combines the windward and leeward pressures.

The plus and minus signs signify the pressures acting toward and away, respectively, from the projected surface.

#### HORIZONTAL PRESSURE ZONES FOR MWFRS

The horizontal pressures acting on the vertical plane are separated into the following four pressure zones, as shown in Figure 4.4:

- A: End zone of wall
- B: End zone of (vertical projection) roof
- C: Interior zone of wall
- D: Interior zone of (vertical projection) roof

**TABLE 4.3**  
**Simplified Design Wind Pressure,  $p_{s30}$  (psf)**

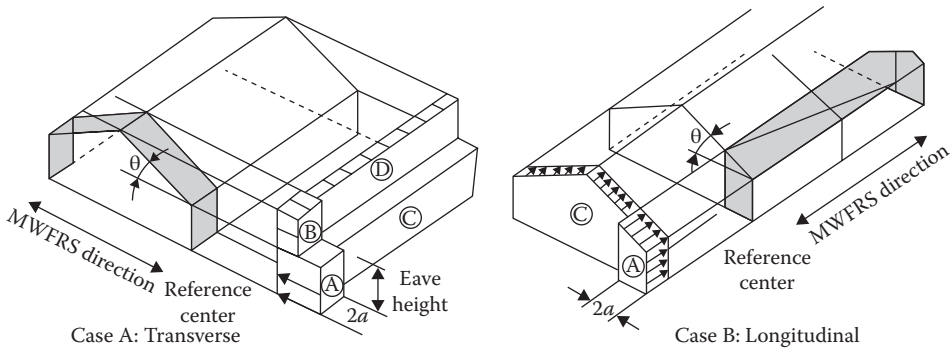
Basic Wind Speed (mph)	Roof Angle (degrees)	Load Case	Zones													
			Horizontal Pressures						Vertical Pressures						Overhangs	
			A	B	C	D	E	F	G	H	$E_{OH}$	$G_{OH}$				
110	0-5	1	19.2	-10.0	12.7	-5.9	-23.1	-13.1	-16.0	-10.1	-32.3	-25.3				
		1	21.6	-9.0	14.4	-5.2	-23.1	-14.1	-16.0	-10.8	-32.3	-25.3				
	10	1	24.1	-8.0	16.0	-4.6	-23.1	-15.1	-16.0	-11.5	-32.3	-25.3				
		1	26.6	-7.0	17.7	-3.9	-23.1	-16.0	-16.0	-12.2	-32.3	-25.3				
	25	1	24.1	3.9	17.4	4.0	-10.7	-14.6	-7.7	-11.7	-19.9	-17.0				
		2	—	—	—	—	-4.1	-7.9	-1.1	-5.1	—	—				
115	30-45	1	21.6	14.8	17.2	11.8	1.7	-13.1	0.6	-11.3	-7.6	-8.7				
		2	21.6	14.8	17.2	11.8	8.3	-6.5	7.2	-4.6	-7.6	-8.7				
	0-5	1	21.0	-10.9	13.9	-6.5	-25.2	-14.3	-17.5	-11.1	-35.3	-27.6				
		1	23.7	-9.8	15.7	-5.7	-25.2	-15.4	-17.5	-11.8	-35.3	-27.6				
	10	1	26.3	-8.7	17.5	-5.0	-25.2	-16.5	-17.5	-12.6	-35.3	-27.6				
		1	29.0	-7.7	19.4	-4.2	-25.2	-17.5	-17.5	-13.3	-35.3	-27.6				
25	1	26.3	4.2	19.1	4.3	-11.7	-15.9	-8.5	-12.8	-21.8	-18.5					
	2	—	—	—	—	-4.4	-8.7	-1.2	-5.5	—	—					
120	30-45	1	23.6	16.1	18.8	12.9	1.8	-14.3	0.6	-12.3	-8.3	-9.5				
		2	23.6	16.1	18.8	12.9	9.1	-7.1	7.9	-5.0	-8.3	-9.5				
	0-5	1	22.8	-11.9	15.1	-7.0	-27.4	-15.6	-19.1	-12.1	-38.4	-30.1				
		1	25.8	-10.7	17.1	-6.2	-27.4	-16.8	-19.1	-12.9	-38.4	-30.1				
	10	1	28.7	-9.5	19.1	-5.4	-27.4	-17.9	-19.1	-13.7	-38.4	-30.1				
		1	31.6	-8.3	21.1	-4.6	-27.4	-19.1	-19.1	-14.5	-38.4	-30.1				
25	1	28.6	4.6	20.7	4.7	-12.7	-17.3	-9.2	-13.9	-23.7	-20.2					
	2	—	—	—	—	-4.8	-9.4	-1.3	-6.0	—	—					
30-45	1	25.7	17.6	20.4	14.0	2.0	-15.6	0.7	-13.4	-9.0	-10.3					
	2	25.7	17.6	20.4	14.0	9.9	-7.7	8.6	-5.5	-9.0	-10.3					

130	1	0-5	26.8	-13.9	17.8	-8.2	-32.2	-18.3	-22.4	-14.2	-45.1	-35.3
	1	10	30.2	-12.5	20.1	-7.3	-32.2	-19.7	-22.4	-15.1	-45.1	-35.3
	1	15	33.7	-11.2	22.4	-6.4	-32.2	-21.0	-22.4	-16.1	-45.1	-35.3
	1	20	37.1	-9.8	24.7	-5.4	-32.2	-22.4	-22.4	-17.0	-45.1	-35.3
	1	25	33.6	5.4	24.3	5.5	-14.9	-20.4	-10.8	-16.4	-27.8	-23.7
	2		—	—	—	—	-5.7	-11.1	-1.5	-7.1	—	—
	1	30-45	30.1	20.6	24.0	16.5	2.3	-18.3	0.8	-15.7	-10.6	-12.1
	2		30.1	20.6	24.0	16.5	11.6	-9.0	10.0	-6.4	-10.6	-12.1
140	1	0-5	31.1	-16.1	20.6	-9.6	-37.3	-21.2	-26.0	-16.4	-52.3	-40.9
	1	10	35.1	-14.5	23.3	-8.5	-37.3	-22.8	-26.0	-17.5	-52.3	-40.9
	1	15	39.0	-12.9	26.0	-7.4	-37.3	-24.4	-26.0	-18.6	-52.3	-40.9
	1	20	43.0	-11.4	28.7	-6.3	-37.3	-26.0	-26.0	-19.7	-52.3	-40.9
	1	25	39.0	6.3	28.2	6.4	-17.3	-23.6	-12.5	-19.0	-32.3	-27.5
	2		—	—	—	—	-6.6	-12.8	-1.8	-8.2	—	—
	1	30-45	35.0	23.9	27.8	19.1	2.7	-21.2	0.9	-18.2	-12.3	-14.0
	2		35.0	23.9	27.8	19.1	13.4	-10.5	11.7	-7.5	-12.3	-14.0
150	1	0-5	35.7	-18.5	23.7	-11.0	-42.9	-24.4	-29.8	-18.9	-60.0	-47.0
	1	10	40.2	-16.7	26.8	-9.7	-42.9	-26.2	-29.8	-20.1	-60.0	-47.0
	1	15	44.8	-14.9	29.8	-8.5	-42.9	-28.0	-29.8	-21.4	-60.0	-47.0
	1	20	49.4	-13.0	32.9	-7.2	-42.9	-29.8	-29.8	-22.6	-60.0	-47.0
	1	25	44.8	7.2	32.4	7.4	-19.9	-27.1	-14.4	-21.8	-37.0	-31.6
	2		—	—	—	—	-7.5	-14.7	-2.1	-9.4	—	—
	1	30-45	40.1	27.4	31.9	22.0	3.1	-24.4	1.0	-20.9	-14.1	-16.1
	2		40.1	27.4	31.9	22.0	15.4	-12.0	13.4	-8.6	-14.1	-16.1
160	1	0-5	40.6	-21.1	26.9	-12.5	-48.8	-27.7	-34.0	-21.5	-68.3	-53.5
	1	10	45.8	-19.0	30.4	-11.1	-48.8	-29.8	-34.0	-22.9	-68.3	-53.5
	1	15	51.0	-16.9	34.0	-9.6	-48.8	-31.9	-34.0	-24.3	-68.3	-53.5
	1	20	56.2	-14.8	37.5	-8.2	-48.8	-34.0	-34.0	-25.8	-68.3	-53.5
	1	25	50.9	8.2	36.9	8.4	-22.6	-30.8	-16.4	-24.8	-42.1	-35.9
	2		—	—	—	—	-8.6	-16.8	-2.3	-10.7	—	—
	1	30-45	45.7	31.2	36.3	25.0	3.5	-27.7	1.2	-23.8	-16.0	-18.3
	1		45.7	31.2	36.3	25.0	17.6	-13.7	15.2	-9.8	-16.0	-18.3

(Continued)

**TABLE 4.3 (Continued)**  
**Simplified Design Wind Pressure,  $p_{s30}$  (psf)**

Basic Wind Speed (mph)	Roof Angle (degrees)	Load Case	Zones													
			Horizontal Pressures						Vertical Pressures						Overhangs	
			A	B	C	D	E	F	G	H	$E_{OH}$	$G_{OH}$				
180	0-5	1	51.4	-26.7	34.1	-15.8	-61.7	-35.1	-43.0	-27.2	-86.4	-67.7				
	10	1	58.0	-24.0	38.5	-14.0	-61.7	-37.7	-43.0	-29.0	-86.4	-67.7				
	15	1	64.5	-21.4	43.0	-12.2	-61.7	-40.3	-43.0	-30.8	-86.4	-67.7				
	20	1	71.1	-18.8	47.4	-10.4	-61.7	-43.0	-43.0	-32.6	-86.4	-67.7				
	25	1	64.5	10.4	46.7	10.6	-28.6	-39.0	-20.7	-31.4	-53.3	-45.4				
		2	—	—	—	—	-10.9	-21.2	-3.0	-13.6	—	—				
200	30-45	1	57.8	39.5	45.9	31.6	4.4	-35.1	1.5	-30.1	-20.3	-23.2				
		2	57.8	39.5	45.9	31.6	22.2	-17.3	19.3	-12.3	-20.3	-23.2				
	0-5	1	63.4	-32.9	42.1	-19.5	-76.2	-43.3	-53.1	-33.5	-106.7	-83.5				
	10	1	71.5	-29.7	47.6	-17.3	-76.2	-46.5	-53.1	-35.8	-106.7	-83.5				
	15	1	79.7	-26.4	53.1	-15.0	-76.2	-49.8	-53.1	-38.0	-106.7	-83.5				
	20	1	87.8	-23.2	58.5	-12.8	-76.2	-53.1	-53.1	-40.2	-106.7	-83.5				
2	25	1	79.6	12.8	57.6	13.1	-35.4	-48.2	-25.6	-38.7	-65.9	-56.1				
		2	—	—	—	—	-13.4	-26.2	-3.7	-16.8	—	—				
	30-45	1	71.3	48.8	56.7	39.0	5.5	-43.3	1.8	-37.2	-25.0	-28.7				
		2	71.3	48.8	56.7	39.0	27.4	-21.3	23.8	-15.2	-25.0	-28.7				



**FIGURE 4.4** Horizontal pressure zones.

The dimension of the end zones A and B are taken equal to  $2a$ , where the value of  $a$  is smaller than the following two values:

1. 0.1 times the least horizontal dimension
2. 0.4 times the roof height,  $h$

The height,  $h$ , is the mean height of roof from the ground. For roof angle  $<10^\circ$ , it is the height to the eave.

If the pressure in zone B or D is negative, treat it as zero in computing the total horizontal force.

For Case B in Figure 4.4, wind acting in the longitudinal direction (wind acting on width), use  $\theta = 0$  and zones B and D do not exist.

### VERTICAL PRESSURE ZONES FOR MWFRS

The vertical pressures on the roof are likewise separated into the following four zones, as shown in Figure 4.5.

- E: End zone of (horizontal projection) windward roof
- F: End zone of (horizontal projection) leeward roof
- G: Interior zone of (horizontal projection) windward roof
- H: Interior zone of (horizontal projection) leeward roof

Where the end zones E and G fall on a roof overhang, the pressure values under the columns  $E_{OH}$  and  $G_{OH}$  in Table 4.3 are used for the windward side. For the leeward side, the basic values are used.

The dimension of the end zones E and F is taken to be the horizontal distance from edge to ridge and equal to  $2a$  in windward direction, as shown in Figure 4.5 for both Case A, transverse direction, and Case B, longitudinal direction. For the longitudinal wind direction, roof angle  $= 0$  is used.

### MINIMUM PRESSURE FOR MWFRS

The minimum wind load computed for MWFRS is based on pressures of 16 psf for zones A and B and pressures of 8 psf for zones C and D, while assuming the pressures for zones E, F, G, and H are equal to zero.

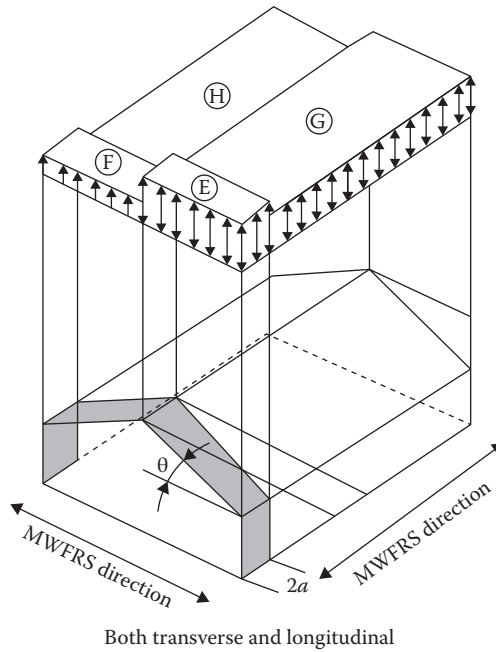


FIGURE 4.5 Vertical pressure zones.

**Example 4.1**

A two-story essential facility shown in Figure 4.6 is an enclosed wood-frame building located in Seattle, Washington. Determine the design wind pressures for MWFRS in both principal directions of the building and the forces acting on the transverse section of the building. The wall studs and roof rafters are 16 in. on center.  $K_{zt} = 1.0$ .

**SOLUTION**

- I. Design parameters
  1. Roof slope,  $\theta = 14^\circ$
  2.  $h_{mean} = 22 + \frac{6.25}{2} = 25.13$  ft.
  3. End zone dimension,  $a$ , smaller than
    - a.  $0.4 h_{mean} = 0.4 (25.13) = 10$  ft.
    - b.  $0.1 \text{ width} = 0.1(50) = 5$  ft. ← controls
  4. Length of end zone =  $2a = 10$  ft.

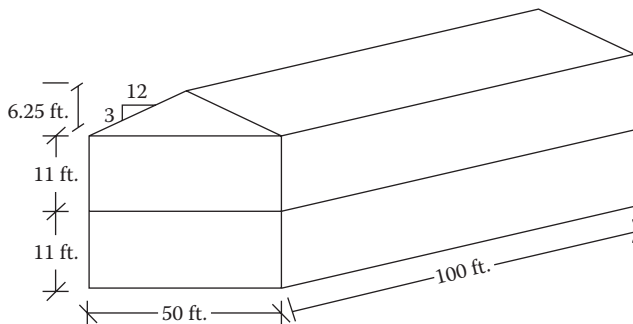


FIGURE 4.6 Two-story framed building.



5. Basic wind speed,  $V = 115$  mph
  6. Exposure category =  $B$
  7.  $\lambda$  from Table 4.3 up to 30 ft. = 1.0
  8.  $K_{zt} = 1.00$  (given)
  9.  $p_s = \lambda K_{zt} p_{s30} = (1)(1)p_{s30} = p_{s30}$
- II. Case A: For transverse wind direction
- A.1 Horizontal wind pressure on wall and roof projection

Zone	Pressure (psf) (Table 4.3)			$p_s = p_{s30}$ (psf)
	Roof Angle = 10°	Roof Angle = 15°	Interpolated for 14°	
A. End zone wall	23.7	26.3	25.78	25.78
B. End zone roof	-9.8	-8.7	-8.92	-8.92
C. Interior wall	15.7	17.5	17.14	17.14
D. Interior roof	-5.7	-5.0	-5.14	-5.14

Note: These pressures are shown in the section view in Figure 4.7a.

A.2 Horizontal force at the roof level

Location	Zone	Tributary			Pressure (psf)	Load (lb)
		Height (ft.)	Width (ft.)	Area (ft. <sup>2</sup> )		
End	A	11 <sup>a</sup>	$2a = 10$	110	25.78	2,836
	B	6.25	10	62.5	-8.92 → 0	0
Interior	C	11	$L - 2a = 90$	990	17.14	16,969
	D	6.25	90	562.5	-5.14 → 0	0
Total						19,805

Note: Taking pressures in zones B and D to be zero.

<sup>a</sup> It is also a practice to take 1/2 of the floor height for each level. In such a case, the wind force on the 1/2 of the first floor height from the ground is not applied.

A.3 Horizontal force at the second floor level

Location	Zone	Tributary			Pressure (psf)	Load (lb)
		Height (ft.)	Width (ft.)	Area (ft. <sup>2</sup> )		
End	A	11	10	110	25.78	2,836
Interior	C	11	90	990	17.14	16,969
Total						19,805

Total horizontal force is 39,610. The application of the forces is shown in Figure 4.7b.

B.1 Vertical wind pressure on the roof

Zone	Pressure (psf) (Table 4.3)			$p_s = p_{s30}$ (psf)
	Roof Angle = 10°	Roof Angle = 15°	Interpolated to 14°	
E: End, windward	-25.2	-25.2	-25.2	-25.2
F: End, leeward	-15.4	-16.5	-16.28	-16.28
G: Interior, windward	-17.5	-17.5	-17.5	-17.5
H: Interior, leeward	-11.6	-12.6	-12.4	-12.4

Note: The pressures are shown in the sectional view in Figure 4.8a.

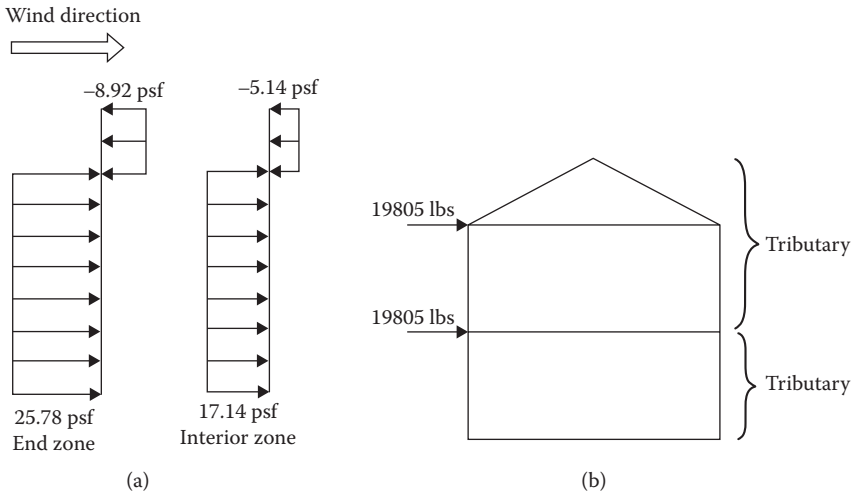


FIGURE 4.7 (a) Horizontal pressure distribution and (b) horizontal force:transverse wind.

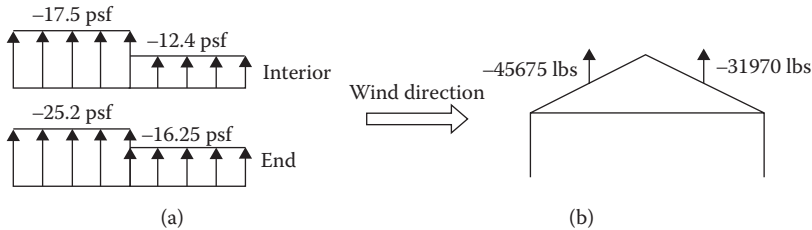


FIGURE 4.8 (a) Vertical pressure distribution on roof and (b) vertical force on roof:transverse wind.

B.2 Vertical force on the roof

Zone		Tributary			Pressure (psf)	Load (lb)
		Length (ft.)	Width (ft.)	Area (ft. <sup>2</sup> )		
Windward	E: End	25	2a = 10	250	-25.2	-6,300
	G: Interior	25	L - 2a = 90	2250	-17.5	-39,375
	Total					-45,675
Leeward	F: End	25	10	250	-16.28	-4,070
	H: Interior	25	90	2250	-12.4	-27,900
	Total					-31,970

Note: The application of vertical forces is shown in Figure 4.8b.

- C. Minimum force on MWFRS by transverse wind  
The minimum pressure is 16 psf acting on the vertical projection of wall and 8 psf on vertical projection of roof. Thus,  
Minimum wind force =  $[16(22) + 8(6.25)] \times 100 = 40,200$  lb
- D. Applicable wind force  
The following two cases should be considered for maximum effect:
  1. The combined A.2, A.3, and B.2
  2. Minimum force C
- III. Case B: For longitudinal wind direction
  - A.1 Horizontal wind pressures on wall  
Zones B and D do not exist. Using  $\theta = 0$ , pressure on zone A = 21.0 psf and pressure on zone C = 13.9 psf from Table 4.3.

A.2 Horizontal force at the roof level

From Figure 4.9,

$$\text{Tributary area for end zone A} = \frac{1}{2}(11 + 13.5)(10) = 122.5 \text{ ft.}^2$$

$$\begin{aligned} \text{Tributary area for interior zone C} &= \frac{1}{2}(13.5 + 17.25)(15) + \frac{1}{2}(17.25 + 11)(25) \\ &= 230.63 + 353.12 = 583.75 \text{ ft.}^2 \end{aligned}$$

Zone	Tributary Area (ft. <sup>2</sup> )	Pressure (psf)	Load <sup>a</sup> (lb)
A	122.5	21.0	2,573
C	583.75	13.9	8,114
Total			10,687

<sup>a</sup> The centroids of area are different but the force is assumed to be acting at roof level.

A.3 Horizontal force at the second floor level

$$\text{Tributary area for end zone A} = 11 \times 10 = 110 \text{ ft.}^2$$

$$\text{Tributary area for interior zone C} = 11 \times 40 = 440 \text{ ft.}^2$$

Zone	Tributary Area (ft. <sup>2</sup> )	Pressure (psf)	Load (lb)
A	110	21.0	2310
C	440	13.9	6116
Total			8426

Note: The application of forces is shown in the sectional view in Figure 4.9.

B.1 Vertical wind pressure on the roof (longitudinal case)

Use  $\theta = 0$

Zone	$p_{s30}$ (psf)	$p_s = p_{s30}$
End E	-25.2	-25.2
End F	-14.3	-14.3
Interior G	-17.5	-17.5
Interior H	-11.1	-11.1

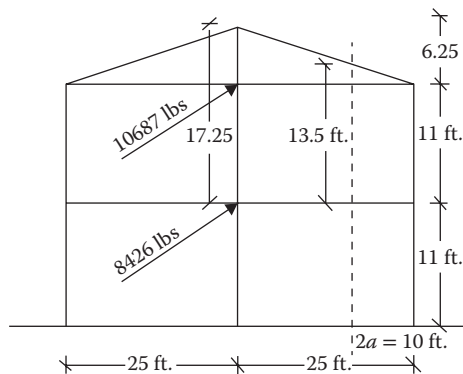


FIGURE 4.9 Horizontal wind force on wall and roof projection: longitudinal wind.

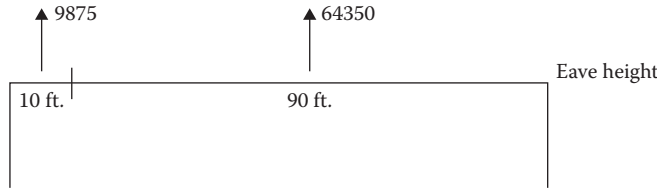


FIGURE 4.10 Force on roof:longitudinal wind.

B.2 Vertical force on the roof

Zone		Tributary			Pressure (psf)	Load (lb)
		Length (ft.)	Width (ft.)	Area (ft. <sup>2</sup> )		
End	E	2a = 10	B/2 = 25	250	-25.2	-6,300
	F	2a = 10	25	250	-14.3	-3,575
	Total					-9,875
Interior	G	L -2a = 90	25	2250	-17.5	-39,375
	H	90	25	2250	-11.1	-24,975
	Total					-64,350

*Note:* The application of forces is shown in Figure 4.10.

PROCEDURES FOR COMPONENTS AND CLADDING

ASCE 7-10 stipulates that when the tributary area is greater than 700 ft.<sup>2</sup>, the C and C elements can be designed using the provisions of MWFRS. Chapter 30 of ASCE 7-10 specifies procedures for C and C; these are parallel to the procedures of MWFRS. Two analytical procedures—one for high-rise buildings and one for low-rise buildings—use equations similar to the analytical procedures of MWFRS. Two simplified procedures—one for regular-shaped enclosed buildings up to 160 ft. in height and one for regular-shaped enclosed low-rise buildings—determine wind pressures directly from tables. ASCE 7-10 also covers the C and C for open buildings and appurtenances.

SIMPLIFIED PROCEDURE FOR COMPONENTS AND CLADDING FOR LOW-RISE BUILDINGS

The C and C cover the individual structural elements that directly support a tributary area against the wind force. The conditions and the steps of the procedure are essentially similar to the MWFRS. The pressure, however, acts normal to each surface, that is, horizontal on the wall and perpendicular to the roof. The following similar equation is used to determine the wind pressure. The adjustment factor, λ, and the topographic factor,  $K_{zt}$ , are determined from the similar considerations as for MWFRS:

$$p_{net} = \lambda K_{zt} p_{net30} \tag{4.2}$$

where

λ is adjustment factor for structure height and exposure (Tables 4.1 and 4.2)

$K_{zt}$  is topographic factor

$p_{net30}$  is simplified standard design wind pressure (Table 4.4)

However, the pressures  $p_{net30}$  are different from  $p_{s30}$ . Besides the basic wind speed, the pressures are a function of the roof angle, the effective wind area supported by the element, and the zone of the structure surface.  $p_{net}$  represents the net pressures, which are the algebraic summation of the internal and external pressures acting normal to the surface of the C and C.

**TABLE 4.4**  
**Net Design Wind Pressure,  $p_{net30}$  (psf)**

Roof	Zone	Effective Wind Area (sf)	Basic Wind Speed $V$ (mph)																	
			110	115	120	130	140	150	160	180	200									
0°-7°	1	10	8.9	-21.8	9.7	-23.8	10.5	-25.9	12.4	-30.4	14.3	-35.3	16.5	-40.5	18.7	-46.1	23.7	-58.3	29.3	-72.0
	1	20	8.3	-21.2	9.1	-23.2	9.9	-25.2	11.6	-29.6	13.4	-34.4	15.4	-39.4	17.6	-44.9	22.2	-56.8	27.4	-70.1
	1	50	7.6	-20.5	8.3	-22.4	9.0	-24.4	10.6	-28.6	12.3	-33.2	14.1	-38.1	16.0	-43.3	20.3	-54.8	25.0	-67.7
	1	100	7.0	-19.9	7.7	-21.8	8.3	-23.7	9.8	-27.8	11.4	-32.3	13.0	-37.0	14.8	-42.1	18.8	-53.3	23.2	-65.9
	2	10	8.9	-36.5	9.7	-39.9	10.5	-43.5	12.4	-51.0	14.3	-59.2	16.5	-67.9	18.7	-77.3	23.7	-97.8	29.3	-120.7
	2	20	8.3	-32.6	9.1	-35.7	9.9	-38.8	11.6	-45.6	13.4	-52.9	15.4	-60.7	17.6	-69.0	22.2	-87.4	27.4	-107.9
	2	50	7.6	-27.5	8.3	-30.1	9.0	-32.7	10.6	-38.4	12.3	-44.5	14.1	-51.1	16.0	-58.2	20.3	-73.6	25.0	-90.9
	2	100	7.0	-23.6	7.7	-25.8	8.3	-28.1	9.8	-33.0	11.4	-38.2	13.0	-43.9	14.8	-50.0	18.8	-63.2	23.2	-78.1
	3	10	8.9	-55.0	9.7	-60.1	10.5	-65.4	12.4	-76.8	14.3	-89.0	16.5	-102.2	18.7	-116.3	23.7	-147.2	29.3	-181.7
	3	20	8.3	-45.5	9.1	-49.8	9.9	-54.2	11.6	-63.6	13.4	-73.8	15.4	-84.7	17.6	-96.3	22.2	-121.9	27.4	-150.5
	3	50	7.6	-33.1	8.3	-36.1	9.0	-39.3	10.6	-46.2	12.3	-53.5	14.1	-61.5	16.0	-69.9	20.3	-88.5	25.0	-109.3
	3	100	7.0	-23.6	7.7	-25.8	8.3	-28.1	9.8	-33.0	11.4	-38.2	13.0	-43.9	14.8	-50.0	18.8	-63.2	23.2	-78.1
>7°-27°	1	10	12.5	-19.9	13.7	-21.8	14.9	-23.7	17.5	-27.8	20.3	-32.3	23.3	-37.0	26.5	-42.1	33.6	-53.3	41.5	-65.9
	1	20	11.4	-19.4	12.5	-21.2	13.6	-23.0	16.0	-27.0	18.5	-31.4	21.3	-36.0	24.2	-41.0	30.6	-51.9	37.8	-64.0
	1	50	10.0	-18.6	10.9	-20.4	11.9	-22.2	13.9	-26.0	16.1	-30.2	18.5	-34.6	21.1	-39.4	26.7	-49.9	32.9	-61.6
	1	100	8.9	-18.1	9.7	-19.8	10.5	-21.5	12.4	-25.2	14.3	-29.3	16.5	-33.6	18.7	-38.2	23.7	-48.4	29.3	-59.8
	2	10	12.5	-34.7	13.7	-37.9	14.9	-41.3	17.5	-48.4	20.3	-56.2	23.3	-64.5	26.5	-73.4	33.6	-92.9	41.5	-114.6
	2	20	11.4	-31.9	12.5	-34.9	13.6	-38.0	16.0	-44.6	18.5	-51.7	21.3	-59.3	24.2	-67.5	30.6	-85.4	37.8	-105.5
	2	50	10.0	-28.2	10.9	-30.9	11.9	-33.6	13.9	-39.4	16.1	-45.7	18.5	-52.5	21.1	-59.7	26.7	-75.6	32.9	-93.3
	2	100	8.9	-25.5	9.7	-27.8	10.5	-30.3	12.4	-35.6	14.3	-41.2	16.5	-47.3	18.7	-53.9	23.7	-68.2	29.3	-84.2
	3	10	12.5	-51.3	13.7	-56.0	14.9	-61.0	17.5	-71.6	20.3	-83.1	23.3	-95.4	26.5	-108.5	33.6	-137.3	41.5	-169.5
	3	20	11.4	-47.9	12.5	-52.4	13.6	-57.1	16.0	-67.0	18.5	-77.7	21.3	-89.2	24.2	-101.4	30.6	-128.4	37.8	-158.5
	3	50	10.0	-43.5	10.9	-47.6	11.9	-51.8	13.9	-60.8	16.1	-70.5	18.5	-81.0	21.1	-92.1	26.7	-116.6	32.9	-143.9
	3	100	8.9	-40.2	9.7	-44.0	10.5	-47.9	12.4	-56.2	14.3	-65.1	16.5	-74.8	18.7	-85.1	23.7	-107.7	29.3	-132.9

(Continued)

**TABLE 4.4 (Continued)**  
**Net Design Wind Pressure,  $p_{net30}$  (psf)**

Zone	Effective Wind Area (sf)	Basic Wind Speed $V$ (mph)																	
		110	115	120	130	140	150	160	180	200									
Roof >27°-45°	10	19.9	-21.8	21.8	-23.8	23.7	-25.9	27.8	-30.4	32.3	-35.3	37.0	-40.5	42.1	-46.1	53.3	-58.3	65.9	-72.0
	20	19.4	-20.7	21.2	-22.6	23.0	-24.6	27.0	-28.9	31.4	-33.5	36.0	-38.4	41.0	-43.7	51.9	-55.3	64.0	-68.3
	50	18.6	-19.2	20.4	-21.0	22.2	-22.8	26.0	-26.8	30.2	-31.1	34.6	-35.7	39.4	-40.6	49.9	-51.4	61.6	-63.4
	100	18.1	-18.1	19.8	-19.8	21.5	-21.5	25.2	-25.2	29.3	-29.3	33.6	-33.6	38.2	-38.2	48.4	-48.4	59.8	-59.8
	2	19.9	-25.5	21.8	-27.8	23.7	-30.3	27.8	-35.6	32.3	-41.2	37.0	-47.3	42.1	-53.9	53.3	-68.2	65.9	-84.2
	2	19.4	-24.3	21.2	-26.6	23.0	-29.0	27.0	-34.0	31.4	-39.4	36.0	-45.3	41.0	-51.5	51.9	-65.2	64.0	-80.5
	2	18.6	-22.9	20.4	-25.0	22.2	-27.2	26.0	-32.0	30.2	-37.1	34.6	-42.5	39.4	-48.4	49.9	-61.3	61.6	-75.6
	2	18.1	-21.8	19.8	-23.8	21.5	-25.9	25.2	-30.4	29.3	-35.3	33.6	-40.5	38.2	-46.1	48.4	-58.3	59.8	-72.0
	3	19.9	-25.5	21.8	-27.8	23.7	-30.3	27.8	-35.6	32.3	-41.2	37.0	-47.3	42.1	-53.9	53.3	-68.2	65.9	-84.2
	3	19.4	-24.3	21.2	-26.6	23.0	-29.0	27.0	-34.0	31.4	-39.4	36.0	-45.3	41.0	-51.5	51.9	-65.2	64.0	-80.5
	3	18.6	-22.9	20.4	-25.0	22.2	-27.2	26.0	-32.0	30.2	-37.1	34.6	-42.5	39.4	-48.4	49.9	-61.3	61.6	-75.6
	3	18.1	-21.8	19.8	-23.8	21.5	-25.9	25.2	-30.4	29.3	-35.3	33.6	-40.5	38.2	-46.1	48.4	-58.3	59.8	-72.0
Wall	10	21.8	-23.6	23.8	-25.8	25.9	-28.1	30.4	-33.0	35.3	-38.2	40.5	-43.9	46.1	-50.0	58.3	-63.2	72.0	-78.1
	20	20.8	-22.6	22.7	-24.7	24.7	-26.9	29.0	-31.6	33.7	-36.7	38.7	-42.1	44.0	-47.9	55.7	-60.6	68.7	-74.8
	4	19.5	-21.3	21.3	-23.3	23.2	-25.4	27.2	-29.8	31.6	-34.6	36.2	-39.7	41.2	-45.1	52.2	-57.1	64.4	-70.5
	4	18.5	-20.4	20.2	-22.2	22.0	-24.2	25.9	-28.4	30.0	-33.0	34.4	-37.8	39.2	-43.1	49.6	-54.5	61.2	-67.3
	4	16.2	-18.1	17.7	-19.8	19.3	-21.5	22.7	-25.2	26.3	-29.3	30.2	-33.6	34.3	-38.2	43.5	-48.4	53.7	-59.8
	5	21.8	-29.1	23.8	-31.9	25.9	-34.7	30.4	-40.7	35.3	-47.2	40.5	-54.2	46.1	-61.7	58.3	-78.0	72.0	-96.3
	5	20.8	-27.2	22.7	-29.7	24.7	-32.4	29.0	-38.0	33.7	-44.0	38.7	-50.5	44.0	-57.5	55.7	-72.8	68.7	-89.9
	5	19.5	-24.6	21.3	-26.9	23.2	-29.3	27.2	-34.3	31.6	-39.8	36.2	-45.7	41.2	-52.0	52.2	-65.8	64.4	-81.3
	5	18.5	-22.6	20.2	-24.7	22.0	-26.9	25.9	-31.6	30.0	-36.7	34.4	-42.1	39.2	-47.9	49.6	-60.6	61.2	-74.8
	5	16.2	-18.1	17.7	-19.8	19.3	-21.5	22.7	-25.2	26.3	-29.3	30.2	-33.6	34.3	-38.2	43.5	-48.4	53.7	-59.8

*Note:* For effective areas between those given above the load may be interpolated, otherwise use the load associated with the lower effective area.

The effective area is the tributary area of an element but need not be lesser than the span length multiplied by the width equal to one-third of the span length, that is,  $A = L^2/3$ .

Table 4.4, reproduced from ASCE 7-10, lists  $p_{net30}$  values for effective wind areas of 10, 20, 50, and 100 ft.<sup>2</sup> for roof and additionally 500 ft.<sup>2</sup> for wall. A roof element having an effective area in excess of 100 ft.<sup>2</sup> should use pressures corresponding to an area of 100 ft.<sup>2</sup> Similarly, a wall element supporting an area in excess of 500 ft.<sup>2</sup> should use pressures corresponding to 500 ft.<sup>2</sup> A linear interpolation is permitted for intermediate areas. Table 4.5 lists  $p_{net30}$  values for roof overhang.

The following zones shown in Figure 4.11 have been identified for the C and C.

The dimension  $a$  is smaller than the following two values:

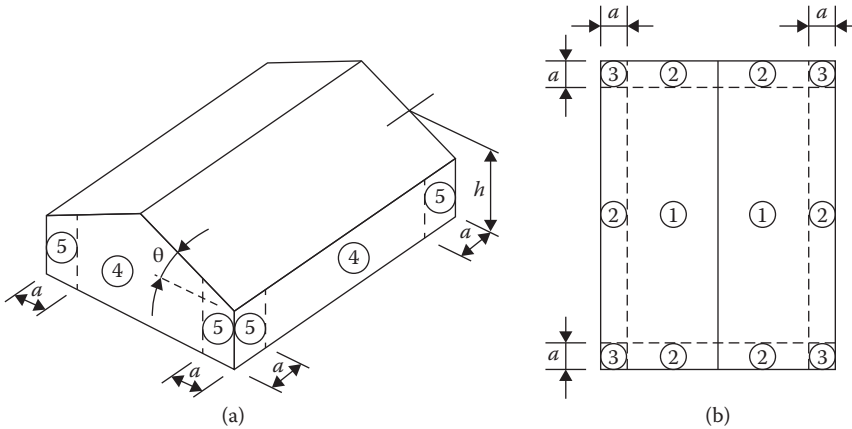
1. 0.4 times the mean height to roof,  $h_{mean}$
2. 0.1 times the smaller horizontal dimension

But, the value of  $a$  should not be less than the following:

1. 0.04 times the smaller horizontal dimension
2. 3 ft.

**TABLE 4.5**  
**Roof Overhang Net Design Wind Pressure,  $p_{net30}$  (psf)**

	Zone	Effective Wind Area (sf)	Basic Wind Speed $V$ (mph)							
			110	115	130	140	150	160	180	200
Roof 0°–7°	2	10	-31.4	-34.3	-43.8	-50.8	-58.3	-66.3	-84.0	-103.7
	2	20	-30.8	-33.7	-43.0	-49.9	-57.3	-65.2	-82.5	-101.8
	2	50	-30.1	-32.9	-42.0	-48.7	-55.9	-63.6	-80.5	-99.4
	2	100	-29.5	-32.3	-41.2	-47.8	-54.9	-62.4	-79.0	-97.6
	3	10	-51.6	-56.5	-72.1	-83.7	-96.0	-109.3	-138.3	-170.7
	3	20	-40.5	-44.3	-56.6	-65.7	-75.4	-85.8	-108.6	-134.0
	3	50	-25.9	-28.3	-36.1	-41.9	-48.1	-54.7	-69.3	-85.5
	3	100	-14.8	-16.1	-20.6	-23.9	-27.4	-31.2	-39.5	-48.8
Roof >7°–27°	2	10	-40.6	-44.4	-56.7	-65.7	-75.5	-85.9	-108.7	-134.2
	2	20	-40.6	-44.4	-56.7	-65.7	-75.5	-85.9	-108.7	-134.2
	2	50	-40.6	-44.4	-56.7	-65.7	-75.5	-85.9	-108.7	-134.2
	2	100	-40.6	-44.4	-56.7	-65.7	-75.5	-85.9	-108.7	-134.2
	3	10	-68.3	-74.6	-95.3	-110.6	-126.9	-144.4	-182.8	-225.6
	3	20	-61.6	-67.3	-86.0	-99.8	-114.5	-130.3	-164.9	-203.6
	3	50	-52.8	-57.7	-73.7	-85.5	-98.1	-111.7	-141.3	-174.5
	3	100	-46.1	-50.4	-64.4	-74.7	-85.8	-97.6	-123.5	-152.4
Roof >27°–45°	2	10	-36.9	-40.3	-51.5	-59.8	-68.6	-78.1	-98.8	-122.0
	2	20	-35.8	-39.1	-50.0	-58.0	-66.5	-75.7	-95.8	-118.3
	2	50	-34.3	-37.5	-47.9	-55.6	-63.8	-72.6	-91.9	-113.4
	2	100	-33.2	-36.3	-46.4	-53.8	-61.7	-70.2	-88.9	-109.8
	3	10	-36.9	-40.3	-51.5	-59.8	-68.6	-78.1	-98.8	-122.0
	3	20	-35.8	-39.1	-50.0	-58.0	-66.5	-75.7	-95.8	-118.3
	3	50	-34.3	-37.5	-47.9	-55.6	-63.8	-72.6	-91.9	-113.4
	3	100	-33.2	-36.3	-46.4	-53.8	-61.7	-70.2	-88.9	-109.8



End zones		Interior zones		Corner zones	
Wall	5	Wall	4		
Roof	2	Roof	1	Roof	3

FIGURE 4.11 Zones for components and cladding: (a) elevation and (b) plan.

There are two values of the net pressure that act on each element: a positive pressure acting inward (toward the surface) and a negative pressure acting outward (away from the surface). The two pressures must be considered separately for each element.

**MINIMUM PRESSURES FOR COMPONENTS AND CLADDING**

The positive pressure,  $p_{net}$ , should not be less than +16 psf and the negative pressure should not be less than -16 psf.

**Example 4.2**

Determine design wind pressures and forces for the studs and rafters of Example 4.1.

**SOLUTION**

A. Parameters

1.  $\theta = 14^\circ$
2.  $a = 5$  ft. (from Example 4.1), which is more than (1)  $0.04 (50) = 2$  ft. and (2) 3 ft.
3.  $p_{net} = p_{net30}$  (from Example 4.1)

B. Wind pressures on studs (wall) at each floor level

1. Effective area

$$A = L \times W = 11 \times \frac{16}{12} = 14.7 \text{ ft.}^2$$

$$A_{min} = \frac{L^2}{3} = \frac{(11)^2}{3} = 40.3 \text{ ft.}^2$$

2. Net wall pressures for  $V = 115$  mph

Zone	$p_{net30}$ at Interpolated		$p_{net} = p_{net30}$ (psf)	
	Effective Area	40.3 ft. <sup>2</sup> (psf)		
End: 5	21.75	-27.80	21.75	-27.80
Interior: 4	21.75	-23.75	21.75	-23.75



C. Wind forces on studs

C.1 On end studs that have higher pressures

1. Positive  $W = p_{net}$  (tributary area\*)

$$= 21.75 (14.7) = 319.73 \text{ lb (inward)}$$

2. Negative  $W = p_{net}$  (tributary area)

$$= -27.80 (14.7) = -408.66 \text{ lb (outward)}$$

These are shown in Figure 4.12.

D. Wind pressures on rafters (roof)

1. Length of rafter =  $\frac{25}{\cos 14^\circ} = 25.76 \text{ ft.}$
2.  $A = (25.76) \left( \frac{16}{12} \right) = 34.35 \text{ ft.}^2$
3.  $A_{min} = \frac{L^2}{3} = \frac{(25.76)^2}{3} = 221 \text{ ft.}^2$ , use  $100 \text{ ft.}^2$
4. Net roof pressures at  $\theta$  between  $7^\circ$  and  $27^\circ$

Zone	$p_{net30}$ at 100 ft. <sup>2</sup> (psf)		$p_{net} = p_{net30}$ (psf)	
Corner 3	9.7	-44.0	9.7 <sup>a</sup>	-44.0
End 2	9.7	-27.8	9.7 <sup>a</sup>	-27.8
Interior 1	9.7	-19.8	9.7 <sup>a</sup>	-19.8

<sup>a</sup> Use a minimum of 16 psf.

E. Wind forces on rafters

E.1 On end rafters

1. Positive  $W = p_{net}$  (tributary area) =  $16 (34.35) = 549.6 \text{ lb (inward)}$
2. Negative  $W = p_{net}$  (tributary area) =  $-27.8(34.35) = -954.9 \text{ lb (outward)}$
3. These are shown in Figure 4.13.

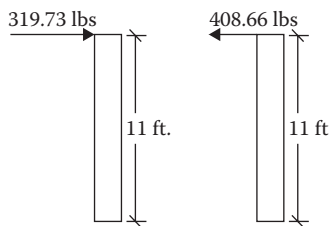


FIGURE 4.12 Wind force on end studs.

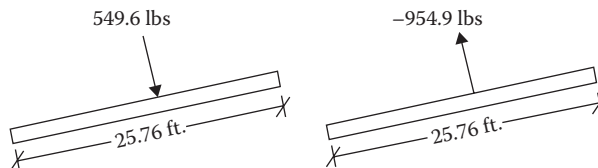
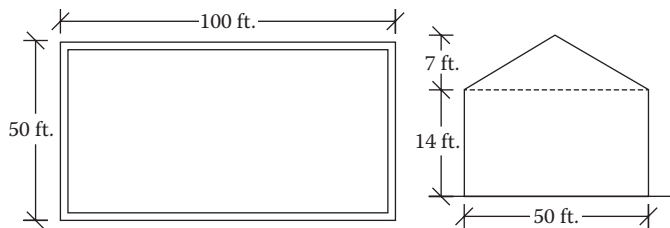


FIGURE 4.13 Wind force on end rafters.

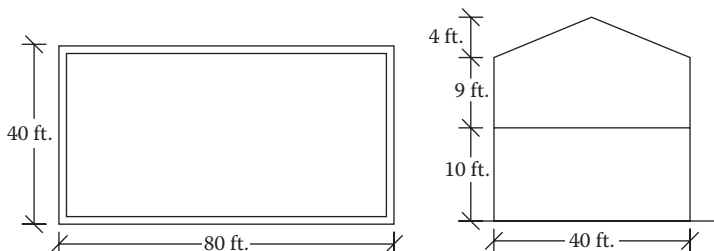
\* Use the tributary area not the effective area.

## PROBLEMS

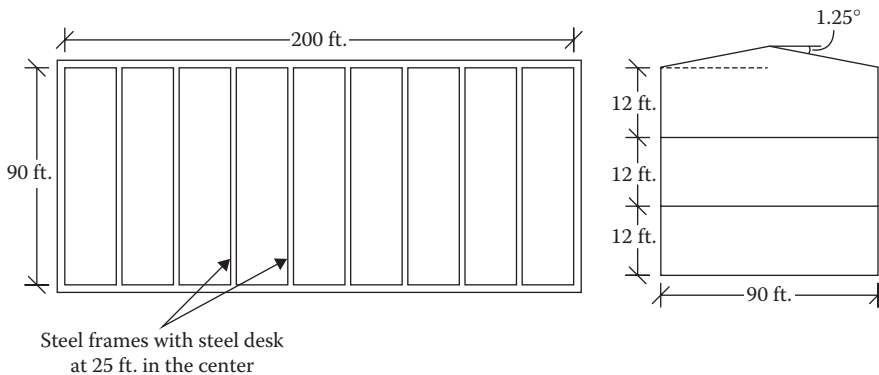
- 4.1** A circular-shaped office building is located in downtown Boston, Massachusetts. It has a height of 160 ft. to which the lateral load is transferred to the MWFRS through the floor and roof system. The front facing wall that receives the positive external pressure has an area of 1600 ft.<sup>2</sup> of which 400 ft.<sup>2</sup> is an open area. The other three side walls have a wall area of 1600 ft.<sup>2</sup> and openings of 100 ft.<sup>2</sup> each. Whether it is an open, partial open, or enclosed building? Which is the most appropriate MWFRS procedure to determine the wind loads?
- 4.2** A square 100-ft.-high office building transfers loads through floors and roof systems to the walls and foundations. All wall sizes are 1000 ft.<sup>2</sup> and there are openings of 200 ft.<sup>2</sup> each. Whether it is a partial open or enclosed building? What is the most appropriate procedure to determine the wind loads?
- 4.3** Consider a 100 ft. × 50 ft. five-story building where the first three stories are 9 ft. each and the other two stories are 8 ft. each. It is located in a remote open countryside in Maine, New England. The roof slope is 8°. Determine the exposure category and the height adjustment factor.
- 4.4** Consider a four-story coastal building in Newport, Rhode Island, where the height of each floor is 12.5 ft. The width of the building is 50 ft. and the roof slope is 14°. Determine the exposure category and the adjustment factor for height.
- 4.5** Determine the horizontal wind pressures and forces on the wall and the vertical pressures and forces acting on the roof due to wind acting in the transverse direction on an MWFRS as shown in Figure P4.1. It is a standard occupancy single-story building located in an urban area in Rhode Island where the basic wind speed is 140 mph.  $K_{zt} = 1$ .
- 4.6** In Problem 4.5, determine the horizontal pressures and forces and the vertical pressures and forces in the longitudinal direction.
- 4.7** An enclosed two-story heavily occupied building located in an open, flat terrain in Portland, Oregon, is shown in Figure P4.2. Determine the wind pressures on the walls and roofs of the MWFRS in the transverse direction. Also determine the design wind forces in the transverse direction.  $K_{zt} = 1$ .



**FIGURE P4.1** A single-story building in an urban area for Problem 4.5.



**FIGURE P4.2** A two-story building in open terrain for Problem 4.7.



**FIGURE P4.3** A three-story industrial building for Problem 4.9.

- 4.8** In Problem 4.7, determine the wind pressures and forces on the walls and roof in the longitudinal direction.
- 4.9** A three-story industrial steel building, shown in Figure P4.3, located in unobstructed terrain in Honolulu, Hawaii, has a plan dimension of 200 ft.  $\times$  90 ft. The structure consists of nine moment-resisting steel frames spanning 90 ft. at 25 ft. in the center. It is roofed with steel deck, which is pitched at  $1.25^\circ$  on each side from the center. The building is 36 ft. high with each floor having a height of 12 ft. Determine the MWFRS horizontal and vertical pressures and the forces due to wind in the transverse direction of the building.  $K_{zt} = 1$ .
- 4.10** In Problem 4.9, determine the MWFRS horizontal and vertical pressures and the forces in the longitudinal direction.
- 4.11** The building in Problem 4.5 has the wall studs and roof trusses spaced at 12 in. in the center. Determine the elemental wind pressures and forces on the studs and roof trusses.
- 4.12** The building in Problem 4.7 has the wall studs and roof trusses spaced at 16 in. in the center. Determine the elemental wind pressures and forces on the studs and roof trusses.
- 4.13** Determine the wind pressures and forces on the wall panel and roof decking from Problem 4.9. Decking is supported on joists that are 5 ft. in the center, spanning across the steel frames shown in Figure P4.3.



---

# 5 Earthquake Loads

## SEISMIC FORCES

The earth's outer crust is composed of very big, hard plates as large or larger than a continent. These plates float on the molten rock beneath. When these plates encounter each other, appreciable horizontal and vertical ground motion of the surface occurs known as the *earthquake*. For example, in the western portion of the United States, an earthquake is caused by the two plates comprising the North American continent and the Pacific basin. The ground motion induces a very large inertia force known as the *seismic force* in a structure that often results in the destruction of the structure. The seismic force acts vertically like dead and live loads and laterally like wind load. But unlike the other forces that are proportional to the exposed area of the structure, the seismic force is proportional to the mass of the structure and is distributed in proportion to the structural mass at various levels.

In all other types of loads including the wind load, the structural response is static wherein the structure is subjected to a pressure applied by the load. However, in a seismic load, there is no such direct applied pressure.

If ground movement could take place slowly, the structure would ride it over smoothly, moving along with it. But the quick movement of ground in an earthquake accelerates the mass of the structure. The product of the mass and acceleration is the internal force created within the structure. Thus, the seismic force is a dynamic entity.

## SEISMIC DESIGN PROCEDURES

Seismic analyses have been dealt with in detail in ASCE 7-10 in 13 chapters from Chapters 11 through 23. There are three approaches to evaluating seismic forces as follows:

1. Modal response spectrum analysis
2. Seismic response history procedure
3. Equivalent lateral force analysis

While the first two procedures are permitted to be applied to any type of structure, the third approach is applicable to structures that have no or limited structural irregularities.

In modal response spectrum analysis, an analysis is conducted to determine the natural modes of vibrations of the structure. For each mode, the force-related parameters are determined. The values of these design parameters for various modes are then combined by one of the three methods to determine the modal base shear.

The seismic response history procedure uses either a linear mathematical model of the structure or a model that accounts for the nonlinear hysteretic behavior of the structural elements. The model is analyzed to determine its response to the ground motion acceleration history compatible with the design response spectrum of the site.

In equivalent lateral force analysis, the seismic forces are represented by a set of supposedly equivalent static loads on a structure. It should be understood that no such simplified forces are fully equivalent to the complicated seismic forces but it is considered that a reasonable design of a structure can be produced by this approach. This approach has been covered in the book.

## DEFINITIONS

### 1. STRUCTURAL HEIGHT

Structural height,  $h_n$ , is the vertical distance from the base to the highest level of the seismic force-resisting system of the structure. For sloped roofs, it is from the base to the average height of the roof.\*

### 2. STORIES ABOVE BASE AND GRADE PLANE

Some seismic provisions in ASCE 7-10 refer to the number of stories (floors) *above the grade plane* whereas some other provisions are based on the number of stories *above the base or including the basement*.

A *grade plane* is a horizontal reference datum that represents the average of the finished ground level adjoining the structure at all exterior walls. If the finished ground surface is 6 ft. above the base of the building on one side and is 4 ft. above the base on the other side, the grade plane is 5 ft. above the base line.

Where the ground level slopes away from the exterior walls, the plane is established by the lowest points between the structure and the property line or where the property line is more than 6 ft. from the structure, between the structure and points 6 ft. from the structure.

A *story above the grade plane* is a story in which the floor surface or roof surface at the top of the story and is more than 6 ft. above the grade plane or is more than 12 ft. above the lowest finished ground level at any point on the perimeter of the structure, as shown in Figure 5.1.

Thus, a building with four stories above the grade plane and a basement below the grade plane is a five-story building above the base.

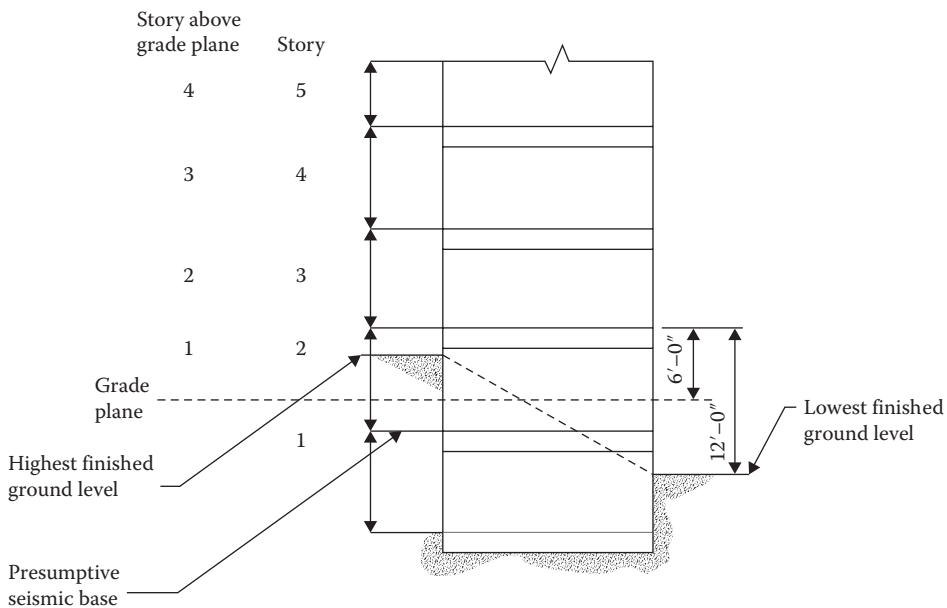


FIGURE 5.1 Story above grade plane and story above base.

\* For wind loads, mean roof height,  $h$ , is measured from the ground surface.

### 3. FUNDAMENTAL PERIOD OF STRUCTURE

The basic dynamic property of a structure is its fundamental period of vibration. When a mass of body (in this case a structure) is given a horizontal displacement (in this case due to earthquake), the mass oscillates back and forth. This is termed the *free vibration*. The *fundamental period* is defined as the time (in seconds) it takes to go through one cycle of free vibration. The magnitude depends on the mass of the structure and its stiffness. It can be determined by theory. ASCE 7-10 provides the following formula to approximate the fundamental time  $T_a$ :

$$T_a = C_t h_n^x \quad (5.1)$$

where

$T_a$  is approximate fundamental period in seconds

$h_n$  is height of the highest level of the structure above the base in ft.

$C_t$  is building period coefficient as given in Table 5.1

$x$  is exponential coefficient as given in Table 5.1

#### Example 5.1

Determine the approximate fundamental period for a five-story office building above the base, of moment-resisting steel, each floor having a height of 12 ft.

#### SOLUTION

1. Height of building from ground =  $5 \times 12 = 60$  ft.
2.  $T_a = 0.028(60)^{0.8} = 0.74$  seconds

### GROUND MOTION RESPONSE ACCELERATIONS

There are two terms applied to consider the most severe earthquake effects:

1. Maximum Considered Earthquake Geometric Mean ( $MCE_G$ )  
Peak Ground Acceleration

The earthquake effects by this standard are determined for geometric mean peak ground acceleration without adjustment for targeted risk.  $MCE_G$ , adjusted for site class effects, is used for soil-related issues—liquefaction, lateral spreading, and settlement.

2. Risk-Targeted Maximum Considered Earthquake ( $MCE_R$ )

Ground Motion Response Acceleration

Earthquake effects by this standard are determined for the orientation that results in the largest maximum response to horizontal ground motions with adjustment for targeted risk.  $MCE_R$ , adjusted for site class effects, is used to evaluate seismic-induced forces.

**TABLE 5.1**  
**Value of Parameters  $C_t$  and  $x$**

Structure Type	$C_t$	$x$
Moment-resisting frame of steel	0.028	0.8
Moment-resisting frame of concrete	0.016	0.9
Braced steel frame	0.03	0.75
All other structures	0.02	0.75

### MAPPED $MCE_R$ SPECTRAL RESPONSE ACCELERATION PARAMETERS

At the onset, the risk-adjusted maximum considered earthquake ( $MCE_R$ )\* ground motion parameters for a place are read from the spectral maps of the United States. There are two types of mapped accelerations: (1) short-period (0.2 seconds) spectral acceleration,  $S_s$ , which is used to study the acceleration-controlled portion of the spectra and (2) 1-second spectral acceleration,  $S_1$ , which is used to study the velocity-controlled portion of the spectra. These acceleration parameters represent 5% damped ground motions at 2% probability of exceedance in 50 years. The maps for the conterminous United States, reproduced from Chapter 22 of ASCE 7-10, are given in Figures 5.2 and 5.3. These maps and the maps for Alaska, Hawaii, Puerto Rico, and Virgin Islands are also available at the USGS site at <http://earthquake.usgs.gov/designmaps>. The values given in Figures 5.2 and 5.3 are percentages of the gravitational constant,  $g$ , that is, 200 means 2.0  $g$ .

### ADJUSTMENTS TO SPECTRAL RESPONSE ACCELERATION PARAMETERS FOR SITE CLASS EFFECTS

The mapped values of Figures 5.2 and 5.3 are for site soil category B. The site soil classification is given in Table 5.2.

For a soil of classification other than soil type B, the spectral response accelerations are adjusted as follows:

$$S_{MS} = F_a S_s \quad (5.2)$$

$$S_{M1} = F_v S_1 \quad (5.3)$$

where

$S_{MS}$  and  $S_{M1}$  are adjusted short-period and 1 s spectral accelerations for soil categories of Table 5.2  
 $F_a$  and  $F_v$  are site coefficients for short and 1 s spectra.

The values of factors  $F_a$  and  $F_v$  reproduced from ASCE 7-10 are given in Tables 5.3 and 5.4.

The factors are 0.8 for soil class A, 1 for soil class B, and higher than 1 for soils C onward, up to 3.5 for soil type E. Site class D should be used when the soil properties are not known in a sufficient detail.

### DESIGN SPECTRAL ACCELERATION PARAMETERS

These are the primary variables to prepare the design spectrum. The design spectral accelerations are two-thirds of the adjusted acceleration as follows:

$$S_{DS} = \frac{2}{3} S_{MS} \quad (5.4)$$

$$S_{D1} = \frac{2}{3} S_{M1} \quad (5.5)$$

where  $S_{DS}$  and  $S_{D1}$  are short-period and 1 s design spectral accelerations.

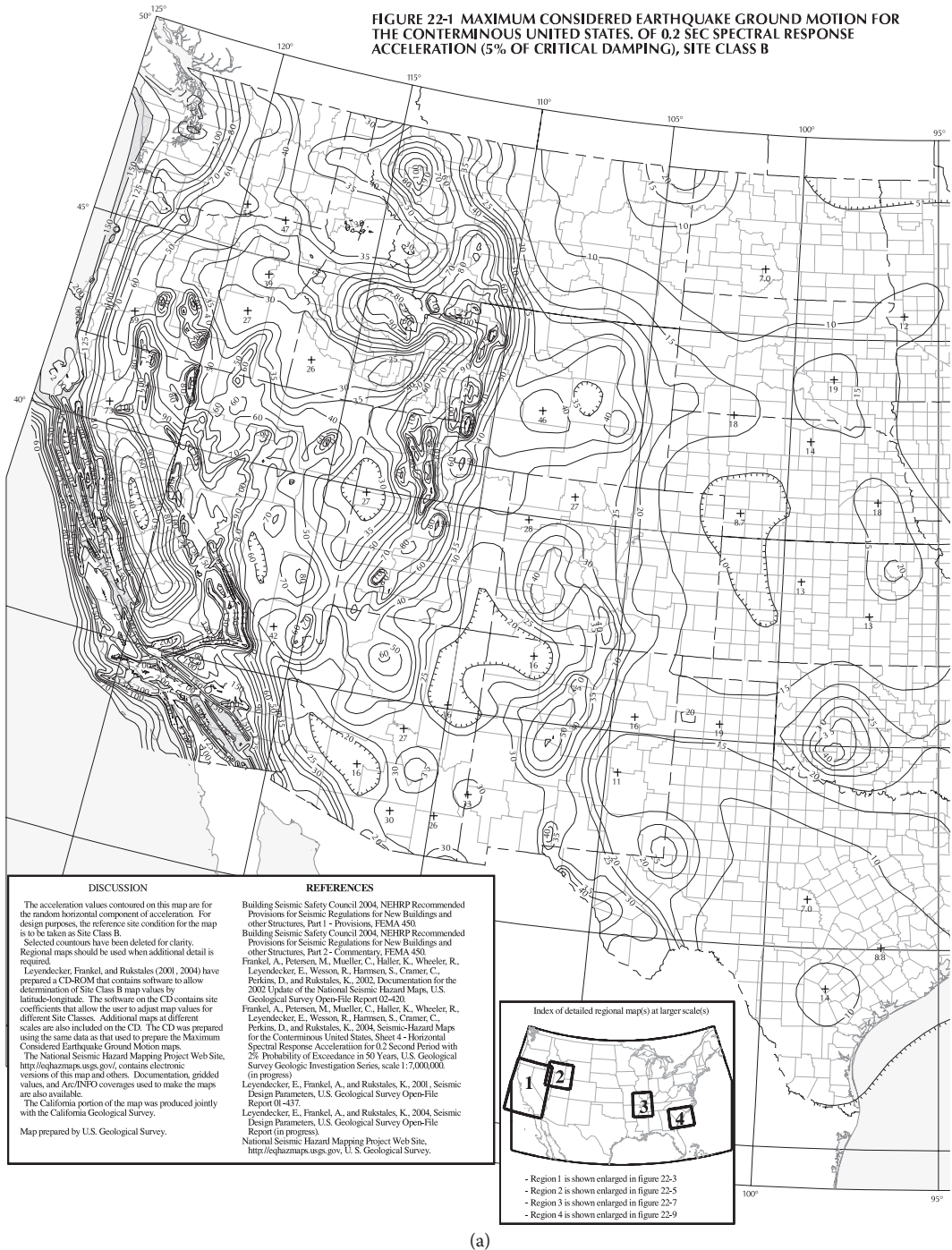
### DESIGN RESPONSE SPECTRUM

This is a graph that shows the design value of the spectral acceleration for a structure based on the fundamental period. A generic graph is shown in Figure 5.4 from which a site-specific graph is created based on the mapped values of accelerations and the site soil type.

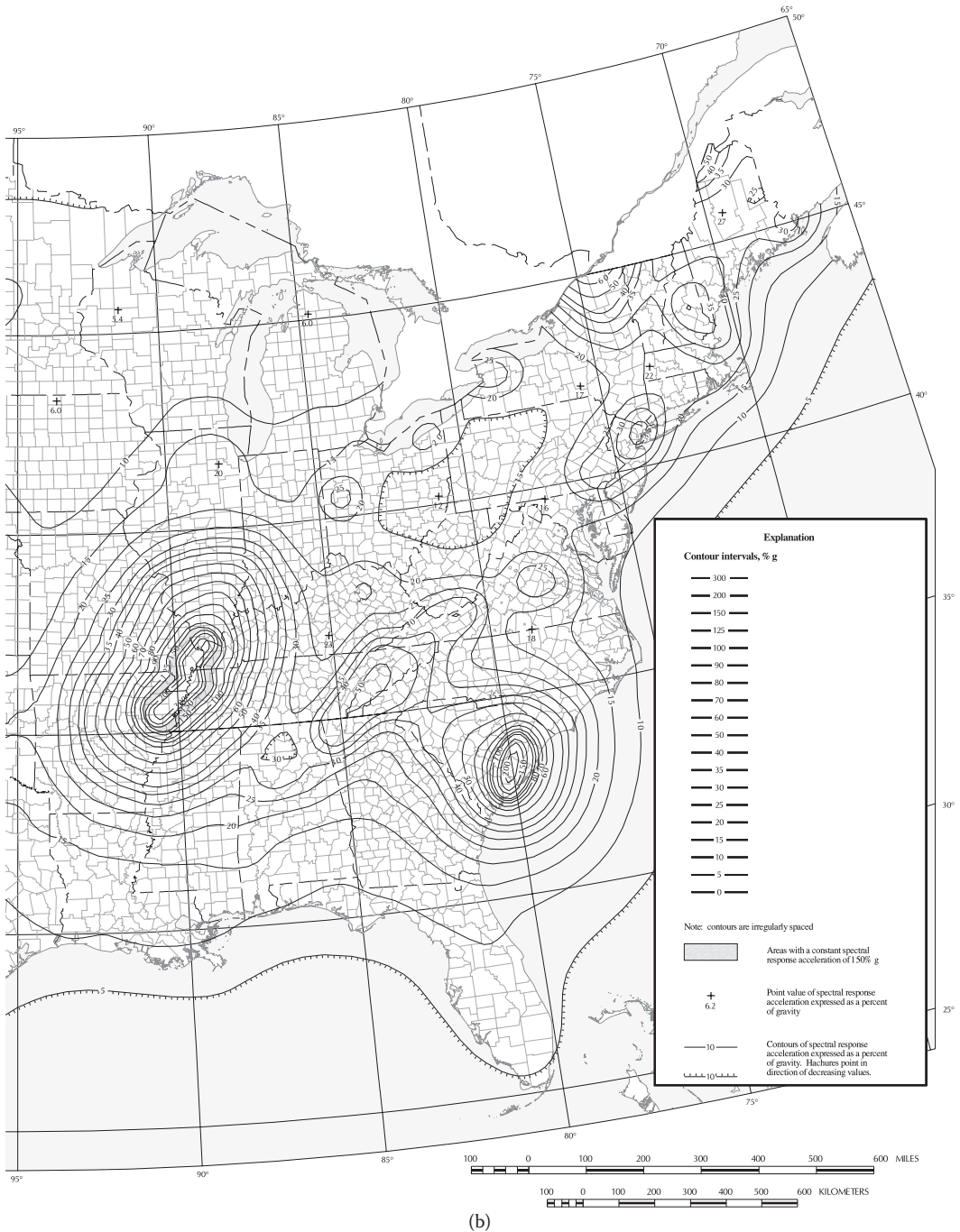
---

\* For practical purposes, it represents the maximum earthquake that can reasonably occur at the site.

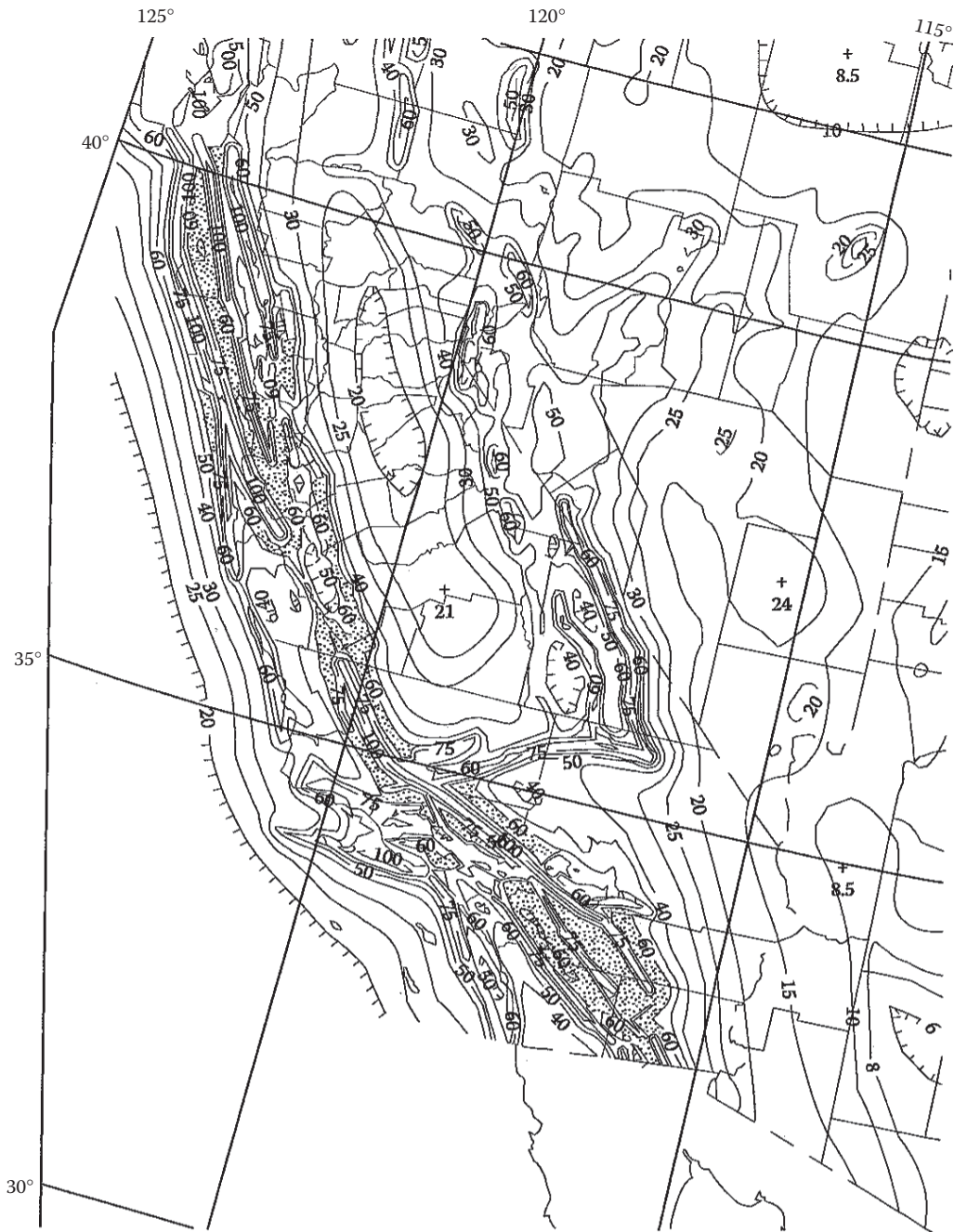




**FIGURE 5.2**  $S_w$ , risk-adjusted maximum considered earthquake ( $MCE_R$ ) ground motion parameter for the conterminous United States for 0.2-second spectral response acceleration (5% of critical damping), site class B. (a) and (b) are dividing of the country into two halves; (c) is enlarged portion of (a) and (b), respectively.

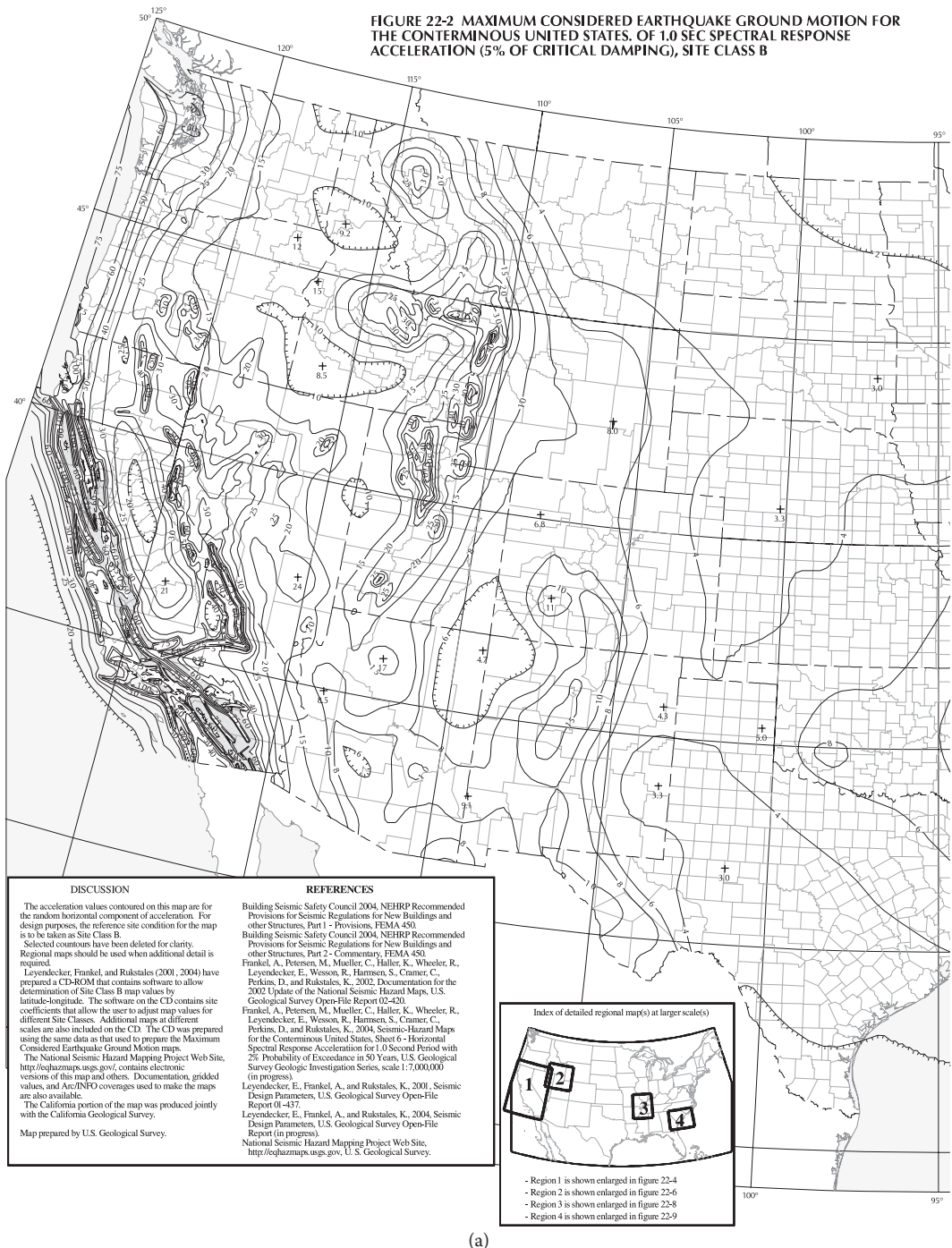


**FIGURE 5.2 (Continued)**  $S_s$ , risk-adjusted maximum considered earthquake ( $MCE_R$ ) ground motion parameter for the conterminous United States for 0.2-second spectral response acceleration (5% of critical damping), site class B.

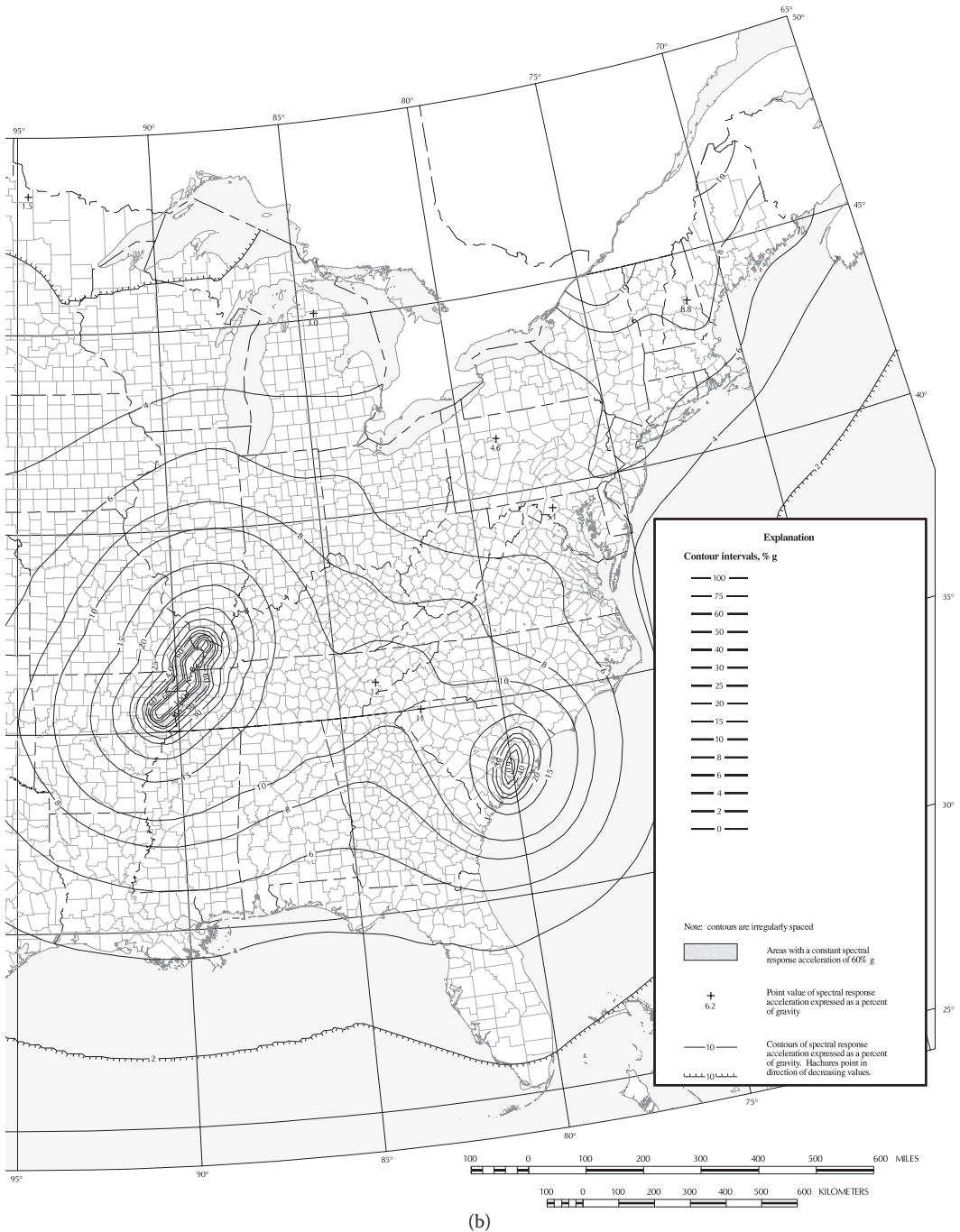


(c)

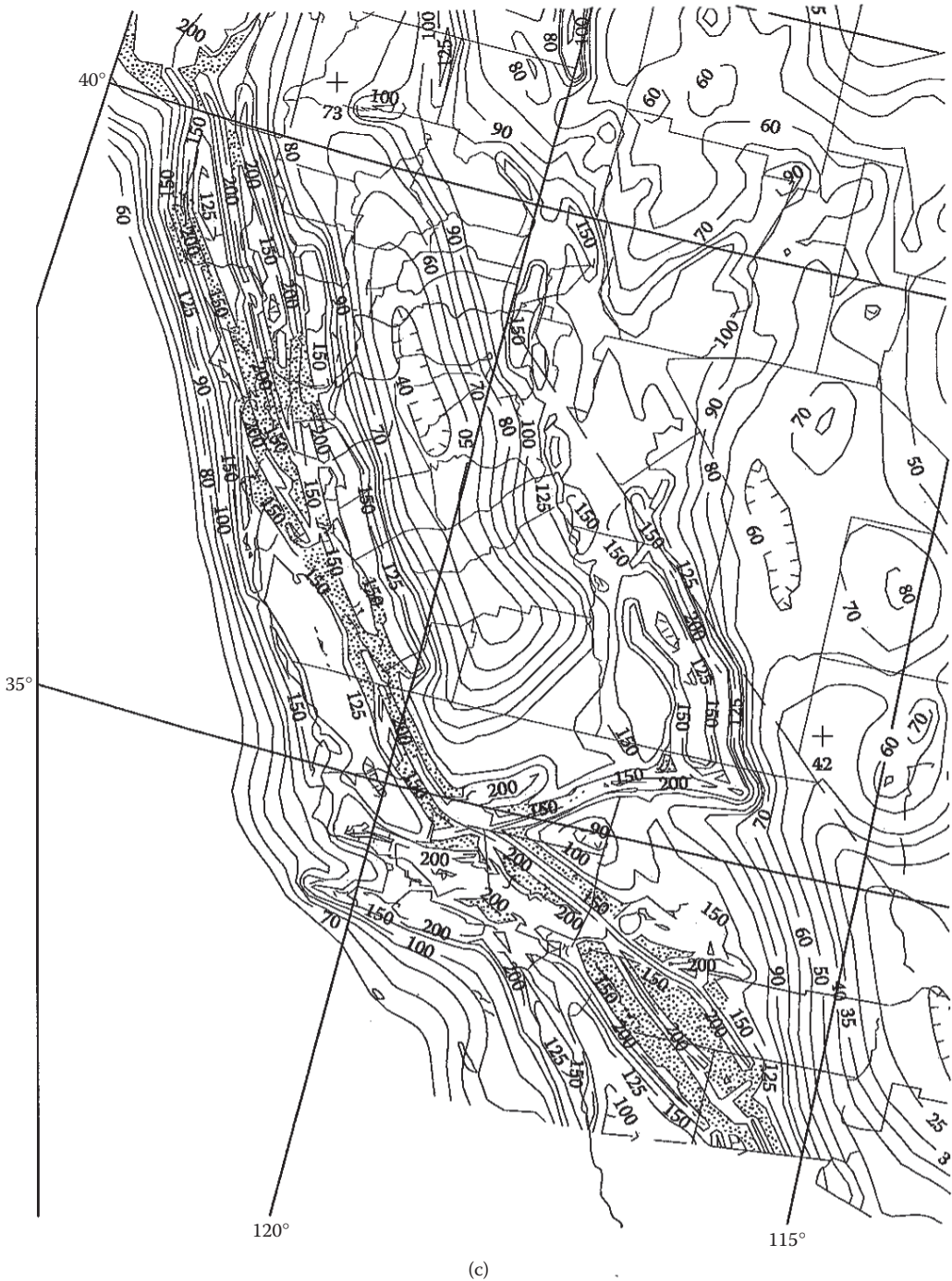
**FIGURE 5.2 (CONTINUED)**  $S_a$ , risk-adjusted maximum considered earthquake ( $MCE_R$ ) ground motion parameter for the conterminous United States for 0.2-second spectral response acceleration (5% of critical damping), site class B.



**FIGURE 5.3**  $S_1$ , risk-adjusted maximum considered earthquake ( $MCE_R$ ) ground motion parameter for the conterminous United States for 1-second spectral response acceleration (5% of critical damping), site class B. (a) and (b) are dividing of the country into two halves; (c) is enlarged portion of (a) and (b), respectively.



**FIGURE 5.3 (Continued)**  $S_1$ , risk-adjusted maximum considered earthquake ( $MCE_R$ ) ground motion parameter for the conterminous United States for 1-second spectral response acceleration (5% of critical damping), site class B.



**FIGURE 5.3 (Continued)**  $S_1$ , risk-adjusted maximum considered earthquake ( $MCE_R$ ) ground motion parameter for the conterminous United States for 1-second spectral response acceleration (5% of critical damping), site class B.

**TABLE 5.2**  
**Soil Classification for Spectral Acceleration**

Class	Type
A	Hard rock
B	Rock
C	Soft rock or very dense soil
D	Stiff soil
E	Soft soil
F	Requires site-specific evaluation

**TABLE 5.3**  
**Site Coefficient,  $F_a$**

Site Class	MCE <sub>R</sub> at Short Period				
	$S_s \leq 0.25$	$S_s = 0.5$	$S_s = 0.75$	$S_s = 1.0$	$S_s \geq 1.25$
A	0.8	0.8	0.8	0.8	0.8
B	1.0	1.0	1.0	1.0	1.0
C	1.2	1.2	1.1	1.0	1.0
D	1.6	1.4	1.2	1.1	1.0
E	2.5	1.7	1.2	0.9	0.9
F	See Section 11.4.7 of ASCE 7-10				

Note: Use straight-line interpolation for intermediate values of  $S_s$ .

**TABLE 5.4**  
**Site Coefficient,  $F_v$**

Site Class	MCE <sub>R</sub> at 1-Second Period				
	$S_1 \leq 0.1$	$S_1 = 0.2$	$S_1 = 0.3$	$S_1 = 0.4$	$S_1 \geq 0.5$
A	0.8	0.8	0.8	0.8	0.8
B	1.0	1.0	1.0	1.0	1.0
C	1.7	1.6	1.5	1.4	1.3
D	2.4	2.0	1.8	1.6	1.5
E	3.5	3.2	2.8	2.4	2.4
F	See Section 11.4.7 of ASCE 7-10				

Note: Use straight-line interpolation for intermediate values of  $S_1$ .

The controlling time steps at which the shape of the design response spectrum graph changes are as follows:

1. Initial period

$$T_0 = 0.2 \frac{S_{D1}}{S_{DS}} \tag{5.6}$$

2. Short-period transition for small structure

$$T_s = \frac{S_{D1}}{S_{DS}} \tag{5.7}$$

3. Long-period transition for large structures

$T_L$  is shown in Figure 5.5, which is reproduced from ASCE 7-10.

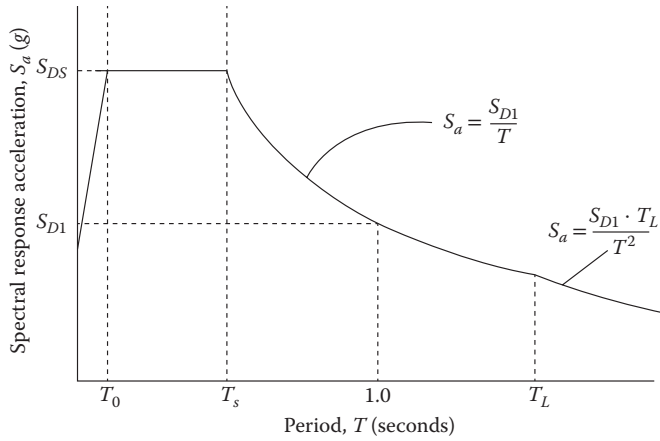
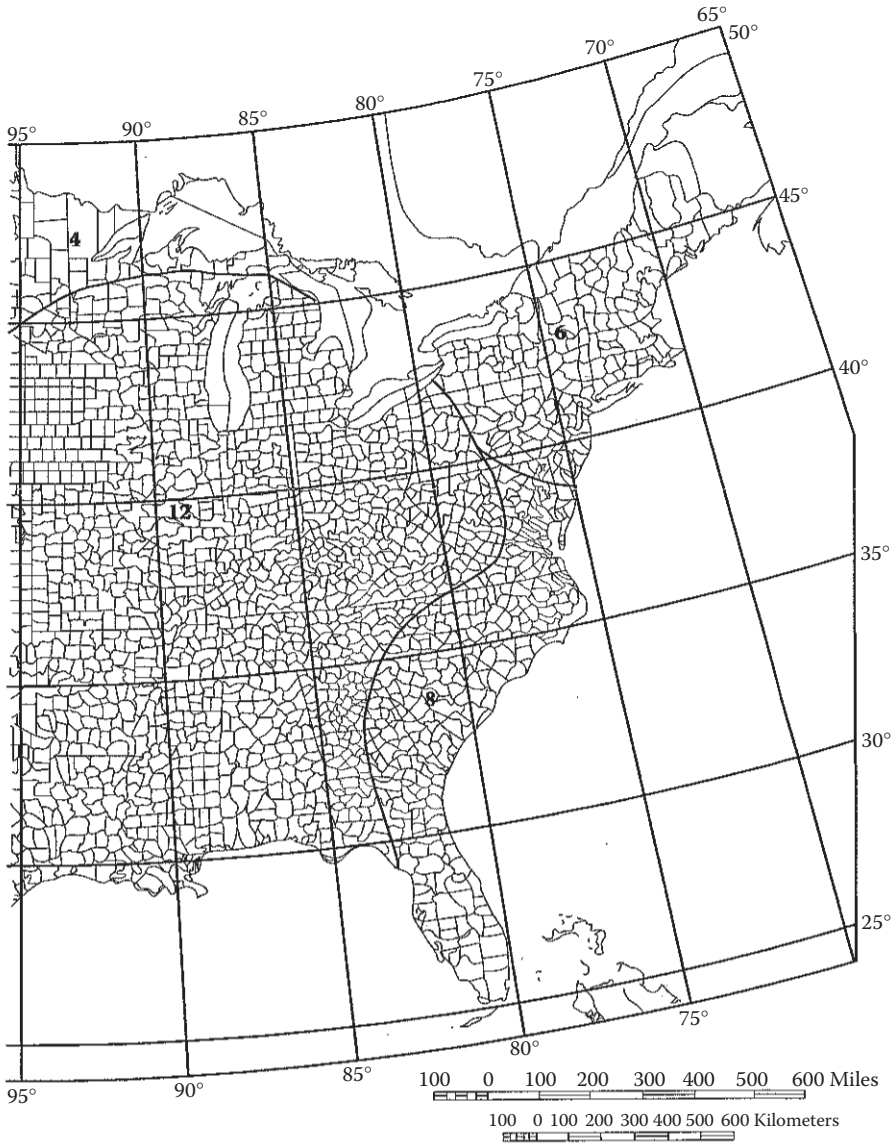


FIGURE 5.4 Design response spectrum. (Courtesy of American Society of Civil Engineers, Reston, VA.)



FIGURE 5.5 Long-period transition period,  $T_L$ . (a) and (b) divide the country in two halves. (Courtesy of American Society of Civil Engineers, Reston, VA.)





(b)

**FIGURE 5.5 (Continued)** Long-period transition period,  $T_L$ . (Courtesy of American Society of Civil Engineers, Reston, VA.)

The characteristics of the design response spectrum are as follows:

1. For the fundamental period,  $T_a$ , having a value between 0 and  $T_0$ , the design spectral acceleration,  $S_a$ , varies as a straight line from a value of  $0.4S_{DS}$  and  $S_{DS}$ , as shown in Figure 5.4.
2. For the fundamental period,  $T_a$ , having a value between  $T_0$  and  $T_s$ , the design spectral acceleration,  $S_a$ , is constant at  $S_{DS}$ .
3. For the fundamental period,  $T_a$ , having a value between  $T_s$  and  $T_L$ , the design spectral acceleration,  $S_a$ , is given by

$$S_a = \frac{S_{D1}}{T} \tag{5.8}$$

where  $T$  is time period between  $T_s$  and  $T_L$ .

4. For the fundamental period,  $T_a$ , having a value larger than  $T_L$ , the design spectral acceleration is given by

$$S_a = \frac{S_{D1}T_L}{T^2} \quad (5.9)$$

The complete design response spectrum\* graph is shown in Figure 5.4.

### Example 5.2

At a location in California, the mapped values of the  $MCE_R$  accelerations  $S_s$  and  $S_1$  are 1.5 g and 0.75 g, respectively. The site soil class is D. Prepare the design spectral response curve for this location.

### SOLUTION

1. Adjustment factors for soil class D are as follows:

$$F_a = 1.0$$

$$F_v = 1.5$$

2.  $S_{MS} = F_a S_s$

$$= (1.0)(1.5 \text{ g}) = 1.5 \text{ g}$$

$$S_{M1} = F_v S_1$$

$$= (1.5)(0.75 \text{ g}) = 1.13 \text{ g}$$

3.  $S_{DS} = \frac{2}{3} S_{MS} = \frac{2}{3}(1.5 \text{ g}) = 1 \text{ g}$

$$S_{D1} = \frac{2}{3} S_{M1} = \frac{2}{3}(1.13 \text{ g}) = 0.75 \text{ g}$$

4.  $T_o = \frac{0.2S_{D1}}{S_{DS}} = \frac{0.2(0.75 \text{ g})}{1 \text{ g}} = 0.15 \text{ seconds}$

$$T_s = \frac{0.75 \text{ g}}{1 \text{ g}} = 0.75 \text{ seconds}$$

$$T_L = 8 \text{ seconds (from Figure 5.5)}$$

5. The design spectral acceleration at time 0 is 0.4 (1 g) or 0.4 g. It linearly rises to 1 g at time 0.15 seconds. It remains constant at 1 g up to time 0.75 seconds. From time 0.75 to 8 seconds, it drops at a rate 0.75 g/T. At 0.75 seconds, it is 0.75 g/0.75 = 1 g and progresses to a value of 0.75 g/8 = 0.094 g at time 8 seconds. Thereafter, the rate of drop is  $S_{D1}T_L/T^2$  or 6 g/T<sup>2</sup>. This is shown in Figure 5.6.

### IMPORTANCE FACTOR, $I$

The importance factor,  $I$ , for a seismic coefficient, which is based on the risk category of the structure, is indicated in Table 5.5. The risk category is discussed in the “Classification of Buildings” section in Chapter 1.

### SEISMIC DESIGN CATEGORIES

A structure is assigned a seismic design category (SDC) from A through F based on the risk category of the structure and the design spectral response acceleration parameters,  $S_{DS}$  and  $S_{D1}$ , of the

\* Where an  $MCE_R$  response spectrum is required, multiply the design response spectrum,  $S_a$ , by 1.5.

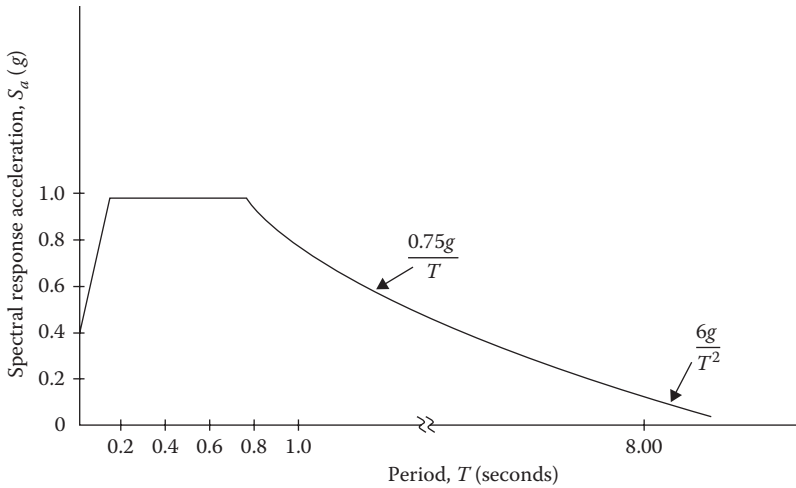


FIGURE 5.6 Design spectral acceleration, Example 5.2.

**TABLE 5.5**  
**Importance Factor for Seismic Coefficient**

Risk Category	Importance Factor
I and II	1.0
III	1.25
IV	1.5

**TABLE 5.6**  
**SDC Based on  $S_{DS}$**

$S_{DS}$ Range	Risk Category		
	I or II (low risk and standard occupancy)	III (high occupancy)	IV (essential occupancy)
0 to < 0.167 g	A	A	A
0.167 g to < 0.33 g	B	B	C
0.33 g to $\leq$ 0.5 g	C	C	D
>0.5 g	D	D	D
When $S_1 \geq 0.75$ g	E	E	F

site. The seismic design categories are given in Tables 5.6 and 5.7. A structure is assigned to the severest category determined from the two tables except for the following cases:

1. When  $S_1$  is 0.75 g or more, a structure is assigned category E for I, II, and III risk categories and assigned category F for risk category IV.
2. When  $S_1$  is less than 0.75 g and certain conditions of the small structure are met, as specified in 11.6 of ASCE 7-10, only Table 5.6 is applied.

**TABLE 5.7**  
**SDC Based on  $S_{D1}$**

Range $S_{D1}$	I or II (Low Risk and Standard Occupancy)	III (High Occupancy)	IV (Essential Occupancy)
0 to < 0.067 g	A	A	A
0.067 g to < 0.133 g	B	B	C
0.133 g to $\leq$ 0.20 g	C	C	D
>0.2 g	D	D	D
When $S_1 \geq 0.75$ g	E	E	F

## EXEMPTIONS FROM SEISMIC DESIGNS

ASCE 7-10 exempts the following structures from the seismic design requirements:

1. The structures belonging to SDC A; these need to comply only to the requirements of the “Continuous Load Path for Structural Integrity” section of Chapter 1.
2. The detached one- and two-family dwellings in SDC A, SDC B, and SDC C or where  $S_s < 0.4$ .
3. The conventional wood frame one- and two-family dwellings up to two stories in any seismic design category.
4. The agriculture storage structures used only for incidental human occupancy.

## EQUIVALENT LATERAL FORCE PROCEDURE TO DETERMINE SEISMIC FORCE

The design base shear,  $V$ , due to seismic force is expressed as

$$V = C_s W \quad (5.10)$$

where

$W$  is effective dead weight of structure, discussed in the “Effective Weight of Structure,  $W$ ” section  
 $C_s$  is seismic response coefficient, discussed in the “Seismic Response Coefficient,  $C_s$ ” section

### EFFECTIVE WEIGHT OF STRUCTURE, $W$

Generally, this is taken as the dead load of the structure. However, where a structure carries a large live load, a portion is included in  $W$ . For a storage warehouse, 25% of floor live load is included with the dead load in  $W$ . Where the location of partitions (nonbearing walls) are subject to relocation, a floor live load of 10 psf is added in  $W$ . When the flat roof snow load exceeds 30 psf, 20% of the snow load is included in  $W$ .

### SEISMIC RESPONSE COEFFICIENT, $C_s$

The value of  $C_s$  for different time periods of the design spectrum is shown in Figure 5.7. Besides depending on the fundamental period and design spectral accelerations,  $C_s$  is a function of the importance factor and the response modification factor. The importance factor,  $I$ , is given in Table 5.5. The response modification factor,  $R$ , is discussed in the “Response Modification Factor or Coefficient,  $R$ ” section.

### Maximum $S_s$ Value in Determining $C_s$

For the regular structures five stories or less above the base and when the period  $T$  is  $\leq 0.5_s$ ,  $C_s$  is calculated using a value of  $S_s = 1.5$  while computing  $S_{DS}$  or  $S_{D1}$  in equation for  $C_s$ .

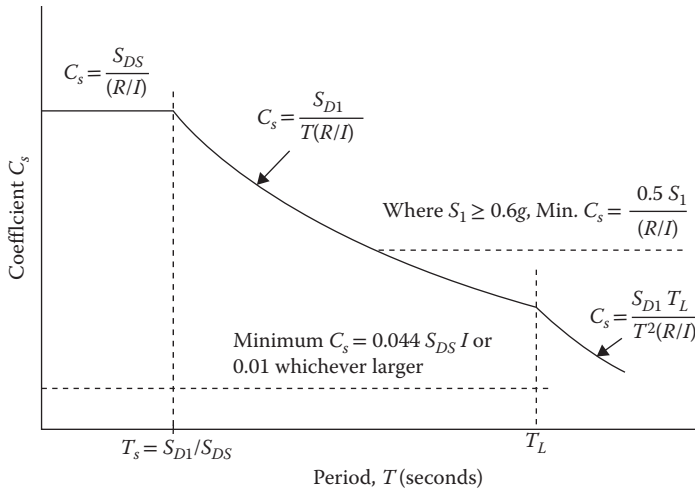


FIGURE 5.7 Seismic response coefficient for base shear.

**RESPONSE MODIFICATION FACTOR OR COEFFICIENT,  $R$**

The response modification factor accounts for the following:

1. Ductility, which is the capacity to withstand stresses in the inelastic range
2. Overstrength, which is the difference between the design load and the failure load
3. Damping, which is the resistance to vibration by the structure
4. Redundancy, which is an indicator that a component’s failure does not lead to failure of the entire system

A large value of the response modification factor reduces the seismic response coefficient and hence the design shear. The factor ranges from 1 to 8. Ductile structures have a higher value and brittle ones have a lower value. Braced steel frames with moment-resisting connections have the highest value and concrete and masonry shear walls have the smallest value. For wood-frame construction, the common  $R$ -factor is 6.5 for wood and light metal shear walls and 5 for special reinforced concrete shear walls. An exhaustive list is provided in Table 12.2-1 of ASCE 7-10.

**Example 5.3**

The five-story moment-resisting steel building of Example 5.1 is located in California, where  $S_s$  and  $S_1$  are 1.5  $g$  and 0.75  $g$ , respectively. The soil class is D. Determine (1) the SDC and (2) the seismic response coefficient,  $C_s$ .

**SOLUTION**

1. From Example 5.1  
 $T_s = 0.74$  seconds
2. From Example 5.2  
 $S_{DS} = 1 g$  and  $S_{D1} = 0.75 g$   
 $T_0 = 0.15$  seconds and  $T_s = 0.75$  seconds

3. To compute the SDC
  - a. Risk category II
  - b. From Table 5.6, for  $S_1 \geq 0.75$  g and category II, SDC is E
4. To compute the seismic coefficient
  - a. Importance factor from Table 5.5,  $I = 1$
  - b. Response modification factor,  $R = 8$
  - c.  $T_a$  (of 0.74 seconds)  $<$   $T_s$  (of 0.75 seconds)
  - d. From Figure 5.7, for  $T_a < T_s$ ,  $C_s = S_{DS}/(R/I)$

$$C_s = \frac{1g}{\left(\frac{8}{1}\right)} = 0.125g$$

**DISTRIBUTION OF SEISMIC FORCES**

The seismic forces are distributed throughout the structure in reverse order. The shear force at the base of the structure is computed from the base shear, Equation 5.10. Then story forces are assigned at the roof and floor levels by distributing the base shear force over the height of the structure.

The primary lateral force–resisting system consists of horizontal and vertical elements. In conventional buildings, the horizontal elements consist of roof and floors acting as horizontal diaphragms. The vertical elements consist of studs and end shear walls.

The seismic force distribution for vertical elements (e.g., walls), designated by  $F_x$ , is different from the force distribution for horizontal elements designed by  $F_{px}$  that are applied to design the horizontal components. It should be understood that both  $F_x$  and  $F_{px}$  are horizontal forces that are differently distributed at each story level. The forces acting on horizontal elements at different levels are not additive, whereas all of the story forces on vertical elements are considered to be acting concurrently and are additive from top to bottom.

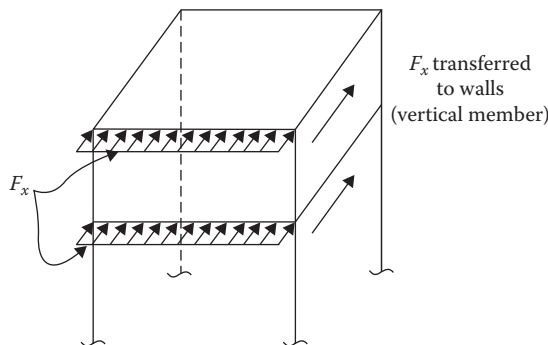
**DISTRIBUTION OF SEISMIC FORCES ON VERTICAL WALL ELEMENTS**

The distribution of horizontal seismic forces acting on the vertical element (wall) is shown in Figure 5.8. The lateral seismic force induced at any level is determined from the following equations:

$$F_x = C_{vx}V \tag{5.11}$$

and

$$C_{vx} = \frac{W_x h_x^k}{\sum W_i h_i^k} \tag{5.12}$$



**FIGURE 5.8** Distribution of horizontal seismic force to vertical elements.

Substituting Equation 5.12 in Equation 5.11, we obtain

$$F_x = \frac{(Vh_x^k)W_x}{\sum W_i h_i^k} \tag{5.13}$$

where

$i$  is index for floor level,  $i = 1$ , first level and so on

$F_x$  is horizontal seismic force on vertical elements at floor level  $x$

$C_{vx}$  is vertical distribution factor

$V$  is shear at the base of the structure from Equation 5.10

$W_i$  or  $W_x$  is effective seismic weight of the structure at index level  $i$  or floor level  $x$

$h_i$  or  $h_x$  is height from base to index level  $i$  or floor level  $x$

$k$  is an exponent related to the fundamental period of structure,  $T_a$ , as follows: (1) for  $T_a \leq 0.5s$ ,  $k = 1$  and (2) for  $T_a > 0.5s$ ,  $k = 2$

The total shear force,  $V_x$ , in any story is the sum of  $F_x$  from the top story up the  $x$  story. The shear force of an  $x$  story level,  $V_x$ , is distributed among the various vertical elements in that story on the basis of the relative stiffness of the elements.

### DISTRIBUTION OF SEISMIC FORCES ON HORIZONTAL ELEMENTS (DIAPHRAGMS)

The horizontal seismic forces transferred to the horizontal components (diaphragms) are shown in Figure 5.9. The floor and roof diaphragms are designed to resist the following minimum seismic force at each level:

$$F_{px} = \frac{\sum_{i=x}^n F_i W_{px}}{\sum_{i=x}^n W_i} \tag{5.14}$$

where

$F_{px}$  is diaphragm design force

$F_i$  is lateral force applied to level  $i$ , which is the summation of  $F_x$  from level  $x$  (being evaluated) to the top level

$W_{px}$  is effective weight of diaphragm at level  $x$ . The weight of walls parallel to the direction of  $F_{px}$  need not be included in  $W_{px}$

$W_i$  is effective weight at level  $i$ , which is the summation of weight from level  $x$  (being evaluated) to the top

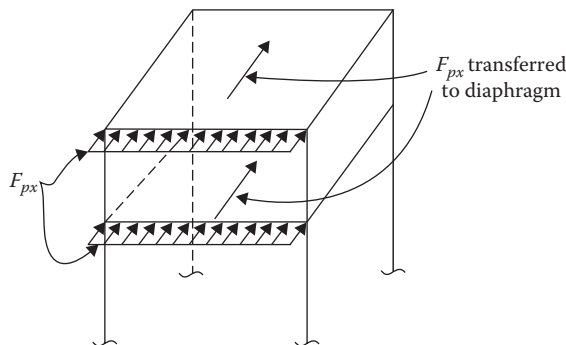


FIGURE 5.9 Distribution of horizontal seismic force to horizontal elements.

The force determined by Equation 5.14 is subject to the following two conditions:  
The force should not be more than

$$F_{px}(\text{max}) = 0.4S_{DS}IW_{px} \quad (5.15)$$

The force should not be less than

$$F_{px}(\text{min}) = 0.2S_{DS}IW_{px} \quad (5.16)$$

## DESIGN EARTHQUAKE LOAD

An earthquake causes horizontal accelerations as well as vertical accelerations. Accordingly, the earthquake load has two components. In load combinations, it appears in the following two forms:

$$E = E_{\text{horizontal}} + E_{\text{vertical}} \quad (\text{in Equation 1.25}) \quad (5.17)$$

and

$$E = E_{\text{horizontal}} - E_{\text{vertical}} \quad (\text{in Equation 1.27}) \quad (5.18)$$

when

$$E_{\text{horizontal}} = \rho Q_E \quad (5.19)$$

and

$$E_{\text{vertical}} = 0.2S_{DS}W \quad (5.20)$$

where

$Q_E$  is horizontal seismic forces  $F_x$  or  $F_{px}$  as determined in the “Distribution of Seismic Forces” section

$W$  is dead load  $W_x$  as determined in the “Distribution of Seismic Forces” section

$\rho$  is redundancy factor

The redundancy factor  $\rho$  is 1.00 for seismic design categories A, B, and C. It is 1.3 for SDC D, SDC E, and SDC F, except for special conditions. The redundancy factor is always 1.0 for  $F_{px}$  forces.

$E_{\text{horizontal}}$  is combined with horizontal forces and  $E_{\text{vertical}}$  with vertical forces.

The seismic forces are at the load resistance factor design (strength) level and have a load factor of 1. To be combined for the allowable stress design, these should be multiplied by a factor of 0.7.

### Example 5.4

A two-story wood-frame essential facility as shown in Figure 5.10 is located in Seattle, Washington. The structure is a bearing wall system with reinforced shear walls. The loads on the structures are as follows. Determine the earthquake loads acting on the vertical elements of the structure.

Roof dead load (DL) = 20 psf (in horizontal plane)

Floor dead load (DL) = 15 psf

Partition live load (PL) = 15 psf

Exterior wall dead load (DL) = 60 psf



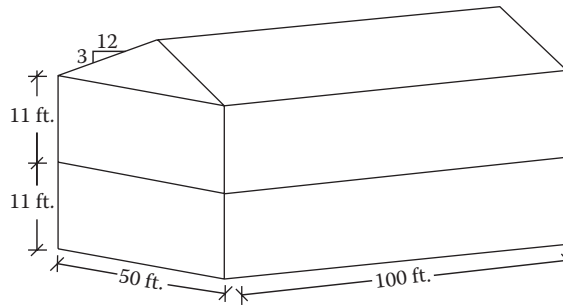


FIGURE 5.10 A two-story wood-frame structure.

**SOLUTION**

A. Design parameters

1. Risk category = Essential, IV
2. Importance factor from Table 5.5 for IV category = 1.5
3. Mapped  $MCE_R$  response accelerations  
 $S_s = 1 g$  and  $S_1 = 0.4 g$
4. Site soil class (default) = D
5. Seismic force-resisting system  
 Bearing wall with reinforced shear walls
6. Response modification coefficient = 5

B. Seismic response parameters

1. Fundamental period (from Equation 5.1)  $T_a = C_t h^x$ . From Table 5.1,  $C_t = 0.02$ ,  $x = 0.75$ .  
 $T_a = 0.02(25.125)^{0.75} = 0.224$  seconds
2. From Table 5.3,  $F_a = 1.1$   
 $S_{MS} = F_a S_s = 1.1(1) = 1.1 g$
3. From Table 5.4,  $F_v = 1.6$   
 $S_{M1} = F_v S_1 = 1.6(0.4g) = 0.64 g$
4.  $S_{DS} = \frac{2}{3} S_{MS} = \frac{2}{3}(1.1g) = 0.73 g$   
 $S_{D1} = \frac{2}{3} S_{M1} = \frac{2}{3}(0.64 g) = 0.43 g$
5. Based on risk category and  $S_{DS}$ , SDC = D.  
 Based on risk category and  $S_{D1}$ , SDC = D.
6.  $T_s = S_{D1}/S_{DS} = 0.43 g/0.73 g = 0.59$  seconds  
 Since  $T_a < T_{sr}$ ,  $C_s = S_{DS}/(R/I) = 0.73 g/(5/1.5) = 0.22 g^*$

C. Effective seismic weight at each level

1.  $W$  at roof level†
  - i. Area(roof DL) =  $(50 \times 100)(20)/1000 = 100$  k
  - ii. 2 Longitudinal walls =  $2(\text{wall area})(\text{wall DL})$   

$$= \frac{2(100 \times 11)(60)}{1000} = 132$$
 k
  - iii. 2 End walls =  $2(\text{wall area})(\text{DL})$   

$$= \frac{2(50 \times 11)(60)}{1000} = 66$$
 k

Total = 298 k

\* This is for the mass of the structure. For weight, the value is 0.22.

† It is also a practice to assign at the roof level one-half the second floor wall height.

**TABLE 5.8**  
**Seismic Force Distribution on Vertical Members**

Level, $x$	$W_x$ , k	$h_x$ , ft.	$W_x h_x$ , k <sup>a</sup>	$Vh_x$ or $136.6h_x$ , k ft. <sup>b</sup>	$F_x$ , k <sup>c</sup>	$V_x$ (Shear at Story), k <sup>d</sup>
(1)	(2)	(3)	(4)	(5)	(6)	(7)
Roof	298	22	6,556	3005.2	88.60	88.60
Second	323	11	3,553	1502.6	48.00	136.60
$\Sigma$	621		10,109			

<sup>a</sup> Column 2  $\times$  column 3.

<sup>b</sup>  $136.6 \times$  column 3.

<sup>c</sup> Column 2  $\times$  column 5/summation of column 4.

<sup>d</sup> Cumulate column 6.

**TABLE 5.9**  
**Earthquake Loads on Vertical Elements**

Level, $x$	$W_x$ , k	$F_x$ , k	$E_{\text{horizontal}} = \rho F_x$ , k	$E_{\text{vertical}} = 0.2S_{DS} W_x$ , k
Roof	298	88.6	115.2	43.5
Second	323	48.0	62.4	47.2

2.  $W$  at second floor\*
  - i. Area(floor DL + partition load<sup>†</sup>) =  $(50 \times 100)(15 + 10)/1000 = 125$  k
  - ii. 2 Longitudinal walls = 132 k
  - iii. 2 End walls = 66 k

Total = 323 k  
Total effective building weight  $W = 621$  k

D. Base shear

$$V = C_s W = 0.22(621) = 136.6 \text{ k}$$

E. Lateral seismic force distribution on the vertical shear walls

1. From Equation 5.13, since  $T_a < 0.5$  s,  $k = 1$

$$F_x = \frac{(Vh_x)W_x}{\sum W_i h_i}$$

2. The computations are arranged in Table 5.8.

F. Earthquake loads for the vertical members

1. The redundancy factor  $\rho$  for SDC D is 1.3.
2. The horizontal and vertical components of the earthquake loads for vertical members (walls) are given in Table 5.9.
3. The earthquake forces are shown in Figure 5.11.

\* It is also a practice to assign at the second floor level, the wall load from one-half of the second floor wall and one-half of the first floor wall. This leaves the weight of one-half of the first floor wall not included in the effective weight.

† ASCE 7-10 prescribes 15 psf for partition live load but it recommends that for seismic load computation the partition load should be taken as 10 psf.

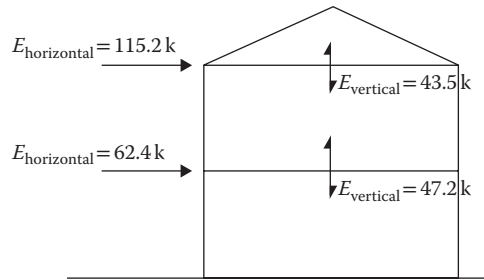


FIGURE 5.11 Earthquake loads on vertical elements, Example 5.4.

TABLE 5.10  
Seismic Force Distribution on Horizontal Members

Level, $x$	$W_x$ , k	$W_{px}$ , k <sup>a</sup>	$F_i$ from		$\Sigma W_i$ , k <sup>c</sup>	$F_{px}$ , k <sup>d</sup>	Max. <sup>e</sup>	Min.
			Table 5.8, k	$\Sigma F_{ir}$ , k <sup>b</sup>			$0.4S_{DS}/W_{px}$ , k	$0.2S_{DS}/W_{px}$ , k
(1)	(2)	(3)	(4)	(5)	(6)	(7)	(8)	(9)
Roof	298	232	88.60	88.60	298	69.00	101.62	50.8
Second	323	257	48.00	136.60	621	56.5 <sup>f</sup>	112.57	56.3

- <sup>a</sup>  $W_x$ —parallel exterior walls weight = 298 – 66 = 232 k.
- <sup>b</sup> Summation of column 4.
- <sup>c</sup> Summation of column 2.
- <sup>d</sup> Column 3 × column 5/column 6.
- <sup>e</sup>  $0.4S_{DS}/W_{px} = 0.4(0.73)(1.5)(232) = 101.62$  k.
- <sup>f</sup> Since 56.5 k is less than 112.57 k and more than 56.3 k, it is OK.

**Example 5.5**

For Example 5.4, determine the earthquake loads acting on the horizontal members (diaphragms).

**SOLUTION**

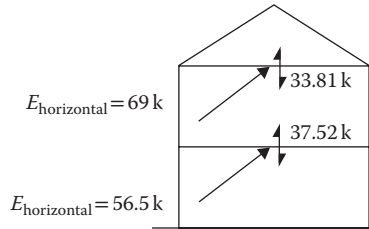
- A. Lateral seismic force distribution on the horizontal members
  - 1. From Equation 5.14

$$F_{px} = \frac{\left(\sum_{i=x}^n F_i\right) W_{px}}{\sum_{i=x}^n W_i}$$

- 2. The computations are arranged in Table 5.10.
- B. Earthquake loads for vertical members
  - 1. The redundancy factor  $\rho$  for  $F_{px}$  is always 1.0.
  - 2. The horizontal and vertical components of the earthquake loads for horizontal members (diaphragms) are given in Table 5.11.
  - 3. The earthquake forces on the horizontal members are shown in Figure 5.12.

**TABLE 5.11**  
**Earthquake Loads on Horizontal Elements**

Level, $x$	$W_{px}$ , k	$F_{px}$ , k	$E_{horizontal} = F_{px}$ , k	$E_{vertical} = 0.2S_{D5}W_{px}$ , k
Roof	232	69.0	69.0	33.81
Second	257	56.5	56.5	37.52



**FIGURE 5.12** Loads on horizontal elements, Example 5.4.

**SOIL–STRUCTURE INTERACTION**

The above combination of forces did not consider the interaction between the structure foundation and the soil, which tends to reduce the base shear force and its distribution thereof. This has been discussed in Chapter 19 of ASCE 7-10.

If this option is exercised, the effective shear is determined as

$$\bar{V} = V - \Delta V \tag{5.21}$$

The shear reduction,  $\Delta V$ , which should not exceed  $0.3V$ , is computed as follows:

$$V = \left[ C_s - \bar{C}_s \left( \frac{0.05}{\beta} \right)^{0.4} \right] \bar{W} \leq 0.3V \tag{5.22}$$

where

$V$  is base shear from Equation 5.10

$C_s$  is seismic response coefficient, Figure 5.7

$\bar{C}_s$  is seismic response coefficient from Figure 5.7 using the effective period  $\bar{T}$  for a flexibly supported structure.

$\beta$  is the fraction of critical damping for the structural foundation system. The building codes assume a minimum value of 0.05 and a maximum value of 0.2.

$\bar{W}$  is adjusted seismic weight of structure, which is taken as 0.7 times the weight of the structure except for a single level, when it is taken as the weight of structure.

$\bar{T}$  is effective period computed by a relation in ASCE 7-10 as a function of various stiffness parameters related to the foundation. It is higher than the fundamental period  $T_a$ .

**Example 5.6**

For Example 5.4, determine the base shear force accounting for the soil–structure interaction. The effective period is computed to be 0.3 seconds and the fraction of critical damping is 0.1.

## SOLUTION

1. From Example 5.4
  - $S_{DS} = 0.73$
  - $T_s = 0.59$  seconds
  - $I = 1.5$
  - $R = 5$
  - $C_s = 0.22$
  - $W = 621$  k
  - $V = 136.6$  k
2. Since  $\bar{T}$  of 0.3 s is  $< T_s$ ,  $\bar{C}_s = \frac{S_{DS}}{R/I} = \frac{0.73}{5/1.5} = 0.22$
3.  $\bar{W} = 0.7(621) = 434.7$  k
4.  $\bar{C}_s(0.05/0.1)^{0.4} = 0.22(0.5)^{0.4} = 0.167$
5. From Equation 5.22,  $\Delta V = (0.22 - 0.167)434.7 = 23.5$  k ← controls  
or  $\Delta V = 0.33 V = 0.3(136.6) = 41$  k
6. From Equation 5.21,  $\bar{V} = 136.6 - 23.5 = 113.1$  k

## PROBLEMS

- 5.1 Determine the approximate fundamental period for a five-story concrete office building with each floor having a height of 12 ft.
- 5.2 Determine the approximate fundamental period for a three-story wood-framed structure having a total height of 25 ft.
- 5.3 At a location in California, the mapped values of MCE accelerations  $S_s$  and  $S_1$  are 1.4  $g$  and 0.7  $g$ , respectively. The site soil class is C. The long-period transition period is 8 seconds. Prepare the design response acceleration curve for this location.
- 5.4 In Salt Lake City, Utah, the mapped values of  $S_s$  and  $S_1$  are 1.8  $g$  and 0.75  $g$ , respectively. The site soil class is B. The long-period transition period is 6 seconds. Prepare the design response acceleration curve.
- 5.5 For the five-story concrete office building from Problem 5.1 located in California with each floor having a height of 12 ft. where  $S_s$  and  $S_1$  are 1.4  $g$  and 0.7  $g$ , respectively, and the site soil class is C, determine (1) the SDC and (2) the seismic response coefficient. Assume  $R = 2.0$ .
- 5.6 For the three-story wood-framed commercial building from Problem 5.2 located in California of total height 25 ft., where  $S_s$  and  $S_1$  are 1.8  $g$  and 0.75  $g$ , respectively, and the soil group is B, determine (1) the SDC and (2) the seismic response coefficient. Assume  $R = 6.5$ .
- 5.7 A two-story office building, as shown in Figure P5.1, is located in Oregon where  $S_s = 1.05$   $g$  and  $S_1 = 0.35$   $g$ . The building has a plywood floor system and plywood sheathed shear walls ( $R = 6.5$ ). The soil in the foundation is very dense. The loads on the building are as follows:

Roof dead load (on the horizontal plane) = 20 psf

Floor dead load = 15 psf

Partition load = 15 psf

Exterior wall dead load = 50 psf

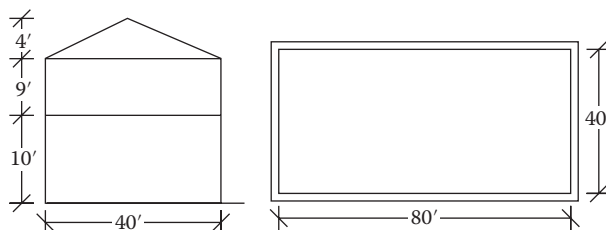


FIGURE P5.1 An office building in Oregon for Problem 5.7.

Determine the lateral and vertical earthquake loads that will act on the vertical elements of the building.

- 5.8 For the building from Problem 5.7, determine the earthquake loads that will act on the horizontal elements of the building.
- 5.9 Problem 5.5 has three stories—the first two stories are 8 ft. each and the top story is 9 ft. with a flat roof. It has a plan dimension of 120 × 60 ft. The roof and floor dead loads are 20 psf and the wall dead load is 60 psf. Determine the earthquake loads acting on the vertical members of the building.
- 5.10 For the building from Problem 5.9, determine the earthquake loads acting on the horizontal elements of the building.
- 5.11 A three-story industrial steel building (Figure P5.2) located where  $S_s$  and  $S_1$  are 0.61  $g$  and 0.18  $g$ , respectively, has a plan dimension of 200 × 90 ft. The structure consists of nine gable moment-resisting steel frames spanning 90 ft. at 25 ft. in the center;  $R = 4.5$ . The building is enclosed by insulated wall panels and is roofed with steel decking. The building is 36 ft. high and each floor height is 12 ft. The building is supported on spread roofing on medium dense sand (soil class D).

The steel roof deck is supported by joists at 5 ft. in the center, between the main gable frames. The flooring consists of the concrete slab over steel decking, supported by floor beams at 10 ft. in the center. The floor beams rest on girders that are attached to the gable frames at each end.

The following loads have been determined in the building:

Roof dead load (horizontal plane) = 15 psf

Third floor storage live load = 120 psf

Slab and deck load on each floor = 40 psf

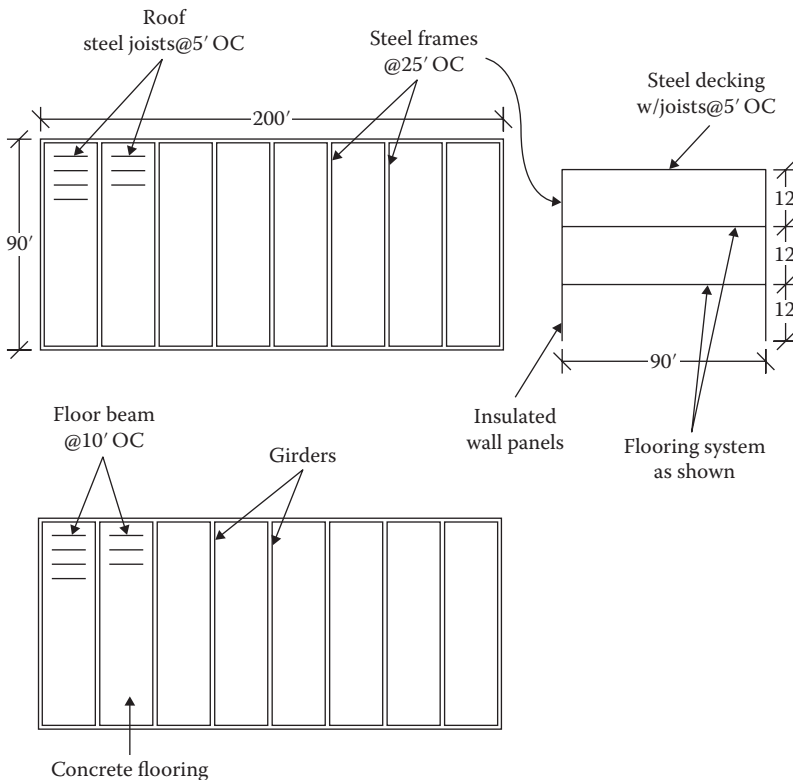


FIGURE P5.2 An industrial steel building for Problem 5.11.

Weight of each framing = 10 k

Weight of non-shear-resisting wall panels = 10 psf

Include 25% of the storage live load for seismic force. Since the wall panels are non-shear-resisting, these are not to be subtracted for  $F_{px}$ .

Determine the lateral and vertical earthquake loads acting on the vertical elements of the building.

- 5.12** For the building from Problem 5.11, determine the lateral and vertical earthquake loads acting on the horizontal elements of the building.
- 5.13** For Problem 5.7, determine the base shear force accounting for the soil–structure interaction. The effective period is computed to be 0.4 seconds. The damping factor is 0.1.
- 5.14** For Problem 5.9, determine the base shear force accounting for the soil–structure interaction. The effective period is computed to be 0.5 seconds. The damping factor is 0.1.
- 5.15** For Problem 5.11, determine the base shear force accounting for the soil–structure interaction. The effective period is computed to be 0.8 seconds. The damping factor is 0.05.





# *Section II*

---

## *Wood Structures*



---

# 6 Wood Specifications

## ENGINEERING PROPERTIES OF SAWN LUMBER

The *National Design Specification for Wood Construction* of the American Forest and Paper Association (2012 edition) provides the basic standards and specifications for sawn lumber and engineered wood (e.g., glued laminated timber [GLULAM]) in the United States. The second part of the National Design Specification (NDS), referred to as the NDS supplement, contains numerical values for the strength of different varieties of wood grouped according to the species of trees. Pieces of wood sawn from the same species or even the same source show a great variation in engineering properties. Accordingly, the lumber is graded to establish strength values. Pieces of lumber having similar mechanical properties are placed in the same class known as the *grade* of wood. Most lumber is visually graded. However, a small percentage is mechanically graded. In each grade, the relative size of wood section and the suitability of that size for a structural application are used as additional guides to establish the strength.

A lumber is referred to by its nominal size. However, the lumber used in construction is mostly dressed lumber. In other words, the lumber is surfaced to a net size, which is taken to be 0.5 in. less than the nominal size for sizes up to 6 in., 0.75 in. less for nominal sizes over 6 in. and below 16 in., and 1 in. less for sizes 16 in. and above. In the case of large sections, sometimes the lumber is rough sawed. The rough-sawed dimensions are approximately 1/8 in. larger than the dressed size.

Sawn lumber is classified according to size into (1) dimension lumber and (2) timber. Dimension lumber has smaller sizes. It has a nominal thickness of 2–4 in. and a width\* of 2–16 in. Thus, the sizes of dimension lumber range from 2 in. × 2 in. to 4 in. × 16 in. Timber has a minimum nominal thickness of 5 in.

Dimension lumber and timber are further subdivided based on the suitability of the specific size for use as a structural member. The size and use categorization of commercial lumber is given in Table 6.1. The sectional properties of standard dressed sawn lumber are given in Appendix B, Table B.1.

## REFERENCE DESIGN VALUES FOR SAWN LUMBER

The numerical values of permissible levels of stresses for design with respect to bending, tension, compression, shear, modulus of elasticity, and modulus of stability of a specific lumber are known as *reference design values*. These values are arranged according to the species. Under each species, size and use categories, as listed in Table 6.1, are arranged. For each size and use category, the reference design values are listed for different grades of lumber. Thus, design value may be different for the same grade name but in a different size category. For example, the select structural grade appears in SLP, SJ & P, beam and stringer (B & S), and post and timber (P & T) categories and the design values for a given species are different for the select structural grade in all of these categories.

The following reference design values are provided in tables:

Appendix B, Table B.2: Reference design values for dimension lumber other than Southern Pine

---

\* In the terminology of lumber grading, the smaller cross-sectional dimension is thickness and the larger dimension is width. In the designation of engineering design, the dimension parallel to the neutral axis of a section as placed is width and the dimension perpendicular to the neutral axis is depth. Thus, a member loaded about the strong axis (placed with the smaller dimension parallel to the neutral axis) has the width that is referred to as thickness in lumber terminology.

**TABLE 6.1**  
**Categories of Lumber and Timber**

Name	Symbol	Nominal Dimension	
		Thickness (Smaller Dimension)	Width
<b>A. Dimension Lumber</b>			
1. Light framing	LF	2–4 in.	2–4 in.
2. Structural light framing	SLF	2–4 in.	2–4 in.
3. Structural joist and plank	SJ & P	2–4 in.	5 in. or more
4. Stud		2–4 in.	2 in. or more
5. Decking		2–4 in.	4 in. or more
<b>B. Timber</b>			
1. Beam and stringer	B & S	5 in. or more	At least 2 in. more than thickness
2. Post and timber	P & T	5 in. or more	Not more than 2 in. more than thickness

Appendix B, Table B.3: Reference design values for Southern Pine dimension lumber

Appendix B, Table B.4: Reference design values for timber

Although reference design values are given according to the size and use combination, the values depend on the size of the member rather than its use. Thus, a section  $6 \times 8$  listed under the P & T category with its reference design values indicated therein can be used for B & S, but its design values as indicated for P & T will apply.

## ADJUSTMENTS TO THE REFERENCE DESIGN VALUES FOR SAWN LUMBER

The reference design values in the NDS tables are the basic values that are multiplied by many factors to obtain adjusted design values. To distinguish an adjusted value from a reference value, a prime notation is added to the symbol of the reference value to indicate that necessary adjustments have been made. Thus,

$$F'_{()} = F_{()} \times (\text{products of adjustment factors}) \quad (6.1)$$

The () is replaced by a property like tensile, compression, and bending.

For wood structures, allowable stress design (ASD) is a traditional basis of design. The load resistance factor design (LRFD) provisions were introduced in 2005. The reference design values given in NDS are based on ASD (i.e., these are permissible stresses). The reference design values for LRFD have to be converted from the ASD values.

To determine the nominal design stresses for LRFD, the reference design values of the NDS tables, as reproduced in the appendixes, are required to be multiplied by a format conversion factor,  $K_F$ . The format conversion factor serves a purpose that is reverse of the factor of safety, to obtain the nominal strength values for LRFD application. In addition, the format conversion factor includes the effect of load duration. It adjusts the reference design values of normal (10 years) duration to the nominal strength values for a short duration (10 minutes), which have better reliability.

In addition to the format conversion factor, a resistance factor,  $\phi$ , is applied to obtain the LRFD adjusted values. A subscript n is added to recognize that it is a nominal (strength) value for the LRFD design. Thus, the adjusted nominal design stress is expressed as follows:

$$F'_{(n)} = \phi F'_{()} K_F \quad (6.2)$$

The adjustment factors are discussed as follows:

1. The wet-service factor is applied when the wood in a structure is not in a dry condition, that is, its moisture content exceeds 19% (16% in the case of laminated lumber). Most structures use dry lumber for which  $C_M = 1$ .
2. The temperature factor is used if a prolonged exposure to higher than normal temperature is experienced by a structure. The normal condition covers the ordinary winter to summer temperature variations and the occasional heating up to 150°F. For normal conditions,  $C_t = 1$ .
3. Some species of wood do not accept a pressure treatment easily and require incisions to make the treatment effective. For dimension lumber only, a factor of 0.8 is applied to bending, tension, shear, and compression parallel to grains and a factor of 0.95 is applied to modulus of elasticity and modulus of elasticity for stability.
4. In addition, there are some special factors like column stability factor,  $C_p$ , and beam stability factor,  $C_L$ , that are discussed in the context of column and beam designs in Chapter 7.

The other adjustment factors that are frequently applied are discussed in the following sections.

### TIME EFFECT FACTOR,\* $\lambda$

Wood has the unique property that it can support a higher load when it is applied for a short duration. The nominal reference design values are representative of a short-duration loading. For a loading of long duration, the reference design values have to be reduced by a time effect factor. Different types of loads represent different load durations. Accordingly, the time effect factor depends on combinations of loads. For various load combinations, the time effect factor is given in Table 6.2. It should be remembered that the factor is applied to the nominal reference (stress) value and not to the load.

### SIZE FACTOR, $C_F$

The size of a wood section has an effect on its strength. The factor for size is handled differently for dimension lumber and for timber.

**TABLE 6.2**  
**Time Effect Factor**

Load Combination	$\lambda$
1.4D	0.6
1.2D + 1.6L + 0.5( $L_r$ or $S$ )	0.7 when $L$ is from storage 0.8 when $L$ is from occupancy 1.25 when $L$ is from impact
1.2D + 1.6( $L_r$ or $S$ ) + ( $fL$ or 0.5W)	0.8
1.2D + 1.0W + $fL$ + 0.5( $L_r$ or $S$ )	1.0
1.2D + 1.0E + $fL$ + 0.2S	1.0
0.9D + 1.0W	1.0
0.9D + 1.0E	1.0

Note:  $f = 0.5$  for  $L \leq 100$  psf; otherwise  $f = 1$ .

\* The time effect factor is relevant only to load resistance factor design. For allowable stress design, this factor, known as the *load duration factor*,  $C_D$ , has different values.

### Size Factor, $C_F$ , for Dimension Lumber

For visually graded dimension lumber, the size factors for species other than Southern Pine are presented together with reference design values in Appendix B, Table B.2. For visually graded Southern Pine dimension lumber, the factors are generally built into the design values except for the bending values for 4 in. thick (breadth) dimension lumber. The factors for Southern Pine dimension lumber are given together with reference design values in Appendix B, Table B.3. No size factor adjustment is required for mechanically graded lumber.

### Size Factor, $C_F$ , for Timber

For timber sections exceeding a depth of 12 in., a reduction factor is applied only to bending as follows:

$$C_F = \left( \frac{12}{d} \right)^{1/9} \quad (6.3)$$

where  $d$  is dressed depth of the section.

### REPETITIVE MEMBER FACTOR, $C_r$

The repetitive member factor is applied only to dimension lumber and that also only to the bending strength value. A repetitive member factor  $C_r = 1.15$  is applied when all of the following three conditions are met:

1. The members are used as joists, truss chords, rafters, studs, planks, decking, or similar members that are joined by floor, roof, or other load-distributing elements.
2. The members are in contact or are spaced not more than 24 in. on center (OC).
3. The members are not less than three in number.

The reference design values for decking are already multiplied by  $C_r$ . Hence, this factor is not shown in Table 6.3 under decking.

### FLAT USE FACTOR, $C_{fu}$

The reference design values are for bending about the major axis, that is, the load is applied on to the narrow face. The flat use factor refers to members that are loaded about the weak axis, that is, the load is applied on the wider face. The reference value is increased by a factor  $C_{fu}$  in such cases.

This factor is applied only to bending to dimension lumber and to bending and  $E$  and  $E_{min}$  to timber.

The values of  $C_{fu}$  are listed along with the reference design values in Appendix B, Tables B.2 through B.4.

### BUCKLING STIFFNESS FACTOR, $C_T$

This is a special factor that is applied when all of the following conditions are satisfied: (1) it is a compression chord of a truss, (2) made of a  $2 \times 4$  or smaller sawn lumber, (3) is subjected to combined flexure and axial compression, under dry condition, and (5) has  $\frac{3}{8}$  in. or thicker plywood sheathing nailed to the narrow face of the chord of the truss.

For such a case, the  $E_{min}$  value in the column stability,  $C_p$  calculations, is allowed to be increased by the factor  $C_T$ , which is more than 1. Conservatively, this can be taken as 1.

### BEARING AREA FACTOR, $C_b$

This is a special factor applied only to the compression reference design value perpendicular to grain,  $F_{c\perp}$ . This is described in Chapter 7 for support bearing cases.

**FORMAT CONVERSION FACTOR,  $K_F$** 

The format conversion factors for different types of stresses are reproduced in Table 6.3 from Table N1 of the NDS.

**RESISTANCE FACTOR,  $\phi$** 

The resistance factor, also referred to as the *strength reduction factor*, is used to account for all uncertainties whether related to the materials manufacturing, structural construction, or design computations that may cause actual values to be less than theoretical values. The resistance factor, given in Table 6.4, is a function of the mode of failure. The applicable factors for different loadings and types of lumber are summarized in Table 6.5.

**LOAD RESISTANCE FACTOR DESIGN WITH WOOD**

As discussed in the “Working Stress, Strength Design, and Unified Design of Structures” section in Chapter 1, LRFD designs are performed at the strength level in terms of force and moment. Accordingly, the adjusted nominal design stress values from the “Reference Design Values for Sawn Lumber” section are changed to strength values by multiplying them by the cross-sectional area or the section modulus. Thus, the basis of design in LRFD is as follows:

$$\text{Bending: } M_u = \phi M_n = F'_b S = \phi F_b \lambda C_M C_t C_F C_r C_{fu} C_i (C_L) K_F S \quad (6.4)$$

$$\text{Tension: } T_u = \phi T_n = \phi F_t \lambda C_M C_t C_F C_i K_F A \quad (6.5)$$

**TABLE 6.3**  
**Conversion Factor for Stresses**

Application	Property	$K_F$
Member	Bending $F_b$	2.54
	Tension $F_t$	2.7
	Shear $F_v$ , radial tension $F_{rt}$	2.88
	Compression $F_c$	2.4
	Compression perpendicular to grain $F_{c\perp}$	1.67
	$E_{min}$	1.76
	$E$	1.0
All connections	All design values	3.32

**TABLE 6.4**  
**Resistance Factor,  $\phi$**

Application	Property	$\phi$
Member	$F_b$	0.85
	$F_t$	0.80
	$F_v, F_{rt}$	0.75
	$F_c, F_{c\perp}$	0.9
	$E_{min}$	1.76
All connections	All design values	0.65

**TABLE 6.5**  
**Applicability of Adjustment Factors for Sawn Lumber**

Loading Condition	Type of Lumber	Factor							Special Factor			
		Time Effect	Size Effect	Repetitive	Wet Service	Temperature	Incision	Flat Use	Beam Stability	Column Stability	Buckling Stiffness	Bearing Area
Bending	Dimension lumber:	$\lambda$	$C_F$	$C_r$	$C_M$	$C_t$	$C_i$	$C_{fu}$	$C_L$			
	visually graded											
Tension	Dimension lumber:	$\lambda$		$C_r$	$C_M$	$C_t$	$C_i$	$C_{fu}$	$C_L$			
	mechanically graded											
Compression—parallel to grain	Timber	$\lambda$	$C_F$		$C_M$	$C_t$		$C_{fu}$	$C_L$			
	Decking	$\lambda$	$C_F$		$C_M$	$C_t$			$C_L$			
Compression—normal to grain	Dimension lumber	$\lambda$	$C_F$		$C_M$	$C_t$	$C_i$			$C_p$		
	Dimension lumber	$\lambda$	$C_F$		$C_M$	$C_t$	$C_i$			$C_p$		
Shear parallel to grain	Timber	$\lambda$			$C_M$	$C_t$						
	Both	$\lambda$			$C_M$	$C_t$	$C_i$				$C_b$	
Modulus of elasticity	Both				$C_M$	$C_t$	$C_i$					
	Both				$C_M$	$C_t$	$C_i$	<sup>a</sup>			$C_T$	
Modulus of elasticity for stability	Both				$C_M$	$C_t$	$C_i$	<sup>a</sup>				
	Both				$C_M$	$C_t$	$C_i$	<sup>a</sup>				

<sup>a</sup> Only for timber of structural #1, a  $C_{fu}$  of 0.9 is applied to  $E$  and  $E_{min}$  (in addition to table values for  $F_b$ ). For all other species of timber,  $C_{fu}$  is 1 for  $E$  and  $E_{min}$ .



$$\text{Compression: } P_u = \phi P_n = \phi F_c \lambda C_M C_t C_i C_F C_i (C_P) K_F A \quad (6.6)$$

$$P_{u\perp} = \phi P_n = \phi F_{c\perp} \lambda C_M C_t C_i C_b K_F A \quad (6.7)$$

$$\text{Shear: } V_u = \phi V_n = \phi F_v \lambda C_M C_t C_i K_F \left( \frac{2}{3} A^* \right) \quad (6.8)$$

$$\text{Stability: } E_{min(n)} = \phi E_{min} C_M C_t C_i C_T K_F \quad (6.9)$$

$$\text{Modulus of elasticity: } E_{(n)} = E C_M C_t C_i \quad (6.10)$$

The left-hand side (LHS) in the aforementioned equations represent the factored design loads combination and the factored design moments combination.

The design of an element is an iterative procedure since the reference design values and the modification factors in many cases are a function of the size of the element that is to be determined. Initially, the nominal design value could be assumed to be one-and-a-half times the basic reference design value for the smallest listed size of the specified species from the Tables B.2 through B.4 in Appendix B.

### Example 6.1

Determine the adjusted nominal reference design values and the nominal strength capacities of the Douglas Fir-Larch #1 2 in. × 8 in. roof rafters at 18 in. on center (OC) that support dead and roof live loads. Consider dry-service conditions, normal temperature range, and no-incision application.

### SOLUTION

1. The reference design values of a Douglas Fir-Larch #1 2 in. × 8 in. section are obtained from Appendix B, Table B.2.
2. The adjustment factors and the adjusted nominal reference design values are computed in the following table:

Property	Reference Design Value (psi)	Adjustment Factors					$F'_{0n}$ (psi)
		$\phi$	$\lambda$ for $D + L_r$	$C_F$	$C_r$	$K_F$	
Bending	1000	0.85	0.8	1.2	1.15	2.54	2383.54
Tension	675	0.80	0.8	1.2		2.7	1399.68
Shear	180	0.75	0.8			2.88	311.04
Compression	1500	0.9	0.8	1.05		2.40	2721.6
Compression $\perp$	625	0.9	0.8			1.67	751.5
$E$	$1.7 \times 10^6$						$1.7 \times 10^6$
$E_{min}$	$0.62 \times 10^6$	0.85				1.76	$0.93 \times 10^6$

3. Strength capacities

For a 2 in. × 8 in. section,  $S = 13.14 \text{ in.}^3$  and  $A = 10.88 \text{ in.}^2$

$$M_u = F'_{bn} S = (2383.54)(13.14) = 31319.66 \text{ in.}\cdot\text{lb}$$

$$T_u = F'_{tn} A = (1399.68)(10.88) = 15228.52 \text{ lb}$$

$$V_u = F'_{vn} (2A/3) = (311.04)(2 \times 10.88/3) = 2257.21 \text{ lb}$$

$$P_u = F'_{cn} A = (2721.6)(10.88) = 29611 \text{ lb}$$

\*  $\tau_{\max} = \frac{3V}{2A}$  or  $V = \tau_{\max} \left( \frac{2}{3} A \right)$

### Example 6.2

Determine the adjusted nominal reference design values and the nominal strength capacities of a Douglas Fir-Larch #1 6 in. × 16 in. floor beam supporting a combination of loads comprising dead, live, and snow loads. Consider dry-service conditions, normal temperature range, and no-incision application.

### SOLUTION

1. The reference design values of Douglas Fir-Larch #1 6 in. × 16 in. beams and stringers are from Appendix B, Table B.4.
2. The adjustment factors and the adjusted nominal reference design values are given in the following table:

Property	Reference Design Value (psi)	Adjustment Factors				$F'_{0n}$ (psi)
		$\phi$	$\lambda$ for $D, L, S$	$C_F^a$	$K_F$	
Bending	1350	0.85	0.8	0.976	2.54	2275.76
Tension	675	0.80	0.8		2.70	1166.4
Shear	170	0.75	0.8		2.88	293.8
Compression	925	0.9	0.8		2.4	1598.4
$E$	$1.6 \times 10^6$					$1.6 \times 10^6$
$E_{min}$	$0.58 \times 10^6$	0.85			1.76	$0.87 \times 10^6$

<sup>a</sup>

$$C_F = \left(\frac{12}{d}\right)^{1/9} = \left(\frac{12}{15}\right)^{1/9} = 0.976.$$

3. Strength capacities

For the 6 in. × 16 in. section,  $S = 206.3 \text{ in.}^3$  and  $A = 82.5 \text{ in.}^2$

$$M_u = F'_{bn}S = (2275.76)(206.3) = 469,489 \text{ in.}\cdot\text{lb}$$

$$T_u = F'_{tn}A = (1166.4)(82.5) = 96,228 \text{ lb}$$

$$V_u = F'_{vn}(2A/3) = (293.8)(2 \times 82.5/3) = 16,167 \text{ lb}$$

$$P_u = F'_{cn}A = (1598.4)(82.5) = 131,868 \text{ lb}$$

### Example 6.3

Determine the unit load (per square foot load) that can be imposed on a floor system consisting of 2 in. × 6 in. Southern Pine select structural joists spaced at 24 in. OC spanning 12 ft. Assume that the dead load is one-half of the live load. Ignore the beam stability factor.

### SOLUTION

1. For Southern Pine 2 in. × 6 in. select structural dressed lumber, the reference design value is

$$F_b = 2550 \text{ psi.}$$

2. Size factor is included in the tabular value.
3. Time effect factor for dead and live loads = 0.8
4. Repetitive factor = 1.15
5. Format conversion factor = 2.54
6. Resistance factor = 0.85
7. Nominal reference design value

$$\begin{aligned} F'_{bn} &= \phi F_b \lambda C_M C_t C_i C_r C_F C_{fu} K_F \\ &= 0.85(2250)(0.8)(1)(1)(1)(1.15)(1)(1)(2.54) = 5065 \text{ psi} \end{aligned}$$

8. For 2 in.  $\times$  6 in.,  $S = 7.56 \text{ in.}^3$
9.  $M_u = F'_{bn}S = (5065)(7.56) = 38291.4 \text{ in.}\cdot\text{lb}$  or 3191 ft. $\cdot$ lb
10.  $M_u = \frac{w_u L^2}{8}$   
 or  
 $w_u = \frac{8M_u}{L^2} = \frac{8(3191)}{(12)^2} = 177.3 \text{ lb/ft.}$
11. Tributary area per foot of joists =  $\frac{24}{12} \times 1 = 2 \text{ ft.}^2/\text{ft.}$
12.  $w_u = (\text{Design load per square foot})(\text{Tributary area per square foot})$   
 $177.3 = (1.2D + 1.6L)(2)$   
 or  
 $177.3 = [1.2D + 1.6(2D)](2)$   
 or  
 $D = 20.15 \text{ lb/ft.}^2$   
 and  
 $L = 40.3 \text{ lb/ft.}^2$

### Example 6.4

For a Southern Pine #1 floor system, determine the size of joists at 18 in. OC spanning 12 ft. and the column receiving loads from an area of 100 ft.<sup>2</sup> acted upon by a dead load of 30 psf and a live load of 40 psf. Assume that the beam and column stability factors are not a concern.

### SOLUTION

#### A. Joist design

- Factored unit combined load =  $1.2(30) + 1.6(40) = 100 \text{ psf}$
- Tributary area/ft. =  $(18/12) \times 1 = 1.5 \text{ ft.}^2/\text{ft.}$
- Design load/ft.  $w_u = 100(1.5) = 150 \text{ lb/ft.}$
- $M_u = \frac{w_u L^2}{8} = \frac{(150)(12)^2}{8} = 2,700 \text{ ft.}\cdot\text{lb}$  or 32,400 in. $\cdot$ lb
- For a trial section, select the reference design value of a 2–4 in. wide section and assume the nominal reference design value to be one-and-a-half times the table value.  
 From Appendix B, Table B.3, for Southern Pine #1,  $F_b = 1850 \text{ psi}$   
 Nominal reference design value =  $1.5(1850) = 2775 \text{ psi}$
- Trial size

$$S = \frac{M_u}{F'_{bn}} = \frac{32,400}{2,775} = 11.68 \text{ in.}^3$$

Use 2 in.  $\times$  8 in.  $S = 13.14 \text{ in.}^3$

- From Appendix B, Table B.3,  $F_b = 1500 \text{ psi}$
- Adjustment factors  
 $\lambda = 0.8$   
 $C_r = 1.15$   
 $K_F = 2.54$   
 $\phi = 0.85$
- Adjusted nominal reference design value  
 $F'_{bn} = 0.85(1500)(0.8)(1.15)(2.54) = 2979.4 \text{ psi}$

10.  $M_u = F'_{bn}S$   
 or  
 $S_{reqd} = \frac{M_u}{F'_{bn}} = \frac{32,400}{2,979.4} = 10.87 \leq 13.14 \text{ in.}^3$

The selected size 2 in.  $\times$  8 in. is **OK**.

B. Column design

1. Factored unit load (step A.1) = 100 psf
2. Design load = (unit load)(tributary area)  
= (100)(100) = 10,000 lb
3. For a trial section, select the reference design value of a 2–4 in. wide section and assume the nominal reference design value to be one-and-a-half times of the table value.

From Appendix B, Table B.3, for Southern Pine #1,  $F_c = 1850$  psi

Nominal reference design value =  $1.5(1850) = 2775$  psi

4. Trial size

$$A = \frac{P_u}{F'_{cn}} = \frac{10,000}{2,775} = 3.6 \text{ in.}^2$$

Use 2 in. × 4 in.  $A = 5.25 \text{ in.}^2$

5.  $F_b = 1850$  psi  
 $\lambda = 0.8$   
 $K_F = 2.40$   
 $\phi = 0.90$
6. Adjusted nominal reference design value

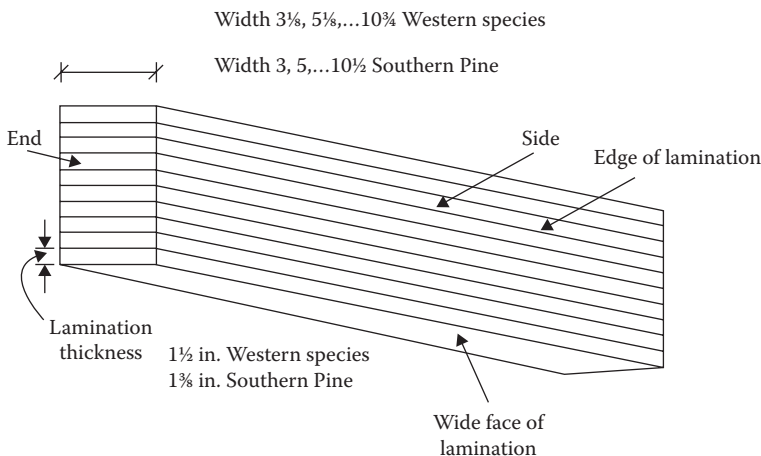
$$F'_{cn} = 0.9(1,850)(0.8)(2.4) = 3,196.8 \text{ psi}$$

$$A_{reqd} = \frac{P_u}{F'_{cn}} = \frac{10,000}{3,196.8} = 3.13 < 5.25 \text{ in.}^2$$

The selected size 2 in. × 4 in. is **OK**.

**STRUCTURAL GLUED LAMINATED TIMBER**

GLULAM members are composed of individual pieces of dimension lumber that are bonded together by an adhesive to create required sizes. For western species, the common widths\* (breadth) are  $3\frac{1}{8}$ ,  $5\frac{1}{8}$ ,  $6\frac{3}{4}$ ,  $8\frac{3}{4}$ ,  $10\frac{3}{4}$ , and  $12\frac{1}{2}$  in. (there are other interim sections as well). The laminations are typically in  $1\frac{1}{2}$  in. incremental depth. For Southern Pine, the common widths are 3, 5,  $6\frac{3}{4}$ ,  $8\frac{1}{2}$ , and  $10\frac{1}{2}$  in. and the depth of each lamination is  $1\frac{3}{8}$  in. Usually, the lamination of GLULAM is horizontal (the wide faces are horizontally oriented). A typical cross section is shown in Figure 6.1.



**FIGURE 6.1** A structural glued laminated (GLULAM) section.

\* Not in terms of lumber grading terminology.

The sectional properties of western species structural GLULAM are given in Appendix B, Table B.5 and those of Southern Pine structural GLULAM in Appendix B, Table B.6.

Because of their composition, large GLULAM members can be manufactured from smaller trees from a variety of species such as Douglas Fir, Hem Fir, and Southern Pine. GLULAM has much greater strength and stiffness than sawn lumber.

## REFERENCE DESIGN VALUES FOR GLUED LAMINATED TIMBER

The reference design values for GLULAM are given in Appendix B, Table B.7 for members stressed primarily in bending (beams) and in Appendix B, Table B.8 for members stressed primarily in axial tension or compression.

Appendix B, Table B.7 related to bending members is a summary table based on the stress class. The first part of the stress class symbol refers to the bending stress value for the grade in hundreds of pounds per square inch followed by the letter F. For example, 24F indicates a bending stress of 2400 psi for normal duration loaded in the normal manner, that is, loads are applied perpendicular to the wide face of lamination. The second part of the symbol is the modulus of elasticity in millions of pounds per square inch. Thus, 24F-1.8E indicates a class with the bending stress in 2400 psi and the modulus of elasticity in  $1.8 \times 10^6$  psi. For each class, the NDS provide the expanded tables that are organized according to the combination symbol and the types of species making up the GLULAM. The first part of the combination symbol is the bending stress level, that is, 24F referring to 2400 psi bending stress. The second part of the symbol refers to the lamination stock: V standing for visually graded and E for mechanically graded or E-rated. Thus, the combination symbol 24F-V5 refers to the grade of 2400 psi bending stress of visually graded lumber stock. Under this, species are indicated by abbreviations, that is, DF for Douglas Fir, SP for Southern Pine, and HF for Hem Fir.

The values listed in Appendix B, Table B.7 are more complex than those for sawn lumber. The first six columns are the values for bending about the strong ( $x-x$ ) axis when the loads are perpendicular to the wide face of lamination. These are followed up values for bending about the  $y-y$  axis. The axially loaded values are also listed in case the member is picked up for the axial load conditions.

For  $F_{bx}$ , two values have been listed in columns 1 and 2 of Appendix B, Table B.7 (for bending) as  $F_{bx}^+$  and  $F_{bx}^-$ . In a rectangular section, the compression and tension stresses are equal in extreme fibers. However, it has been noticed that the outer tension laminations are in a critical state and, therefore, high-grade laminations are placed at the bottom of the beam, which is recognized as the tensile zone of the beam. The other side is marked as the *top* of the beam in the lamination plant. Placed in this manner, the portion marked top is subjected to compression and the bottom to tension. This is considered as the condition in which the designated tension zone is stressed in tension and the  $F_{bx}^+$  value of the first column is used for bending stress. This is a common condition.

However, if the beam is installed upside down or in the case of a continuous beam for which the negative bending moment condition develops, that is, the top fibers are subject to tension, the reference values in the second column known as the designated compression zone stressed in tension,  $F_{bx}^-$ , should be used.

Appendix B, Table B.8 lists the reference design values for principally axially load-carrying members. Here, members are identified by numbers, such as 1, 2, and 3, followed by species such as DF, HF, and SP, and by grade. The values are not complex like those in Appendix B, Table B.7 (the bending case).

It is expected that members with the bending combination in Appendix B, Table B.7 will be used as beams, as they make efficient beams. However, it does not mean that they cannot be used

for axial loading. Similarly, an axial combination member can be used for a beam. The values with respect to all types of loading modes are covered in both tables (Appendix B, Tables B.7 and B.8).

## ADJUSTMENT FACTORS FOR GLUED LAMINATED TIMBER

The reference design values of Appendix B, Tables B.7 and B.8 are applied by the same format conversion factors and time effect factors as discussed in the “Adjustments to the Reference Design Values for Sawn Lumber” section.

Additionally, the other adjustment factors listed in Table 6.6 are applied to structural GLULAM.

For GLULAM, when moisture content is more than 16% (as against 19% for sawn lumber), the wet-service factor is specified in a table in the NDS. The values are different for sawn lumber and GLULAM. The temperature factor is the same for GLULAM as for sawn lumber.

The beam stability factor,  $C_L$ , column stability factor,  $C_p$ , and bearing area factor,  $C_b$ , are the same as for the sawn lumber. However, some other factors that are typical to GLULAM are described in the following sections.

### FLAT USE FACTOR FOR GLUED LAMINATED TIMBER, $C_{fu}$

The flat use factor is applied to the reference design value only (1) for the case of bending that is loaded parallel to laminations and (2) if the dimension parallel to the wide face of lamination (depth in flat position) is less than 12 in. The factor is

$$C_{fu} = \left(\frac{12}{d}\right)^{1/9} \quad (6.11)$$

where  $d$  is depth of the section.

Equation 6.11 is similar to the size factor (Equation 6.3) of sawn timber lumber.

### VOLUME FACTOR FOR GLUED LAMINATED TIMBER, $C_v$

The volume factor is applied to bending only for horizontally laminated timber for loading applied perpendicular to laminations (bending about the  $x$ - $x$  axis); it is applied to  $F_{bx}^+$  and  $F_{bx}^-$ . The beam stability factor,  $C_L$ , and the volume factor,  $C_v$ , are not used together; only the smaller of the two is applied to adjust  $F_{bm}'$ . The concept of the volume factor for GLULAM is similar to the size factor for sawn lumber because test data have indicated that the size effect extends to volume in the case of GLULAM. The volume factor is

$$C_v = \left(\frac{5.125}{b}\right)^{1/x} \left(\frac{12}{d}\right)^{1/x} \left(\frac{21}{L}\right)^{1/x} \leq 1 \quad (6.12)$$

where

$b$  is width (in inches)

$d$  is depth (in inches)

$L$  is length of member between points of zero moments (in feet)

$x = 20$  for Southern Pine and 10 for other species

### CURVATURE FACTOR FOR GLUED LAMINATED TIMBER, $C_c$

The curvature factor is applied to bending stress only to account for the stresses that are introduced in laminations when they are bent into curved shapes during manufacturing. The curvature factor is

$$C_c = 1 - 2000 \left(\frac{t}{R}\right)^2 \quad (6.13)$$

**TABLE 6.6**  
**Applicability of Adjustment Factors for GLULAM**

Loading Condition	Loading Case	Factor					Special Factor					
		Time Effect	Wet Service	Temperature	Size (Volume)	Flat Use	Curvature	Beam Stability	Column Stability	Stress Interaction	Shear Reduction	Bearing Area
Bending	Load perpendicular to lamination	$\lambda$	$C_M$	$C_T$	$C_V$		$C_c$	$C_L$ (or $C_p$ )		$C_I$		
	Load parallel to lamination	$\lambda$	$C_M$	$C_T$		$C_{fu}$	$C_c$	$C_L$		$C_I$		
Tension Compression	Load parallel to grain	$\lambda$	$C_M$	$C_T$								
	Load perpendicular to grain	$\lambda$	$C_M$	$C_T$				$C_p$				$C_b$
Shear Modulus of elasticity Modulus of elasticity for stability		$\lambda$	$C_M$	$C_T$							$C_{vr}$	
			$C_M$	$C_T$								
			$C_M$	$C_T$								

where

$t$  is thickness of the lamination,  $1\frac{1}{2}$  in. or  $1\frac{3}{8}$  in.

$R$  is radius of curvature of the inside face of the lamination

The ratio  $t/R$  may not exceed  $1/100$  for Southern Pine and  $1/125$  for other species. The curvature factor is not applied to the straight portion of a member regardless of curvature in the other portion.

**STRESS INTERACTION FACTOR,  $C_I$**

This is applied only (1) to the tapered section of a member and (2) to the reference bending stress. For members tapered in compression, either  $C_I$  or the volume factor  $C_v$  is applied, whichever is smaller. For members tapered on tension face, either  $C_I$  or the beam stability factor  $C_L$  is applied, whichever is smaller.

The factor depends on the angle of taper, bending stress, shear stress, and compression stress perpendicular to grains for compression face taper and radial tensile stress for tensile face taper. It is less than 1. A reference is made to Section 5.3.9 of NDS 2012.

**SHEAR REDUCTION FACTOR,  $C_{vr}$**

The reference shear design values  $F_{vx}$  and  $F_{vy}$  are multiplied by a factor  $C_{vr} = 0.72$  when any of the following conditions apply:

1. Nonprismatic members
2. Members subject to impact or repetitive cyclic loading
3. Design of members at notches
4. Design of members at connections

**Example 6.5**

Determine the adjusted nominal reference design stresses and the strength capacities of a  $6\frac{3}{4}$  in.  $\times$  18 in. GLULAM from Douglas Fir-Larch of stress class 24F-1.7E, used primarily for bending. The span is 30 ft. The loading consists of the dead load and live load combination along the major axis.

**SOLUTION**

1. The adjusted reference design values are computed in the following table:

Property	Reference Design Value (psi)	Adjustment Factors				$F'_{0n}$ (psi)
		$\phi$	$\lambda$	$C_v$	$K_F$	
Bending	2400	0.85	0.8	0.90 <sup>a</sup>	2.54	3730.75
Tension	775	0.8	0.8		2.7	1339.2
Shear	210	0.75	0.8		2.88	362.88
Compression	1000	0.9	0.8		2.4	1728.0
$E$	$1.7 \times 10^6$					$1.7 \times 10^6$
$E_{min}$	$0.88 \times 10^6$	0.85			1.76	$1.32 \times 10^6$

<sup>a</sup>  $C_v = \left(\frac{5.125}{6.75}\right)^{1/10} \left(\frac{12}{18}\right)^{1/10} \left(\frac{21}{30}\right)^{1/10} = 0.90$



## 2. Strength capacities:

For the  $6\frac{3}{4}$  in.  $\times$  18 in. section,  $S_x = 364.5 \text{ in.}^3$ ,  $A = 121.5 \text{ in.}^2$

Bending:  $\phi M_n = F'_{bn} S = (3730.75)(364.5) = 1.36 \times 10^6 \text{ in.}\cdot\text{lb}$

Tension:  $\phi T_n = F'_n A = (1339.2)(121.5) = 162.71 \times 10^3 \text{ lb}$

Shear:  $\phi V_n = F'_{vn} (2/3 A) = (362.88)(2/3 \times 121.5) = 29.39 \times 10^3 \text{ lb}$

Compression:  $\phi P_n = F'_{cn} A = (1728)(121.5) = 210 \times 10^3 \text{ lb}$

**Example 6.6**

The beam in Example 6.5 is installed upside down. Determine the design strengths.

**SOLUTION**

1. The bending reference design value for a compression zone stressed in tension = 1450 psi from Appendix B, Table B.7
2. Adjustment factors from Example 6.5

$$\Phi = 0.85$$

$$\lambda = 0.80$$

$$C_v = 0.90$$

$$K_F = 2.54$$

3. Adjusted nominal design value

$$F'_{bn} = 0.85(1450)(0.8)(0.9)(2.54) = 2254 \text{ psi}$$

4. Strength capacity

$$F'_{bn} S = (2254)(364.5) = 0.882 \times 10^6 \text{ in.}\cdot\text{lb}$$

5. The other values are the same as in Example 6.5.

**Example 6.7**

The beam used in Example 6.5 is flat with loading along the minor axis. Determine the design strengths.

**SOLUTION**

1. The adjusted reference design values are computed in the following table:

Property	Reference Design Value (psi)	Adjustment Factors				$F'_{0n}$ (psi)
		$\phi$	$\lambda$	$C_{fu}$	$K_F$	
Bending	1050	0.85	0.8	1.066 <sup>a</sup>	2.54	1933.26
Tension	775	0.8	0.8		2.7	1339.2
Shear	185	0.75	0.8		2.88	319.68
Compression	1000	0.9	0.8		2.4	1728.0
$E$	$1.3 \times 10^6$					$1.3 \times 10^6$
$E_{min}$	$0.67 \times 10^6$	0.85			1.76	$1.00 \times 10^6$

<sup>a</sup>  $C_{fu} = \left(\frac{12}{6.75}\right)^{1/9} = 1.066$

## 2. Strength capacities

For the 6¾ in. × 18 in. section,  $S_y = 136.7 \text{ in.}^3$ ,  $A = 121.5 \text{ in.}^2$

Bending:  $\phi M_n = F'_{bn} S = (1933.26)(136.7^*) = 0.26 \times 10^6 \text{ in.}\cdot\text{lb}$

Tension:  $\phi T_n = F'_{tn} A = (1339.2)(121.5) = 162713 \text{ lb}$

Shear:  $\phi V_n = F'_{vn} (2/3 A) = (319.68)(2/3 \times 121.5) = 25.89 \times 10^3 \text{ lb}$

Compression:  $\phi P_n = F'_{cn} A = (1728)(121.5) = 209 \times 10^3 \text{ lb}$

**Example 6.8**

What are the unit dead and live loads (per square foot) resisted by the beam in Example 6.5 that is spaced 10 ft. OC? Assume that the unit dead load is one-half of the live load.

**SOLUTION**

1. From Example 6.5,

$$M_u = \phi M_n = 1.36 \times 10^6 \cdot \text{lb} \text{ or } 113,333.3 \text{ ft.}\cdot\text{lb}$$

$$2. M_u = 113,333.33 = \frac{w_u L^2}{8}$$

or

$$w_u = \frac{113,333.33(8)}{(30)^2} = 1,007.41 \text{ lb/ft.}$$

3. Tributary area per foot of the beam =  $10 \times 1 = 10 \text{ ft.}^2/\text{ft.}$

$$w_u = (\text{Design load}/\text{ft.}^2)(\text{Tributary area, ft.}^2/\text{ft.})$$

$$1007.41 = (1.2D + 1.6L)(10)$$

or

$$1007.41 = [1.2D + 1.6(2D)](10)$$

or

$$D = 22.9 \text{ lb/ft.}^2$$

and

$$L = 45.8 \text{ lb/ft.}^2$$

**STRUCTURAL COMPOSITE LUMBER**

Structural composite lumber (SCL) is an engineered product manufactured from smaller logs. The manufacturing process involves sorting and aligning strands or veneer, applying adhesive, and bonding under heat and pressure. Stranding is making 3–12 in. slices of a log similar to grating a block of cheese. Veneering is rotary peeling by a knife placed parallel to the outer edge of a spinning log. The log is peeled from outside toward the center similar to removing paper towels from a roll. The slices cut into sheets are called veneer.

The following are four common types of SCL products:

1. Laminated strand lumber
2. Oriented strand lumber
3. Laminated veneer lumber (LVL)
4. Parallel strand lumber

\*  $S_y$  value.

The first two of these are strand products and the last two are veneer products. Proprietary names, such as Microlam and Parallam, are used to identify the aforementioned products.

The lamination of SCL is vertical (wide faces of laminations are oriented vertically) compared to the horizontal lamination of GLULAM (wide faces are oriented horizontally). The strength and stiffness of SCL is generally higher than that of GLULAM.

The typical reference design values for SCL are listed in Appendix B, Table B.9. SCL is equally strong flatwise and edgewise in bending. Several brands of SCL are available. The reference values and technical specifications for a specific brand might be obtained from the manufacturer's literature.

The same time effect factors and format conversion factors are applied to the reference design values of SCL as for sawn lumber and GLULAM, as discussed in the "Adjustments to the Reference Design Values Sawn Lumber" section.

In addition, the adjustment factors listed in Table 6.7 are applied to SCL. The wet-service factors,  $C_M$ , and the temperature factors,  $C_T$ , are the same for GLULAM and SCL. To the members used in repetitive assembly, as defined in the "Repetitive Member Factor,  $C_r$ " section of sawn lumber, a repetitive factor,  $C_r$ , of 1.04 is applied.

The value of the size (volume) factor,  $C_v$ , is obtained from the SCL manufacturer's literature. When  $C_v \leq 1$ , only the lesser of the volume factor,  $C_v$ , and the beam stability factor,  $C_L$ , is applied. However, when  $C_v > 1$  both the volume factor and the beam stability factor are used together.\*

## SUMMARY OF ADJUSTMENT FACTORS

### A. Common to sawn lumber, GLULAM, and SCL

1. Time effect,  $\lambda \leq 1$
2. Temperature,  $C_t \leq 1$
3. Wet service,  $C_M \leq 1$
4. Format conversion,  $K_F > 1$
5. Resistance factor,  $\phi < 1$
6. Beam stability factor,  $C_L$  (applied to  $F_b$  only)  $\leq 1$
7. Column stability factor,  $C_P$  (applied only to  $F_c$  parallel to grain)  $\leq 1$
8. Bearing area factor,  $C_b$  (applied only to  $F_c$  perpendicular to grain)  $\geq 1$

### B. Sawn lumber

1. Incision factor,  $C_i \leq 1$
2. Size factor,  $C_F \leq 1$
3. Repetitive factor,  $C_r = 1.15$
4. Flat use factor,  $C_{fu}$  (applied only to  $F_b$ ) for dimension  $\geq 1$ , for timber  $\leq 1$

### C. GLULAM

1. Volume factor,  $C_v \leq 1$
2. Curvature factor,  $C_c \leq 1$
3. Flat use factor,  $C_{fu}$  (applied only to  $F_b$ ) for GLULAM  $\geq 1$

### D. SCL

1. Volume factor,  $C_v \leq 1$  or  $C_v \geq 1$
2. Repetitive factor,  $C_r = 1.04$

### E. Special factors

1. Buckling stiffness factor,  $C_T$  (applied only to sawn lumber and to  $E_{min}$ )  $\geq 1$
2. Stress interaction factor,  $C_I$  (applied only to GLULAM and tapered section)  $\leq 1$
3. Shear reduction factor,  $C_{vr}$  (applied only to GLULAM and to  $F_v$  in some cases) = 0.72

\* When the volume factor  $C_v > 1$ , it is used in the calculation of beam stability factor, as discussed in Chapter 7.

**TABLE 6.7**  
**Applicability of Adjustment Factors for SCL**

Loading Condition	Loading Case	Factor						Special Factor		
		Time Effect	Wet Service	Temperature	Size (Volume)	Repetitive	Beam Stability	Column Stability	Bearing Area	
Bending	Load perpendicular to lamination	$\lambda$	$C_M$	$C_t$	$C_v^a$	$C_r$	$C_L^a$			
Tension		$\lambda$	$C_M$	$C_t$						
Compression	Load parallel to grain	$\lambda$	$C_M$	$C_t$				$C_F$		
	Load perpendicular to grain	$\lambda$	$C_M$	$C_t$					$C_b$	
Shear		$\lambda$	$C_M$	$C_t$						
Modulus of elasticity			$C_M$	$C_t$						
Modulus of elasticity for stability			$C_M$	$C_t$						

<sup>a</sup> For SCL, when  $C_v \leq 1$  the lesser of  $C_v$  and  $C_L$  is applied. When  $C_v > 1$ , both  $C_v$  and  $C_L$  are applied.

**PROBLEMS**

**Note:** In Problems 6.1 through 6.5, determine the adjusted reference design values and the strength capacities for the following members. In all cases, consider dry-service conditions, normal temperature range, and no-incision application. In practice, all loading combinations must be checked. However, in these problems only a single load condition should be considered for each member, as indicated in the problem.

- 6.1 Floor joists are 2 in.  $\times$  6 in. at 18 in. on center (OC) of Douglas Fir-Larch #2. They support dead and live loads.
- 6.2 Roof rafters are 2 in.  $\times$  8 in. at 24 in. OC of Southern Pine #2. The loads are dead load and roof live load.
- 6.3 Five floor beams are of 4 in.  $\times$  8 in. dimension lumber Hem Fir #1, spaced 5 ft. apart. The loads are dead and live loads.
- 6.4 Studs are 2 in.  $\times$  8 in. at 20 in. OC of Hem Fir #2. The loads are dead load, live load, and wind load.
- 6.5 The interior column is 5 in.  $\times$  5 in. of Douglas Fir-Larch #2 to support the dead and live loads.
- 6.6 Determine the unit dead and live loads (per square foot area) that can be resisted by a floor system consisting of 2 in.  $\times$  4 in. joists at 18 in. OC of Douglas Fir-Larch #1. The span is 12 ft. The dead and live loads are equal.
- 6.7 Determine the unit dead load on the roof. The roof beams are 4 in.  $\times$  10 in. of Hem Fir #1. The beams are located at 5 ft. OC, and the span is 20 ft. apart. They support the dead load and a snow load of 20 psf.
- 6.8 A 6 in.  $\times$  6 in. column of Douglas Fir-Larch #1 supports the dead load and live load on an area of 100 ft.<sup>2</sup> Determine the per-square-foot load if the unit dead load is one-half of the unit live load.
- 6.9 A floor system is acted upon by a dead load of 20 psf and a live load of 40 psf. Determine the size of the floor joists of Douglas Fir-Larch Structural lumber. They are located 18 in. OC and span 12 ft. Assume that beam stability factor is not a concern.
- 6.10 In Problem 6.9, determine the size of the floor joists when used in the flat position.
- 6.11 Determine the size of a column of Southern Pine #2 of dimension lumber that receives loads from an area of 20 ft.  $\times$  25 ft. The unit service loads are 20 psf dead load and 30 psf live load. Assume that the column stability factor is not a concern.
- 6.12 For Problem 6.11, design a column of Southern Pine #2 timber.
- 6.13 A GLULAM beam section is 6 $\frac{3}{4}$  in.  $\times$  37.5 in. from the Douglas Fir 24F-1.7E class. The loads combination comprises the dead load, snow load, and wind load. The bending is about the  $x$  axis. Determine the adjusted nominal reference design stresses and the strength capacities for bending, tension, shear, compression, modulus of elasticity, and modulus of stability ( $E_{min}$ ). The span is 30 ft.
- 6.14 Determine the wind load for Problem 6.13 if the unit dead load is 50 psf and the unit snow and wind loads are equal. The beams are 10 ft. apart.
- 6.15 The beam in Problem 6.13 is installed upside down. Determine the strength capacities.
- 6.16 The beam in Problem 6.13 is used flat with bending about the minor axis. Determine the design capacities.
- 6.17 A 5 $\frac{1}{8}$  in.  $\times$  28.5 in. 26F-1.9E Southern Pine GLULAM is used to span 35 ft. The beam has a radius of curvature of 10 ft. The load combination is the dead load and the snow load. Determine the adjusted nominal reference design stresses and the strength capacities for loading perpendicular to the laminations for the beam installed according to specifications.
- 6.18 The beam in Problem 6.17 is installed upside down. Determine the percentage reduction in strength capacities.

- 6.19** The beam in Problem 6.17 is loaded along the laminations, about the minor axis. Determine the percentage change in strength capacities.
- 6.20** A  $1\frac{3}{4}$  in.  $\times$   $7\frac{1}{4}$  in. size LVL of 1.9E class is used for roof rafters spanning 20 ft., located 24 in. OC. Determine the strength design capacities for the dead and snow load combinations. The size factor is given by  $(12/d)^{1/7.5}$ .
- 6.21** Two  $1\frac{3}{4}$  in.  $\times$  16 in. (two sections side by side) of Parallam of 2.0E class are used for a floor beam spanning 32 ft., spaced 8 ft. OC. The loading consists of dead and live loads. Determine the strength capacities for bending, tension, compression, and shear. The size factor is given by  $(12/d)^{1/7.5}$ .
- 6.22** Determine the unit loads (per square foot) on the beam in Problem 6.21 if the live load is one-and-a-half times the dead load.

---

# 7 Flexure and Axially Loaded Wood Structures

## INTRODUCTION

The conceptual design of wood members was presented in Chapter 6. The underlying assumption of design in that chapter was that an axial member was subjected to axial tensile stress or axial compression stress only and a flexure member to normal bending stress only. However, the compression force acting on a member tends to buckle a member out of the plane of loading, as shown in Figure 7.1. This buckling occurs in the columns and in the compression flange of the beams unless the compression flange is adequately braced. The beam and column stability factors  $C_L$  and  $C_P$ , respectively, mentioned in the “Reference Design Values for Sawn Lumber” section of Chapter 6, are applied to account for the effect of this lateral buckling.

This chapter presents the detailed designs of flexure members, axially loaded tensile and compression members, and the members subjected to the combined flexure and axial force made of sawn lumber, glued laminated timber (GLULAM), and laminated veneer lumber (LVL).

## DESIGN OF BEAMS

In most cases, for the design of a flexure member or beam, the bending capacity of the material is a critical factor. Accordingly, the basic criterion for the design of a wood beam is developed from a bending consideration.

In a member subjected to flexure, compression develops on one side of the section; under compression, lateral stability is an important factor. It could induce a buckling effect that will undermine the moment capacity of the member. An adjustment factor is applied in wood design when the buckling effect could prevail, as discussed subsequently.

A beam is initially designed for the bending capacity. It is checked for the shear capacity. It is also checked from the serviceability consideration of the limiting state of deflection. If the size is not found adequate for the shear capacity or the deflection limits, the design is revised.

The bearing strength of a wood member is considered at the beam supports or where loads from other members frame onto the beam. The bearing length (width) is designed on this basis.

## BENDING CRITERIA OF DESIGN

For the bending capacity of a member, as discussed before

$$M_u = F_{bn}' S \quad (7.1)$$

$M_u$  represents the design moment due to the factored combination of loads. The design moment for a uniformly distributed load,  $w_u$ , is given by  $M_u = w_u L^2 / 8$  and for a concentrated load,  $P_u$ , centered at mid-span,  $M_u = P_u L / 4$ . For other cases,  $M_u$  is ascertained from the analysis of structure. For standard loading cases,  $M_u$  is listed in Appendix A, Table A.3.

The span length,  $L$ , is taken as the distance from the center of one support to the center of the other support. However, when the provided (furnished) width of a support is more than what is



**FIGURE 7.1** Buckling due to compression.

required from the bearing consideration, it is permitted to take the span length to be the clear distance between the supports plus one-half of the required bearing width at each end.

$F'_{bn}$  is the adjusted load resistance factor design (LRFD) reference value for bending. To start with, the reference bending design value,  $F_b$ , for the appropriate species and grade is obtained. These values are listed in Appendices B.2 through B.4 for sawn lumber and Appendices B.7 through B.9 for GLULAM and LVL. Then the value is adjusted by multiplying the reference value by a string of factors. The applicable adjustment factors were given in Table 6.5 for sawn lumber, in Table 6.6 for GLULAM, and in Table 6.7 for structural composite lumber (SCL).

For sawn lumber, the adjusted reference bending design value is restated as

$$F'_{bn} = \phi F_b \lambda C_M C_t C_F C_r C_{fu} C_i C_L K_F \quad (7.2)$$

For GLULAM, the adjusted reference bending design value is restated as

$$F'_{bn} = \phi F_b \lambda C_M C_t C_c C_{fu} C_i (C_v \text{ or } C_L) K_F \quad (7.3)$$

For SCL, the adjusted reference bending design value is

$$F'_{bn} = \phi F_b \lambda C_M C_t C_r (C_v \text{ or/and } C_L) K_F \quad (7.4)$$

where

$F_b$  is tabular reference bending design value

$\phi$  is resistance factor for bending = 0.85

$\lambda$  is time factor (Table 6.2)

$C_M$  is wet-service factor

$C_t$  is temperature factor

$C_F$  is size factor

$C_r$  is repetitive member factor

$C_{fu}$  is flat use factor

$C_i$  is incision factor

$C_L$  is beam stability factor

$C_c$  is curvature factor

$C_v$  is volume factor

$C_I$  is stress interaction factor

$K_F$  is format conversion factor = 2.54

Using the assessed value of  $F'_{bn}$ , from Equations 7.2 through 7.4, based on the adjustment factors known initially, the required section modulus,  $S$ , is determined from Equation 7.1 and a trial section is selected having the section modulus  $S$  higher than the computed value. In the beginning, some



section-dependent factors such as  $C_F$ ,  $C_v$ , and  $C_L$  will not be known while the others such as  $\lambda$ ,  $K_F$ , and  $\phi$  will be known. The design is performed considering all possible load combinations along with the relevant time factor. If loads are of one type only, that is, all vertical or all horizontal, the highest value of the combined load divided by the relevant time factor determines which combination is critical for design.

Based on the trial section, all adjustment factors including  $C_L$  are then computed and the magnitude of  $F'_{bn}$  is reassessed. A revised  $S$  is obtained from Equation 7.1 and the trial section is modified, if necessary.

## BEAM STABILITY FACTOR, $C_L$

As stated earlier, the compression stress, besides causing an axial deformation, can cause a lateral deformation if the compression zone of the beam is not braced against the lateral movement. In the presence of the stable one-half tensile portion, the buckling in the plane of loading is prevented. However, the movement could take place sideways (laterally), as shown in Figure 7.2.

The bending design described in Chapter 6 had assumed that no buckling was present and adjustments were made for other factors only. The condition of no buckling is satisfied when the bracing requirements, as listed in Table 7.1, are met. In general, when the depth-to-breadth ratio is 2 or less, no lateral bracings are required. When the depth-to-breadth ratio is more than 2 but does not exceed 4, the ends of the beam should be held in position by one of these methods: full-depth solid blocking, bridging, hangers, nailing, or bolting to other framing members. The stricter requirements are stipulated to hold the compression edge in line for a depth-to-breadth ratio of higher than 4.

When the requirements of Table 7.1 are not met, the following beam stability factor has to be applied to account for the buckling effect:

$$C_L = \left( \frac{1 + \alpha}{1.9} \right) - \sqrt{\left( \frac{1 + \alpha}{1.9} \right)^2 - \left( \frac{\alpha}{0.95} \right)} \quad (7.5)$$

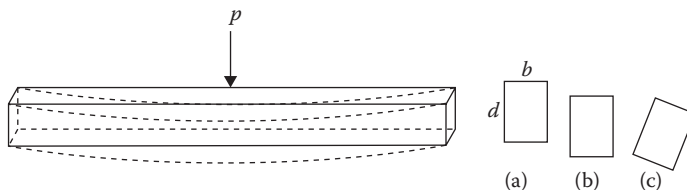
where

$$\alpha = \frac{F_{bEn}}{F'_{bn}^*} \quad (7.6)$$

where  $F'_{bn}^*$  is reference bending design value adjusted for all factors except  $C_v$ ,  $C_{fu}$ , and  $C_L$ .

For SCL, when  $C_v > 1$ ,  $C_v$  is also included in calculating  $F'_{bn}^*$ .  $F_{bEn}$  is the Euler-based LRFD critical buckling stress for bending.

$$F_{bEn} = \frac{1.2E'_{ymin(n)^*}}{R_B^2} \quad (7.7)$$



**FIGURE 7.2** Buckling of a bending member: (a) original position of the beam, (b) deflected position without lateral instability, and (c) compression edge buckled laterally.

\* Use  $y$  axis.

**TABLE 7.1**  
**Bracing Requirements for Lateral Stability**

Depth/Breadth Ratio <sup>a</sup>	Bracing Requirements
<b>Sawn Lumber</b>	
≤2	No lateral bracing required.
>2 but ≤4	The ends are to be held in position, as by full-depth solid blocking, bridging, hangers, nailing, or bolting to other framing members, or by other acceptable means.
>4 but ≤5	The compression edge is to be held in line for its entire length to prevent lateral displacement, as by sheathing or subflooring, and the ends at points of bearing are to be held in position to prevent rotation and/or lateral displacement.
>5 but ≤6	Bridging, full-depth solid blocking, or diagonal cross bracing is to be installed at intervals not exceeding 8 ft., the compression edge is to be held in line for its entire length to prevent lateral displacement, as by sheathing or subflooring, and the ends at points of bearing are to be held in position to prevent rotation and/or lateral displacement.
>6 but ≤7	Both edges of a member are to be held in line for their entire length, and the ends at points of bearing are to be held in position to prevent rotation and/or lateral displacement.
Combined bending and compression	The depth/breadth ratio may be as much as 5 if one edge is held firmly in line. If under all load conditions, the unbraced edge is in tension, the depth/breadth ratio may be as much as 6.
<b>Glued Laminated Timber</b>	
≤1	No lateral bracing required.
>1	The compression edge is supported throughout its length to prevent lateral displacement, and the ends at point of bearing are laterally supported to prevent rotation.

<sup>a</sup> Nominal dimensions.

where

$E'_{\min(n)}$  is adjusted nominal stability modulus of elasticity

$R_B$  is slenderness ratio for bending

$$R_B = \sqrt{\frac{L_e d}{b^2}} \leq 50 \quad (7.8)$$

where  $L_e$  is effective unbraced length, as discussed in the “Effective Unbraced Length” section.

When  $R_B$  exceeds 50 in Equation 7.7, the beam dimensions should be revised to limit the slenderness ratio to 50.

### EFFECTIVE UNBRACED LENGTH

The effective unbraced length is a function of several factors such as the type of span (simple, cantilever, continuous), the type of loading (uniform, variable, concentrated loads), the unbraced length,  $L_u$ , which is the distance between the points of lateral supports, and the size of the beam.

For a simple one span or cantilever beam, the following values can be conservatively used for the effective length:

$$\text{For } \frac{L_u}{d} < 7, \quad L_e = 2.06L_u \quad (7.9)$$

$$\text{For } 7 \leq \frac{L_u}{d} \leq 14.3, \quad L_e = 1.63L_u + 3d \quad (7.10)$$

$$\text{For } \frac{L_u}{d} > 14.3, \quad L_e = 1.84L_u \quad (7.11)$$

**Example 7.1**

A 5½ in. × 24 in. GLULAM beam is used for a roof system having a span of 32 ft., which is braced only at the ends. GLULAM consists of the Douglas Fir 24F-1.8E. Determine the beam stability factor. Use the dead and live conditions only.

**SOLUTION**

1. Reference design values

$$F_b = 2400 \text{ psi}$$

$$E = 1.8 \times 10^6 \text{ psi}$$

$$E_{y(\min)} = 0.83 \times 10^6 \text{ psi}$$

2. Adjusted design values

$$\begin{aligned} F_{bn}^* &= \phi F_b \lambda K_F \\ &= (0.85)(2400)(0.8)(2.54) = 4147 \text{ psi or } 4.15 \text{ ksi} \end{aligned}$$

$$\begin{aligned} E'_{\min(n)} &= \phi E_{y(\min)} K_F \\ &= (0.85)(0.83 \times 10^6)(1.76) = 1.24 \times 10^6 \text{ psi or } 1.24 \times 10^3 \text{ ksi} \end{aligned}$$

3. Effective unbraced length

$$\frac{L_u}{d} = \frac{32 \times 12}{24} = 16 > 14.3$$

From Equation 7.11

$$L_e = 1.84L_u = 1.84(32) = 58.88 \text{ ft. or } 701.28 \text{ in.}$$

4. From Equation 7.8

$$\begin{aligned} R_B &= \sqrt{\frac{L_e d}{b^2}} \\ &= \sqrt{\frac{(701.28)(24)}{(5.5)^2}} \\ &= 23.59 < 50 \quad \mathbf{OK} \end{aligned}$$

$$\begin{aligned} 5. F_{bEn} &= \frac{1.2E'_{\min(n)}}{R_B^2} \\ &= \frac{1.2(1.24 \times 10^3)}{(23.59)^2} = 2.7 \end{aligned}$$

$$6. \alpha = \frac{F_{bEn}}{F_{bn}^*} = \frac{2.7}{4.15} = 0.65$$

7. From Equation 7.5

$$C_L = \frac{1.65}{1.9} - \sqrt{\left(\frac{1.65}{1.9}\right)^2 - \left(\frac{0.65}{0.95}\right)} = 0.6$$

**SHEAR CRITERIA**

A transverse loading applied to a beam results in vertical shear stresses in any transverse (vertical) section of a beam. Because of the complimentary property of shear, an associated longitudinal shear stress acts along the longitudinal plane (horizontal face) of a beam element. In any mechanics of materials text, it can be seen that the longitudinal shear stress distribution across the cross section is given by

$$f_v = \frac{VQ}{Ib} \quad (7.12)$$

where

$f_v$  is shear stress at any plane across the cross section

$V$  is shear force along the beam at the location of the cross section

$Q$  is moment of the area above the plane where stress is desired to the top or bottom edge of the section. Moment is taken at neutral axis

$I$  is moment of inertia along the neutral axis

$b$  is width of the section

Equation 7.12 also applies for the transverse shear stress at any plane of the cross section as well because the transverse and the longitudinal shear stresses are complimentary, numerically equal, and opposite in sign.

For a rectangular cross section, which is usually the case with wood beams, the shear stress distribution by the above relation is parabolic with the following maximum value at the center:

$$f_{vmax} = F'_{vn} = \frac{3 V_u}{2 A} \quad (7.13)$$

In terms of  $V_u$ , the basic equation for shear design of the beam is

$$V_u = \frac{2}{3} F'_{vn} A \quad (7.14)$$

where

$V_u$  is maximum shear force due to factored load on beam

$F'_{vn}$  is adjusted reference shear design value

$A$  is area of the beam

The National Design Specification (NDS) permits that the maximum shear force,  $V_u$ , might be taken to be the shear force at a distance equal to the depth of the beam from the support. However,  $V_u$  is usually taken to be the maximum shear force from the diagram, which is at the support for a simple span.

For sawn lumber, the adjusted reference shear design value is

$$F'_{vn} = \phi F_v \lambda C_M C_t C_i K_F \quad (7.15)$$

For GLULAM, the adjusted reference shear design value is

$$F'_{vn} = \phi F_v \lambda C_M C_t C_{vr} K_F \quad (7.16)$$

For SCL, the adjusted reference shear design value is

$$F'_{vn} = \phi F_v \lambda C_M C_i K_F \quad (7.17)$$

where

$F_v$  is tabular reference shear design value

$\phi$  is resistance factor for shear = 0.75

$\lambda$  is time factor (see the "Time Effect Factor,  $\lambda$ " section in Chapter 6)

$C_M$  is wet-service factor

$C_t$  is temperature factor

$C_i$  is incision factor

$C_{vr}$  is shear reduction factor

$K_F$  is format conversion factor = 2.88

## DEFLECTION CRITERIA

It should be noted that deflection is a service requirement. It is accordingly computed using the service loads (not the factored loads).

The deflection in a beam comprises flexural deflection and shear deflection; the latter is normally a very small quantity. The reference design values for modulus of elasticity,  $E$ , as given in NDS 2012 with adjustments as shown in Equation 7.19, include a shear deflection component, which means that only the flexural deflection is to be considered in beam design.

However, where the shear deflection could be appreciable as on a short heavily loaded beam, it should be accounted for separately in addition to the flexural deflection. The shear deflection is computed by integrating the shear strain term  $V_{(x)}/GAb$  by expressing the shear force in terms of  $x$ . The form of the shear deflection is  $\delta = kWL/GA'$ , where  $k$  is a constant that depends on the loading condition,  $G$  is modulus of rigidity, and  $A'$  is the modified beam area. When the shear deflection is considered separately, a shear free value of modulus of elasticity should be used. For sawn lumber and GLULAM it is approximately 1.03 and 1.05 times, respectively, of the listed NDS reference design value.

The flexural deflection is a function of the type of loading, type of beam span, moment of inertia of the section, and modulus of elasticity. For a uniformly loaded simple span member, the maximum deflection at mid-span is

$$\delta = \frac{5wL^4}{384E'I} \quad (7.18)$$

where

$w$  is uniform combined service load per unit length

$L$  is span of beam

$E'$  is adjusted modulus of elasticity

$$E' = EC_M C_i C_t \quad (7.19)$$

$E$  is reference modulus of elasticity

$I$  is moment of inertia along neutral axis

However, depending on the loading condition, the theoretical derivation of the expression for deflection might be quite involved. For some commonly encountered load conditions, when the expression of the bending moment is substituted in the deflection expression, a generalized form of deflection can be expressed as follows:

$$\delta = \frac{ML^2}{CEI} \quad (7.20)$$

where

$w$  is service loads combination

$M$  is moment due to the service loads

The values of constant  $C$  are indicated in Table 7.2 for different load cases.


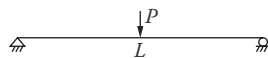
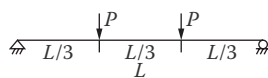
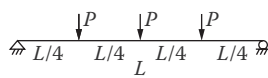

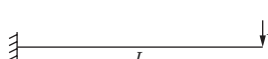
In a simplified form, the designed factored moment,  $M_u$  can be converted to the service moment dividing by a factor of 1.5 (i.e.,  $M = M_u/1.5$ ). The service live load moment,  $M_L$  is approximately 2/3 of the total moment  $M$  (i.e.,  $M_L = 2M_u/4.5$ ). The factor  $C$  from Table 7.2 can be used in Equation 7.20 to compute the expected deflection.

The actual (expected) maximum deflection should be less than or equal to the allowable deflections,  $\Delta$ . Often a check is made for live load alone as well as for the total load. Thus,

$$\text{Max. } \delta_L \leq \text{allow. } \quad L \quad (7.21)$$

$$\text{Max. } \delta_{TL} \leq \text{allow. } \quad TL \quad (7.22)$$

**TABLE 7.2**  
**Deflection Loading Constants**

Diagram of Load Condition	Constant C for Equation 7.20
	9.6
	12
	9.39
	10.13
	4
	3

**TABLE 7.3**  
**Recommended Deflection Criteria**

Classification	Live or Applied Load Only	Dead Load Plus Applied Load
Roof beams		
No ceiling	Span/180	Span/120
Without plaster ceiling	Span/240	Span/180
With plaster ceiling	Span/360	Span/240
Floor beams <sup>a</sup>	Span/360	Span/240
Highway bridge stringers	Span/300	
Railway bridge stringers	Span/300–Span/400	

Source: American Institute of Timber Association, *Timber Construction Manual*, 5th edn., John Wiley, New York, 2005.

<sup>a</sup> Additional limitations are used where increased floor stiffness or reduction of vibrations is desired.

The allowable deflections are given in Table 7.3

When the above criteria are not satisfied, a new beam size is determined using the allowable deflection as a guide and computing the desired moment of inertia on that basis.

**CREEP DEFLECTION**

In addition to the elastic deflection discussed above, beams deflect more with time. This is known as the *creep* or the time-dependent deflection. When this is foreseen as a problem, the member size designed on the basis of elastic or short-term deflection is increased to provide for extra stiffness.

The total long-term deflection is computed as

$$\delta_t = K_{cr} \delta_{LT} + \delta_{ST} \quad (7.23)$$

where

$\delta_t$  is total deflection

$K_{cr}$  is a creep factor, = 1.5 for lumber, GLULAM, SCL

$\delta_{LT}$  is elastic deflection due to dead load and a portion (if any) of live load representing the long-term design load

$\delta_{ST}$  is elastic deflection due to remaining design load representing short-term design load

### Example 7.2

Design roof rafters spanning 16 ft. and spaced 16 in. on center (OC). The plywood roof sheathing prevents local buckling. The dead load is 12 psf and the roof live load is 20 psf. Use Douglas Fir-Larch #1 wood.

### SOLUTION

#### A. Loads

1. Tributary area/ft. =  $\frac{16}{12} \times 1 = 1.333 \text{ ft.}^2/\text{ft.}$
2. Loads per feet  
 $w_D = 12 \times 1.333 = 16 \text{ lb/ft.}$   
 $w_L = 20 \times 1.333 = 26.66 \text{ lb/ft.}$
3. Loads combination  
 $w_u = 1.2w_D + 1.6w_L$   
 $= 1.2(16) + 1.6(26.66) = 61.86 \text{ lb/ft.}$
4. Maximum BM  
 $M_u = \frac{w_u L^2}{8} = \frac{(61.86)(16)^2}{8} = 1974.52 \text{ ft. lb or } 23.75 \text{ in. - k}$
5. Maximum shear  
 $V_u = \frac{w_u L}{2} = \frac{(61.86)(16)}{2} = 494.9 \text{ lb}$

#### B. Reference design values (Douglas Fir-Larch #1, 2 in. and wider)

1.  $F_b = 1000 \text{ psi}$
2.  $F_v = 180 \text{ psi}$
3.  $E = 1.7 \times 10^6 \text{ psi}$
4.  $E_{min} = 0.62 \times 10^6 \text{ psi}$

#### C. Preliminary design

1. Initially adjusted bending design value

$$F'_{bn} \text{ (estimated)} = \phi F_b \lambda C_r K_F$$

$$= (0.85)(1000)(0.8)(1.15)(2.54) = 1986$$

$$2. \quad S_{reqd} = \frac{M_u}{F'_{bn} \text{ (estimated)}} = \frac{(23.75 \times 1000)}{1986} = 11.96$$

3. Try 2 in.  $\times$  8 in.  $S = 13.14 \text{ in.}^3$   
 $A = 10.88 \text{ in.}^2$   
 $I = 47.63 \text{ in.}^4$

## D. Revised design

## 1. Adjusted reference design values

	Reference Design Values (psi)	$\phi$	$\lambda$	$C_F$	$C_r$	$K_F$	$F'_{(n)}$ (psi)
$F'_{bn}$ <sup>a</sup>	1000	0.85	0.8	1.2	1.15	2.54	2384
$F'_{vn}$	180	0.75	0.8	—	—	2.88	311
$E'$	$1.7 \times 10^6$	—	—	—	—	—	$1.7 \times 10^6$
$E'_{min(n)}$	$0.62 \times 10^6$	0.85	—	—	—	1.76	$0.93 \times 10^6$

<sup>a</sup> Without the  $C_L$  factor.

2. Beam stability factor  $C_L = 1.0$ 

## E. Check for bending strength

$$\begin{aligned} \text{Bending capacity} &= F'_{bn} S \\ &= \frac{(2384)(14.14)}{1000} = 31.33 > 23.75 \text{ in.} - \mathbf{k} \quad \mathbf{OK} \end{aligned}$$

## F. Check for shear strength

$$\text{Shear capacity} = F'_{vn} \left( \frac{2A}{3} \right) = 311 \left( \frac{2}{3} \times 10.88 \right) = 2255 \text{ lb} > 494.5 \text{ lb} \quad \mathbf{OK}$$

## G. Check for deflection

1. Deflection is checked for service load,  $w = 16 + 26.66 = 42.66 \text{ lb/ft.}$

$$2. \delta = \frac{5}{384} \frac{wL^4}{EI} = \frac{5}{384} \frac{(42.66)(16)^4(12)^3}{(1.7 \times 10^6)(47.63)} = 0.78 \text{ in.}$$

3. Allowable deflection (w/o plastered ceiling)

$$\Delta = \frac{L}{180} = \frac{16 \times 12}{180} = 1.07 \text{ in.} > 0.78 \text{ in.} \quad \mathbf{OK}$$

**Example 7.3**

A structural GLULAM is used as a beam to support a roof system. The tributary width of the beam is 16 ft. The beam span is 32 ft. The floor dead load is 15 psf and the live load is 40 psf. Use Douglas Fir GLULAM 24F-1.8E. The beam is braced only at the supports.

**SOLUTION**

## A. Loads

1. Tributary area/ft. =  $16 \times 1 = 16 \text{ ft.}^2/\text{ft.}$

2. Loads per foot

$$w_D = 15 \times 16 = 240 \text{ lb/ft.}$$

$$w_L = 40 \times 16 = 640 \text{ lb/ft.}$$

3. Design load,  $w_u = 1.2w_D + 1.6w_L$

$$= 1.2(240) + 1.6(640) = 1312 \text{ lb/ft. or } 1.31 \text{ k/ft.}$$

4. Design bending moment

$$M_u = \frac{w_u L^2}{8} = \frac{(1.31)(32)^2}{8} = 167.68 \text{ ft.} - \mathbf{k} \text{ or } 2012.16 \text{ in.} - \mathbf{k}$$

5. Design shear

$$V_u = \frac{w_u L}{2} = \frac{1.31(32)}{2} = 20.96 \text{ k}$$



## B. Reference design values

$$F_b = 2400 \text{ psi}$$

$$F_v = 265 \text{ psi}$$

$$E = 1.8 \times 10^6 \text{ psi}$$

$$E_{y(\min)} = 0.83 \times 10^6 \text{ psi}$$

## C. Preliminary design

1. Initially adjusted bending reference design value

$$F'_{bn} (\text{estimated}) = \phi F_b \lambda K_F \\ = (0.85)(2400)(0.8)(2.54) = 4145 \text{ psi or } 4.15 \text{ ksi}$$

2. 
$$S_{reqd} = \frac{2012.16}{4.15} = 484.86 \text{ in.}^3$$

Try  $5 \frac{1}{2} \text{ in.} \times 24 \text{ in.}$   $S = 528 \text{ in.}^3$

$$A = 132 \text{ in.}^2$$

$$I = 6336 \text{ in.}^4$$

## D. Revised adjusted design values

Type	Reference Design Values (psi)	$\phi$	$\lambda$	$K_F$	$F'_{0n}$ (psi)
$F'_{bn}*$	2400	0.85	0.8	2.54	4145
$F'_{vn}$	265	0.75	0.8	2.88	457.9
$E'$	$1.8 \times 10^6$	—	—	—	$1.8 \times 10^6$
$E'_{\min(n)}$	$0.83 \times 10^6$	0.85	—	1.76	$1.24 \times 10^6$

*Note:*  $F'_{bn}*$  is reference bending design value adjusted for all factors except  $C_v$ ,  $C_{fu}$ , and  $C_L$ .

E. Volume factor,  $C_v$ 

$$C_v = \left( \frac{5.125}{b} \right)^{1/10} \left( \frac{12}{d} \right)^{1/10} \left( \frac{21}{L} \right)^{1/10} \\ = \left( \frac{5.125}{5.5} \right)^{1/10} \left( \frac{12}{24} \right)^{1/10} \left( \frac{21}{32} \right)^{1/10} = 0.89$$

F. Beam stability factor,  $C_L$ From Example 7.1,  $C_L = 0.60$ Since  $C_L < C_v$ , use the  $C_L$  factor

## G. Bending capacity

1. 
$$F'_{bn} = (4145)(0.6) = 2487 \text{ psi or } 2.49 \text{ ksi}$$

2. Moment capacity =  $F'_{bn} S$

$$= 2.49(528)$$

$$= 1315 \text{ in.} \cdot \text{k} < 2012.16(M_u) \quad \mathbf{NG}$$

A revised section should be selected and steps E, F, and G should be repeated.

## H. Check for shear strength\*

$$\text{Shear capacity} = F'_{vn} \left( \frac{2A}{3} \right) = 457.9 \left( \frac{2}{3} \times 132 \right) = 40295 \text{ lb or } 40.3 \text{ k} > 20.29 \text{ k} \quad \mathbf{OK}$$

## I. Check for deflection

1. Deflection checked for service load  $w = 240 + 640 = 880 \text{ lb/ft.}$

2. 
$$\delta = \frac{5}{384} \frac{wL^4}{EI} = \frac{5}{384} \frac{(880)(32)^4(12)^3}{(1.8 \times 10^6)(6336)} = 1.82 \text{ in.}$$

\* Based on the original section.

3. Permissible deflection (w/o plastered ceiling)

$$= \frac{L}{180} = \frac{32 \times 12}{180} = 2.13 \text{ in.} > 1.82 \text{ in.} \quad \mathbf{OK}$$

## BEARING AT SUPPORTS

The bearing perpendicular to the grains occurs at the supports or wherever a load-bearing member rests onto the beam, as shown in Figure 7.3. The relation for bearing design is

$$P_u = F'_{C_{\perp n}} A \quad (7.24)$$

The adjusted compressive design value perpendicular to grain is obtained by multiplying the reference design value by the adjustment factors. Including these factors, Equation 7.19 becomes

For sawn lumber,

$$P_u = \phi F_{C_{\perp}} \lambda C_M C_t C_i C_b K_F A \quad (7.25)$$

For GLULAM and SCL,

$$P_u = \phi F_{C_{\perp}} \lambda C_M C_t C_b K_F A \quad (7.26)$$

where

$P_u$  is reaction at the bearing surface due to factored load on the beam

$F_{C_{\perp}}$  is reference compressive design value perpendicular to grain

$F'_{C_{\perp n}}$  is adjusted compressive design value perpendicular to grain

$\phi$  is resistance factor for compression = 0.9

$\lambda$  is time effect factor (see the "Time Effect Factor,  $\lambda$ " section in Chapter 6)

$C_M$  is wet-service factor

$C_t$  is temperature factor

$C_i$  is incision factor

$C_b$  is bearing area factor as discussed below

$K_F$  is format conversion factor for bearing =  $1.875/\phi$

$A$  is area of bearing surface

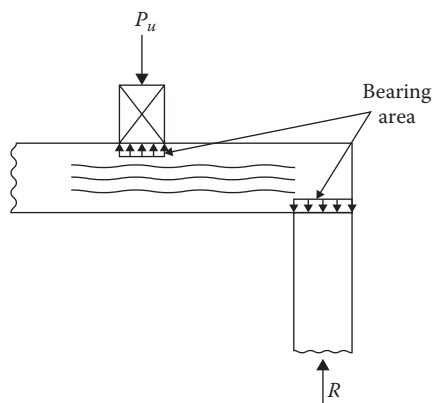


FIGURE 7.3 Bearing perpendicular to grain.

**BEARING AREA FACTOR,  $C_b$** 

The bearing area factor is applied only to a specific case when the bearing length  $l_b$  is less than 6 in. and also the distance from the end of the beam to the start of the contact area is larger than 3 in., as shown in Figure 7.4. The factor is not applied to the bearing surface at the end of a beam, which may be of any length, or where the bearing length is 6 in. or more at any other location than the end. This factor accounts for the additional wood fibers that could resist the bearing load. It increases the bearing length by 3/8 in. Thus,

$$C_b = \frac{l_b + 3/8}{l_b} \quad (7.27)$$

where  $l_b$ , the bearing length, is the contact length parallel to the grain.

**Example 7.4**

For Example 7.3, determine the bearing surface area at the beam supports.

**SOLUTION**

1. Reaction at the supports

$$R_u = \frac{w_u L}{2} = \frac{1.31(32)}{2} = 20.96 \text{ k}$$

2. Reference design value for compression perpendicular to grains,  $F_{C\perp n} = 650$  psi
3. Initially adjusted perpendicular compression reference design value

$$F'_{C\perp n} = \phi F_{C\perp} \lambda C_M C_t C_i K_F \\ = 0.9(650)(0.8)(1)(1)(1.67) = 782 \text{ psi or } 0.782 \text{ ksi}$$

4.  $A_{reqd} = \frac{R_u}{F'_{C\perp n}} = \frac{20.96}{0.782} = 26.8 \text{ in.}^2$

5. Initial bearing length

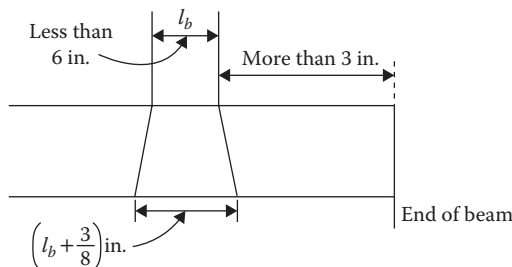
$$l_b = \frac{A}{b} = \frac{26.8}{5.5} = 4.87 \text{ in.}$$

6. Bearing area factor

$$C_b = \frac{l_b + 3/8}{l_b} = \frac{4.87 + 0.375}{4.87} = 1.08$$

7. Adjusted perpendicular compression design value

$$F'_{C\perp n} = 0.782 (1.08) = 0.84$$



**FIGURE 7.4** Bearing area factor.

$$8. A = \frac{R_u}{F'_{C \perp n}} = \frac{20.96}{0.84} = 24.95 \text{ in.}^2$$

$$9. \text{ Bearing length, } l_b = \frac{24.95}{5.5} = 4.54 \text{ in.}$$

## DESIGN OF AXIAL TENSION MEMBERS

Axially loaded wood members generally comprise studs, ties, diaphragms, shear walls, and trusses where loads directly frame into joints to pass through the member's longitudinal axis or with a very low eccentricity. These loads exert either tension or compression without any appreciable bending in members. For example, a truss has some members in compression and some in tension. The treatment of a tensile member is relatively straightforward because only the direct axial stress is exerted on the section. However, the design is typically governed by the net section at the connection because in a stretched condition, an opening separates out from the fastener.

The tensile capacity of a member is given by

$$T_u = F'_m A_n \quad (7.28)$$

Axial tension members in wood generally involve relatively small force for which a dimensional lumber section is used, which requires inclusion of a size factor.

Including the adjustment factors, the tensile capacity is represented as follows:

For sawn lumber,

$$T_u = \phi F_t \lambda C_M C_t C_F C_i K_F A_n \quad (7.29)$$

For GLULAM and SCL,

$$T_u = \phi F_t \lambda C_M C_t K_F A_n \quad (7.30)$$

where

$T_u$  is factored tensile load on member

$F_t$  is reference tension design value parallel to grain

$F'_m$  is adjusted tension design value parallel to grain

$\phi$  is resistance factor for tension = 0.8

$\lambda$  is time effect factor (see the "Time Effect Factor,  $\lambda$ " section in Chapter 6)

$C_M$  is wet-service factor

$C_t$  is temperature factor

$C_i$  is incision factor

$C_F$  is size factor for sawn dimension lumber only

$K_F$  is format conversion factor for tension = 2.70

$A_n$  is net cross-sectional area as follows:

$$A_n = A_g - \sum A_h \quad (7.31)$$

where

$A_g$  is gross cross-sectional area

$\sum A_h$  is sum of projected area of holes

In determining the net area of a nail or a screw connection, the projected area of the nail or screw is neglected. For a bolted connection, the projected area consists of rectangles given by

$$\sum A_h = nbh \quad (7.32)$$

where

$n$  is number of bolts in a row

$b$  is width (thickness) of the section

$h$  is diameter of the hole, usually  $d + 1/16$  in.

$d$  is diameter of the bolt

### Example 7.5

Determine the size of the bottom (tension) chord of the truss shown in Figure 7.5. The service loads acting on the horizontal projection of the roof are dead load = 20 psf and snow load = 30 psf. The trusses are 5 ft. on center. The connection is made by one bolt of 3/4 in. diameter in each row. Lumber is Douglas Fir-Larch #1.

### SOLUTION

#### A. Design loads

1. Factored unit loads =  $1.2D + 1.6S = 1.2(20) + 1.6(30) = 72$  psf
2. Tributary area,  $\text{ft.}^2/\text{ft.} = 5 \times 1 = 5$   $\text{ft.}^2/\text{ft.}$
3. Load/ $\text{ft.}$ ,  $w_u = 72(5) = 360$   $\text{lb}/\text{ft.}$
4. Load at joints

$$\text{Exterior} = 360 \left( \frac{7.5}{2} \right) = 1350 \text{ lb or } 1.35 \text{ k}$$

$$\text{Interior} = 360(7.5) = 2700 \text{ lb or } 2.7 \text{ k}$$

#### B. Analysis of truss

1. Reactions at A and E:  $A_y = 1.35 + 3 \left( \frac{2.7}{2} \right) = 5.4$  k
2. For members at joint A, taking moment at H,  
 $(5.4 - 1.35)7.5 - F_{AB}(5) = 0$   
 $F_{AB} = 6.075$  k  
 $F_{BC} = F_{AB} = 6.075$  k

#### C. Reference design value and the adjustment factors

1.  $F_t = 675$  psi
2.  $\lambda = 0.8$
3.  $\phi = 0.8$
4. Assume a size factor  $C_F = 1.5$ , which will be checked later
5.  $K_F = 2.70$
6.  $F'_{tn} = (0.8)(675)(0.8)(1.5)(2.7) = 1750$  psi or 1.75 ksi

#### D. Design

$$1. \quad A_{n \text{ reqd}} = \frac{P_u}{F'_{tn}} = \frac{6.075}{1.75} = 3.47 \text{ in.}^2$$

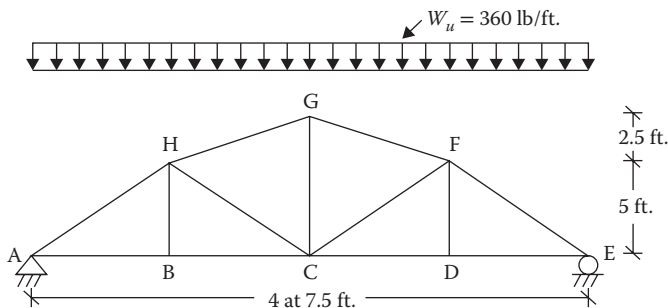


FIGURE 7.5 Roof truss of Example 7.5.

2. For one bolt in a row and an assumed 2-in.-wide section,

$$h = \frac{3}{4} + \frac{1}{16} = 0.813 \text{ in.}$$

$$\sum nbh = (1)(1.5)(0.813) = 1.22 \text{ in.}^2$$

3.  $A_g = A_n + A_h = 3.47 + 1.22 = 4.69 \text{ in.}^2$

Select a 2 in.  $\times$  4 in. section,  $A = 5.25 \text{ in.}^2$

4. Verify the size factor and revise the adjusted value if required

For 2 in.  $\times$  4 in.,  $C_f = 1.5$  the same as assumed

## DESIGN OF COLUMNS

The axial compression capacity of a member in terms of the nominal strength is

$$P_u = F'_{cn} A \quad (7.33)$$

In Equation 7.28,  $F'_{cn}$  is the adjusted LRFD reference design value for compression. To start with, the reference design compression value,  $F_c$ , for the appropriate species and grade is ascertained. These values are listed in Appendices B.2 through B.4 for sawn lumber and Appendices B.7 through B.9 for GLULAM and SCL. Then the adjusted value is obtained multiplying the reference value by a string of factors. The applicable adjustment factors for sawn lumber, GLULAM, and SCL are given in Tables 6.5 through 6.7 of Chapter 6, respectively.

For sawn lumber, the adjusted reference compression design value is

$$F'_{cn} = \phi F_c \lambda C_M C_t C_F C_i C_p K_F \quad (7.34)$$

For GLULAM and SCL, the adjusted reference compression design value is

$$F'_{cn} = \phi F_c \lambda C_M C_t C_p K_F \quad (7.35)$$

where

$F_c$  is tabular reference compression design value parallel to grain

$\phi$  is resistance factor for compression = 0.90

$\lambda$  is time factor (see the "Time Effect Factor,  $\lambda$ " section in Chapter 6)

$C_M$  is wet-service factor

$C_t$  is temperature factor

$C_F$  is size factor for dimension lumber only

$C_i$  is incision factor

$C_p$  is column stability factor, discussed below

$K_F$  is format conversion factor = 2.40

Depending on the relative size of a column, it might act as a *short column* when only the direct axial stress will be borne by the section or it might behave as a *long column* with a possibility of buckling and a corresponding reduction of the strength. This latter effect is considered by a column stability factor,  $C_p$ . As this factor can be ascertained only when the column size is known, the column design is a trial procedure.

The initial size of a column is decided using an estimated value of  $F'_{cn}$  by adjusting the reference design value,  $F_c$ , for whatever factors are initially known in Equation 7.34 or 7.35.

On the basis of the trial section,  $F'_{cn}$  is adjusted again from Equation 7.34 or 7.35 using all relevant modification factors and the revised section is determined from Equation 7.33.

### COLUMN STABILITY FACTOR, $C_p$

As stated, the column stability factor accounts for buckling. The slenderness ratio expressed as  $KL/r$  is a limiting criteria of buckling. For wood, the slenderness ratio is adopted in a simplified form as  $KL/d$ , where  $d$  is the least dimension of the column section. The factor,  $K$ , known as the *effective length factor*, depends on the end support conditions of the column. The column end conditions are identified in Figure 7.6 and the values of the effective length factors for these conditions are also indicated therein.

When a column is supported differently along the two axes, the slenderness ratio  $K$  is determined with respect to each axis and the highest ratio is used in design.

The slenderness ratio should not be greater than 50.

The expression for a column stability factor is similar to that of the beam stability factor, as follows:

$$C_p = \left( \frac{1 + \beta}{2c} \right) - \sqrt{\left( \frac{1 + \beta}{2c} \right)^2 - \left( \frac{\beta}{c} \right)} \tag{7.36}$$

where

$$\beta = \frac{F_{cEn}}{F'_{cn}} \tag{7.37}$$

Buckling mode	Translation fixed No sway Braced frame case			Translation free Sway Unbraced frame case		
	Both ends fixed	One fixed one hinged	Both ends hinged	Both ends fixed	One fixed one hinged	One fixed one free
End conditions						
Theoretical value	0.5	0.7	1.0	1.0	2.0	2.0
Recommended value	0.65	0.80	1.0	1.2	2.0	2.10
End condition code	   	Rotation fixed, translation fixed Rotation free, translation fixed Rotation fixed, translation free Rotation free, translation free				

FIGURE 7.6 Buckling length coefficients,  $K$ .

where

$F_{cn}^{*}$  is reference design value for compression parallel to grain adjusted by all factors except  $C_p$   
 $F_{cEn}$  is Euler critical buckling stress

$$F_{cEn} = \frac{0.822E'_{min(n)}}{(KL/d)^2} \quad (7.38)$$

Use the  $E'_{min(n)}$  value corresponding to the  $d$  dimension in the equation. Determine  $F_{cEn}$  for both axes and use the smaller value.

$$\frac{KL}{d} \leq 50 \quad (7.39)$$

where  $E'_{min(n)}$  is adjusted modulus of elasticity for buckling.

For sawn lumber,

$$E'_{min(n)} = \phi E_{min} C_M C_t C_i C_T K_F \quad (7.40)$$

For GLULAM and SCL,

$$E'_{min(n)} = \phi E_{min} C_M C_i K_F \quad (7.41)$$

where

$c$  is buckling–crushing interaction factor (0.8 for sawn lumber; 0.85 for round timber poles; 0.9 for GLULAM or SCL)

$\phi$  (=0.85) is resistance factor for stability modulus of elasticity

$C_T$  is buckling stiffness factor applicable to limited cases as explained in Chapter 6

$K_F$  (=1.76) is format conversion factor for stability modulus of elasticity

The column behavior is dictated by the interaction of the crushing and buckling modes of failure. When  $C_p$  is 1, the strength of a column is  $F_{cn}^{*}$  (the adjusted reference compressive design value without  $C_p$ ), and the mode of failure is by crushing. As the  $C_p$  reduces, that is, the slenderness ratio is effective, the column fails by the buckling mode.

### Example 7.6

Design a 12-ft.-long simply supported column. The axial loads are dead load = 1500 lb, live load = 1700 lb, and snow load = 2200 lb. Use Southern Pine #1.

### SOLUTION

#### A. Loads

The controlling combination is the highest ratio of the factored loads to the time effect factor.

$$1. \frac{1.4D}{\lambda} = \frac{1.4(1500)}{0.6} = 3500 \text{ lb}$$

$$2. \frac{1.2D + 1.6L + 0.5S}{\lambda} = \frac{1.2(1500) + 1.6(1700) + 0.5(2200)}{0.8} = 7025 \text{ lb}$$

$$3. \frac{1.2D + 1.6S + 0.5L}{\lambda} = \frac{1.2(1500) + 1.6(2200) + 0.5(1700)}{0.8} = 7713 \text{ lb} \leftarrow \text{Controls}$$

$$\text{So, } P_u = 1.2D + 1.6S + 0.5L = 6170 \text{ lb}$$



## B. Reference design values:

For 2- to 4-in.-wide section

$$F_c = 1850 \text{ psi}$$

$$E = 1.7 \times 10^6 \text{ psi}$$

$$E_{y \min} = 0.62 \times 10^6 \text{ psi}$$

## C. Preliminary design

$$F'_{cn} = \phi F_c \lambda K_F = (0.9)(1850)(0.8)(2.40) = 3196.8 \text{ psi}$$

$$A_{\text{reqd}} = \frac{6170}{3196.8} = 1.93 \text{ in.}^2$$

Try 2 in.  $\times$  4 in. section,  $A = 5.25 \text{ in.}^2$ 

## D. Adjusted design values

Type	Reference Design Values (psi)	$\phi$	$\lambda$	$C_F$	$K_F$	$F'_{0n}$ (psi)
Compression	1850	0.9	0.8	1	2.40	3196.8( $F'_{cn}$ )
$E$	$1.7 \times 10^6$	—	—	—	—	$1.7 \times 10^6$
$E_{\min}$	$0.62 \times 10^6$	0.85	—	—	1.76	$0.937 \times 10^6$

## E. Column stability factor

1. Both ends hinged,  $K = 1.0$ 

2. 
$$\frac{KL}{d} = \frac{1(12 \times 12)}{1.5} = 96 > 50 \quad \mathbf{NG}$$

3. Revise the section to 4 in.  $\times$  4 in.,  $A = 12.25 \text{ in.}^2$ 

4. 
$$\frac{KL}{d} = \frac{1(12 \times 12)}{3.5} = 41.14 < 50 \quad \mathbf{OK}$$

5. 
$$F_{cEn} = \frac{0.822(0.93 \times 10^6)}{(41.14)^2} = 451.68 \text{ psi}$$

6. 
$$\beta = \frac{F_{cEn}}{F'_{cn}} = \frac{451.68}{3196.8} = 0.14$$

7. 
$$C_p = \left( \frac{1+\beta}{2c} \right) - \sqrt{\left( \frac{1+\beta}{2c} \right)^2 - \left( \frac{\beta}{c} \right)}$$

$$= \frac{1.14}{1.6} - \sqrt{\left( \frac{1.14}{1.6} \right)^2 - \left( \frac{0.14}{0.8} \right)}$$

$$= 0.713 - \sqrt{(0.508) - (0.175)} = 0.136$$

## F. Compression capacity

1. 
$$P_u = F'_{cn} C_p A$$

$$= (3196.8)(0.136)(12.25) = 5325 \text{ lb} < 6170 \text{ lb} \quad \mathbf{NG}$$

Use section 4 in.  $\times$  6 in.,  $A = 19.25 \text{ in.}^2$ 

2.  $KL/d = 41.14$

3.  $F_{cEn} = 451.68 \text{ psi}$  for the smaller dimension

4.  $\beta = 0.14$

5.  $C_p = 0.136$

6. Capacity =  $(3196.8)(0.136)(19.25) = 8369 > 6170 \text{ lb} \quad \mathbf{OK}$

**DESIGN FOR COMBINED BENDING AND COMPRESSION**

The members stressed simultaneously in bending and compression are known as *beam-columns*. The effect of combined stresses is considered through an interaction equation. When bending occurs simultaneously with axial compression, a *second order effect* known as the  $P$ - $\Delta$  moment

takes place. This can be explained as follows. First consider only the transverse loading that causes a deflection,  $\Delta$ . Now, when an axial load  $P$  is applied, it causes an additional bending moment equal to  $P\Delta$ . In a simplified approach, this additional bending stress is not computed directly. Instead, it is accounted for indirectly by amplifying the bending stress component in the interaction equation. This approach is similar to the design of steel structures.

The amplification is defined as follows:

$$\text{Amplification factor} = \frac{1}{\left(1 - \frac{P_u}{F_{cEx(n)}A}\right)} \quad (7.42)$$

where  $F_{cEx(n)}$  is the Euler-based stress with respect to the  $x$  axis slenderness as follows:

$$F_{cEx(n)} = \frac{0.822E'_{x\min(n)}}{(KL/d)_x^2} \quad (7.43)$$

where

$E'_{x\min(n)}$  is given by Equation 7.40 or 7.41

$E_{x\min}$  is stability modulus of elasticity along the  $x$  axis

$(KL/d)_x$  is slenderness ratio along the  $x$  axis

As  $P\Delta$  increases, the amplification factor or the secondary bending stresses increases.

From Equation 7.42, the amplification factor increases with a larger value of  $P_u$ . The increase of  $\Delta$  is built into the reduction of the term  $F_{cEx(n)}$ .

In terms of the load and bending moment, the interaction formula is expressed as follows:

$$\left(\frac{P_u}{F'_{cn}A}\right)^2 + \frac{1}{\left(1 - \frac{P_u}{F_{cEx(n)}A}\right)} \left(\frac{M_u}{F'_{bn}S}\right) \leq 1 \quad (7.44)$$

where

$F'_{cn}$  is reference design value for compression parallel to grain adjusted for all factors (see Equations 7.34 and 7.35)

$F_{cEx(n)}$  (see Equation 7.43)

$F'_{bn}$  is reference bending design value adjusted for all factors (see Equations 7.2 through 7.4)

$P_u$  is factored axial load

$M_u$  is factored bending moment

$A$  is area of cross section

$S$  is section modulus along the major axis

It should be noted that while determining the column adjustment factor  $C_p$ ,  $F_{cEn}$  in Equation 7.38 is based on the maximum slenderness ratio (generally with respect to the  $y$  axis is used), whereas the  $F_{cEx(n)}$  (in Equation 7.43) is based on the  $x$  axis slenderness ratio.

Equation 7.44 should be evaluated for all the load combinations.

The design proceeds with a trial section that in the first iteration is checked by the interaction formula with the initial adjusted design values (without the column and beam stability factors) and without the amplification factor. This value should be only a fraction of 1, preferably not exceeding 0.5.

Then the final check is made with the fully adjusted design values including the column and beam stability factors together with the amplification factor.

**Example 7.7**

A 16-ft.-long column in a building is subjected to a total vertical dead load of 4 k, and a roof live load of 5 k. Additionally a wind force of 200 lb/ft. acts laterally on the column. Design the column of 2DF GLULAM.

**SOLUTION**

## A. Load combinations

## a. Vertical loads

1.  $1.4D = 1.4(4) = 5.6$  k
2.  $1.2D + 1.6L + 0.5L_r = 1.2(4) + 1.6(0) + 0.5(5) = 7.3$  k
3.  $1.2D + 1.6L_r + 0.5L = 1.2(4) + 1.6(5) + 0.5(0) = 12.8$  k

## b. Vertical and lateral loads

4.  $1.2D + 1.6L_r + 0.5W$  broken down into (4a) and (4b) as follows:
    - 4a.  $1.2D + 1.6L_r = 1.2(4) + 1.6(5) = 12.8$  k (vertical)
    - 4b.  $0.5W = 0.5(200) = 100$  lb/ft. (lateral)
  5.  $1.2D + 1.0W + 0.5L + 0.5L_r$  broken down into (5a) and (5b) as follows:
    - 5a.  $1.2D + 0.5L_r + 0.5L = 1.2(4) + 0.5(5) = 7.3$  k (vertical)
    - 5b.  $1.0W = 1(200) = 200$  lb/ft. (lateral)
- Either 4 (4a + 4b) or 5 (5a + 5b) could be critical. Both will be evaluated.

## B. Initially adjusted reference design values

Property	Reference Design Values (psi)	$\phi$	$\lambda$	$K_F$	$F'_{0n}$	
					(psi)	(ksi)
Bending	1,700	0.85	0.8	2.54	2,936	2.94
Compression	1,950	0.90	0.8	2.40	3,369.6	3.37
$E$	$1.6 \times 10^6$	—	—	—	$1.6 \times 10^6$	$1.6 \times 10^3$
$E_{x\min}$	830,000	0.85	—	1.76	12,420,000	$1.242 \times 10^3$
$E_{y\min}$	830,000	0.85	—	1.76	12,420,000	$1.242 \times 10^3$

## I. Design Load case 4:

## C. Design loads

$$P_u = 12.8 \text{ k}$$

$$M_u = \frac{w_d L^2}{8} = \frac{100(16)^2}{8} = 3200 \text{ ft.-lb } 38.4 \text{ in.-k}$$

## D. Preliminary design

1. Try a  $5\frac{1}{8}$  in.  $\times$   $7\frac{1}{2}$  in. section,  $S_x = 48.05$  in.<sup>3</sup>  $A = 38.44$  in.<sup>2</sup>
2. Equation 7.37 with the initial design values but without the amplification factor

$$\left[ \frac{12.8}{3.37(38.44)} \right]^2 + \left[ \frac{38.4}{2.94(48.05)} \right]^2 = 0.27 \text{ a small fraction of 1 } \text{ OK}$$

E. Column stability factor,  $C_p$ 

1. Hinged ends,  $K = 1$
2.  $(KL/d)_y = \frac{(1)(16 \times 12)}{5.125} = 37.46 < 50$  OK
3.  $F_{cEn} = \frac{0.822(1.242 \times 10^3)}{(37.46)^2} = 0.728$
4.  $\beta = \frac{F_{cEn}}{F'_{cn}} = \frac{0.728}{3.37} = 0.216$

5.  $c = 0.9$  for GLULAM

$$6. C_p = \left[ \frac{1+0.216}{(2)(0.9)} \right] - \sqrt{\left( \frac{1+0.216}{2(0.9)} \right)^2 - \left( \frac{0.216}{0.9} \right)} = 0.21$$

7.  $F'_{cn} = 3.37(0.21) = 0.71$  ksi

F. Volume factor,  $C_v$

$$C_v = \left( \frac{5.125}{b} \right)^{1/10} \left( \frac{12}{d} \right)^{1/10} \left( \frac{21}{L} \right)^{1/10} = \left( \frac{5.125}{5.125} \right)^{1/10} \left( \frac{12}{7.5} \right)^{1/10} \left( \frac{21}{16} \right)^{1/10} = 1.07, \text{ use } 1.0.$$

G. Beam stability factor

1.  $\frac{L_u}{d} = \frac{16(12)}{7.5} = 25.6 > 14.3$

$$L_e = 1.84L_u = 1.84(16 \times 12) = 353.28 \text{ in.}$$

2.  $R_B = \sqrt{\frac{L_e d}{b^2}} = \sqrt{\frac{(353.28)(7.5)}{(5.125)^2}} = 10.04$

3.  $F_{bEn} = \frac{1.2(1.242 \times 10^3)}{(10.04)^2} = 14.82$

4.  $\alpha = \frac{F_{bEn}}{F'_{bn*}} = \frac{14.82}{2.94} = 5.04$

5.  $C_L = \left( \frac{1+5.04}{1.9} \right) - \sqrt{\left( \frac{1+5.04}{1.9} \right)^2 - \left( \frac{5.04}{0.95} \right)} = 0.99$

6.  $F'_{bn} = (2.94)(0.99) = 2.91$  ksi

H. Amplification factor

1. Based on the  $x$  axis,  $(KL/d)_x = \frac{1(16 \times 12)}{7.5} = 25.6$

2.  $F_{cEx(n)} = \frac{0.822E_{x\min(n)}}{(KL/d)^2}$   
 $= \frac{0.822(1.242 \times 10^3)}{(25.6)^2} = 1.56$

3. Amplification factor  $= \frac{1}{(1 - (P_u/F_{cEx(n)})A)}$   
 $= \frac{1}{1 - (12.8/(1.56)(38.44))} = \frac{1}{0.787} = 1.27$

I. Interaction equation, Equation 7.36

$$\left[ \frac{12.8}{(0.71)(38.44)} \right]^2 + \left[ \frac{1.27(38.4)}{(2.91)(48.05)} \right] = 0.22 + 0.35 = 0.57 < 1 \quad \mathbf{OK}$$

II. Design load case 5:

J. Design loads

$$P_u = 7.3 \text{ k}$$

$$M_u = \frac{w_u L^2}{8} = \frac{200(16)^2}{8} = 6400 \text{ ft.-lb or } 76.8 \text{ in.-k}$$

- K. Column stability factor,  $C_p = 0.21$  and  $F'_{cn} = 0.71$  ksi from step E  
 L. Beam stability factor,  $C_L = 0.99$  and  $F'_{bn} = 2.91$  ksi from step G  
 M. Amplification factor

$$= \frac{1}{(1 - (P_u / F_{cEx(n)} A))}$$

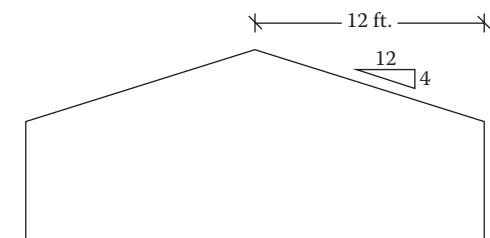
$$= \frac{1}{[1 - (7.3 / (1.56)(38.44))]} = \frac{1}{0.878} = 1.14$$

- L. Interaction equation, Equation 7.36

$$\left[ \frac{7.3}{(0.71)(38.44)} \right]^2 + \left[ \frac{1.14(76.8)}{(2.91)(48.05)} \right] = 0.07 + 0.626 = 0.7 < 1 \quad \text{OK}$$

## PROBLEMS

- 7.1** Design the roof rafters with the following information: check for shear and deflection.  
 1. Span: 10 ft.  
 2. Spacing: 16 in. on center (OC)  
 3. Species: Southern Pine #1  
 4. Dead load = 15 psf  
 5. Roof live load = 20 psf  
 6. Roof sheathing provides the full lateral support
- 7.2** Design the beam in Problem 7.1 except that the beam is supported only at the ends.
- 7.3** Design the roof rafters in Figure P7.1 with the following information:  
 1. Spacing 24 in. on center  
 2. Species: Douglas Fir-Larch #1  
 3. Dead load: 15 psf  
 4. Snow load: 40 psf  
 5. Wind load (vertical): 18 psf  
 6. Unbraced length: support at ends only
- 7.4** Design the floor beam in Figure P7.2 for the following conditions:  
 1. Span,  $L = 12$  ft.  
 2.  $P_D = 500$  lb (service)  
 3.  $P_L = 1000$  lb (service)  
 4. Unbraced length: one-half of the span  
 5. Species: Hem Fir #1
- 7.5** Design the beam in Problem 7.4 for the unbraced length equal to the span.



**FIGURE P7.1** Roof rafters for Problem 7.3.

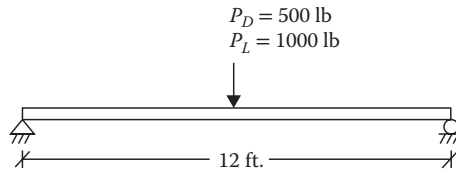


FIGURE P7.2 Floor beam for Problem 7.4.

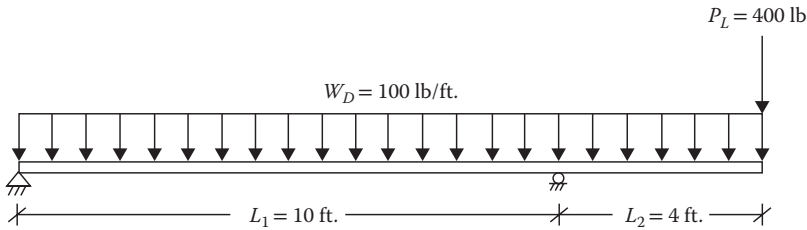


FIGURE P7.3 Floor beam for Problem 7.6.

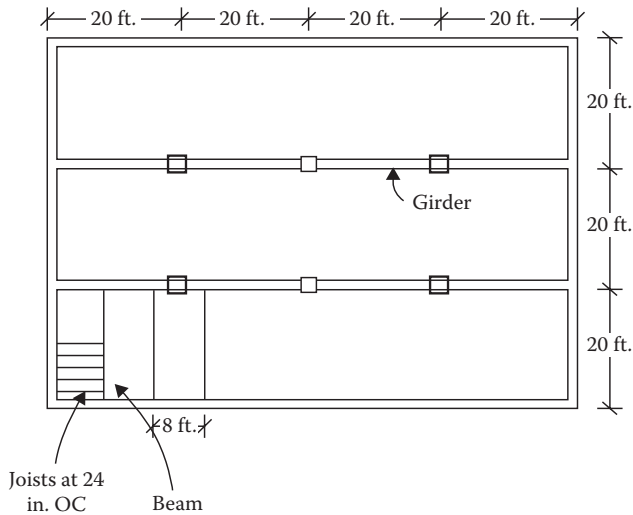
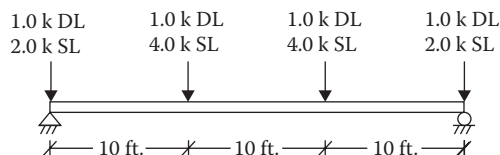


FIGURE P7.4 Floor framing plan for Problem 7.7.

7.6 Design the floor beam in Figure P7.3 with the following information:

1.  $w_D = 100$  lb/ft. (service)
2.  $P_L = 400$  lb (service)
3. Species: Douglas Fir-Larch Select Structural
4. Unbraced length: at the supports
5. The beam section should not be more than 10 in. deep.

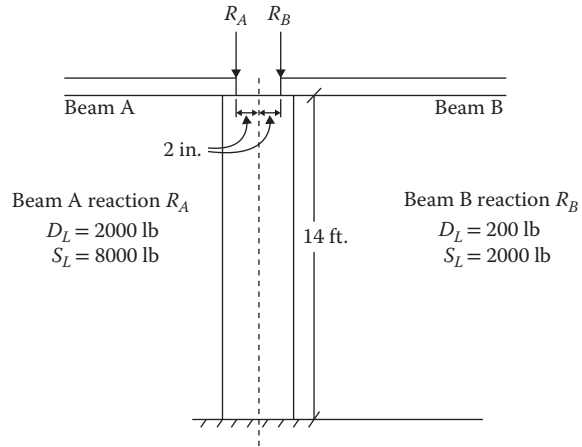
- 7.7** The floor framing plan of a building is shown in Figure P7.4. Dead loads are as follows:  
 Floor = 12 psf  
 Joists = 7 psf  
 Beams = 9 psf  
 Girders = 10 psf  
 Live load = 40 psf  
 Design the beams of Southern Pine select structural timber. The beam is supported only at the ends. The beam should not have more than 12 in. depth.
- 7.8** Design girders for Problem 7.7 of 24F-1.8E Southern Pine GLULAM of  $6\frac{3}{4}$  in. width having a lateral bracing at the supports only.
- 7.9** A Douglas Fir structural GLULAM of 24F-1.8E is used to support a floor system. The tributary width of the beam is 12 ft. and the span is 40 ft. The dead and live loads are 15 psf and 40 psf, respectively. Design a beam of  $10\frac{3}{4}$  width, braced only at the supports.
- 7.10** To the beam shown in Figure P7.5 the loads are applied by purlins spaced at 10 ft. on center. The beam has lateral supports at the ends and at the locations where the purlins frame onto the beam. Design the beam of 24F-1.8E Douglas Fir GLULAM. Use  $8\frac{3}{4}$ -wide section.
- 7.11** Design Problem 7.10. The beam is used flat with bending along the minor axis. Use  $10\frac{3}{4}$ -wide section.
- 7.12** Design the bearing plate for the supports from Problem 7.4.
- 7.13** Design the bearing plate for the supports from Problem 7.9.
- 7.14** Determine the length of the bearing plate placed under the interior loads of the beam from Problem 7.10.
- 7.15** Roof trusses, spanning 24 ft. at 4 ft. on center, support a dead load of 16 psf and a snow load of 50 psf only. The lumber is Hem Fir #1. The truss members are connected by a single row of  $\frac{3}{4}$ -in. bolts. Design the bottom chord. By truss analysis, the tensile force due to the service loads in the bottom chord members is 5.8 k. Assume the dry wood and normal temperature conditions.  
 [Hint: Divide the force in the chord between dead and snow loads in the above ratio of unit loads for factored load determination.]
- 7.16** A Warren-type truss supports only dead load. The lumber is Douglas Fir-Larch #2. The end connection consists of two rows of  $\frac{1}{2}$ -in. bolts. Determine the size of the tensile member. By truss analysis, the maximum force due to service load in the bottom chord is 5.56 k tension. Assume dry wood and normal temperature conditions.
- 7.17** Design a simply supported 10-ft.-long column using Douglas Fir-Larch #1. The loads comprise 10 k of dead load and 10 k of roof live load.
- 7.18** Design a 12-ft.-long simply supported column of Southern Pine #2. The axial loads are dead load = 1000 lb, live load = 2000 lb, and snow load = 2200 lb.
- 7.19** Design the column from Problem 7.18. A full support is provided by the sheathing about the smaller dimension.



**FIGURE P7.5** Load on beam by purlins for Problem 7.10.

- 7.20** What is the largest axial load that can be applied to a 4 in.  $\times$  6 in. #1 Hem Fir Column? The column is 15 ft. long, fixed at the both ends.
- 7.21** A 6 in.  $\times$  8 in. column carries dead and snow loads of equal magnitude. The lumber is Douglas Fir-Larch #1. If the unbraced length of the column, which is fixed at one end and hinged at the other end, is 9 ft., what is the load capacity of the column?
- 7.22** Determine the axial compression capacity of a 20-ft.-long GLULAM 6 $\frac{3}{4}$  in.  $\times$  11 in. column, hinged at both ends, of SPN1D14 Southern Pine of more than four lamination.
- 7.23** Determine the capacity column from Problem 7.22. It is braced at the center in the weaker direction.
- 7.24** A GLULAM column of 24F-1.8E Douglas Fir carries a dead load of 20 k and a roof live load of 40 k. The column has a simply supported length of 20 ft. Design an 8 $\frac{3}{4}$  in.-wide column.
- 7.25** The column in Problem 7.24 is braced along the weaker axis at 8 ft. from the top. Design a 6 $\frac{3}{4}$  in.-wide column.
- 7.26** A 2 in.  $\times$  6 in. exterior stud wall is 12 ft. tall. The studs are 16 in. on center. The studs carry the following vertical loads per foot horizontal distance of the wall:  
 Dead = 400 lb/ft.  
 Live = 1000 lb/ft.  
 Snow = 1500 lb/ft.  
 The sheathing provides the lateral support in the weaker direction. The lumber is Douglas Fir-Larch #1. Check the studs. Assume a simple end support condition and that the loads on studs act axially.
- 7.27** The first floor (10 ft. high) bearing wall of a building consists of 2 in.  $\times$  6 in. studs at 16 in. on center. The following roof loads are applied: roof dead load = 10 psf, roof live load = 20 psf, wall dead load = 5 psf, floor dead load = 7 psf, live load = 40 psf, lateral wind load = 25 psf. The tributary width of the roof framing to the bearing wall is 8 ft. The sheathing provides a lateral support to studs in the weaker direction. Check whether the wall studs made of Douglas Fir-Larch #2 are adequate.
- 7.28** A beam column is subjected to an axial dead load of 1 k, a snow load of 0.8 k, and a lateral wind load of 160 lb/ft. The column height is 10 ft. Design a beam-column of section 4  $\times$  \_\_\_\_ of Southern Pine #1.
- 7.29** A tall 20-ft.-long building column supports a dead load of 4 k and a live load of 5 k along with a lateral wind load of 240 lb/ft. Design a beam-column of 5 $\frac{1}{8}$  in.  $\times$  \_\_\_\_ section made of 2DFL2 GLULAM, more than four lamination.
- 7.30** A vertical 4 in.  $\times$  12 in. Southern Pine dense #1, 12-ft.-long member is embedded at the base to provide the fixidity. The other end is free to sway without rotation along the weaker axis and is hinged along the strong axis. The bracing about the weak axis is provided at every 4 ft. by wall girts and only at the ends about the strong axis. The dead load of 1000 lb and the roof live load of 4000 lb act axially. A uniform wind load of 240 lb/ft. acts along the strong axis. The sheathing provides a continuous lateral support to the compression side. Check the member for adequacy.  
 [Hint: Consider that the member is fixed at one end and has a spring support at the other end. For such a case, take the design end bending moment to be 70% of the maximum bending moment on the column acting like a cantilever.]
- 7.31** Solve Problem 7.30 when no lateral support to the compression side is provided. If a 4 in.  $\times$  12 in. section is not adequate, select a new section of a maximum 12 in. depth.
- 7.32** Choose a 5-in.-wide Southern Pine SPN1D14 GLULAM column supporting two beams, as shown in Figure P7.6. The beam reactions cause bending about the major axis only. The bottom is fixed and the top is hinged.





**FIGURE P7.6** Column supporting two beams for Problem 7.32.



---

# 8 Wood Connections

## TYPES OF CONNECTIONS AND FASTENERS

Broadly there are two types of wood connections: (1) the mechanical connections that attach members with some kind of fasteners and (2) the adhesive connections that bind members chemically together under controlled environmental conditions such as that seen in glued laminated timber (GLULAM). The mechanical connections, with the exception of moment splices, are not expected to transfer any moment from one element to another. The mechanical connections are classified according to the direction of load on the connector. Shear connections or lateral load connections have the load or the load component applied perpendicular to the length of the fastener. The withdrawal connections have the tensile load applied along (parallel to) the length of the fastener. When the load along the fastener length is in compression, a washer or a plate of sufficient size is provided so that the compressive strength of the wood perpendicular to the grain is not exceeded.

The mechanical type of connectors can be grouped as follows:

1. Dowel-type connectors
2. Split ring and shear plate connectors
3. Timber rivets
4. Pre-engineered metal connectors

Dowel-type connectors comprising nails, staples and spikes, bolts, lag bolts, and lag screws are the common type of fasteners that are discussed in this chapter. The post-frame ring shank nails that were the part of earlier specifications but were not included in the National Design Specification (NDS) 2005 have been reintroduced in 2012 specifications. The split ring and shear plate connectors fit into precut grooves and are used in shear-type connections to provide additional bearing area for added load capacity. Timber rivets or GLULAM rivets are nail-like fasteners of hardened steel (minimum strength of 145 ksi) with a countersunk head and rectangular-shaped cross section; they have no similarity to steel rivets. These are primarily used in GLULAM members for large loads.

Pre-engineered metal connectors comprise joist hangers, straps, ties, and anchors. These are used as accessories along with dowel-type fasteners. They make connections simpler and easier to design and in certain cases, such as earthquakes and high winds, are an essential requirement. The design strength values for specific connectors are available from the manufacturers.

## DOWEL-TYPE FASTENERS (NAILS, SCREWS, BOLTS, PINS)

The basic design equation for dowel-type fasteners is

$$R_z \text{ or } R_w \leq NZ'_n \quad (8.1)$$

where

$R_z$  is factored lateral design force on a shear-type connector

$R_w$  is factored axial design force on a withdrawal-type connector

$N$  is number of fasteners

$Z'_n$  is adjusted reference design value of a fastener given as

$$Z'_n = \text{reference design value } (Z) \times \text{adjustment factors} \tag{8.2}$$

The reference design value,  $Z$ , refers to the basic load capacity of a fastener. The shear-type connections rely on the bearing strength of wood against the metal fastener or the bending yield strength of the fastener (not the shear rupture of the fastener as in steel design). The withdrawal-type connections rely on the frictional or interfacial resistance to the transfer of loads. Until the 1980s, the capacities of fasteners were obtained from the empirical formulas based on field and laboratory tests. However, in the subsequent approach, the yield mechanism is considered from the principles of engineering mechanics. The yield-related approach is limited to the shear-type or laterally loaded connections. The withdrawal-type connections are still designed from the empirical formulas.

### YIELD LIMIT THEORY FOR LATERALLY LOADED FASTENERS

The yield limit theory considers the various modes (limits) by which a connection can yield under a lateral load. The capacity is computed for each mode of yielding. Then the reference value is taken as the smallest of these capacities.

In yield limit theory, the primary factors that contribute to the reference design value comprise the following:

1. Fastener diameter,  $D$
2. Bearing length,  $l$
3. Dowel-bearing strength of wood,  $F_{ew}$ , controlled by the (1) specific gravity of wood; (2) angle of application of load to the wood grain,  $\theta$ ; and (3) relative size of the fastener
4. Bearing strength of metal side plates,  $F_{ep}$
5. Bending yield strength,  $F_{yb}$

A subscript  $m$  or  $s$  is added to the above factors to indicate whether they apply to the main member or the side member. For example,  $l_m$  and  $l_s$  refer to bearing lengths of the main member and side member, respectively. For bolted connections, the bearing length  $l$  and member thickness are identical, as shown in Figure 8.1.

For nail, screw, or lag bolt connections, the bearing length of the main member,  $l_m$ , is less than the main member thickness, as shown in Figure 8.2.

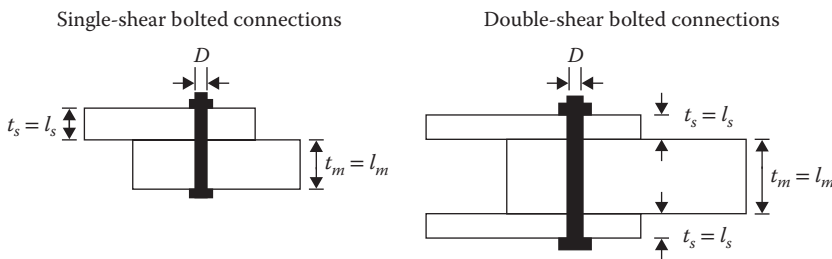


FIGURE 8.1 Bearing length of bolted connection.

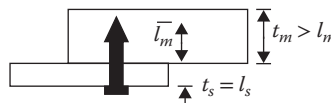


FIGURE 8.2 Bearing length of nail or screw connection.

Depending on the mode of yielding, one of the strength terms corresponding to items 3, 4, or 5 above or their combinations are the controlling factor(s) for the capacity of the fastener. For example, in the bearing-dominated yield of the wood fibers in contact with the fastener, the term  $F_{ew}$  for wood will be a controlling factor; for a metal side member used in a connection, the bearing strength of metal plate  $F_{ep}$  will control.

For a fastener yielding in bending with the localized crushing of the wood fibers, both  $F_{yb}$  and  $F_{ew}$  will be the relevant factors. The various yield modes are described in the “Yield Mechanisms and Yield Limit Equations” section.

1. The *dowel-bearing strength of wood*, also known as the *embedded strength*,  $F_{ew}$  (item 3 above), is the crushing strength of the wood member. Its value depends on the specific gravity of wood. For large-diameter fasteners ( $\geq 1/4$  in.), the bearing strength also depends on the angle of load to grains of wood. The NDS provides the values of specific gravity,  $G$ , for various species and their combinations and also includes the formulas and tables for the dowel-bearing strength,  $F_{ew}$ , for the two cases of loading—the load acting parallel to the grains and the load applied perpendicular to the grains.
2. The *bearing strength of steel members* (item 4 above) is based on the ultimate tensile strength of steel. For hot-rolled steel members (usually of thickness  $\geq 1/4$  in.),  $F_{ep} = 1.5 F_u$ , and for cold-formed steel members (usually  $< 1/4$  in.),  $F_{ep} = 1.375 F_u$ .
3. The *fastener bending yield strength*,  $F_{yb}$  (item 5 above), has been listed by the NDS for various types and diameters of fasteners. These values can be used in the absence of the manufacturer’s data.

## YIELD MECHANISMS AND YIELD LIMIT EQUATIONS

Dowel-type fasteners have the following four possible modes of yielding:

Mode I: Bearing yield of wood fibers when stress distribution is uniform over the entire thickness of the member.

In this case, due to the high lateral loading, the dowel-bearing stress of a wood member uniformly exceeds the strength of wood. This mode is classified as  $I_m$  if the bearing strength is exceeded in the main member and as  $I_s$  if the side member is overstressed, as shown in Figure 8.3.

Mode II: Bearing yield of wood by crushing due to maximum stress near the outer fibers.

The bearing strength of wood is exceeded in this case also. However, the bearing stress is not uniform. In this mode, the fastener remains straight but undergoes a twist that causes flexure-like nonuniform distribution of stress with the maximum stress at the outer fibers. The wood fibers are accordingly crushed at the outside face of both members, as shown in Figure 8.4.

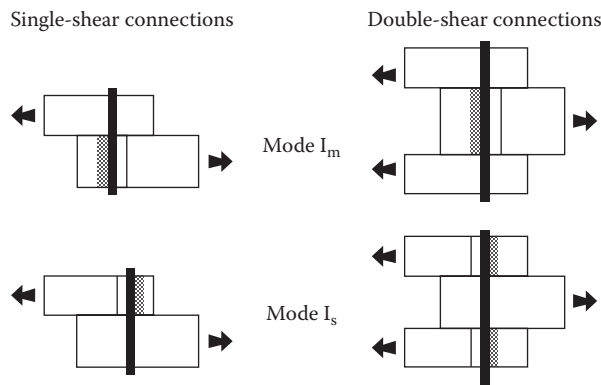


FIGURE 8.3 Mode I yielding. (Courtesy of American Forest & Paper Association, Washington, DC.)

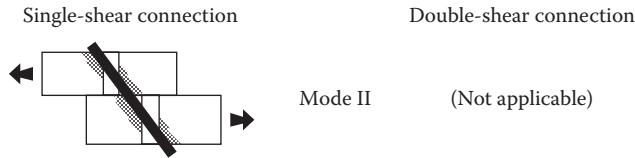


FIGURE 8.4 Mode II yielding. (Courtesy of American Forest & Paper Association, Washington, DC.)

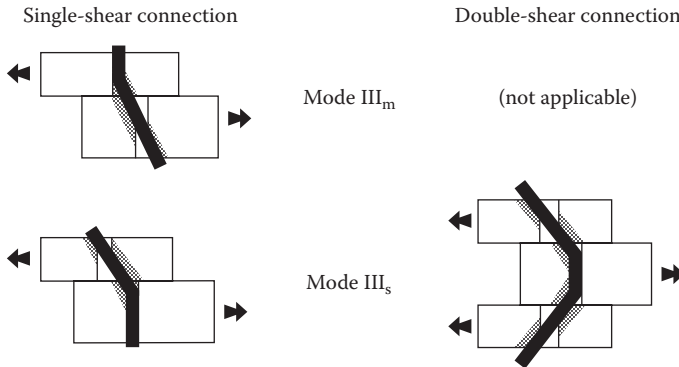


FIGURE 8.5 Mode III yielding. (Courtesy of American Forest & Paper Association, Washington, DC.)

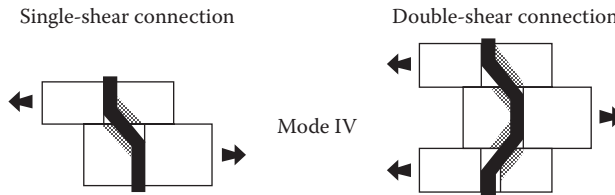


FIGURE 8.6 Mode IV yielding. (Courtesy of American Forest & Paper Association, Washington, DC.)

Mode II yield occurs simultaneously in the main and side members. It is not applicable to a double-shear connection because of symmetry by the two side plates.

Mode III: Fastener bends at one point within a member and wood fibers in contact with the fastener yield in bearing.

This is classified as III<sub>m</sub> when fastener bending occurs and the wood bearing strength is exceeded in the main member. Likewise, III<sub>s</sub> indicates the bending and crushing of wood fibers in the side member, as shown in Figure 8.5.

Mode III<sub>m</sub> is not applicable to a double-shear connection because of symmetry by the two side plates.

Mode IV: Fastener bends at two points in each shear plane and wood fibers yield in bearing near the shear plane(s).

Mode IV occurs simultaneously in the main and side members in a single shear, as shown in Figure 8.6. However, in a double shear, this can occur in each plane, hence yielding can occur separately in the main member and the side member.

To summarize, in a single-shear connection, there are six modes of failures comprising I<sub>m</sub>, I<sub>s</sub>, II, III<sub>m</sub>, III<sub>s</sub>, and IV. Correspondingly, there are six yield limit equations derived for the single-shear connections. For a double-shear connection, there are four modes of failures comprising I<sub>m</sub>, I<sub>s</sub>, IV<sub>m</sub>, and IV<sub>s</sub>. There are four corresponding yield limit equations for the double-shear connections.

## REFERENCE DESIGN VALUES FOR LATERAL LOADS (SHEAR CONNECTIONS)

For a given joint configuration, depending upon the single or the double-shear connection, six or four yield limit equations are evaluated and the smallest value obtained from these equations is used as a reference design value,  $Z$ .

Instead of using the yield limit equations, the NDS provides the tables for the reference design values that evaluate all relevant equations and adopts the smallest values for various fastener properties and specific gravity of species. The selected reference design values for the lateral loading are included in Appendix B, Tables B.10, B.12, B.14, B.16, and B.17 for different types of fasteners.

As stated above under the dowel-bearing strength of wood for fasteners of 1/4 in. or larger, the angle of loading with respect to the wood grains also affects the reference design values. The NDS tables include two cases: one for the loads parallel to the grains and one for the loads perpendicular to the grains. The loads that act at other angles involve the application of Hankinson formula, which has not been considered in this book.

A reference design value,  $Z$ , obtained by the yield limit equations or from the NDS tables, is then subjected to the adjustment factors to get the adjusted reference design value,  $Z'_n$ , to be used in Equation 8.1. The adjustment factors are discussed in the “Adjustments of the Reference Design Values” section.

## REFERENCE DESIGN VALUES FOR WITHDRAWAL LOADS

Dowel-type fasteners are much less stronger in withdrawal capacity. The reference design values for different types of fasteners in lb/in. of penetration is given by the empirical formulas, which are functions of the specific gravity of species and the diameter of the fasteners. The NDS provides the tables based on these formulas. The selected reference design values for withdrawal loading are included in the Appendix B, Tables B.11, B.13, B.15, B.18 for different types of fasteners.

## ADJUSTMENTS OF THE REFERENCE DESIGN VALUES

Table 8.1 specifies the adjustment factors that apply to the lateral loads and withdrawal loads for dowel-type fasteners.

The last three factors,  $K_F$ ,  $\phi_z$ , and  $\lambda$ , are relevant to load resistance factor design (LRFD) only. For connections, their values are

$$K_F = 3.32$$

$$\phi_z = 0.65$$

$\lambda$  = as given in the “Time Effect Factor,  $\lambda$ ” section in Chapter 6

The other factors are discussed below.

**TABLE 8.1**  
**Adjustment Factors for Dowel-Type Fasteners**

Loads	LRFD Only			Factors						
	Format Conversion	Resistance Factor	Time Effect	Wet Service	Temperature	Group Action	Geometry	End Grain	Diaphragm	Toenail
Lateral loads	$K_F$	$\phi_z$	$\lambda$	$C_M$	$C_t$	$C_g$	$C_\Delta$	$C_{eg}$	$C_{di}^a$	$C_m^a$
Withdrawal	$K_F$	$\phi_z$	$\lambda$	$C_M$	$C_t$	—	—	$C_{eg}$	—	$C_m^a$

<sup>a</sup> This factor applies to nails and spikes only.

**WET SERVICE FACTOR,  $C_M$** 

For connections, the listed reference design values are for seasoned wood having a moisture content of 19% or less. For wet woods or those exposed to wet conditions, the multiplying factors of less than 1 are specified in the NDS Table 10.3.3 of the *National Design Specification for Wood Construction* cited in the Bibliography.

**TEMPERATURE FACTOR,  $C_t$** 

For connections that will experience sustained exposure to higher than 100°F temperature, a factor of less than 1 shall be applied, as specified in the NDS Table 10.3.4 of the *National Design Specification for Wood Construction* cited in the Bibliography.

**GROUP ACTION FACTOR,  $C_g$** 

A row of fasteners consists of a number of fasteners in a line parallel to the direction of loading. The load carried by fasteners in a row is not equally divided among the fasteners; the end fasteners in a row carry a larger portion of the load as compared to the interior fasteners. The unequal sharing of loads is accounted for by the group action factor,  $C_g$ .

For dowel-type fasteners of diameter less than 1/4 in. (i.e., nails and wood screws),  $C_g = 1$ . For 1/4 in. or larger diameter fasteners,  $C_g$  is given by a formula, which is quite involved. The NDS provides tabulated values for simplified connections. The number of fasteners in a single row is the primary consideration. For bolts and lag screws, conservatively,  $C_g$  has the values indicated in Table 8.2 (nails and screws have  $C_g = 1$ ).

**GEOMETRY FACTOR,  $C_{\Delta}$** 

When the diameter of a fastener is less than 1/4 in. (nails and screws),  $C_{\Delta\Delta} = 1$ . For larger diameter fasteners, the geometry factor accounts for the end distance, edge distance, and spacing of fasteners, as defined in Figure 8.7.

1. The edge distance requirements, according to the NDS, are given in Table 8.3, where  $l/D$  is the lesser of the following:
  - a.  $\frac{l_m}{D} = \frac{\text{bearing length of bolt in main member}}{\text{bolt diameter}}$
  - b.  $\frac{l_s}{D} = \frac{\text{combined bearing length of bolt in all side members}}{\text{bolt diameter}}$
2. The spacing requirements between rows, according to the NDS, are given in Table 8.4, where  $l/D$  is defined above.
3. The end distance requirements, according to the NDS, are given in Table 8.5.
4. The spacing requirements for fasteners along a row, according to the NDS, are given in Table 8.6.

---

**TABLE 8.2**  
**Conservative Value of the Group Action Factor**

Number of Fasteners in One Row	$C_g$
2	0.97
3	0.89
4	0.80

---



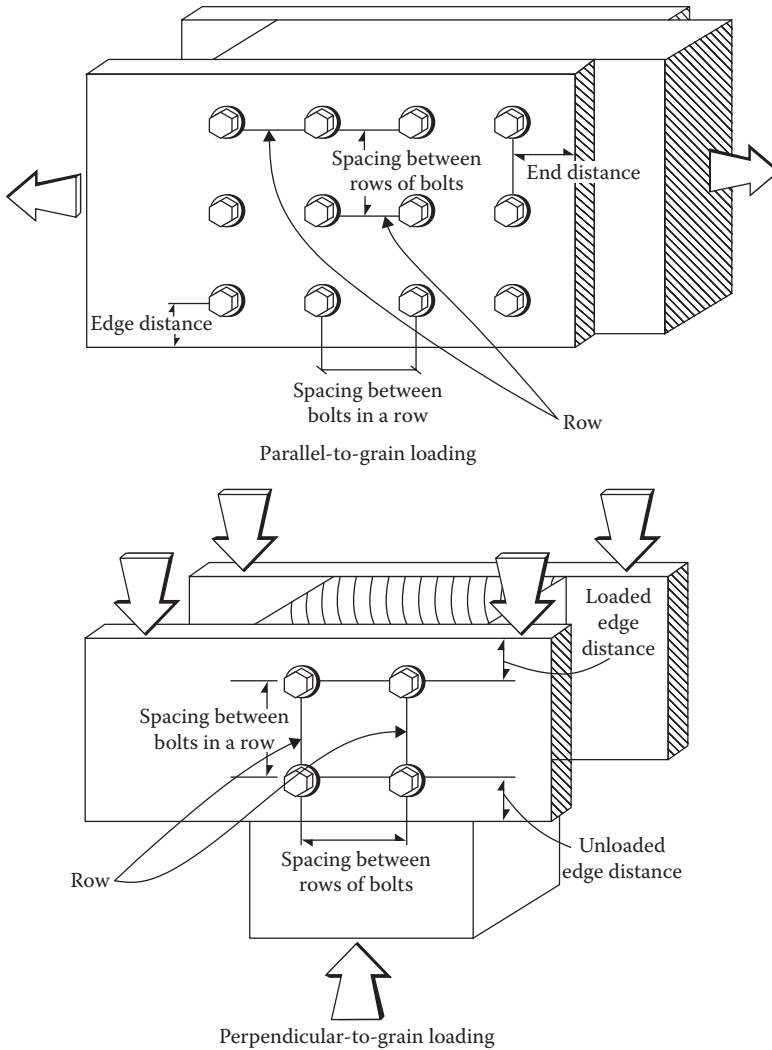


FIGURE 8.7 Connection geometry. (Courtesy of American Forest & Paper Association, Washington, DC.)

**TABLE 8.3**  
**Minimum Edge Distance**

Direction of Loading	Minimum Edge Distance
1. Parallel to grains	
When $l/D \leq 6$	$1.5D$
When $l/D > 6$	$1.5D$ or $1/2$ spacing between rows, whichever is greater
2. Perpendicular to grains	
Loaded edge	$4D$
Unloaded edge	$1.5D$

The provisions for  $C_{\Delta}$  are based on the assumption that the edge distance and the spacing between rows are met in accordance with Tables 8.3 and 8.4, respectively. In addition, the perpendicular to grain distance between the outermost fastener rows should not exceed 5 in. for sawn lumber and GLULAM with  $C_M = 1$ .

**TABLE 8.4**  
**Minimum Spacing between Rows**

Direction of Loading	Minimum Spacing
1. Parallel to grains	1.5D
2. Perpendicular to grains	
When $l/D \leq 2$	2.5D
When $l/D > 2$ but $< 6$	$(5l + 10D)/8$
When $l/D \geq 6$	5D

**TABLE 8.5**  
**Minimum End Distance**

Direction of Loading	End Distance for $C_{\Delta} = 1$	Minimum End Distance for $C_{\Delta} = 0.5$
1. Parallel to grains		
Compression	4D	2D
Tension—softwood	7D	3.5D
Tension—hardwood	5D	2.5D
2. Perpendicular to grains	4D	2D

**TABLE 8.6**  
**Minimum Spacing in a Row**

Direction of Loading	Spacing for $C_{\Delta} = 1$	Minimum Spacing
1. Parallel to grains	4D	3D
2. Perpendicular to grains	On side plates (attached member) spacing should be 4D	3D

The requirements for the end distance and the spacing along a row for  $C_{\Delta} = 1$  are given in the second column of Tables 8.5 and 8.6. The tables also indicate the (absolute) minimum requirements that must be provided for. When the actual end distance and the actual spacing along a row are less than those indicated for  $C_{\Delta} = 1$ , the value of  $C_{\Delta}$  should be computed by the following ratio:

$$C = \frac{\text{actual end distance or actual spacing along a row}}{\text{end distance for } C = 1 \text{ from Table 8.5 or spacing } C = 1 \text{ from Table 8.6}}$$

For fasteners located at an angle, the geometry factor,  $C_{\Delta}$ , also depends on the shear area. For  $C_{\Delta}$  to be 1, the minimum shear area of an angled member as shown in Figure 8.8 should be equal to the shear area of a parallel member connection having the minimum end distance as required for  $C_{\Delta} = 1$  from Table 8.5 as shown in Figure 8.9. If the angled shear area is less, the geometry factor  $C_{\Delta}$  is determined by the ratio of the actual shear area to that required for  $C_{\Delta} = 1$  from Figure 8.9.

The geometry factor is the smallest value determined from the consideration of the end distance, spacing along the row, and the angled shear area.

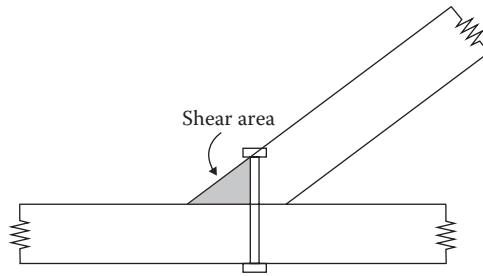


FIGURE 8.8 Shear area for fastener loaded at angle.

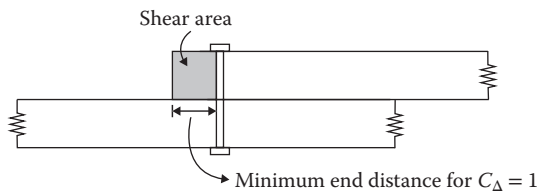


FIGURE 8.9 Shear area of parallel member connection.

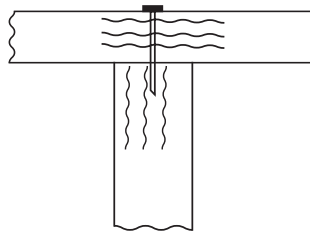


FIGURE 8.10 End grain factor.

### END GRAIN FACTOR, $C_{eg}$

In a shear connection, load is perpendicular to the length (axis) of the fastener, and in a withdrawal connection, load is parallel to the length of the fastener. But in both cases, the length (axis) of the fastener is perpendicular to the wood fibers (fastener is installed in the side grains). However, when a fastener penetrates an end grain so that the fastener axis is parallel to the wood fibers, as shown in Figure 8.10, it is a weaker connection.

For a withdrawal-type loading,  $C_{eg} = 0.75$ . For a lateral (shear)-type loading,  $C_{eg} = 0.67$ .

### DIAPHRAGM FACTOR, $C_{di}$

This applies to nails and spikes only. When nails or spikes are used in diaphragm construction,  $C_{di} = 1.1$ .

### TOENAIL FACTOR, $C_{tn}$

This applies to nails and spikes only. In many situations, it is not possible to directly nail a side member to a holding member. Toenails are used in the side member at an angle of about  $30^\circ$  and start at about  $1/3$  of the nail length from the intersection of the two members, as shown in Figure 8.11.

For lateral loads,  $C_{tn} = 0.83$ . For withdrawal loads,  $C_{tn} = 0.67$ . For withdrawal loads, the wet-service factor is not applied together with  $C_{tn}$ .

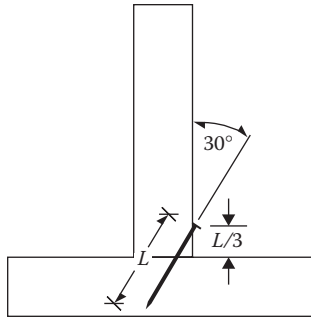


FIGURE 8.11 Toenail factor.

### Example 8.1

The reference lateral design value for the parallel-to-grain loaded lag screw connection shown in Figure 8.12 is 1110 lb. Determine the adjusted reference design value. The diameter of screws is 7/8 in. The connection is subjected to dead and live tensile loads in dry softwood at normal temperatures.

### SOLUTION

1. Adjusted reference design value,  $Z'_n = Z \times (\phi_z \lambda C_g C_\Delta K_f)$ ; since  $C_M$  and  $C_t = 1$
2.  $\phi_z = 0.65$
3.  $\lambda = 0.8$
4.  $K_f = 3.32$
5. Group action factor,  $C_g$   
For three fasteners in a row,  $C_g = 0.89$  (from Table 8.2)
6. Geometry factor,  $C_\Delta$ 
  - a. End distance = 4 in.
  - b. End distance for  $C_\Delta = 1$ ,  $7D = 7\left(\frac{7}{8}\right) = 6.125$  in.
  - c. End factor =  $\frac{4.0}{6.125} = 0.65 \leftarrow$  controls
  - d. Spacing along a row = 3 in.
  - e. Spacing for  $C_\Delta = 1$ ,  $4D = 3.5$  in.
  - f. Spacing factor =  $\frac{3.0}{3.5} = 0.857$
7.  $Z'_n = 1110(0.65)(0.8)(0.89)(0.65)(3.32) = 1108.6$  lb

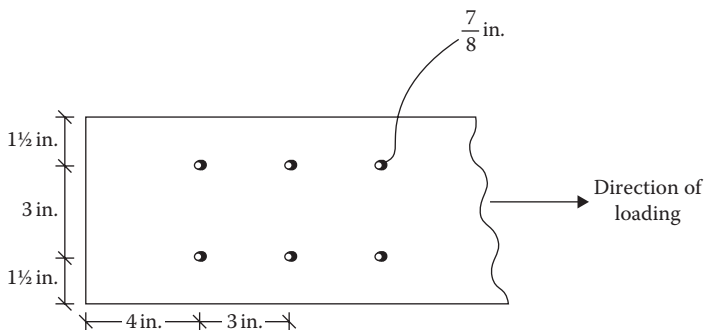


FIGURE 8.12 Parallel-to-grain loaded connection.

**Example 8.2**

The reference lateral design value for the perpendicular-to-grain loaded bolted connection shown in Figure 8.13 is 740 lb. Determine the adjusted reference design value. The bolt diameter is  $\frac{7}{8}$  in. Use soft dry wood and normal temperature conditions. The connection is subjected to dead and live loads.

**SOLUTION**

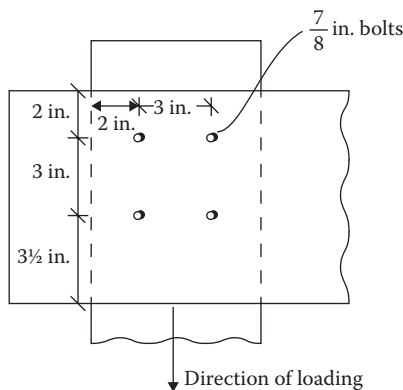
- Adjusted reference design value,  $Z'_n = Z \times (\phi_z \lambda C_g C_\Delta K_f)$ ; since  $C_M$  and  $C_t = 1$
- $\phi_z = 0.65$
- $\lambda = 0.8$
- $K_f = 3.32$
- Group action factor,  $C_g$   
For two fasteners in a row,  $C_g = 0.97$  (from Table 8.2)
- Geometry factor,  $C_\Delta$ 
  - End distance = 2 in.
  - End distance for  $C_\Delta = 1$ ,  $4D = 4\left(\frac{7}{8}\right) = 3.5$  in.
  - End factor =  $\frac{2.0}{3.5} = 0.57 \leftarrow$  controls
  - Spacing along a row = 3 in.
  - Spacing for  $C_\Delta = 1$ ,  $4D = 4\left(\frac{7}{8}\right) = 3.5$  in.
  - Spacing factor =  $\frac{3.0}{3.5} = 0.857$
- $Z'_n = 740(0.65)(0.80)(0.97)(0.57)(3.32) = 706.3$  lb

**Example 8.3**

The connection of Example 8.1 when loaded in withdrawal mode has a reference design value of 500 lb. Determine the adjusted reference withdrawal design value.

**SOLUTION**

- Adjusted reference design value,  $Z'_n = Z \times (\phi_z \lambda K_f)$ ;
- $\phi_z = 0.65$
- $\lambda = 0.8$
- $K_f = 3.32$
- $Z'_n = 500(0.65)(0.80)(3.32) = 863$  lb



**FIGURE 8.13** Perpendicular-to-grain loaded connection.

## NAIL AND SCREW CONNECTIONS

Once the adjusted reference design value is determined, Equation 8.1 can be used with the factored load to design a connection for any dowel-type fasteners. Nails and wood screws generally fall into small-size fasteners having a diameter of less than 1/4 in. For small-size fasteners, the angle of load with respect to grains of wood is not important. Moreover, the group action factor,  $C_g$ , and the geometry factor,  $C_{\Delta}$ , are not applicable. The end grain factor,  $C_{eg}$ , the diaphragm factor,  $C_{di}$ , and the toenail factor,  $C_{tn}$ , apply to specific cases. Thus, for a common type of dry wood under normal temperature conditions, no adjustment factors are required except for the special LRFD factors of  $\phi_z$ ,  $\lambda$ , and  $K_F$ .

The basic properties of nails and wood screws are described below.

### COMMON, BOX, AND SINKER NAILS

Nails are specified by the pennyweight, abbreviated as  $d$ . A nail of a specific pennyweight has a fixed length,  $L$ , shank diameter,  $D$ , and head size,  $H$ . There are three kinds of nails: common, box, and sinker. Common and box nails have a flat head and sinker nails have a countersunk head, as shown in Figure 8.14.

For the same pennyweight, box and sinker nails have a smaller diameter and, hence, a lower capacity as compared to common nails.

The reference lateral design values for the simple nail connector are given in Appendix B, Table B.10. The values for the other cases are included in the NDS specifications. The reference withdrawal design values for nails of different sizes for various wood species are given in Appendix B, Table B.11.

### POST-FRAME RING SHANK NAILS

These are threaded nails. There are two types of threads. In annular nails, the threads are perpendicular to the nail axis. The threads of helical nails are aligned at an angle between 30° and 70° to the nail axis. The annular nails are called the post-frame ring shank nails, as shown in Figure 8.15. The threaded nails have higher withdrawal strength because of wood fibers lodged between the threads.

The typical dimensions of post-frame ring shank nails are given in Table 8.7. The reference design values for post-frame ring shank nails using a single-shear connection are given in Appendix B, Table B.12. The reference withdrawal design values per inch penetration are given in Appendix B, Table B.13.

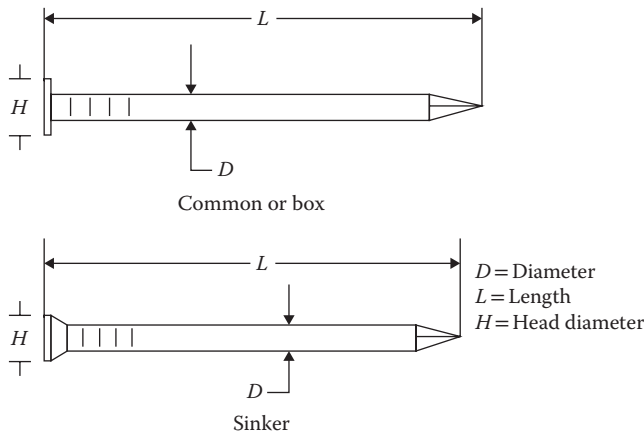


FIGURE 8.14 Typical specifications of nails.

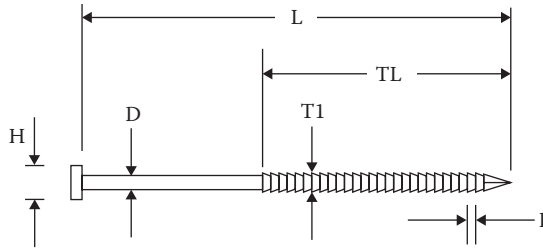


FIGURE 8.15 Typical specifications of post-frame ring shank nails.

**TABLE 8.7**  
**Typical Dimensions of Post-Frame Ring Shank Nails**

$D$ (in.)	$L$ (in.)	$H$ (in.)	Root Diameter, $D_r$ (in.)
0.135	3, 3.5	5/16	0.128
0.148	3, 3.5, 4, 4.5	5/16	0.140
0.177	3, 3.5, 4, 4.5, 5, 6, 8	3/8	0.169
0.20	3.5, 4, 4.5, 5, 6, 8	15/32	0.193
0.207	4, 4.5, 5, 6, 8	15/32	0.199

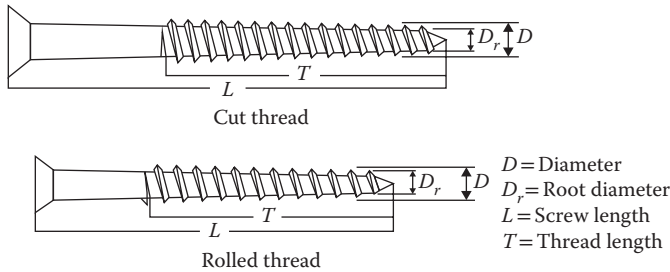


FIGURE 8.16 Typical specifications of wood screws.

**WOOD SCREWS**

Wood screws are identified by a number. A screw of a specific number has a fixed diameter (outside to outside of threads) and a fixed root diameter, as shown in Figure 8.16. Screws of each specific number are available in different lengths. There are two types of screws: *cut thread screws* and *rolled thread screws*. The thread length,  $T$ , of a cut thread screw is approximately 2/3 of the screw length,  $L$ . In a rolled thread screw, the thread length,  $T$ , is at least four times the screw diameter,  $D$ , or 2/3 of the screw length,  $L$ , whichever is greater. The screws that are too short to accommodate the minimum thread length have threads extended as close to the underside of the head as practical.

The screws are inserted in their lead hole by turning with a screwdriver; they are not driven by a hammer. The minimum penetration of the wood screw into the main member for single shear or into the side member for double shear should be six times the diameter of the screw. Wood screws are not permitted to be used in a withdrawal-type connection in end grain.

The reference lateral design values for simple wood screw connections are given in Appendix B, Table B.14. The values for other cases are included in the NDS specifications. The reference withdrawal design values for wood screws are given in Appendix B, Table B.15.

**Example 8.4**

A 2 in. × 6 in. diagonal member of No. 1 Southern Pine is connected to a 4 in. × 6 in. column, as shown in Figure 8.17. It is acted upon by a service wind load component of 2 k. Design the nailed connection. Neglect the dead load.

**SOLUTION**

1. Factored design load,  $R_z = 1(2) = 2$  k or 2000 lb
2. Use 30d nails, 3 in a row
3. Reference design value for a side thickness of 1.5 in.  
From Appendix B, Table B.10,  $Z = 203$  lb
4. For nails, the adjusted reference design value

$$Z'_n = Z \times (\phi_z \lambda K_F)$$

where

$$\phi_z = 0.65$$

$$\lambda = 1.00$$

$$K_F = 3.32$$

$$Z'_n = 203(0.65)(1)(3.32) = 438 \text{ lb}$$

5. From Equation 8.1

$$N = \frac{R_z}{Z'_n} = \frac{2000}{438} = 4.57 \text{ nails}$$

6. For number of nails per row,  $n = 3$

$$\text{Number of rows} = \frac{4.57}{3} = 1.52 \text{ (use 2)}$$

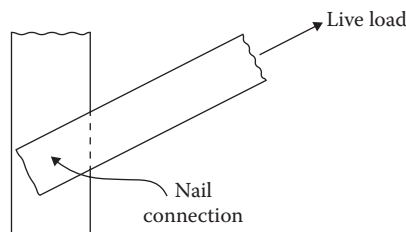
Provide 2 rows of 3 nails each of 30d size

**BOLT AND LAG SCREW CONNECTIONS**

Bolts and lag screws are used for larger loads. The angle of load to grains is an important consideration in large diameter ( $\geq 1/4$  in.) connections comprising bolts and lag screws. However, this book makes use of the reference design tables, in lieu of the yield limit equations, which include only the two cases of parallel-to-grain and perpendicular-to-grain conditions. The group action factor,  $C_g$ , and the geometry factor,  $C_\Delta$ , apply to bolts and lag screws. Although the end grain factor,  $C_{eg}$ , is applicable, it is typical to a nail connection. The other two factors, the diaphragm factor,  $C_{di}$ , and the toenail factor,  $C_m$ , also apply to nails.

An important consideration in bolt and lag screw connection design is to accommodate the number of bolts and rows within the size of the connecting member satisfying the requirements of the end, edge, and in-between bolt spacing.

The larger diameter fasteners often involve the use of prefabricated steel accessories or hardware. The NDS provides details of the typical connections involving various kinds of hardware.



**FIGURE 8.17** Diagonal member nail connection.



## BOLTS

In steel structures, the trend is to use high-strength bolts. However, this is not the case in wood structures where low-strength A307 bolts are commonly used. Bolt sizes used in wood construction range from 1/2 in. through 1 in. diameter, in increments of 1/8 in. The NDS restricts the use of bolts to a largest size of 1 in. The bolts are installed in the predrilled holes. The NDS specifies that the hole size should be a minimum of 1/32 in. to a maximum of 1/16 in. larger than the bolt diameter for uniform development of the bearing stress.

Most bolts are used in the lateral-type connections. They are distinguished by the single-shear (two members) and double-shear (three members) connections. For more than double shear, the single-shear capacity at each shear plane is determined and the value of the weakest shear plane is multiplied by the number of shear planes.

The connections are further recognized by the types of main and side members, such as wood-to-wood, wood-to-metal, wood-to-concrete, and wood-to-masonry connections. The last two are simply termed as *anchored* connections.

Washers of adequate size are provided between the wood member and the bolt head, and between the wood member and the nut. The size of the washer is not of significance in shear. For bolts in tension and compression, the size should be adequate so that the bearing stress is within the compression strength perpendicular to the wood grain.

The reference lateral design values for a simple bolted connection are given in Appendix B, Table B.16

## LAG SCREWS

Lag screws are relatively larger than wood screws. They have wood screw threads and a square or hexagonal bolt head. The dimensions for lag screws include the nominal length,  $L$ ; diameter,  $D$ ; root diameter,  $D_r$ ; unthreaded shank length,  $S$ ; minimum thread length,  $T$ ; length of tapered tip,  $E$ ; number of threads per in.,  $N$ ; height of head,  $H$ ; and width of head across flats,  $F$ , as shown in Figure 8.18.

Lag screws are used when an excessive length of bolt will be required to access the other side or when the other side of a through-bolted connection is not accessible. Lag screws are used in shear as well as in withdrawal applications.

Lag screws are installed with a wrench as opposed to wood screws, which are installed by screwdrivers. Lag screws involved pre-bored holes with two different diameter bits. The larger diameter hole has the same diameter and length as the unthreaded shank of the lag screw and the lead hole for the threaded portion is similar to that for wood screw, the size of which depends on the specific gravity of the wood. The minimum penetration (excluding the length of the tapered tip) into the main member for single shear and into the side member for double shear should be four times the lag screw diameter,  $D$ .

The reference lateral design values for simple lag screw connection are given in Appendix B, Table B.17. The other cases are included in the NDS specifications. The reference withdrawal design values for lag screws are given in Appendix B, Table B.18.

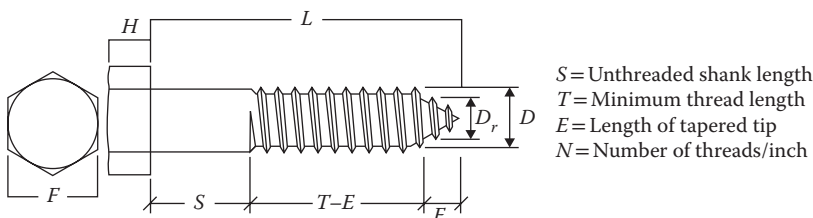


FIGURE 8.18 Typical specifications of log screws.

**Example 8.5**

The diagonal member of Example 8.4 is subjected to a wind load component of 4 k. Design the bolted connection. Use 5/8-in. bolts.

**SOLUTION**

1. Factored design load,  $R_z = 1(4) = 4$  k or 4000 lb
2. Use 5/8-in. bolts, two in a row
3. Reference design value
  - a. For a side thickness of 1.5 in.
  - b. Main member thickness of 3.5 in.
  - c. From Appendix B, Table B.16,  $Z = 940$  lb
4. Adjusted reference design value,  $Z'_n = Z \times (\phi_z \lambda C_g C K_f)$
5.  $\phi_z = 0.65$   
 $\lambda = 1.0$   
 $K_f = 3.22$
6. Group action factor,  $C_g$   
 For two fasteners in a row,  $C_g = 0.97$  (from Table 8.2)
7. Geometry factor,  $C_\Delta$ 
  - a. End distance to accommodate within 6 in. column size = 2.5 in.
  - b. Spacing within 6 in. column = 2 in.
  - c. End distance for  $C_\Delta = 1$ ,  $7D = 4.375$  in.
  - d. End factor =  $\frac{2.5}{4.375} = 0.57 \leftarrow$  controls
  - e. Spacing  $C_\Delta = 1$ ,  $4D = 2.5$  in.
  - f. Spacing factor =  $\frac{2}{2.5} = 0.8$
8.  $Z'_n = 940(0.65)(1)(0.97)(0.57)(3.22) = 1087.8$  lb
9. From Equation 8.1
 
$$N = \frac{R_z}{Z'_n} = \frac{4000}{1087.8} = 3.7$$
10. Number of bolts per row,  $n = 2$   
 Number of rows =  $\frac{3.7}{2} = 1.85$  (use 2)  
 Provide 2 rows of two 5/8-in. bolts

**PROBLEMS**

- 8.1** The reference lateral design value of a parallel-to-grain loaded lag screw connection shown in Figure P8.1 is 740 lb. The screw diameter is 5/8 in. The loads comprise dead and live loads. Determine the adjusted reference design value for soft dry wood at normal temperature.
- 8.2** The reference lateral design value of a perpendicular-to-grain loaded lag screw connection shown in Figure P8.2 is 500 lb. The screw diameter is 5/8 in. The loads comprise dead and live loads. Determine the adjusted reference design value for soft dry wood at normal temperature.
- 8.3** The connection in Problem 8.1 has a reference withdrawal design value of 400 lb. Determine the adjusted reference design value.
- 8.4** Problem 8.2 is a nailed connection by 0.225-in.-diameter nails. The holding member has fibers parallel to the nail axis. The reference design value is 230 lb. Determine the adjusted reference design value.

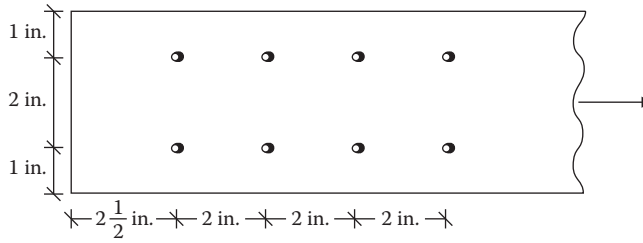


FIGURE P8.1 Parallel-to-grain screw connection for Problem 8.1.

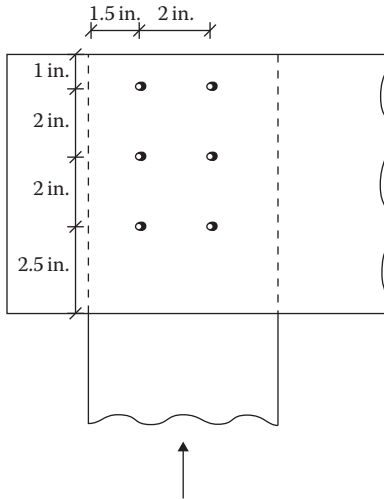


FIGURE P8.2 Perpendicular-to-grain screw connection for Problem 8.2.

- 8.5 A spliced parallel-to-grain-loaded connection uses two rows of 7/8-in. lag screws with three fasteners in each row, as shown in Figure P8.3. The load carried is  $1.2D + 1.6L$ . The reference design value is 1500 lb. The connection is in hard dry wood at normal temperature. Determine the adjusted reference design value.
- 8.6 The connection in Problem 8.5 is subjected to a perpendicular-to-grain load from the top only. The reference design value is 1000 lb. Determine the adjusted reference design value.
- 8.7 The connection in Problem 8.5 is subjected to withdrawal loading. The reference design value is 500 lb. Determine the adjusted reference design value.
- 8.8 The connection shown in Figure P8.4 uses 3/4-in.-diameter bolts in a single shear. There are two bolts in each row. The reference design value is 2000 lb. It is subjected to lateral wind load only (no live load). Determine the adjusted reference design value for soft dry wood at normal temperature.
- 8.9 For the connection shown in Figure P8.5, the reference design value is 1000 lb. Determine the adjusted reference design value for dry wood under normal temperature conditions.
- 8.10 Toenails of 50d pennyweight (0.244 in. diameter, 5½ in. length) are used to connect a beam to the top plate of a stud wall, as shown in Figure P8.6. It is subjected to dead and live loads. The lateral reference design value is 250 lb. Determine the adjusted reference design value for soft wood under normal temperature and dry conditions. Show the connection.

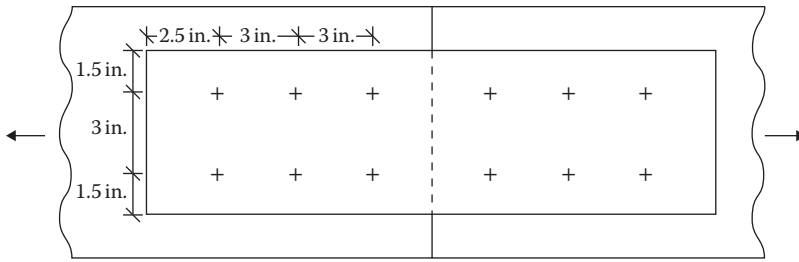


FIGURE P8.3 Spliced parallel-to-grain connection.

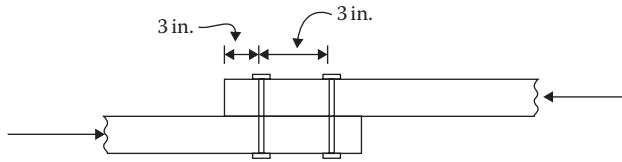


FIGURE P8.4 A single shear connection.

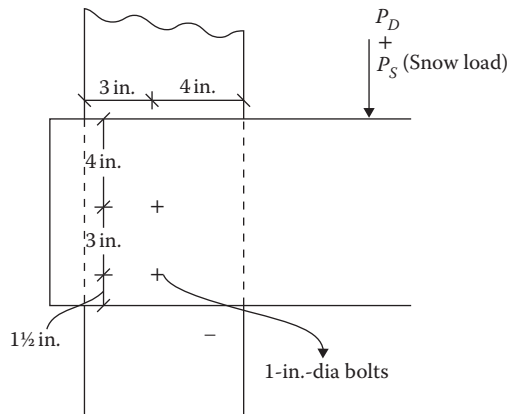


FIGURE P8.5 Perpendicular-to-grain bolted connection for Problem 8.9.

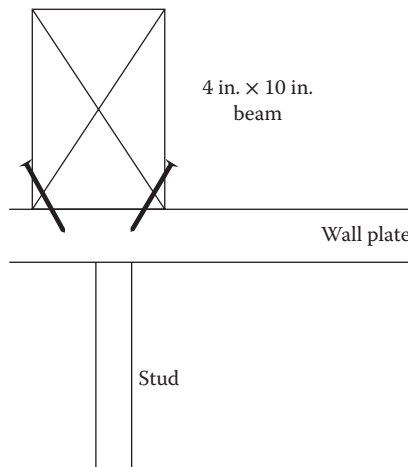
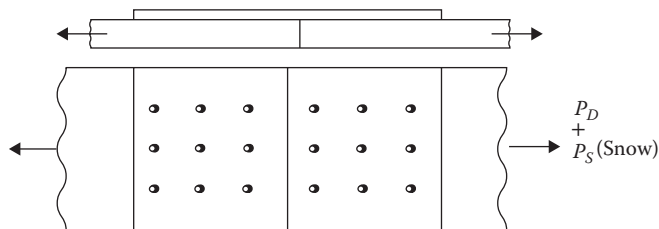
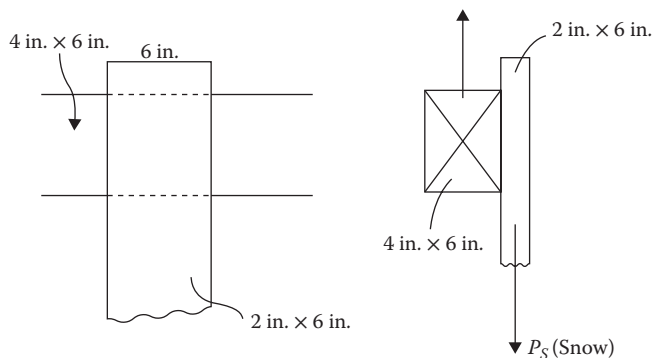


FIGURE P8.6 Toenail connection to a top plate.

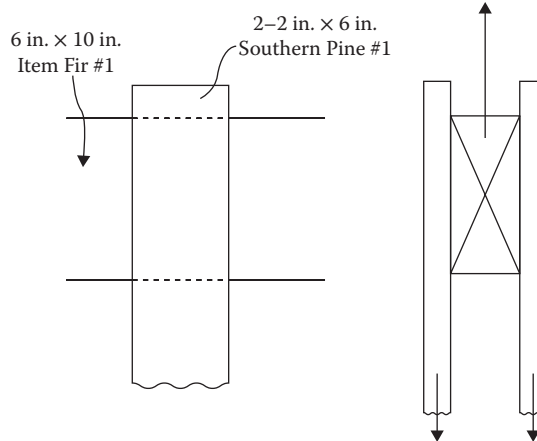
- 8.11** Design a nail connection to transfer tensile service dead and live loads of 400 and 600 lb, respectively, acting along the axis of a 2 in.  $\times$  6 in. diagonal member connected to a 4 in.  $\times$  4 in. vertical member. Use No. 1 Southern Pine soft dry wood. Assume two rows of 30d common nails.
- 8.12** A 2 in.  $\times$  8 in. diagonal member is connected by 20d common nails to a 4 in.  $\times$  6 in. vertical member. It is acted upon by a combined factored dead and snow load of 1.5 k. Design the connection. Use Douglas Fir-Larch dry wood ( $G = 0.5$ ).
- 8.13** Determine the tensile capacity of a spliced connection acted upon by the dead and snow loads. The joint connects two 2 in.  $\times$  6 in. No. 1 Southern Pine members together by 10d common nails via one side plate of 1 in. thickness, as shown in Figure P8.7.
- 8.14** Two 2 in.  $\times$  8 in. members of Douglas Fir-Larch ( $G = 0.5$ ) are to be spliced connected via a single 1½-in.-thick plate on top with two rows of #9 size screws. The service loads comprise 200 lb of dead load and 500 lb of live load that act normal to the fibers. Design the connection.
- 8.15** Southern Pine #1, 10-ft.-long 2 in.  $\times$  4 in. wall studs, spaced at 16 in. on center (OC) are toenailed on to Southern Pine #1 top and bottom plates with two 10d nails at each end. The horizontal service wind load of 30 psf acts on the studs. Is the connection adequate?
- 8.16** The service dead load and live load in Problem 8.11 are doubled. Design a lag screw connection using 1/2-in.-lag screws. Assume the edge distance, end distance, and bolt spacing along the diagonal of 2 in. each.  
[Hint: Only two bolts per row can be arranged along the diagonal within a 4  $\times$  4 column size.]
- 8.17** A 2 in.  $\times$  6 in. is connected to a 4 in.  $\times$  6 in. member, as shown in Figure P8.8. Design a 1/2 in. lag screw connection to transfer the dead and snow (service) loads of 0.4 k and 1.2 k, respectively. The wood is soft Hem Fir-Larch No. 1 in dry conditions at normal temperature.  
[Hint: For a beam size of 6 in., only three bolts can be arranged per row of the vertical member.]



**FIGURE P8.7** A spliced nail connection.



**FIGURE P8.8** A beam-column shear connection.



**FIGURE P8.9** A beam–column double-shear connection.

- 8.18** Determine the number and placement of 5/8-in. bolts to transfer the service dead and snow loads of 0.2 k and 2.85 k, respectively, through a joint, as shown in Figure P8.9. The single shear reference design value is 830 lb, which should be doubled for two shear planes.
- 8.19** The controlling load on the structural member in Problem 8.17 is an unfactored wind load of 3.2 k that acts horizontally. Design the 1/2-in. bolted connection.  
*[Hint: Load acts normal to the grain and three rows can be arranged within the column size for the horizontally acting load.]*
- 8.20** The main members of 3 in. x 10 in. are spliced connected by one 2 in. x 10 in. side member of Southern Pine #1 soft dry wood. The connection consists of six 1-in. bolts in two rows in each splice. Determine the joint capacity for dead and live loads. The end distance and bolt spacing are 3.5 in. each. If the dead load is one-half of the live load, what is the magnitude of each load?

# *Section III*

---

## *Steel Structures*





---

# 9 Tension Steel Members

## PROPERTIES OF STEEL

Steel structures commonly consist of frames, cables and trusses, and plated structures. The bracing in the form of diagonal members provides the lateral stiffness. For steel elements, generally, the standard shapes, which are specified according to the American Society of Testing Materials (ASTM) standards, are used. The properties of these elements are listed in the beginning of the manual of the American Institute of Steel Construction (AISC) under Dimensions and Properties section. A common element is an I-shaped section having horizontal flanges that are connected at the top and bottom of a vertical web. This type of section is classified into W, M, S, and HP shapes, the difference in these shapes essentially being in the width and thickness of flanges. A typical designation “W14 × 68” means a wide flange section having a nominal depth of 14 in. and a weight of 68 lb/ft. of length. The other standard shapes are channels (C and MC), angles (L), and tees (WT, MT, and ST).

Tubular shapes are common for compression members. The rectangular and square sections are designated by the letters HSS along with the outer dimensions and the wall thickness. The round tubing is designated as HSS round (for Grade 42) and pipes (for Grade 35) along with the outer diameter and the wall thickness. The geometric properties of the frequently used wide flange sections are given in Appendix C, Table C.1a and b, with those for channel sections in Appendix C, Table C.2a and b, angle sections in Appendix C, Table C.3a through c, rectangular tubing in Appendix C, Table C.4a and b, square tubing in Appendix C, Table C.5, round tubing in Appendix C, Table C.6, and pipes in Appendix C, Table C.7.

The structural shapes are available in many grades of steel classified according to the ASTM specifications. The commonly used grades of steel for various structural shapes are listed in Table 9.1.

The yield strength is a very important property of steel because so many design procedures are based on this value. For all grades of steel, the modulus of elasticity is practically the same at a level of  $29 \times 10^3$  ksi, which means the stress–strain relation of all grades of steel is similar.

A distinguished property that makes steel a very desirable structural material is its ductility—a property that indicates that a structure will withstand an extensive amount of deformation under very high level of stresses without failure.

## PROVISIONS TO DESIGN STEEL STRUCTURES

The AISC *Specification for Structural Steel Buildings* (AISC 360) is intended to cover common design criteria. This document forms a part of the AISC *Steel Construction Manual*. However, it is not feasible to cover within such a document all special and unique problems that are encountered within the full range of the structural design. Accordingly, AISC 360 covers the common structures of low seismicity and a separate AISC document, *Seismic Provisions for Structural Steel Buildings* (AISC 341), addresses the high-seismic applications. The latter document is incorporated within the *Seismic Design Manual*.

The seismic provisions are not required for following structures, which are designed according to AISC 360:

1. Structures in seismic design category A
2. Structures in seismic design categories B and C where the response modification factor (coefficient),  $R$ , is not greater than 3

**TABLE 9.1**  
**Common Steel Grades**

ASTM Classification	Yield Strength, $F_y$ (ksi)	Ultimate Strength, $F_u$ (ksi)	Applicable Shapes
A36	36	58	W, M, S, HP, L, C, MC, WT
A572 Grade 50	50	65	Same
A992 Grade 50	50	65	Same
A500 Grade B	46	58	HSS—rectangular and square
A500 Grade B	42	58	HSS—round
A53 Grade B	35	60	Pipe—round

## UNIFIED DESIGN SPECIFICATIONS

A major unification of the codes and specifications for structural steel buildings has been accomplished by the AISC. Formerly, the AISC provided four design publications, one separately for the allowable stress design (ASD) method, the load resistance factor design (LRFD) method, the single-angle members, and the hollow tubular structural sections. However, the 13th edition of the *Steel Construction Manual* of AISC 2005 combined all these provisions in a single volume. Additionally, the 2005 AISC specifications established common sets of requirements for both the ASD and LRFD methods for analyses and designs of structural elements.

The 14th edition of the *Steel Construction Manual* of AISC 2010 updated the tables of element shapes to conform to ASTM A6-09. This comprised of adding and deleting some shapes and slightly changing some areas in some cases.

The factors unifying the two methods are as follows:

1. The nominal strength is the limiting state for failing of a steel member under different modes like compression, tension, or bending. It is the capacity of the member. The same nominal strength applies to both the ASD and LRFD methods of design.
2. For ASD, the available strength is the allowable strength, which is the nominal strength divided by a factor of safety. The available strength for LRFD is the design strength, which is the nominal strength multiplied by a resistance (uncertainty) factor.
3. The required strength for a member is given by the total of the service loads that act on the structure for the ASD method. The required strength for the LRFD method is given by the total of the factored (magnified) loads.
4. The required strength for loads should be within the available strength of the material.

Since the allowable strength of ASD and the design strength of LRFD are both connected with the nominal strength as indicated in item 2, there can be a direct relationship between the factor of safety of ASD and the resistance factor of LRFD. This was discussed in the “Working Stress Design, Strength Design, and Unified Design of Structures” section in Chapter 1.

## LIMIT STATES OF DESIGN

All designs are based on checking that the limit states are not exceeded. For each member type (tensile, column, beam), the AISC specifications identify the limit states that should be checked. The limit states consider all possible modes of failures like yielding, rupture, and buckling, and also consider the serviceability limit states like deflection and slenderness.

The limit states design process consists of the following:

1. Determine all applicable limit states (modes of failures) for the type of member to be designed.
2. Determine the expression for the nominal strength (and the available strength) with respect to each limit state.
3. Determine the required strength from the consideration of the loads applied on to the member.
4. Configure the member size by equating items 2 and 3 of this section.

In ASD, safety is established through a safety factor, which is independent of the types of loading. In LRFD, safety is established through a resistance factor and a load factor that varies with load types and load combinations.

## DESIGN OF TENSION MEMBERS

In the *AISC Manual* (2010), Chapter D of Part 16 applies to members that are subject to axial tension and Section J4 of Chapter J applies to connections and connecting elements like gusset plates that are in tension.

The limiting states for the tensile members and the connecting elements are controlled by the following modes:

1. Tensile strength
2. Shear strength of connection
3. Block shear strength of connection along the shear/tension failure path

The shear strength of connection (item 2) will be discussed in Chapter 13 on steel connections.

## TENSILE STRENGTH OF ELEMENTS

The serviceability limit state of the slenderness ratio  $L/r^*$  being less than 300 for members in tension is not mandatory in the new specifications although Section D1 recommends this value of 300 except for rods and hangers.

The design tensile strength of a member shall be the lower of the values obtained for the limit states of (1) the *tensile yielding* at the gross area and (2) the *tensile rupture* at the net area.

Thus, the strength is the lower of the following two values:

Based on the limit state of yielding in the gross section

$$P_u = 0.9F_yA_g \quad (9.1)$$

Based on the limit state of rupture in the net section

$$P_u = 0.75F_uA_e \quad (9.2)$$

where

$P_u$  is factored design tensile load

$F_y$  is yield strength of steel

---

\*  $L$  is the length of the member and  $r$  is the radius of gyration given by  $\sqrt{I/A}$ .

$F_u$  is ultimate strength of steel  
 $A_g$  is gross area of member  
 $A_e$  is effective net area

In connecting members, if a portion of a member is not fully connected like a leg of an angle section, the unconnected part is not subjected to the full stress. This is referred to as a *shear leg*. A factor is used to account for the shear lag. Thus,

$$A_e = A_n U \tag{9.3}$$

where

$A_n$  is net area  
 $U$  is shear lag factor

**NET AREA,  $A_n$**

The net area is the product of the thickness and the net width of a member. To compute net width, the sum of widths of the holes for bolts is subtracted from the gross width. The hole width is taken as 1/8 in. greater than the bolt diameter.

For a chain of holes in a zigzag line shown as a-b in Figure 9.1, a quantity  $s^2/4g$  is added to the net width for each zigzag of the gage space,  $g$ , in the chain. Thus,

$$A_n = bt - \sum ht + \sum \left( \frac{s^2}{4g} \right) t \tag{9.4}$$

where

$s$  is longitudinal (in the direction of loading) spacing between two consecutive holes (pitch)  
 $g$  is transverse (perpendicular to force) spacing between the same two holes (gage)  
 $b$  is width of member  
 $t$  is thickness of member  
 $h$  is size of hole

For angles, the gage for holes in the opposite legs, as shown in Figure 9.2, is  $g = g_1 + g_2 - t$ .

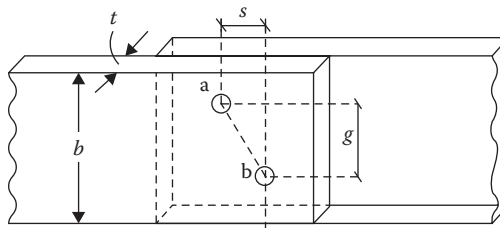


FIGURE 9.1 Zigzag pattern of holes.

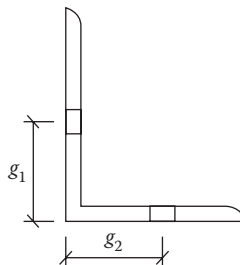


FIGURE 9.2 Gage for holes in angle section.

**Example 9.1**

An angle  $L 5 \times 5 \times 1/2^*$  has a staggered bolt pattern, as shown in Figure 9.3. The holes are for bolts of  $7/8$  in. diameter. Determine the net area.

**SOLUTION**

1.  $A_g = 4.79 \text{ in.}^2, t = 0.5 \text{ in.}$
2.  $h = d + (1/8) = (7/8) + (1/8) = 1 \text{ in.}$
3.  $g = g_1 + g_2 - t = 3 + 2 - 0.5 = 4.5 \text{ in.}$
4. Section through line a-b-d-e: deducting for two holes

$$A_n = A_g - \sum ht$$

$$= 4.79 - 2(1)(0.5) = 3.79 \text{ in.}^2$$

5. Section through line a-b-c-d-e: deducting for three holes and adding  $s^2/4g$  for b-c and c-d

$$A_n = A_g - 3ht + \left(\frac{s^2}{4g}\right)_{bc} t + \left(\frac{s^2}{4g}\right)_{cd} t$$

$$= 4.79 - 3(1)(0.5) + \left[\frac{2^2}{4(4.5)}\right] 0.5 + \left[\frac{2^2}{4(1.5)}\right] 0.5$$

$$= 3.71 \text{ in.}^2 \leftarrow \text{Controls}$$

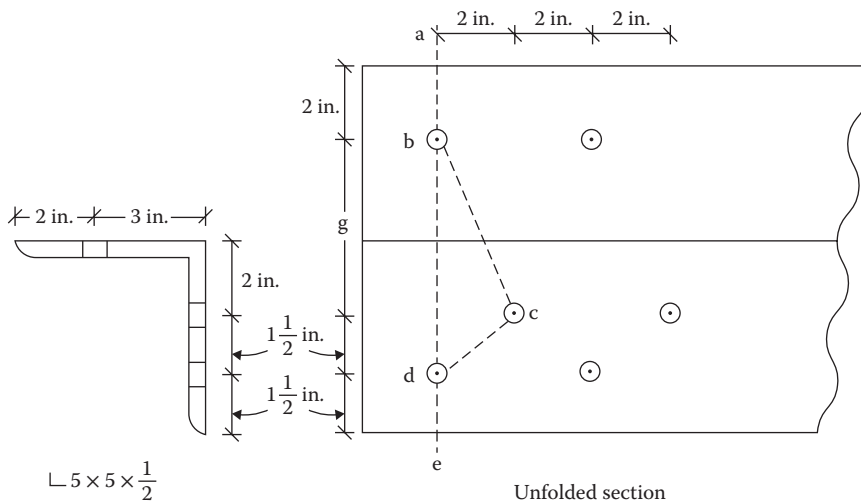
**EFFECTIVE NET AREA,  $A_e$**

1. *Plates with bolted connections*

As the flat plates are fully in contact and the entire area participates in transmitting the load, the shear lag factor,  $U = 1$ .

But for bolted slice plates, the net effective area should not be more than 85% of the gross area. Thus,

$$A_e = A_n \leq 0.85A_g \tag{9.5}$$



**FIGURE 9.3** Bolt pattern for Example 9.1.

\* Properties of this section not included in the appendix.

2. *Plates with welded connections*

For the transverse weld in Figure 9.4,  $U = 1$ ,  $A_e = A_n = A_g$ .

For the longitudinal weld in Figure 9.5,

When  $L \geq 2w$ ,  $U = 1$ .

When  $L < 2w$  and  $\geq 1.5w$ ,  $U = 0.87$ .

When  $L < 1.5w$ ,  $U = 0.75$ .

3. *Rolled sections with bolted connections*

For all sections other than plates and HSS (hollow round or rectangular tube),  $U$  can be given by

$$U = 1 - \frac{\bar{x}}{L} \quad (9.6)$$

where

$\bar{x}$  is eccentricity, that is, the distance from the connection plane to the centroid of the resisting member

$L$  is length of connection as shown in Figure 9.6

In lieu of Equation 9.6, the following values can be used:

For Angle Shapes

For single or double angles with four or more bolts in the direction of loading,  $U = 0.8$ .

For single or double angles with three bolts in the direction of loading,  $U = 0.60$ .

For single or double angles with less than three bolts in the direction of loading, use Equation 9.6.

For W, M, S, HP, and T Shapes

Flange connected with three or more bolts

$b_f \geq 2/3 d$   $U = 0.9$

$b_f < 2/3 d$   $U = 0.85$

Web connected with four or more bolts,  $U = 0.70$ .

For other cases not listed above, use Equation 9.6.

4. *Rolled sections with welded connections*

For a transverse weld,  $U = 1$  ( $A_n$  is the area of the directly connected element).

For a longitudinal and transverse weld combination, use Equation 9.6.

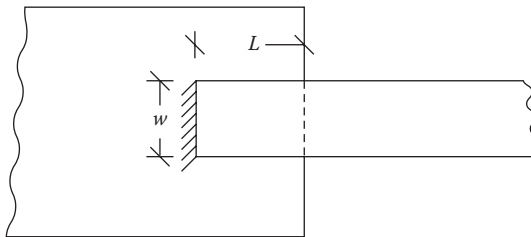


FIGURE 9.4 Transverse weld.

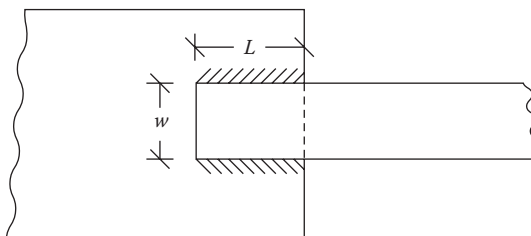


FIGURE 9.5 Longitudinal weld.

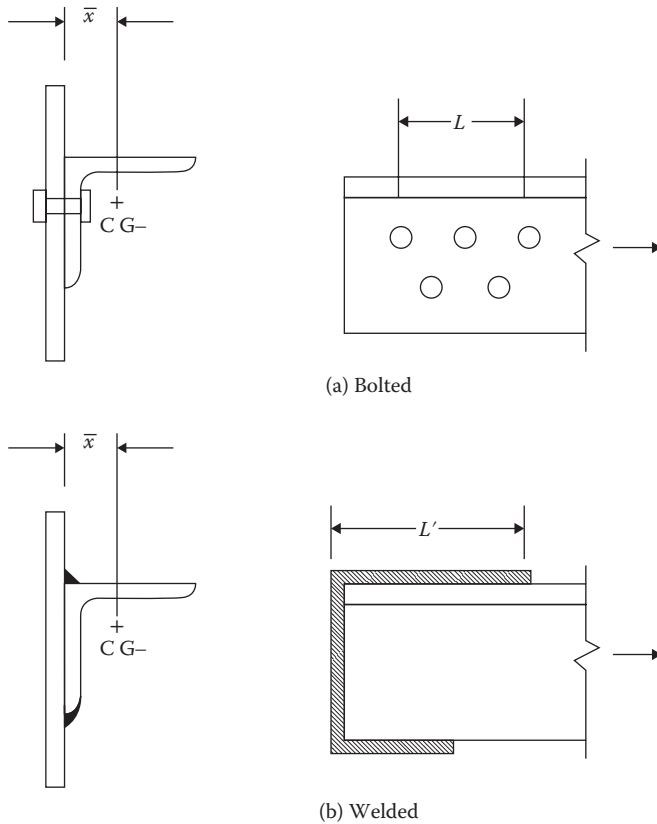


FIGURE 9.6 Eccentricity of the resisting member.

### Example 9.2

Determine the effective net area for the single-angle member in Example 9.1.

### SOLUTION

1. Since the number of bolts in the direction of loading is 3,  $U = 0.6$ .
2. From Example 9.1,  $A_n = 3.69 \text{ in.}^2$
3.  $A_e = A_n U = (3.69)(0.6) = 2.21 \text{ in.}^2$

### Example 9.3

What is the design strength of the element of Example 9.1 for A36 steel?

### SOLUTION

1.  $A_g = 4.75 \text{ in.}^2$
2.  $A_e = 2.21 \text{ in.}^2$  (from Example 9.2)
3. From Equation 9.1
 
$$P_u = 0.9F_y A_g = 0.9(36)(4.75) = 153.9 \text{ k}$$
4. From Equation 9.2
 
$$P_u = 0.75F_u A_e = 0.75(58)(2.21) = 96.14 \text{ k} \leftarrow \text{Controls}$$

### BLOCK SHEAR STRENGTH

In certain connections, a *block* of material at the end of the member may tear out. In the single-angle member shown in Figure 9.7, the block shear failure may occur along plane abc. The shaded block will fail by shear along plane ab and tension in section bc.

Figure 9.8 shows a tensile plate connected to a gusset plate. In this case, the block shear failure could occur in both the gusset plate and the main tensile member. The tensile failure occurs along section bc and the shear failure along planes ab and cd.

A welded member shown in Figure 9.9 experiences block shear failure along welded planes abcd. It has a tensile area along bc and a shear area along ab and cd.

Both the tensile area and shear area contribute to the strength. The resistance to shear block will be the sum of the strengths of the two surfaces.

The resistance (strength) to shear block is given by a single two-part equation:

$$R_u = \phi R_n = \phi(0.6F_u A_{nv} + U_{bs} F_u A_{nt}) \leq \phi(0.6F_y A_{gv} + U_{bs} F_u A_{nt}) \tag{9.7}$$

where

$\phi$  is resistance factor, 0.75

$A_{nv}$  is net area subjected to shear

$A_{nt}$  is net area subjected to tension

$A_{gv}$  is gross area along the shear surface

$U_{bs}$  is 1.0 when the tensile stress is uniform (most cases)

$U_{bs}$  is 0.5 when the tensile is nonuniform

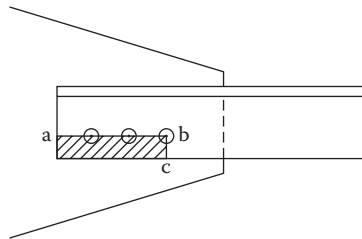


FIGURE 9.7 Block shear in a single angle member.

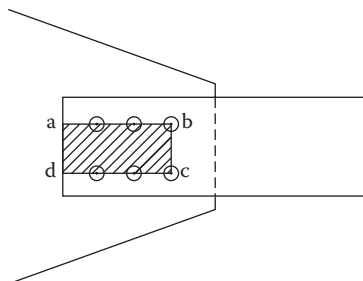


FIGURE 9.8 Block shear in a plate member.

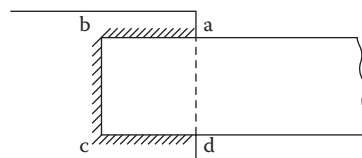


FIGURE 9.9 Block shear in a welded member.



**Example 9.4**

An  $L 6 \times 4 \times 1/2^*$  tensile member of A36 steel is connected by three  $7/8$  in. bolts, as shown in Figure 9.10. Determine the strength of the member.

**SOLUTION**

## I. Tensile strength of member

## A. Yielding in gross area

1.  $A_g = 4.75 \text{ in.}^2$
2.  $h = (7/8) + (1/8) = 1 \text{ in.}$
3. From Equation 9.1  
 $P_u = 0.9(36)(4.75) = 153.9 \text{ k}$

## B. Rupture in net area

1.  $A_n = A_g - \text{one hole area}$   
 $= 4.75 - (1)(1)(1/2) = 4.25 \text{ in.}^2$
2.  $U = 0.6$  for three bolts in a line
3.  $A_e = UA_n = 0.6(4.25) = 2.55 \text{ in.}^2$
4. From Equation 9.2  
 $P_u = 0.75(58)(2.55) = 110.9 \text{ k} \leftarrow \text{Controls}$

## II. Block shear strength

## A. Gross shear area along ab

$$A_{gv} = 10 \left( \frac{1}{2} \right) = 5 \text{ in.}^2$$

## B. Net shear area along ab

$$A_{nv} = A_{gv} - 2 \frac{1}{2} \text{ hole area}$$

$$= 5 - 2.5(1) \left( \frac{1}{2} \right) = 3.75 \text{ in.}^2$$

## C. Net tensile area along bc

$$A_{nt} = 2.5t - 1/2 \text{ hole}$$

$$= 2.5 \left( \frac{1}{2} \right) - \frac{1}{2} (1) \left( \frac{1}{2} \right) = 1.0 \text{ in.}^2$$

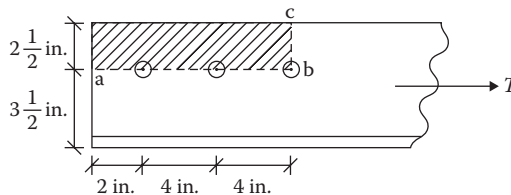
D.  $U_{bs} = 1.0$ 

## E. From Equation 9.7

$$\phi(0.6F_u A_{nv} + U_{bs} F_u A_{nt}) = 0.75[0.6(58)(3.75) + (1)(58)(1.0)] = 141.4 \text{ k}$$

$$\phi(0.6F_y A_{gv} + U_{bs} F_u A_{nt}) = 0.75[0.6(36)(5) + (1)(58)(1.0)] = 124.5 \text{ k}$$

The strength is 110.9 k controlled by rupture of the net section.



**FIGURE 9.10** The three-bolt connection of Example 9.4.

\* Section properties not included in the appendix.

## DESIGN PROCEDURE FOR TENSION MEMBERS

The type of connection used for a structure affects the choice of the tensile member. The bolt-type connections are convenient for members consisting of angles, channels, and W and S shapes. The welded connection suits plates, channels, and structural tees.

The procedure to design a tension member consists of the following:

1. Determine the critical combination(s) of factored loads.
2. For each critical load combination, determine the gross area required by Equation 9.1 and select a section.
3. Make provision for holes or welds based on the connection requirements, and determine the effective net area.
4. Compute the loading capacity of the effective net area of the selected section by Equation 9.2. This capacity should be more than the design load(s) of step 1. If it is not, revise the selection.
5. Check the block shear strength with Equation 9.5. If it is not adequate, either revise the connection or revise the member size.
6. The limitation of the maximum slenderness ratio of 300 is not mandatory in AISC 2010. However, it is still a preferred practice except for rods and hangers.

Although rigid frames are common in steel structures, roof trusses having nonrigid connections are used for industrial or mill buildings. The members in the bottom chord of a truss are commonly in tension. Some of the web members are in tension and the others are in compression. With changing of the wind direction, the forces in the web members alternate between tension and compression. Accordingly, the web members have to be designed to function both as tensile as well as compression elements.

### Example 9.5

A roof system consists of a Warren-type roof truss, as shown in Figure 9.11. The trusses are spaced 25 ft. apart. The following loads are passed on to the truss through the purlins. Design the bottom chord members consisting of the two angles section separated by a  $\frac{3}{8}$  in. gusset plate. Assume one line of two  $\frac{3}{4}$  in. diameter bolts spaced 3 in. at each joint. Use A572 steel.

Dead load (deck, roofing, insulation)	= 10 psf
Snow	= 29 psf
Roof LL	= 20 psf
Wind (vertical)	= 16 psf

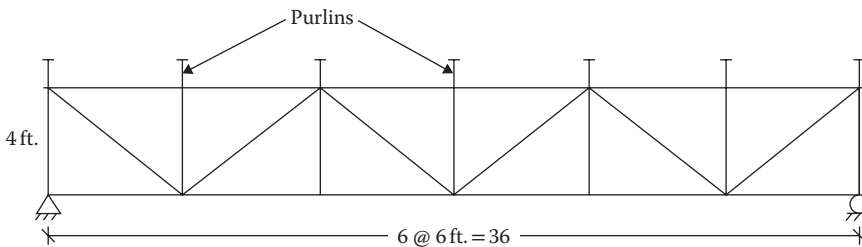


FIGURE 9.11 A Warren roof truss.

**SOLUTION**

A. Computation of loads

1. Adding 20% to dead load for the truss weight,  $D = 12$  psf.
2. Consider the following load combinations:
  - a.  $1.2D + 1.6(L_r \text{ or } S) + 0.5W = 1.2(12) + 1.6(29) + 0.5(16) = 68.8$  psf ← Controls
  - b.  $1.2D + W + 0.5(L_r \text{ or } S) = 1.2(12) + 16 + 0.5(29) = 44.9$  psf
3. Tributary area of an entire truss =  $36 \times 25 = 900$  ft.<sup>2</sup>
4. Total factored load on the truss =  $68.8 \times 900 = 61,920$  lb or 61.92 k.
5. This load is distributed through purlins in six parts, on to five interior joints and one-half on each end joint since the exterior joint tributary is one-half that of the interior joints. Thus, the joint loads are

$$\text{Interior joints} = \frac{61.92}{6} = 10.32 \text{ k}$$

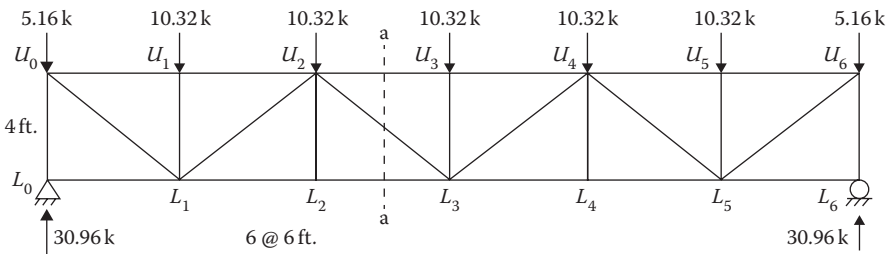
$$\text{Exterior joints} = \frac{10.32}{2} = 5.16 \text{ k}$$

B. Analysis of truss

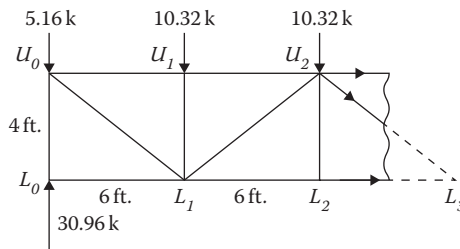
1. The loaded truss is shown in Figure 9.12.
2. Reaction @  $L_0$  and  $L_6 = 61.62/2 = 30.96$  k.
3. The bottom chord members  $L_2L_3$  and  $L_3L_4$  are subjected to the maximum force. A free-body diagram of the left of section a-a is shown in Figure 9.13.
4.  $M @ U_2 = 0$

$$-30.96(12) + 5.16(12) + 10.32(6) + F_{L_2L_3}(4) = 0$$

$$F_{L_2L_3} = 61.92 \text{ k} \leftarrow P_u$$



**FIGURE 9.12** Truss analysis for Example 9.5.



**FIGURE 9.13** Free-body diagram of truss.

## C. Design of member

1. From Equation 9.1

$$A_g = \frac{P_u}{0.9F_y} = \frac{61.92}{0.9(50)} = 1.38 \text{ in.}^2$$

Try  $2 \text{ L } 3 \times 2 \times 1/4$   $A_g = 2.4 \text{ in.}^2$ , centroid  $\bar{x} = 0.487$  (from Appendix C, Table C.3a through c).

- 2.
- $h = (3/4) + (1/8) = (7/8) \text{ in.}$

$$A_n = A_g - \text{one hole area}$$

$$= 2.40 - (1) \left( \frac{7}{8} \right) \left( \frac{1}{4} \right) = 2.18 \text{ in.}^2$$

3. From Equation 9.6
- $U = 1 - \frac{0.487}{3} = 0.84$

$$A_e = 0.84 (2.18) = 1.83 \text{ in.}^2$$

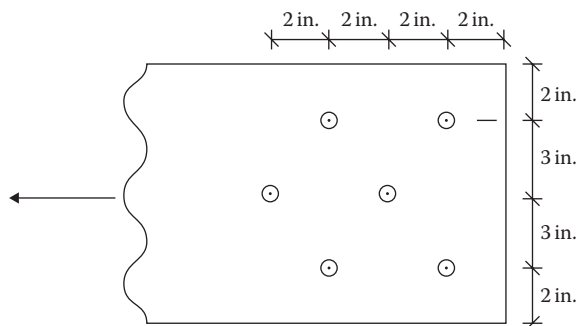
4. From Equation 9.2

$$\begin{aligned} P_u &= 0.75F_u A_e \\ &= 0.75(65)(1.83) = 89.27 \text{ k} > 61.92 \text{ k} \text{ OK} \end{aligned}$$

D. Check for block shear strength (similar to Example 9.4)

**PROBLEMS**

- 9.1** A  $1/2 \text{ in.} \times 10 \text{ in.}$  plate is attached to another plate by means of six  $3/4 \text{ in.}$  diameter bolts, as shown in Figure P9.1. Determine the net area of the plate.
- 9.2** A  $3/4 \text{ in.} \times 10 \text{ in.}$  plate is connected to a gusset plate by  $7/8 \text{ in.}$  diameter bolts, as shown in Figure P9.2. Determine the net area of the plate.
- 9.3** An  $\text{L } 5 \times 5 \times 1/2$  has staggered holes for  $3/4 \text{ in.}$  diameter bolts, as shown in Figure P9.3. Determine the net area for the angle ( $A_g = 4.79 \text{ in.}^2$ , centroid  $\bar{x} = 1.42 \text{ in.}$ ).
- 9.4** An  $\text{L } 8 \times 4 \times 1/2$  has staggered holes for  $7/8 \text{ in.}$  diameter bolts, as shown in Figure P9.4. Determine the net area ( $A_g = 5.80 \text{ in.}^2$ , centroid  $\bar{x} = 0.854 \text{ in.}$ ).

**FIGURE P9.1** Plate to plate connection.

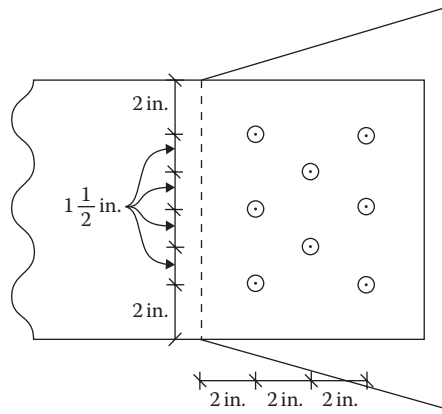


FIGURE P9.2 Plate to gusset plate connection.

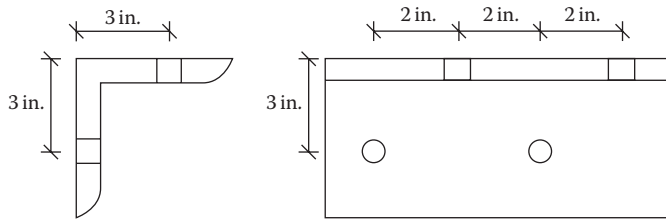


FIGURE P9.3 Staggered angle connection.

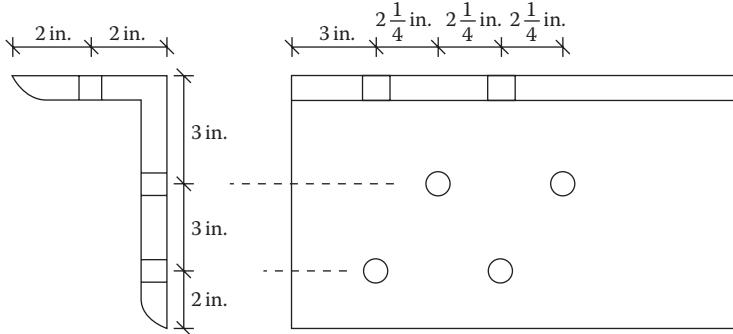


FIGURE P9.4 Staggered long leg angle connection.

- 9.5 A channel section C 9 × 20 has the bolt pattern shown in Figure P9.5. Determine the net area for 3/4 in. bolts.
- 9.6 Determine the effective net area for Problem 9.2.
- 9.7 Determine the effective net area for Problem 9.3.
- 9.8 Determine the effective net area for Problem 9.4.
- 9.9 Determine the effective net area for the connection shown in Figure P9.6 for an L 5 × 5 × 1/2.
- 9.10 For Problem 9.9 with welding in the transverse direction only, determine the effective net area.
- 9.11 Determine the tensile strength of the plate in Problem 9.1 for A36 steel.
- 9.12 A tensile member in Problem 9.4 is subjected to a dead load of 30 k and a live load of 60 k. Is the member adequate? Use A572 steel.

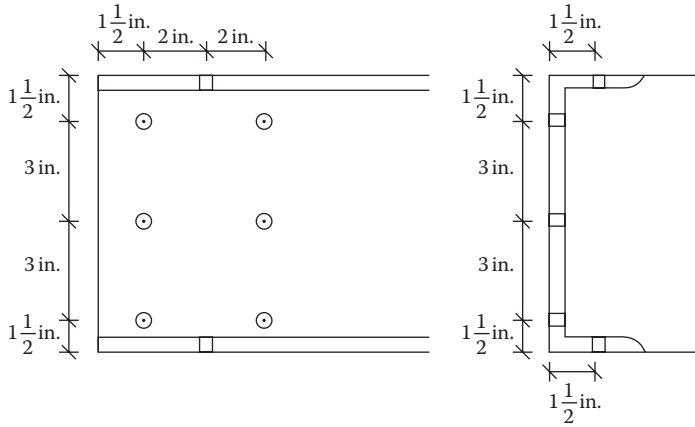


FIGURE P9.5 Staggered channel connection.

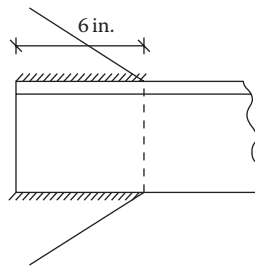


FIGURE P9.6 Welded connection.

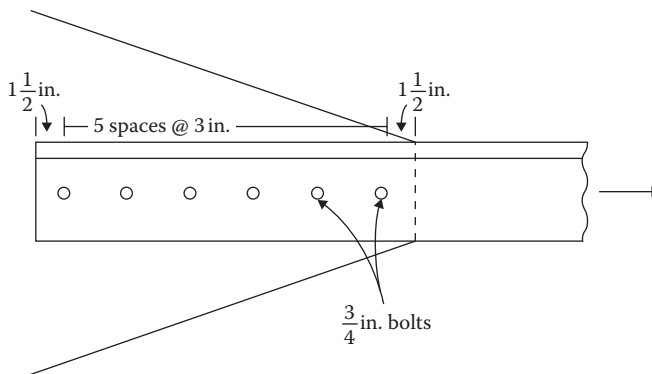


FIGURE P9.7 Connection for Problem 9.14.

9.13 Is the member in Problem 9.9 adequate to support the following loads all acting in tension?  
Use A992 steel.

- Dead load = 25 k
- Live load = 50 k
- Snow load = 40 k
- Wind load = 35 k

9.14 An angle of A36 steel is connected to a gusset plate with six 3/4 in. bolts, as shown in Figure P9.7. The member is subjected to a dead load of 25 k and a live load of 40 k. Design a 3 1/2 in. size (3 1/2 × ?) member.

- 9.15 An angle of A36 steel is connected by 7/8 in. bolts, as shown in Figure P9.8. It is exposed to a dead load of 20 k, a live load of 45 k, and a wind load of 36 k. Design a 4 in. size ( $4 \times ?$ ) member. Use A992 steel.
- 9.16 Compute the strength including the block shear capacity of a member comprising  $\angle 3\frac{1}{2} \times 3\frac{1}{2} \times \frac{1}{2}$  as shown in Figure P9.9. The bolts are 3/4 in. The steel is A36.
- 9.17 A tensile member comprises a W 12  $\times$  30 section of A36 steel, as shown in Figure P9.10 with each side of flanges having three holes for 7/8 in. bolts. Determine the strength of the member including the block shear strength.

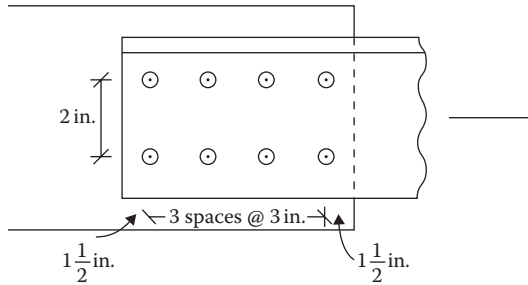


FIGURE P9.8 Two-row connection for Problem 9.15.

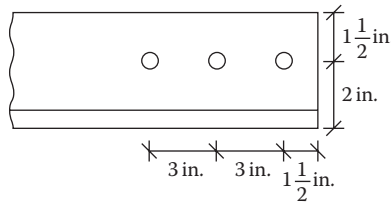


FIGURE P9.9 Tensile member for Problem 9.16.

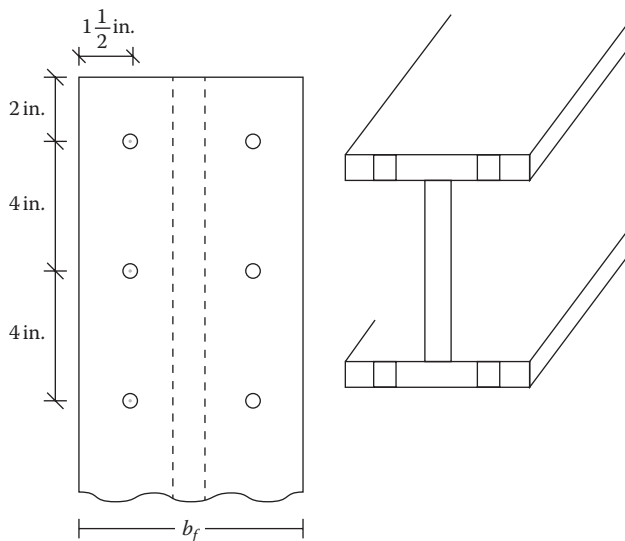
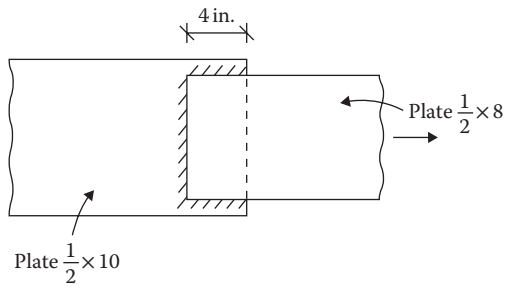


FIGURE P9.10 Wide flange tensile member for Problem 9.17.



**FIGURE P9.11** Welded member for Problem 9.18.

**9.18** Determine the strength of the welded member shown in Figure P9.11, including the block shear capacity. The steel is A572.



---

# 10 Compression Steel Members

## STRENGTH OF COMPRESSION MEMBERS OR COLUMNS

The basic strength requirement or compression in the load resistance factor design format is

$$P_u \leq \phi P_n \quad (10.1)$$

where

$P_u$  is factored axial load

$\phi = 0.9$ , resistance factor for compression

$P_n$  is nominal compressive strength of the column

For a compression member that fails by yielding,  $P_n = F_y A_g$ , similar to a tensile member. However, the steel columns are leaner; that is, the length dimension is much larger than the cross-sectional dimension. Accordingly, the compression capacity is more often controlled by the rigidity of the column against buckling instead of yielding. There are two common modes of failure in this respect.

1. *Local instability*: If the parts (elements) comprising a column are relatively very thin, a localized buckling or wrinkling of one or more of these elements may occur prior to the instability of the entire column. Based on the ratio of width to thickness of the element, a section is classified as a *slender* or a *nonslender* for the purpose of local instability.
2. *Overall instability*: Instead of an individual element getting wrinkled, the entire column may bend or buckle lengthwise under the action of the axial compression force. This can occur in three different ways.
  - a. *Flexural buckling*: A deflection occurs by bending about the weak axis, as shown in Figure 10.1. The slenderness ratio is a measure of the flexural buckling of a member. When the buckling occurs at a stress level within the proportionality limit of steel, it is called *elastic buckling*. When the stress at buckling is beyond the proportionality limit, it is *inelastic buckling*. The columns of any shape can fail in this mode by either elastic or inelastic buckling.
  - b. *Torsional buckling*: This type of failure is caused by the twisting of the member longitudinally, as shown in Figure 10.2. The doubly symmetric hot-rolled shapes like W, H, or round are normally not susceptible to this mode of buckling. The torsional buckling of doubly symmetric sections can occur only when the torsional unbraced length exceeds the lateral flexural unbraced length. The thinly built-up sections might be exposed to torsional buckling.
  - c. *Flexural-torsional buckling*: This failure occurs by the combination of flexural and torsional buckling when a member twists while bending, as shown in Figure 10.3. Only the sections with a single axis of symmetry or the nonsymmetric sections such as a channel, tee, and angle are subjected to this mode of buckling.

The nominal compressive strength,  $P_n$ , in Equation 10.1 is the lowest value obtained according to the limit states of flexural buckling, torsional buckling, and flexural-torsional buckling.

The flexural buckling limit state is applicable to all sections.

In addition, the doubly symmetric sections having torsional unbraced length larger than the weak-axis flexural unbraced length, the doubly symmetric sections built from thin plates, singly symmetric sections, and nonsymmetric sections are subjected to torsional buckling or flexural-torsional

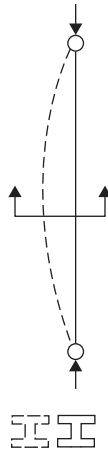


FIGURE 10.1 Flexural buckling.



FIGURE 10.2 Torsional buckling.

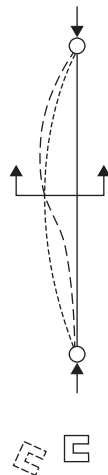


FIGURE 10.3 Flexural-torsional buckling.

buckling that requires substantive evaluations. It is desirable to prevent it when feasible. This can be done by bracing the member to prevent twisting.

The limit states are considered separately for the nonslender and the slender sections according to the local instability criteria.

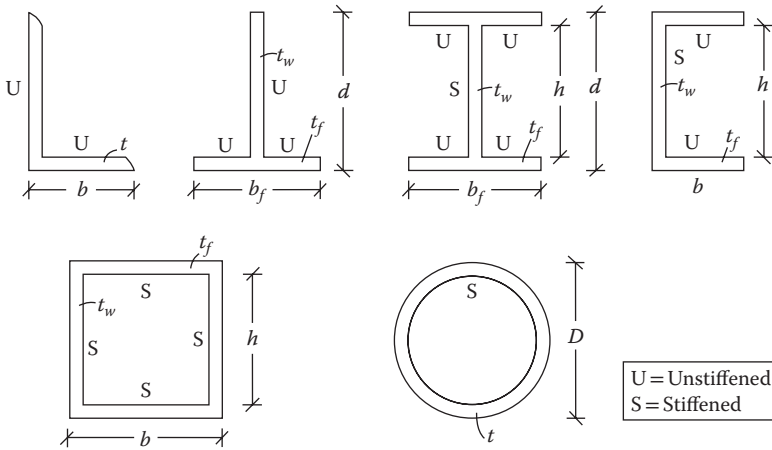
**LOCAL BUCKLING CRITERIA**

In the context of local buckling, the elements of a structural section are classified into following two categories:

1. *Unstiffened element*: This has an unsupported edge (end) parallel to (along) the direction of the load, like an angle section.
2. *Stiffened element*: This is supported along both of its edges, like the web of a wide flange section.

The two types of elements are illustrated in Figure 10.4.

When the ratio of width to thickness of an element of a section is greater than the specified limit  $\lambda_r$ , as shown in Table 10.1, it is classified as a slender shape. The cross section of a slender element is not fully effective in resisting a compressive force. Such elements should be avoided or else their



**FIGURE 10.4** Stiffened and unstiffened elements.

**TABLE 10.1**  
**Slenderness Limit for Compression Member**

Element	Width :		Magnitude for 36 ksi	Magnitude for 50 ksi
	Thickness Ratio	$\lambda_r$		
W, S, M, H	$b_f/2t_f$	$0.56\sqrt{E/F_y}$	15.89	13.49
	$h/t_w$	$1.49\sqrt{E/F_y}$	42.29	35.88
C	$b_f/t_f$	$0.56\sqrt{E/F_y}$	15.89	13.49
	$h/t_w$	$1.49\sqrt{E/F_y}$	42.29	35.88
T	$b_f/2t_f$	$0.56\sqrt{E/F_y}$	15.89	13.49
	$d/t_w$	$0.75\sqrt{E/F_y}$	21.29	18.16
Single L or double L with separation	$b/t$	$0.45\sqrt{E/F_y}$	12.77	10.84
Box, tubing	$b/t$	$1.4\sqrt{E/F_y}$	Box (46 ksi steel) 35.15	Tubing (42 ksi steel) 36.79
Circular	$D/t$	$0.11(E/F_y)$	Pipe (35 ksi steel) 91.14	

strength should be reduced, as discussed in the “Slender Compression Members” section. Separate provisions for strength reduction are made in the AISC manual for stiffened and unstiffened sections. The terms are explained in Figure 10.4.

## FLEXURAL BUCKLING CRITERIA

The term  $(KL/r)$ , known as the *slenderness ratio*, is important in column design. Not only does the compression capacity of a column depend on the slenderness ratio, but the ratio also sets a limit between the elastic and nonelastic buckling of the column. When the slenderness ratio exceeds a value of  $4.71\sqrt{E/F_y}$ , the column acts as an elastic column and the limiting (failure) stress level is within the elastic range.

According to the classic Euler formula, the critical load is inversely proportional to  $(KL/r)^2$ , where  $K$  is the effective length factor (coefficient), discussed in the “Effective Length Factor for Slenderness Ratio” section,  $L$  is the length of the column, and  $r$  is the radius of gyration given by  $\sqrt{I/A}$ .

Although it is not a mandatory requirement in the *AISC Manual 2010*, the AISC recommends that the slenderness ratio for a column should not exceed a value of 200.

## EFFECTIVE LENGTH FACTOR FOR SLENDERNESS RATIO

The original flexural buckling or Euler formulation considered the column pinned at both ends. The term  $K$  was introduced to account for the other end conditions because the end condition will make a column buckle differently. For example, if a column is fixed at both ends, it will buckle at the points of inflection about  $L/4$  distance away from the ends, with an effective length of one-half of the column length. Thus, the effective length of a column is the distance at which the column is assumed to buckle in the shape of an elastic curve. The length between the supports,  $L$ , is multiplied by a factor to calculate the effective length.

When columns are part of a frame, they are constrained at the ends by their connection to beams and to other columns. The effective length factor for such columns is evaluated by the use of the alignment charts or nomographs given in Figures 10.5 and 10.6; the former is for the braced frames where the sidesway is prevented, and the latter is for the moment frames where the sidesway is permitted.

In the nomographs, the subscripts A and B refer to two ends of a column for which  $K$  is desired. The term  $G$  is the ratio of the column stiffness to the girder stiffness expressed as

$$G = \frac{\sum I_c/L_c}{\sum I_g/L_g} \quad (10.2)$$

where

$I_c$  is moment of inertia of the column section

$L_c$  is length of the column

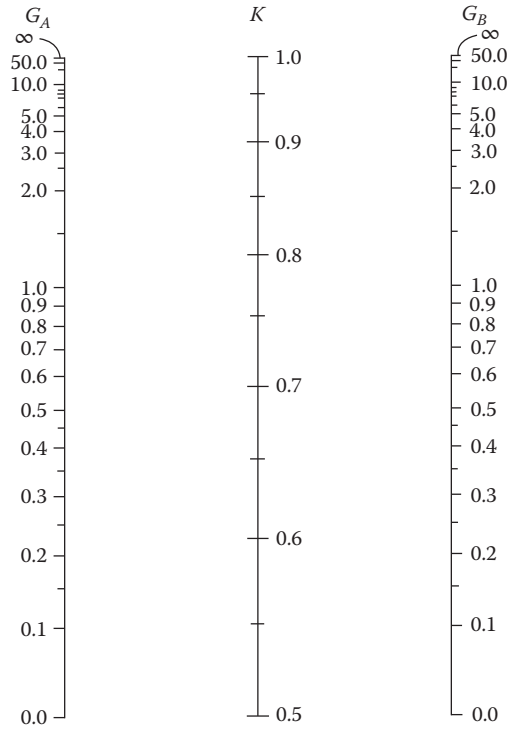
$I_g$  is moment of inertia of the girder beam meeting the column

$L_g$  is length of the girder

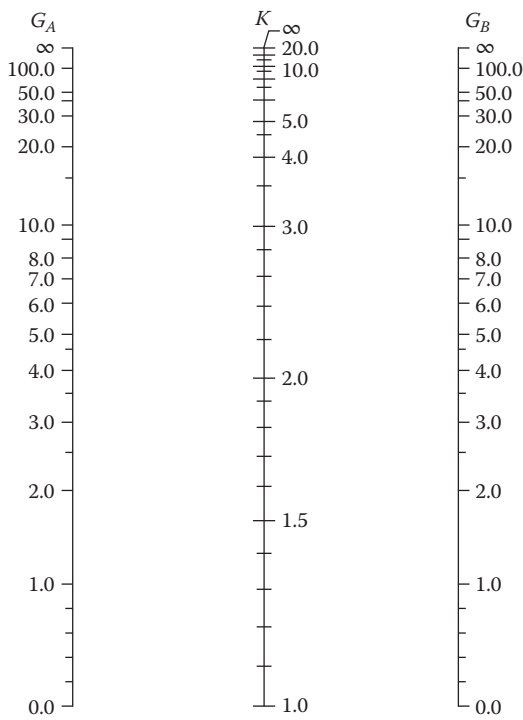
$\sum$  is summation of all members meeting at joint A for  $G_A$  and at joint B for  $G_B$

The values of  $I_c$  and  $I_g$  are taken about the axis of bending of the frame. For a column base connected to the footing by a hinge,  $G$  is taken as 10 and when the column is connected rigidly (fixed) to the base,  $G$  is taken as 1.

After determining  $G_A$  and  $G_B$  for a column,  $K$  is obtained by connecting a straight line between points  $G_A$  and  $G_B$  on the nomograph. Since the values of  $I$  (moment of inertia) of the columns and



**FIGURE 10.5** Alignment chart, sidesway prevented. (Courtesy of American Institute of Steel Construction, Chicago, IL.)



**FIGURE 10.6** Alignment chart, sidesway not prevented. (Courtesy of American Institute of Steel Construction, Chicago, IL.)

beams at the joint are required to determine  $G$ , the factor  $K$  cannot be determined unless the size of the columns and the beams are known. On the other hand, the factor  $K$  is required to determine the column size. Thus, these nomographs need some preliminary assessments of the value of  $K$  and the dimensions of the columns and girders.

One of the conditions for the use of the nomographs or the alignment charts is that all columns should buckle elastically, that is,  $KL > 4.71 \sqrt{E/F_y}$ . If a column buckles inelastically, a stiffness reduction factor,  $\tau_a$ , has to be applied. The factor  $\tau_a$  is the ratio of the tangent modulus of elasticity to the modulus of elasticity of steel. The value has been tabulated in the AISC manual as a function of  $P_u/A_g$ . Without  $\tau_a$ , the value of  $K$  is on the conservative side.

However, in lieu of applying the monographs in a simplified method, the factors (coefficients) listed in Figure 7.6 are used to ascertain the effective length. Figure 7.6 is used for isolated columns also. When Figure 7.6 is used for the unbraced frame columns, the lowest story (base) columns could be approximated by the condition with  $K = 2$  for the hinged base and  $K = 1.2$  for the fixed base, and the upper story columns are approximated by the condition with  $K = 1.2$ . For braced frames, the condition with  $K = 0.65$  is a good approximation.

**Example 10.1**

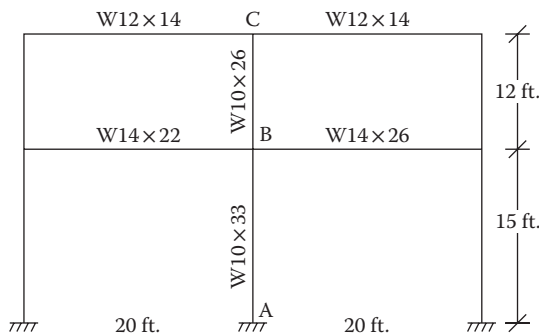
A rigid unbraced moment frame is shown in Figure 10.7. Determine the effective length factors with respect to weak axis for members AB and BC.

**SOLUTION**

1. The section properties and  $G$  ratios are arranged in the table below:

Joint	Column				Girder				G
	Section	$I$ (in. <sup>4</sup> )	$L$ (ft.)	$I/L$	Section	$I$ (in. <sup>4</sup> )	$L$ (ft.)	$I/L$	
A	Fixed								1
B	W10 × 33	171	15	11.40 <sup>a</sup>	W14 × 22	199	20	9.95	23.4/22.20 = 1.05
	W10 × 26	144	12	12.00	W14 × 26	245	20	12.25	
	Σ			23.40				22.20	
C	W10 × 26	144	12	12.00	W12 × 14	88.6	20	4.43	12.00/8.86 = 1.35
					W12 × 14	88.6	20	4.43	
	Σ			12.00				8.86	

<sup>a</sup> Mixed units ( $I$  in in.<sup>4</sup> and  $L$  in ft.) can be used since the ratio is being used.



**FIGURE 10.7** An unbraced frame.

2. Column AB  
From Figure 10.6, the alignment chart for an unbraced frame (sideway permitted) connecting a line from  $G_A = 1$  to  $G_B = 1.05$ ,  $K = 1.3$ .
3. Column BC  
From the alignment chart with  $G_A = 1.05$  (point B) and  $G_B = 1.35$  (point C),  $K = 1.38$ .

### LIMIT STATES FOR COMPRESSION DESIGN

The limit states of design of a compression member depends on the category to which the compression member belongs, as described in the “Strength of Compression Members or Columns” section. The limit states applicable to different categories of columns are summarized in Table 10.2.

AISC 360-10 has organized the provisions for compression members as follows:

1. Flexural buckling of nonslender members
2. Torsional buckling and flexural-torsional buckling of nonslender members
3. Single-angle members
4. Built-up members by combining two shapes
5. Slender members

The discussion below follows the same order.

### NONSLENDER MEMBERS

#### FLEXURAL BUCKLING OF NONSLENDER MEMBERS IN ELASTIC AND INELASTIC REGIONS

Based on the limit state for flexural buckling, the nominal compressive strength  $P_n$  is given by

$$P_n = F_{cr} A_g \tag{10.3}$$

**TABLE 10.2**  
**Applicable Limit States for Compressive Strength**

Type of Column	Local Buckling (Local Instability)	
	Nonslender Column, $\lambda \leq \lambda_r$	Slender Column, $\lambda > \lambda_r$
<b>Overall Instability</b>		
1. Doubly symmetric members	Flexural buckling in elastic or inelastic region	Flexural buckling in elastic or inelastic region incorporating the reduction factors for slender element
2. Doubly symmetric thin plate builtup members or large unbraced torsional length members	Lowest of the following two limits: 1. Flexural buckling in elastic or inelastic region 2. Torsional buckling	Lowest of the following two limits, incorporating the reduction factors for slender element: 1. Flexural buckling in elastic or inelastic region 2. Torsional buckling
3. Singly symmetric or nonsymmetric members	Lowest of the following three limits: 1. Flexural buckling in elastic or inelastic region 2. Flexural-torsional buckling	Lowest of the following three limits, incorporating the reduction factors for slender element: 1. Flexural buckling in elastic or inelastic region 2. Flexural-torsional buckling

where

$F_{cr}$  is flexural buckling state (stress)

$A_g$  is gross cross-sectional area

Including the nominal strength in Equation 10.1, the strength requirement of a column can be expressed as

$$P_u = \phi F_{cr} A_g \quad (10.4)$$

The flexural buckling stress,  $F_{cr}$  is determined as follows.

### INELASTIC BUCKLING

When  $KL/r \leq 4.71\sqrt{E/F_y}$ , we have inelastic buckling, for which

$$F_{cr} = (0.658^{F_y/F_e}) F_y \quad (10.5)$$

where  $F_e$  is elastic critical buckling or Euler stress calculated according to Equation 10.6:

$$F_e = \frac{\pi^2 E}{(KL/r)^2} \quad (10.6)$$

### ELASTIC BUCKLING

When  $KL/r > 4.71\sqrt{E/F_y}$ , we have elastic buckling, for which

$$F_{cr} = 0.877 F_e \quad (10.7)$$

The value of  $4.71\sqrt{E/F_y}$ , at the threshold of inelastic and elastic buckling, is given in Table 10.3 for various types of steel.

The available critical stress  $\phi F_{cr}$  in Equation 10.4 for both the inelastic and elastic regions is given in Table 10.4 in terms of  $KL/r$ , adapted from the *AISC Manual 2010*.

### TORSIONAL AND FLEXURAL–TORSIONAL BUCKLING OF NONSLENDER MEMBERS

According to the commentary in Section E of AISC 360-10, in the design with hot-rolled column sections, the torsional buckling of symmetric shapes and the flexural-torsional buckling of nonsymmetric shapes are the failure modes that are not usually considered in design. They usually do not govern or the critical load differs very little from the flexural buckling mode.

Hence, this section usually applies to double-angle, tee-shaped, and other built-up members.

---

**TABLE 10.3**  
**Numerical Limits of**  
**Inelastic–Elastic Buckling**

Type of Steel	$4.71\sqrt{E/F_y}$
A36	133.7
A992	113.43
A572	113.43

---



**TABLE 10.4**  
**Available Critical Stress  $\phi F_{cr}$  for Compression Members ( $F_y = 50$  ksi and  $\phi = 0.90$ )**

$KL/r$	$\phi F_{cr}$ , ksi	$KL/r$	$\phi F_{cr}$ , ksi	$KL/r$	$\phi F_{cr}$ , ksi	$KL/r$	$\phi F_{cr}$ , ksi	$KL/r$	$\phi F_{cr}$ , ksi
1	45.0	41	39.8	81	27.9	121	15.4	161	8.72
2	45.0	42	39.5	82	27.5	122	15.2	162	8.61
3	45.0	43	39.3	83	27.2	123	14.9	163	8.50
4	44.9	44	39.1	84	26.9	124	14.7	164	8.40
5	44.9	45	38.8	85	26.5	125	14.5	165	8.30
6	44.9	46	38.5	86	26.2	126	14.2	166	8.20
7	44.8	47	38.3	87	25.9	127	14.0	167	8.10
8	44.8	48	38.0	88	25.5	128	13.8	168	8.00
9	44.7	49	37.7	89	25.2	129	13.6	169	7.89
10	44.7	50	37.5	90	24.9	130	13.4	170	7.82
11	44.6	51	37.2	91	24.6	131	13.2	171	7.73
12	44.5	52	36.9	92	24.2	132	13.0	172	7.64
13	44.4	53	36.7	93	23.9	133	12.8	173	7.55
14	44.4	54	36.4	94	23.6	134	12.6	174	7.46
15	44.3	55	36.1	95	23.3	135	12.4	175	7.38
16	44.2	56	35.8	96	22.9	136	12.2	176	7.29
17	44.1	57	35.5	97	22.6	137	12.0	177	7.21
18	43.9	58	35.2	98	22.3	138	11.9	178	7.13
19	43.8	59	34.9	99	22.0	139	11.7	179	7.05
20	43.7	60	34.6	100	21.7	140	11.5	180	6.97
21	43.6	61	34.3	101	21.3	141	11.4	181	6.90
22	43.4	62	34.0	102	21.0	142	11.2	182	6.82
23	43.3	63	33.7	103	20.7	143	11.0	183	6.75
24	43.1	64	33.4	104	20.4	144	10.9	184	6.67
25	43.0	65	33.0	105	20.1	145	10.7	185	6.60
26	42.8	66	32.7	106	19.8	146	10.6	186	6.53
27	42.7	67	32.4	107	19.5	147	10.5	187	6.46
28	42.5	68	32.1	108	19.2	148	10.3	188	6.39
29	42.3	69	31.8	109	18.9	149	10.2	189	6.32
30	42.1	70	31.4	110	18.6	150	10.0	190	6.26
31	41.9	71	31.1	111	18.3	151	9.91	191	6.19
32	41.8	72	30.8	112	18.0	152	9.78	192	6.13
33	41.6	73	30.5	113	17.7	153	9.65	193	6.06
34	41.4	74	30.2	114	17.4	154	9.53	194	6.00
35	41.2	75	29.8	115	17.1	155	9.40	195	5.94
36	40.9	76	29.5	116	16.8	156	9.28	196	5.88
37	40.7	77	29.2	117	16.5	157	9.17	197	5.82
38	40.5	78	28.8	118	16.2	158	9.05	198	5.76
39	40.3	79	28.5	119	16.0	159	8.94	199	5.70
40	40.0	80	28.2	120	15.7	160	8.82	200	5.65

Source: Courtesy of American Institute of Steel Construction, Chicago, Illinois.

The nominal strength is governed by Equation 10.3. Also, the  $F_{cr}$  value is determined according to Equation 10.5 or 10.7 except for two-angle and tee-shaped members. For two-angle and tee-shaped section,  $F_{cr}$  is determined directly by a different type of equation. For simplicity, Equation 10.5 or 10.7 can be used with  $y$  axis strength.

However, to determine the Euler stress  $F_e$ , instead of Equation 10.6, a different set of formulas is used that includes the warping and torsional constants for the section.

## SINGLE-ANGLE MEMBERS

For single angles with  $b/t \leq 20$ , only the flexural limit state is to be considered. This applies to all currently produced hot-rolled angles. Thus, the flexural–torsional limit state applies only to fabricated angles with  $b/t > 20$ , for which the provisions of the “Torsional and Flexural–Torsional Buckling of Nonslender Members” section apply.

AISC provides a simplified approach in which load is applied through one connected leg. The slenderness ratio is computed by a specified equation. Then, Equations 10.4 through 10.7 are used to determine the capacity.

## BUILT-UP MEMBERS

The members are made by interconnecting elements by bolts or welding. The empirical relations for the effective slenderness ratio for the composite section is used to consider the built-up member acting as a single unit. Depending on the shape of the section, it is designed according to the flexural buckling or flexural-torsional buckling.

## SLENDER COMPRESSION MEMBERS

The approach to design slender members having  $\lambda > \lambda_r$  is similar to the nonslender members in all categories except that a slenderness reduction factor,  $Q$ , is included in the expression  $4.7\sqrt{E/F_y}$  to classify the inelastic and elastic regions and  $Q$  is also included in the equations for  $F_{cr}$ . The slenderness reduction factor  $Q$  has two components:  $Q_s$  for the slender unstiffened elements and  $Q_a$  for the slender stiffened elements. These are given by a set of formulas for different shapes of columns. A reference is made to the Section E7 of Chapter 16 of the AISC manual 2010.

All W shapes have nonslender flanges for A992 steel. All W shapes listed for the columns in the AISC manual have nonslender webs (except for W14  $\times$  43). However, many W shapes meant to be used as beams have slender webs in the compression.

This chapter considers only the doubly symmetric nonslender members covered in the “Nonslender Members” section. By proper selection of a section, this condition, that is,  $\lambda \leq \lambda_r$  could be satisfied.

## USE OF THE COMPRESSION TABLES

Section 4 of the *AISC Manual 2010* contains tables concerning “available strength in axial compression, in kips” for various shapes and sizes. These tables directly give the capacity as a function of effective length ( $KL$ ) with respect to least radius of gyration for various sections. The design of columns is a direct procedure from these tables. An abridged table for  $F_y = 50$  ksi is given in Appendix C, Table C.8.

When the values of  $K$  and/or  $L$  are different in the two directions, both  $K_x L_x$  and  $K_y L_y$  are computed. If  $K_x L_x$  is bigger, it is adjusted as  $K_x L_x / (r_x / r_y)$ . The higher of the adjusted  $K_x L_x / (r_x / r_y)$  and  $K_y L_y$  value is entered in the table to pick a section that matches the factored design load  $P_u$ .

When designing for a case when  $K_x L_x$  is bigger, the adjustment of  $K_x L_x / (r_x / r_y)$  is not straightforward because the values of  $r_x$  and  $r_y$  are not known. The initial selection could be made based on the  $K_y L_y$  value and then the adjusted value of  $K_x L_x / (r_x / r_y)$  is determined based on the initially selected section.

**Example 10.2**

A 25-ft.- long column has one end rigidly fixed to the foundation. The other end is braced (fixed) in the weak axis and free to translate in the strong axis. It is subjected to a dead load of 120 k and a live load of 220 k. Design the column using A992 steel.

**SOLUTION**

A. Analytical solution

1. Assume a dead load of 100 lbs/ft.  
Weight of column = 25(0.1) = 2.5 k
2. Factored design load  
 $P_u = 1.2(120 + 2.5) + 1.6(220) = 499$  k
3. For yield limit state

$$A_g = \frac{P_u}{\phi F_y} = \frac{499}{0.9(50)} = 11.1 \text{ in.}^2$$

4. The size will be much larger than step 3 to allow for the buckling mode of failure  
Select a section W14 × 61A = 17.9 in.<sup>2</sup>

$$r_x = 5.98 \text{ in.}$$

$$r_y = 2.45 \text{ in.}$$

$$\frac{b_f}{2t_f} = 7.75$$

$$\frac{h}{t_w} = 30.4$$

$$0.56 \sqrt{\frac{E}{F_y}} = 0.56 \sqrt{\frac{29,000}{50}} = 13.49$$

$$1.49 \sqrt{\frac{E}{F_y}} = 1.49 \sqrt{\frac{29,000}{50}} = 35.88$$

5. Since  $b_f/2t_f < 0.56\sqrt{E/F_y}$  and  $h/t_w < 1.49\sqrt{E/F_y}$ , it is a nonslender section
6.  $K_x = 1.2$  from Figure 7.6

$$K_y = 0.65$$

$$\frac{K_x L_x}{r_x} = \frac{1.2(25 \times 12)}{5.98} = 60.2$$

$$\frac{K_y L_y}{r_y} = \frac{0.65(25 \times 12)}{2.45} = 79.59 \leftarrow \text{Controls}$$

Since 79.59 < 200 **OK**

7. From Table 10.3,  $4.71\sqrt{E/F_y} = 113.43$   
Since 79.59 < 113.43, inelastic buckling

$$F_e = \frac{\pi^2 E}{(KL/r)^2} = \frac{\pi^2(29,000)}{(79.59)^2} = 45.14 \text{ ksi}$$

$$9. F_{cr} = (0.658^{50/45.14})50 = 31.45 \text{ ksi}$$

10.  $\phi P_n = (0.9)(31.45)(17.9) = 507$  k **OK**

B. Use of Appendix C, Table C.8

1.  $K_x L_x = 1.2(25) = 30$  ft.

$$K_y L_y = 0.65(25) = 16.25 \text{ ft.}$$

2. Select preliminary section

Based on  $K_y L_y = 16.25$  ft., section W14 × 61, capacity = 507 k (interpolated), from Appendix C, Table C.8

3. For section W14 × 61,  $r_x = 5.98$  in.,  $r_y = 2.45$  in.

$$\text{Adjusted } \frac{K_x L_x}{r_x / r_y} = \frac{1.2(25)}{5.98/2.45} = 12.29$$

Use the larger value of  $K_y L_y$  of 16.25 ft.

4. Section from Appendix C, Table C.8 W14 × 61 with capacity = 507 k

### Example 10.3

An unbraced hinged at base column as shown in Figure 10.8 is fabricated from Grade 50 steel. Determine the limit state that will control the design of the column.

### SOLUTION

1. The doubly symmetric built-up section will be subjected to flexural-torsional buckling.

$$2. \frac{b}{t} = \frac{10}{0.25} = 40$$

$$1.4 \sqrt{\frac{E}{F_y}} = 1.4 \sqrt{\frac{29,000}{50}} = 33.72$$

Since  $40 > 33.72$ , it is a slender column; the reduction factors have to be applied.

$$3. I = I_{\text{out}} - I_{\text{inside}} \\ = \frac{1}{12}(10)(10)^3 - \frac{1}{12}(9.5)(9.5)^3 \\ = 154.58 \text{ in.}^4$$

$$A = (10)(10) - (9.5)(9.5) \\ = 9.75 \text{ in.}^2$$

$$r = \sqrt{\frac{I}{A}} = \sqrt{\frac{154.58}{9.75}} = 3.98 \text{ in.}$$

$$K = 2.0$$

$$\frac{KL}{r} = \frac{2.0(20 \times 12)}{3.98} = 120.6$$

$$4. \text{ From Table 10.2, } 4.71 \sqrt{\frac{E}{F_y}} = 113.43$$

$$\frac{KL}{r} > 4.71 \sqrt{\frac{E}{F_y}}, \text{ elastic flexural buckling}$$

5. The lowest of the following two limit states will control:
- Elastic flexural buckling with the slender reduction factors
  - Torsional buckling with the slender reduction factors

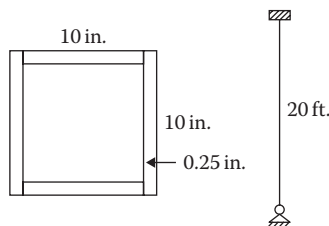
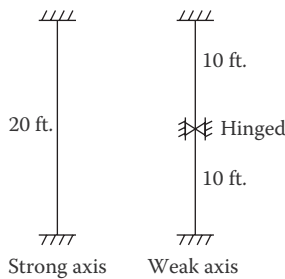


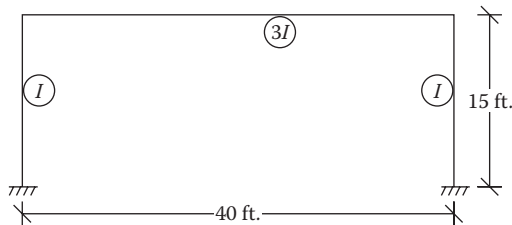
FIGURE 10.8 Built-up column.

**PROBLEMS**

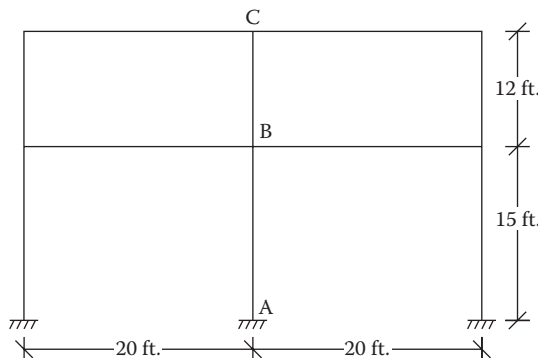
- 10.1 A  $W8 \times 31$  column of A36 steel is 20 ft. long. Along the  $y$  axis, it is hinged at both ends. Along the  $x$  axis, it is hinged at one end and free to translate at the other end. In which direction is it likely to buckle? ( $r_x = 3.47$  in.,  $r_y = 2.02$  in.)
- 10.2 An HSS  $5 \times 2\frac{1}{2} \times 1/4$  braced column is supported, as shown in Figure P10.1. Determine the controlling (higher) slenderness ratio.
- 10.3 A single-story single-bay frame has the relative  $I$  values shown in Figure P10.2. Determine the effective length of the columns along the  $x$  axis. Sway is permitted in  $x$  direction.
- 10.4 The frame of Figure P10.3 is braced and bends about the  $x$  axis. All beams are  $W18 \times 35$ , and all columns are  $W10 \times 54$ . Determine the effective length factors for AB and BC.
- 10.5 An unbraced frame of Figure P10.4 bends along the  $x$  axis. Determine the effective length factors for AB and BC.
- 10.6 Determine the effective length factors for AB and BC of the frame of Figure P10.4 for bending along the  $y$  axis. Whether the factors determined in Problem 10.5 or the factors determined in Problem 10.6 will control the design?



**FIGURE P10.1** An HSS column.



**FIGURE P10.2** Frame for Problem 10.3.



**FIGURE P10.3** Frame for Problem 10.4.

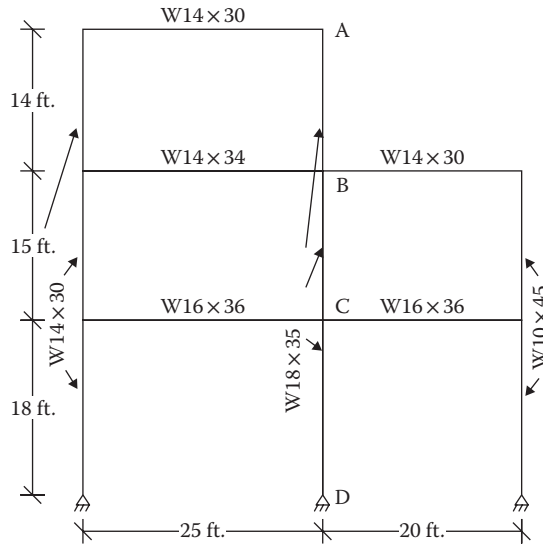


FIGURE P10.4 Frame for Problem 10.5.

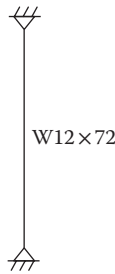


FIGURE P10.5 Column for Problem 10.7.

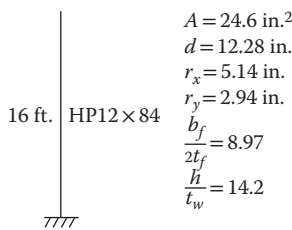


FIGURE P10.6 Column for Problem 10.8.

- 10.7 Determine the strength of the column of A992 steel in Figure P10.5, when (a) the length is 15 ft. and (b) the length is 30 ft.
- 10.8 Compute the strength of the member of A36 steel shown in Figure P10.6.
- 10.9 Compute the strength of the member (translation permitted) shown in Figure P10.7 of A500 Grade B steel.
- 10.10 A W18 × 130 section is used as a column with one end pinned and the other end fixed against rotation but is free to translate. The length is 12 ft. Determine the strength of the A992 steel column.
- 10.11 Determine the maximum dead and live loads that can be supported by the compression member shown in Figure P10.8. The live load is twice the dead load.

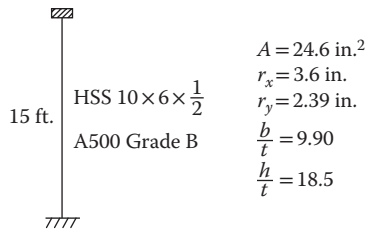


FIGURE P10.7 Column for Problem 10.9.

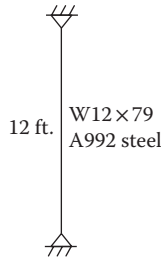


FIGURE P10.8 Column for Problem 10.11.

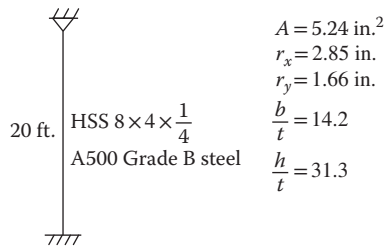


FIGURE P10.9 Column for Problem 10.12.

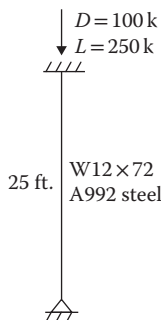


FIGURE P10.10 Column for Problem 10.13.

- 10.12 Determine the maximum dead and live loads supported by the braced column of Figure P10.9. The live load is one-and-a-half times the dead load.
- 10.13 Determine whether the braced member of A992 steel in Figure P10.10 is adequate to support the loads as indicated.
- 10.14 Check whether the A36 steel member of Figure P10.11 unbraced at the top is adequate for the indicated loads.
- 10.15 An HSS  $6 \times 4 \times 5/16$  braced section (46 ksi steel) shown in Figure P10.12 is applied by a dead load of 40 k and a live load of 50 k. Check the column adequacy.

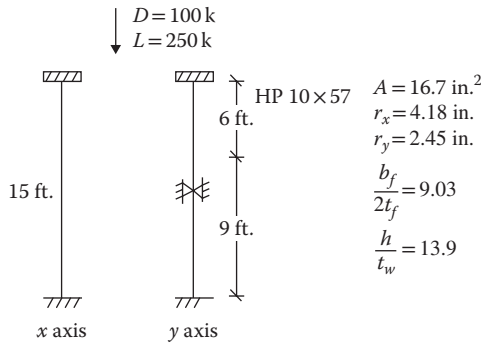


FIGURE P10.11 Column for Problem 10.14.

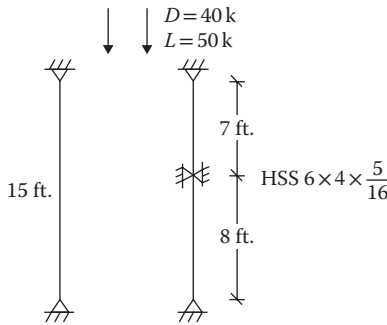


FIGURE P10.12 Column for Problem 10.15.

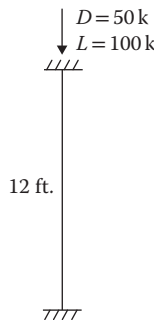


FIGURE P10.13 Column for Problem 10.16.

- 10.16 Select an HSS section for the braced column shown in Figure P10.13.
- 10.17 Design a standard pipe section of A53 Grade B steel for the braced column shown in Figure P10.14.
- 10.18 Select a W14 shape of A992 steel for the braced column of 25 ft. length shown in Figure P10.15. Both ends are fixed. There are bracings at 10 ft. from top and bottom in the weaker direction.
- 10.19 Design a W14 section column AB of the frame shown in Figure P10.16. It is unbraced along the *x* axis and braced in the weak direction. The loads on the column are dead load = 200 k and live load = 600 k. First determine the effective length factor using Figure 7.6. After selecting the preliminary section for column AB, use the alignment chart with the same size for column BC as of column AB to revise the selection. Use W16 × 100 for the beam sections meeting at B.



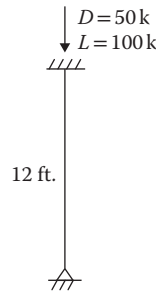


FIGURE P10.14 Column for Problem 10.17.

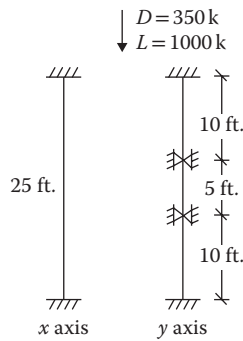


FIGURE P10.15 Column for Problem 10.18.

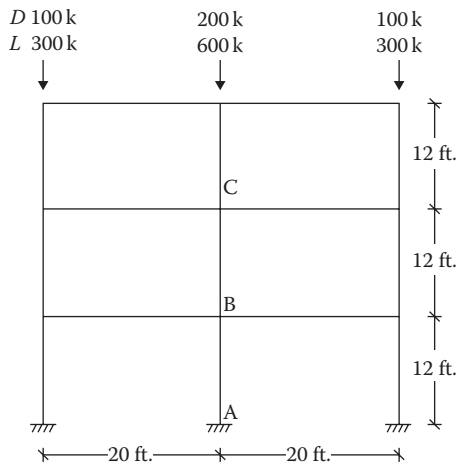


FIGURE P10.16 Frame for Problem 10.19.

- 10.20 Design the column AB in Problem 10.19 for the frame braced in both directions.
- 10.21 A WT12 × 34 column of 18 ft. length is pinned at both ends. Show what limiting states will determine the strength of the column. Use A992 steel. [ $A = 10 \text{ in.}^2$ ,  $r_y = 1.87 \text{ in.}$ ,  $b_f/2t_f = 7.66$ ,  $d/t_w = 28.7$ ]
- 10.22 The A572 braced steel column in Figure P10.17 is fixed at one end and hinged at the other end. Indicate the limit states that will control the strength of the column.
- 10.23 A double-angle braced section with a separation  $3/8 \text{ in.}$  is subjected to the loads shown in Figure P10.18. Determine the limit states that will govern the design of the column. Use Grade 50 steel. [ $A = 3.86 \text{ in.}^2$ ,  $r_y = 1.78 \text{ in.}$ ,  $b/t = 16$ ]

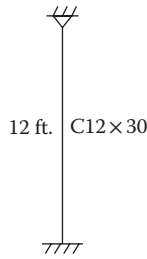


FIGURE P10.17 Column for Problem 10.22.

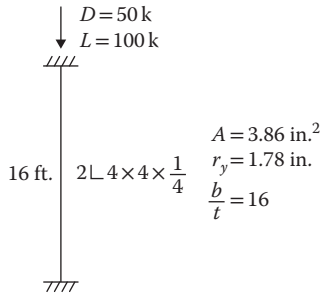


FIGURE P10.18 Column for Problem 10.23.

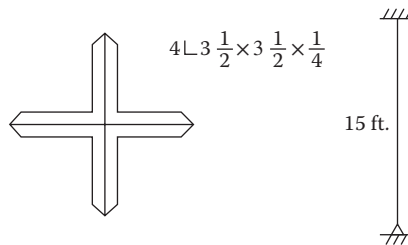


FIGURE P10.19 Cruciform column for Problem 10.24.

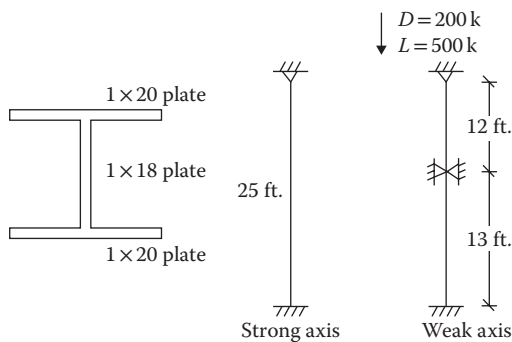


FIGURE P10.20 Built-up column for Problem 10.25.

**10.24** A cruciform column is fabricated from Grade 50 steel, as shown in Figure P10.19. Determine the limit states that will control the design. [Use the properties of a single angle to determine the values of the composite section.]

**10.25** For the braced column section and the loading shown in Figure P10.20, determine the limit states for which the column should be designed. Use A992 steel.

---

# 11 Flexural Steel Members

## BASIS OF DESIGN

Beams are the structural members that support transverse loads on them and are subjected to flexure and shear. An I shape is a common cross section for a steel beam where the material in the flanges at the top and bottom is most effective in resisting bending moment and the web provides for most of the shear resistance. As discussed in the “Design of Beams” section of Chapter 7—context of wood beams—the design process involves selection of a beam section on the basis of the maximum bending moment to be resisted. The selection is, then, checked for shear capacity. In addition, the serviceability requirement imposes the deflection criteria for which the selected section should be checked.

The basis of design for bending or flexure is as follows:

$$M_u \leq \phi M_n \quad (11.1)$$

where

- $M_u$  is factored design (imposed) moment
- $\phi$  is resistance factor for bending = 0.9
- $M_n$  is nominal moment strength of steel

## NOMINAL STRENGTH OF STEEL IN FLEXURE

Steel is a ductile material. As discussed in the “Elastic and Plastic Designs” section in Chapter 1, steel can acquire the plastic moment capacity  $M_p$ , wherein the stress distribution above and below the neutral axis will be represented by the rectangular blocks corresponding to the yield strength of steel, that is,  $M_p = F_y Z$ ,  $Z$  being the plastic moment of inertia of the section.

However, there are certain other factors that undermine the plastic moment capacity. One such factor relates to the unsupported (unbraced) length of the beam, and another relates to the slender dimensions of the beam section. The design capacity is determined considering both of these. The effect of the unsupported length on strength is discussed first in the “Lateral Unsupported Length” section. The beam’s slender dimensions affect the strength similar to the local instability of compression members. This is described in the “Noncompact and Slender Beam Sections for Flexure” section.

## LATERAL UNSUPPORTED LENGTH

As a beam bends, it develops compression stress in one part and tensile stress in the other part of its cross section. The compression region acts analogous to a column. If the entire member is slender, it will buckle outward similar to a column. However, in this case the compression portion is restrained by the tensile portion. As a result, a twist will occur in the section. This form of instability, as shown in Figure 11.1, is called *lateral torsional buckling*.

Lateral torsional buckling can be prevented in two ways:

1. Lateral bracings can be applied to the compression flange at close intervals, which prevents the lateral translation (buckling) of the beam, as shown in Figure 11.2. This support can be provided by a floor member securely attached to the beam.
2. Cross bracings or a diaphragm can be provided between adjacent beams, as shown in Figure 11.3, which directly prevents the twisting of the sections.

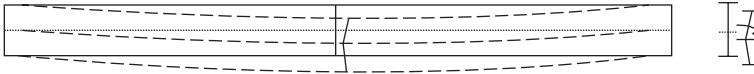


FIGURE 11.1 Buckling and twisting effect in a beam.

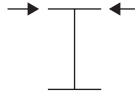


FIGURE 11.2 Lateral bracing of compression flange.



FIGURE 11.3 Cross bracing or diaphragm.

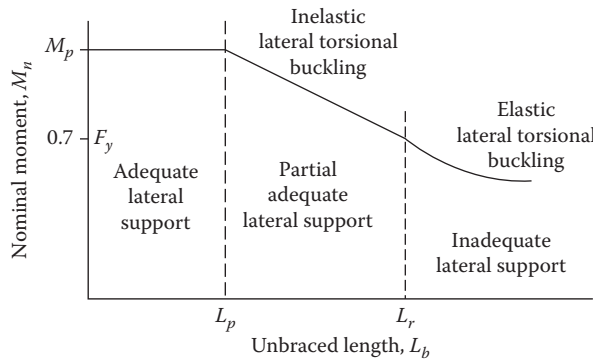


FIGURE 11.4 Nominal moment strength as a function of unbraced length.

Depending on the lateral support condition on the compression side, the strength of the limit state of a beam is due to either the plastic yielding of the section or the lateral torsional buckling of the section. The latter condition has two further divisions: inelastic lateral torsional buckling and elastic lateral torsional buckling. These three zones of the limit states are shown in Figure 11.4 and described here.

In Figure 11.4, the first threshold value for the unsupported or the unbraced length is  $L_p$ , given by the following relation:

$$L_p = 1.76r_y \sqrt{\frac{E}{F_y}} \tag{11.2}$$

where

$L_p$  is first threshold limit for the unsupported length (in inches)

$r_y$  is radius of gyration about the  $y$  axis, listed in the Appendix C, Tables C.1 through C.7

The second threshold value is  $L_r$ , which is conservatively given by the following relation:

$$L_r = \pi r_{ts} \sqrt{\frac{E}{0.7F_y}} \tag{11.3}$$

where

$L_r$  is second threshold of the unsupported length (in inches)

$r_{ts}$  is special radius of gyration for  $L_r$ , listed in Appendix C, Tables C.1 through C.7

### FULLY PLASTIC ZONE WITH ADEQUATE LATERAL SUPPORT

When the lateral support is continuous or closely spaced so that the unbraced (unsupported) length of a beam,  $L_b$ , is less than or equal to  $L_p$  from Equation 11.2, the beam can be loaded to reach the plastic moment capacity throughout the section.

The limit state in this case is the yield strength given as follows:

$$M_u = \phi F_y Z_x, \quad \text{with } \phi = 0.9 \quad (11.4)$$

The lateral torsional buckling does not apply in this zone.

### INELASTIC LATERAL TORSIONAL BUCKLING ZONE

When the lateral unsupported (unbraced) length,  $L_b$ , is more than  $L_p$  but less than or equal to  $L_r$ , the section will not have sufficient capacity to develop the plastic moment capacity, i.e., the full yield stress,  $F_y$ , in the entire section. Before all fibers are stressed to  $F_y$  buckling will occur. This will lead to inelastic lateral torsional buckling.

At  $L_b = L_p$ , the moment capacity is the plastic capacity  $M_p$ . As the length  $L_b$  increases beyond the  $L_p$  value, the moment capacity becomes less. At the  $L_r$  value of the unbraced length, the section buckles elastically, attaining the yield stress only at the top or the bottom fiber. Accounting for the residual stress in the section during manufacturing, the effective yield stress is  $F_y - F_r$ , where  $F_r$  is residual stress. The residual stress is taken as 30% of the yield stress. Thus, at  $L_b = L_r$  the moment capacity is  $(F_y - F_r)S_x$  or  $0.7F_y S$ .

When the unbraced length  $L_b$  is between the  $L_p$  and  $L_r$  values, the moment capacity is linearly interpolated between the magnitudes of  $M_p$  and  $0.7F_y S$  as follows:

$$M_u = \phi \left[ M_p - (M_p - 0.7F_y S) \left( \frac{L_b - L_p}{L_r - L_p} \right) \right] C_b \quad (11.5)$$

where  $M_p = F_y Z_x$

### MODIFICATION FACTOR $C_b$

The factor  $C_b$  is introduced in Equation 11.5 to account for a situation when the moment within the unbraced length is not uniform (constant). A higher moment between the supports increases the resistance to torsional buckling, thus resulting in an increased value of  $C_b$ . This factor has the following values:

	$C_b$
1. No transverse loading between brace points	1
2. Uniformly loaded simple supported beam	1.14
3. Centrally loaded simple supported beam	1.32
4. Cantilever beam	1
5. Equal end moments of opposite signs	1
6. Equal end moments of the same sign (reverse curvature)	2.27
7. One end moment is 0	1.67

A value of 1 is conservatively taken.

**ELASTIC LATERAL TORSIONAL BUCKLING ZONE**

When the unbraced length  $L_b$  exceeds the threshold value of  $L_r$ , the beam buckles before the effective yield stress,  $0.7F_y$ , is reached anywhere in the cross section. This is elastic buckling. The moment capacity is made up of the torsional resistance and the warping resistance of the section:

$$M_u < 0.7\phi F_y S \tag{11.6}$$

At  $L_b = L_r$ , the capacity  $M_u$  is exactly  $0.7\phi F_y S$ .

**NONCOMPACT AND SLENDER BEAM SECTIONS FOR FLEXURE**

The aforementioned discussion on beam strength did not account for the shape of a beam, that is, it assumes that the beam section is robust enough to not create any localized problem. However, if the flange and the web of a section are relatively thin, they might get buckled, as shown in Figure 11.5, even before lateral torsional buckling due to unsupported length of the span happens. This mode of failure is called *flange local buckling* or *web local buckling*.

Sections are divided into three classes based on the width to thickness ratios of the flange and the web. The threshold values of classification are given in Table 11.1.

When  $\lambda \leq \lambda_p$ , the shape is compact.

When  $\lambda > \lambda_p$  but  $\lambda \leq \lambda_r$ , the shape is noncompact.

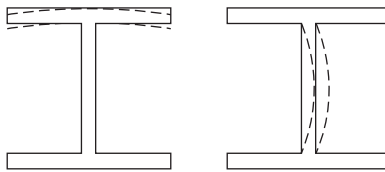
When  $\lambda > \lambda_r$ , the shape is slender.

Both the flange and the web are evaluated by the aforementioned criteria. Based on the aforementioned limits, the flange of a section might fall into one category, whereas the web of the same section might fall into the other category.

The values of  $\lambda_p$  and  $\lambda_r$  for various types of steel are listed in Table 11.2.

In addition to the unsupported length, the bending moment capacity of a beam also depends on the compactness or width–thickness ratio, as shown in Figure 11.6.

This localized buckling effect could be the flange local buckling or the web local buckling depending on which one falls into the noncompact or slender category. All W, S, M, HP, C, and MC shapes listed in the *AISC Manual 2010* have compact webs at  $F_y \leq 65$  ksi. Thus, only the flange criteria need to be applied. Fortunately, most of the shapes also satisfy the flange compactness requirements.



**FIGURE 11.5** Local buckling of section.

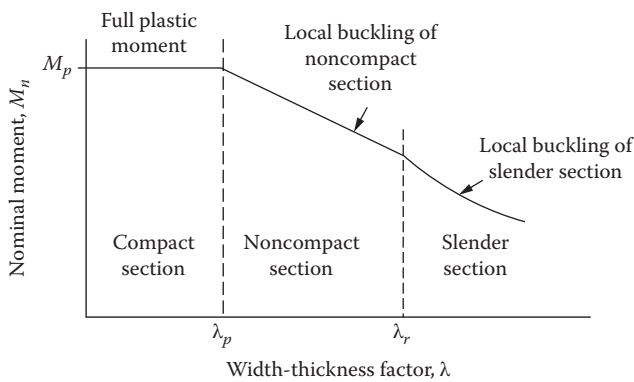
**TABLE 11.1**  
**Shape Classification Limits**

Element	$\lambda$	$\lambda_p$	$\lambda_r$
Flange	$b_f/2t_f^a$	$0.38 \sqrt{\frac{E}{F_y}}$	$1.0 \sqrt{\frac{E}{F_y}}$
Web	$h/t_w$	$3.76 \sqrt{\frac{E}{F_y}}$	$5.70 \sqrt{\frac{E}{F_y}}$

<sup>a</sup> For channel shape, this is  $b/t_f$ .

**TABLE 11.2**  
**Magnitude of the Classification Limits**

Element	Limits	A36	A572
		$F_y = 36 \text{ ksi}$	$F_y = 50 \text{ ksi}$
Flange	$0.38 \sqrt{\frac{E}{F_y}}$	10.79	9.15
	$1.0 \sqrt{\frac{E}{F_y}}$	28.38	24.08
Web	$3.76 \sqrt{\frac{E}{F_y}}$	106.72	90.55
	$5.70 \sqrt{\frac{E}{F_y}}$	161.78	137.27



**FIGURE 11.6** Nominal moment strength as a function of compactness.

Without accounting for the lateral unsupported length effect, that is, assuming a fully laterally supported beam, the strength limits described in the following sections are applicable based on the compactness (width-thickness) criteria.

**COMPACT FULL PLASTIC LIMIT**

As long as  $\lambda \leq \lambda_p$ , the beam moment capacity is equal to  $M_p$  and the limit state of the moment is given by the yield strength expressed by Equation 11.4.

**NONCOMPACT FLANGE LOCAL BUCKLING\***

For sections having a value of  $\lambda$  between the  $\lambda_p$  and  $\lambda_r$  limits shown in Table 11.1, the moment capacity is interpolated between  $M_p$  and  $0.7F_y S$  as a gradient of the  $\lambda$  values on the same line like Equation 11.5, expressed as follows:

$$M_u = \phi \left[ M_p - (M_p - 0.7F_y S) \left( \frac{\lambda - \lambda_p}{\lambda_r - \lambda_p} \right) \right] \tag{11.7}$$

\* All webs are compact for  $F_y = 36 \text{ ksi}$  and  $50 \text{ ksi}$ .

### SLENDER FLANGE LOCAL BUCKLING

For sections with  $\lambda > \lambda_r$ , the moment-resisting capacity is inversely proportional to the square of slenderness ratio, as follows:

$$M_u = \frac{0.9\phi E k_c S}{\lambda^2} \tag{11.8}$$

where  $k_c = \frac{4}{\sqrt{hlt_w}}$ , where  $k_c \geq 0.35$  and  $\leq 0.76$ .

### SUMMARY OF BEAM RELATIONS

Considering both the lateral support and the compactness criteria, the flexural strength (the moment capacity) is taken to be the lowest value obtained according to the limit states of the lateral torsional buckling and the compression flange local buckling. The applicable limits and corresponding equations are shown in Table 11.3. Most of the beam sections fall in the full plastic zone where Equation 11.4 can be applied. In this chapter, it is assumed that the condition of adequate lateral

**TABLE 11.3**  
**Applicable Limiting States of Beam Design**

Zone	Unbraced Length, $L_b$	Flange Local Buckling <sup>a</sup>		
		Compact $\lambda < \lambda_p$	Noncompact (inelastic) $\lambda > \lambda_p$ and $\leq \lambda_r$	Slender (Elastic) $\lambda > \lambda_r$
Fully plastic	Adequate lateral support $L_b \leq L_p$	Limit state: Yield strength: Equation 11.4 <sup>b</sup> lateral torsional buckling does not apply	Limit state: Inelastic flange local buckling: Equation 11.7 lateral torsional buckling does not apply	Limit state: Elastic flange local buckling: Equation 11.8 lateral torsional buckling does not apply
Lateral torsional buckling	Partial inadequate support $L_b > L_p$ and $L_b \leq L_r$	Limit state: Inelastic lateral torsional buckling: Equation 11.5	Limit states: Lower of the following two: 1. Inelastic lateral torsional buckling: Equation 11.5 2. Noncompact flange local buckling: Equation 11.7	Limit states: Lower of the following two: 1. Inelastic lateral torsional buckling: Equation 11.5 2. Slender flange local buckling: Equation 11.8
Lateral torsional buckling	Inadequate support, $L_b > L_r$	Limit state: Elastic lateral torsional buckling: Equation 11.6	Limit states: Lower of the following two: 1. Elastic lateral torsional buckling: Equation 11.6 2. Noncompact flange local buckling: Equation 11.7	Limit states: Lower of the following two: 1. Elastic lateral torsional buckling: Equation 11.6 2. Slender flange local buckling: Equation 11.8

<sup>a</sup> Web local buckling is not included since all I-shaped and C-shaped sections have compact webs. In the case of a web local buckling member, formulas are similar to the flange local buckling. Equations 11.7 and 11.8 but are modified for (1) the web plastification factor ( $R_{pc}$ ) and (2) the bending strength reduction factor ( $R_{pg}$ ).

<sup>b</sup> Most beams fall into the adequate laterally supported compact category. This chapter considers only this state of design.



---

**TABLE 11.4**  
**List of Noncompact Flange Sections**

W21 × 48
W14 × 99
W14 × 90
W12 × 65
W10 × 12
W8 × 31
W8 × 10
W6 × 15
W6 × 9
W6 × 8.5
M4 × 6

---

support will be satisfied, if necessary, by providing bracings at intervals less than the distance  $L_p$  and also that the condition of flange and web compactness is fulfilled.

*AISC Manual 2010* also covers cases of noncompact and slender web buckling. The equations are similar to Equations 11.4, 11.7, and 11.8 from the flange buckling cases with the application of a web plastification factor,  $R_{pc}$ , for a noncompact web and a bending strength reduction factor,  $R_{pg}$ , for a slender web.

However, as stated in the “Noncompact and Slender Beam Sections for Flexure” section, all W, S, M, HP, C, and MC shapes have compact webs for  $F_y$  of 36, 50, and 65 ksi. All W, S, M, C, and MC shapes have compact flanges for  $F_y$  of 36 and 50 ksi, except for the sections listed in Table 11.4. Thus, a beam will be compact if the sections listed in Table 11.4 are avoided.

## DESIGN AIDS

*AISC Manual 2010* provides the design tables. A beam can be selected by entering the table either with the required section modulus or with the design bending moment.

These tables are applicable to adequately support compact beams for which yield limit state is applicable. For simply supported beams with uniform load over the entire span, tables are provided that show the allowable uniform loads corresponding to various spans. These tables are also for adequately supported beams but extend to noncompact members as well.

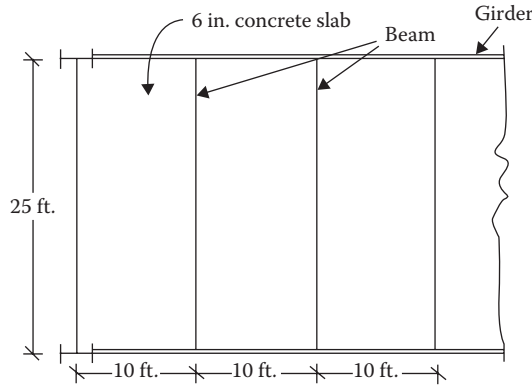
Also included in the manual are more comprehensive charts that plot the total moment capacity against the unbraced length starting at spans less than  $L_p$  and continuing to spans greater than  $L_r$ , covering compact as well as noncompact members. These charts are applicable to the condition  $C_b = 1$ . The charts can be directly used to select a beam section.

A typical chart is given in Appendix C, Table C.9. Enter the chart with given unbraced length on the bottom scale, and proceed upward to meet the horizontal line corresponding to the design moment on the left-hand scale. Any beam listed above and to the right of the intersection point will meet the design requirement. The section listed at the first solid line after the intersection represents the most economical section.

### Example 11.1

A floor system is supported by steel beams, as shown in Figure 11.7. The live load is 100 psf. Design the beam. Determine the maximum unbraced length of beam to satisfy the requirement of adequate lateral support.

$$F_y = 50 \text{ ksi}$$



**FIGURE 11.7** A floor system supported by beams.

### SOLUTION

#### A. Analytical

1. Tributary area of beam per foot =  $10 \times 1 = 10 \text{ ft.}^2/\text{ft.}$
2. Weight of slab per foot =  $1 \times 10 \times \frac{6}{12} \times 150 = 750 \text{ lb/ft.}$
3. Estimated weight of beam per foot =  $30 \text{ lb/ft.}$
4. Dead load per foot =  $780 \text{ lb/ft.}$
5. Live load per foot =  $100 \times 10 = 1000 \text{ lb/ft.}$
6. Design load per foot:

$$w_u = 1.2(780) + 1.6(1000) = 2536 \text{ lb/ft.} \quad \text{or} \quad 2.54 \text{ k/ft.}$$

7. Design moment:

$$M_u = \frac{w_u l^2}{8} = \frac{2.54(25)^2}{8} = 198.44 \text{ ft.} \cdot \text{k}$$

8. From Equation 11.4,

$$Z_x = \frac{198.44(12)}{(0.9)(50)} = 52.91 \text{ in.}^3$$

9. Select  $W14 \times 34$

$$Z_x = 54.6 \text{ in.}^3$$

$$r_x = 5.83 \text{ in.}$$

$$r_y = 1.53 \text{ in.}$$

$$\frac{b_f}{2t_f} = 7.41$$

$$\frac{h}{t_w} = 43.1$$

10. Since  $\frac{b_f}{2t_f} = 7.41 < 9.15$  from Table 11.2, it is a compact flange.

Since  $\frac{h}{t_w} = 43.1 < 90.55$  from Table 11.2, it is a compact web.

Equation 11.4 applies; selection is **OK**.

11. Unbraced length from Equation 11.2:

$$\begin{aligned} L_p &= 1.76 r_y \sqrt{\frac{E}{F_y}} \\ &= 1.76(1.53) \sqrt{\frac{29,000}{50}} \\ &= 64.85 \text{ in.} \quad \text{or} \quad 5.4 \text{ ft.} \end{aligned}$$

- B. Use of chart:

- From Appendix C, Table C.9, for an unbraced length of 45.4 ft. and a design moment of 198 ft.·k, the suitable sections are W16 × 31 and W14 × 34.

### Example 11.2

The compression flange of the beam in Example 11.1 is braced at a 10 ft. interval. Design the beam when the full plastic limit state applies (adequate lateral support exists).

### SOLUTION

- At upper limit,  $L_b = L_p$

$$\text{or } 10 \times 12 = 1.76 r_y \sqrt{\frac{29,000}{50}}$$

$$\text{or } r_y = 2.83 \text{ in. minimum}$$

- Select W14 × 109

$$Z_x = 192 \text{ in.}^3$$

$$r_y = 3.73 \text{ in.}$$

$$\frac{b_f}{2t_f} = 8.49$$

$$\frac{h}{t_w} = 21.7$$

- $M_u = \phi F_y Z_x = (0.9)(50)(192) = 8640 \text{ in.}\cdot\text{k}$  or  $720 \text{ ft.}\cdot\text{k} > 198.44$  **OK**

- Since  $\frac{b_f}{2t_f} = 8.49 < 9.15$  compact

$$\text{Since } \frac{h}{t_w} = 21.7 < 90.55 \text{ compact}$$

### Example 11.3

The compression flange of the beam in Example 11.1 is braced at a 10 ft. interval. Design the beam when the inelastic lateral torsional limit state applies.

**SOLUTION**

A. Analytical

1. At upper limit,  $L_b = L_r$ 

$$\text{or } 10 \times 12 = \pi r_{ts} \sqrt{\frac{29,000}{(0.7)50}}$$

or  $r_{ts} = 1.33$  in. minimum2. Minimum  $Z_x$  required for the plastic limit state:

$$Z_x = \frac{M_u}{\phi F_y} = \frac{198.44 \times 12}{(0.9)(50)} = 52.2 \text{ in.}^3$$

3. Select W14  $\times$  43

$$Z_x = 69.6 \text{ in.}^3$$

$$S_x = 62.6 \text{ in.}^3$$

$$r_y = 1.89 \text{ in.}$$

$$r_{ts} = 2.18 \text{ in.} > \text{minimum } r_{ts} \text{ of } 1.33$$

$$\frac{b_f}{2t_f} = 7.54$$

$$\frac{h}{t_w} = 37.4$$

$$4. L_p = 1.76(1.89) \sqrt{\frac{29,000}{50}} = 80.11 \text{ in. or } 6.68 \text{ ft.}$$

$$L_r = \pi(2.18) \sqrt{\frac{29,000}{50}} = 197.04 \text{ in. or } 16.42 \text{ ft.}$$

$$5. M_p = F_y Z_x = 50(69.6) = 3480 \text{ in.} \cdot \text{k}$$

$$0.7F_y S_x = 0.7(500)(62.6) = 2190 \text{ in.} \cdot \text{k}$$

$$6. M_u = \phi \left[ M_p - (M_p - 0.7F_y S_x) \frac{(L_b - L_p)}{(L_r - L_b)} \right] C_b$$

$$= 0.9 \left[ 3480 - (3480 - 2190) \frac{(10 - 6.68)}{(16.42 - 6.68)} \right] (1)$$

$$= 2736.3 \text{ in.} \cdot \text{k or } 228 \text{ ft.} \cdot \text{k} > 198.44 \text{ ft.} \cdot \text{k} \quad \text{OK}$$

$$7. \text{ Since } \frac{b_f}{2t_f} = 7.54 < 9.15 \text{ compact}$$

$$\text{Since } \frac{h}{t_w} = 37.4 < 90.55 \text{ compact}$$

B. Use of the chart

From Appendix C, Table C.9, for an unbraced length of 10 ft. and a design moment of 198 ft.  $\cdot$  k, W14  $\times$  43 is a suitable section.**SHEAR STRENGTH OF STEEL**

The section of beam selected for the moment capacity is checked for its shear strength capacity. The design relationship for shear strength is

$$V_u = \phi_v V_n \quad (11.9)$$

where

- $V_u$  is factored shear force applied
- $\phi_v$  is resistance factor for shear
- $V_n$  is nominal shear strength

Similar to noncompact and slender sections for flexure, for shear capacity a section is also compact, noncompact, or slender depending on the  $h/t_w$  ratio. The limits are defined as follows:

$$l_p^* = 2.46 \sqrt{E/F_y}$$

$$l_r = 3.06 \sqrt{E/F_y}$$

1. When,  $h/t_w \leq l_p$ , the web is compact for shear.
2. When,  $h/t_w > l_p$  but  $\leq l_r$ , the web is noncompact for shear.
3. When,  $h/t_w > l_r$ , the web is slender for shear.

Depending on the aforementioned three values, the following three limits apply to shear capacity:

1. For case 1 with a compact web, the limit state is plastic web yielding.
2. For case 2 with a noncompact web, the limit state is inelastic web buckling.
3. For case 3 with a slender web, the limit state is elastic web buckling.

The variation of shear strength in the three limiting states is very similar to that of the flexure strength shown in Figure 11.6.

With the exception of a few M shapes, all W, S, M, and HP shapes of  $F_y = 50$  steel have the compact web to which the plastic web yielding limit applies.

Under the plastic web yielding limit, the following two criteria apply:

1. For all I-shaped members with  $h/t_w \leq 2.24 \sqrt{E/F_y}$ ,

$$V_u = 0.6\phi F_y A_w \quad (11.10)$$

where

$$\phi = 1$$

$$A_w = dt_w$$

2. For all other doubly symmetric and singly symmetric shapes, except round HSS,  $\phi$  reduces to 0.9 and

$$V_u = 0.6(0.9) F_y A_w \quad (11.11)$$

However, as the ratio of depth to thickness of web,  $h/t_w$ , exceeds  $2.46 \sqrt{E/F_y}$ , inelastic web buckling occurs, whereby Equation 11.11 is further multiplied by a reduction factor  $C_v$ .

At an  $h/t_w$  exceeding  $3.06 \sqrt{E/F_y}$ , the elastic web buckling condition sets in and the factor  $C_v$  is further reduced.

However, as stated, most of the sections of  $F_y < 50$  ksi steel have compact shapes that satisfy Equation 11.10.

---

\* This limit is  $1.10\sqrt{K_v E/F_y}$ , where  $K_v = 5$  for webs without transverse stiffness and  $h/t_w \leq 260$ , which is an upper limit for girders.

**Example 11.4**

Check the beam of Example 11.1 for shear strength.

**SOLUTION**

1.  $V_u = \frac{w_u L}{2}$   
 $= \frac{2.54(25)}{2} = 31.75 \text{ k}$
2. For W14  $\times$  34,  $h/t_w = 43.1$   
 $A_w = dt_w = 14(0.285) = 3.99$   
 $2.24 \sqrt{E/F_y} = 53.95$
3. Since  $h/t_w \leq 2.24 \sqrt{E/F_y}$ ; the plastic web yielding limit  
 $V_u = 0.6\phi F_y A_w = 0.6(1)(50)(3.99) = 119.7 \text{ k} > 31.75 \text{ k}$  **OK**

**BEAM DEFLECTION LIMITATIONS**

Deflection is a service requirement. A limit on deflection is imposed so that the serviceability of a floor or a roof is not impaired due to the cracking of plastic, or concrete slab, or the distortion of partitions or any other kind of undesirable occurrence. There are no standard limits because such values depend on the function of a structure. For cracking of plaster, usually a live load deflection limit of span/360 and a total load limit of span/240 are observed. It is imperative to note that, being a serviceability consideration, the deflections are always computed with service (unfactored) loads and moments.

For a common case of a uniformly distributed load on a simple beam, the deflection is given by the following formula:

$$\delta = \frac{5}{384} \frac{wL^4}{EI} \quad (11.12)$$

However, depending on the loading condition the theoretical derivation of the expression for deflection might be quite involved. For various load conditions on simply supported beam, cantilever and fixed beams, the deflections are given in Appendix A, Table A.3.3. For commonly encountered load conditions in simply supported and cantilever beams, when the expression of the bending moment is substituted in the deflection expression, a generalized form of deflection can be expressed as follows:

$$\delta = \frac{ML^2}{CEI} \quad (11.13)$$

where

- $w$  is combination of the service loads
- $M$  is moment due to the service loads


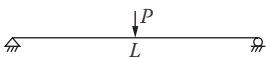
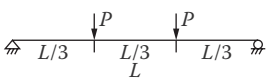
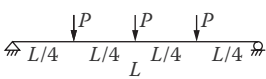
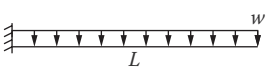
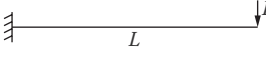
The values of constant  $C$  are indicated in Table 11.5 for different load cases.

In a simplified form, the designed factored moment,  $M_u$ , can be converted to the service moment by dividing by a factor of 1.5 (i.e.,  $M = M_u/1.5$ ). The service live load moment,  $M_L$ , is approximately

---

\* In foot-pound-second units, the numerator is multiplied by  $(12)^3$  to convert  $\delta$  in inch unit when  $w$  is kips per foot,  $L$  is in feet,  $E$  is in kips per square inch, and  $I$  is in  $\text{inch}^4$ . Similarly, Equation 11.12 is also multiplied by  $(12)^3$  when  $M$  is in foot kips.

**TABLE 11.5**  
**Deflection Loading Constants**

Diagram of Load Condition	Constant C for Equation 11.13
	9.6
	12
	9.39
	10.13
	4
	3

two-thirds of the total moment  $M$  (i.e.,  $M_L = 2M_u/4.5$ ). The factor  $C$  from Table 11.5 can be used in Equation 11.13 to compute the expected deflection, which should be checked against the permissible deflection,  $\Delta$ , to satisfy the deflection limitation.

**Example 11.5**

Check the beam in Example 11.1 for deflection limitation. The maximum permissible live load deflection is  $L/360$ . Use (1) the conventional method and (2) the simplified procedure.

**SOLUTION**

a. Conventional method

1. Service live load = 1000 lb/ft. or 1 k/ft.
2. For W14 × 34,  $I = 340 \text{ in.}^4$
3. From Equation 11.12

$$\delta = \frac{5}{384} \frac{(1.0)(25)^4(12)^3}{(29,000)(340)} = 0.89 \text{ in.}$$

4. 
$$= \frac{L \times 12}{360}$$

$$= \frac{25 \times 12}{360} \text{ a}$$

$$= 0.83 \text{ in.}$$

Since 0.89 in. > 0.83 in., **NG** (border case).

b. Simplified procedure

1. 
$$M_L = \frac{2M_u}{4.5} = \frac{2(198.44)}{4.5} = 88.20 \text{ ft.} \cdot \text{k}$$

2. From Equation 11.13

$$\delta = \frac{ML^2 \times (12)^3}{CEI}$$

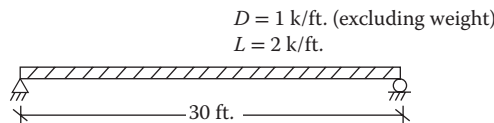
$$= \frac{(88.20)(25)^2(12)^3}{(9.6)(290,000)(340)}$$

$$= 0.99 \text{ in.}$$

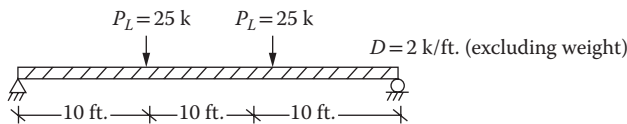
3.  $\Delta < \delta$  **NG** (border case)

**PROBLEMS**

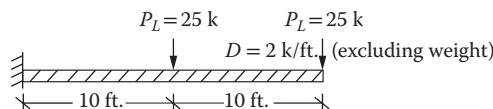
- 11.1** Design a beam of A36 steel for the loads in Figure P11.1. Determine the maximum unbraced length of beam to satisfy the requirement of adequate lateral support.
- 11.2** Design a simply supported 20 ft. span beam of A992 steel having the following concentrated loads at the midspan. Determine the maximum unbraced length of beam to satisfy the requirement of adequate lateral support.  
Service dead load = 10 k  
Service live load = 25 k
- 11.3** Design a beam of A992 steel for the loading shown in Figure P11.2. The compression flange bracing is provided at each concentrated load. The selected section should be such that the full lateral support condition is satisfied. Determine the maximum unbraced length of beam to satisfy the requirement of adequate lateral support.
- 11.4** Design a cantilever beam of A992 steel for the loading shown in Figure P11.3. The compression flange bracing is provided at each concentrated load. The selected section should be such that the full lateral support condition is satisfied. Determine the maximum unbraced length of beam to satisfy the requirement of adequate lateral support.
- 11.5** A floor system supporting a 6 in. concrete slab is shown in Figure P11.4. The live load is 100 psf. Design a beam of section W14× ... of A36 steel. Recommend the compression flange bracing so that the beam has the full lateral support.
- 11.6** Design a W18× ... section of A992 steel girder for Problem 11.5. Recommend the compression flange bracing so that the beam has the full lateral support.



**FIGURE P11.1** Beam for Problem 11.1.

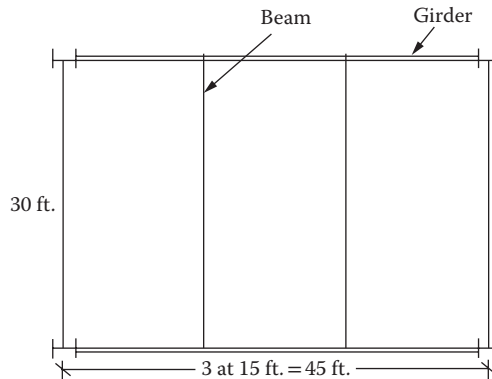


**FIGURE P11.2** Beam for Problem 11.3.



**FIGURE P11.3** Beam for Problem 11.4.





**FIGURE P11.4** Floor system for Problem 11.5.

- 11.7** The beam in Problem 11.6 is braced at a 15 ft. interval. Design a W14× ... section of A992 steel for the full plastic limit state (for the adequate lateral support case).
- 11.8** The beam in Problem 11.6 is braced at a 15 ft. interval. Design a W14× ... section of A992 steel for the inelastic lateral torsional buckling limit state.
- 11.9** From the sections listed, sort out which of the sections of A992 steel are compact, noncompact, and slender:  
 (1) W21 × 93, (2) W18 × 97, (3) W14 × 99, (4) W12 × 65, (5) W10 × 68, (6) W8 × 31, (7) W6 × 15.
- 11.10** A grade 50 W21 × 62 section is used for a simple span of 20 ft. The only dead load is the weight of the beam. The beam is fully laterally braced. What is the largest service concentrated load that can be placed at the center of the beam? What is the maximum unbraced length?
- 11.11** A W18 × 97 beam of A992 steel is selected to span 20 ft. If the compression flange is supported at the end and at the midpoint. Which formula do you recommend to solve for the moment capacity? Determine the maximum unbraced length of beam to satisfy the requirement of adequate lateral support.
- 11.12** A W18 × 97 beam of A992 steel is selected to span 20 ft. It is supported at the ends only. Which formula do you recommend to solve for the moment capacity?
- 11.13** A W21 × 48 section is used to span 20 ft. and is supported at the ends only. Which formula do you recommend to solve for the moment capacity?
- 11.14** A W21 × 48 section is used to span 20 ft. and is supported at the ends and the center. Which formula do you recommend to solve for the moment capacity?
- 11.15** Check the selected beam section in Problem 11.1 for shear strength capacity.
- 11.16** Check the selected beam section in Problem 11.2 for shear strength capacity.
- 11.17** Check the selected beam section in Problem 11.3 for shear strength capacity.
- 11.18** What is the shear strength of the beam of a W16 × 26 A992 beam?
- 11.19** What is the shear strength of the beam of a W12 × 14 A992 beam?
- 11.20** Compute the total load and the live load deflections for the beam in Problem 11.1 by (1) the conventional method and (2) the simplified procedure. The permissible deflection for total load is  $L/240$  and for live load is  $L/360$ .
- 11.21** Compute the total load and the live load deflections for the beam in Problem 11.2 by (1) the conventional method and (2) the simplified procedure. The permissible deflection for total load is  $L/240$  and for live load is  $L/360$ .
- 11.22** Compute the total load and the live load deflections for the beam in Problem 11.3 by (1) the conventional method and (2) the simplified procedure. The permissible deflection for total load is  $L/240$  and for live load is  $L/360$ . Redesign the beam if necessary.

- 11.23** Check the total load and the live load deflections for the beam in Problem 11.5 by (1) the conventional method and (2) the simplified procedure. The permissible deflection for total load is  $L/240$  and for live load is  $L/360$ . Redesign the beam if necessary.
- 11.24** Check the total load and the live load deflections for the beam in Problem 11.6 by (1) the conventional method and (2) the simplified procedure. The permissible deflection for total load is  $L/240$  and for live load is  $L/360$ . Redesign the beam if necessary.

---

# 12 Combined Forces on Steel Members

## DESIGN APPROACH TO COMBINED FORCES

The design of tensile, compression, and bending members was separately treated in Chapters 9, 10, and 11, respectively. In actual structures, the axial and the bending forces generally act together, specifically the compression due to gravity loads and the bending due to lateral loads. An interaction formula is the simplest way for such cases wherein the sum of the ratios of factored design load to limiting axial strength and factored design moment to limiting moment strength should not exceed 1.

Test results show that assigning an equal weight to the axial force ratio and the moment ratio in the interaction equation provides sections that are too large. Accordingly, the American Institute of Steel Construction (AISC) suggested the following modifications to the interaction equations in which the moment ratio is reduced when the axial force is high and the axial force ratio is reduced when the bending moment is high:

1. For  $\frac{P_u}{\phi P_n} \geq 0.2$

$$\frac{P_u}{\phi P_n} + \frac{8}{9} \left( \frac{M_{ux}}{\phi_b M_{nx}} + \frac{M_{uy}}{\phi_b M_{ny}} \right) \leq 1 \quad (12.1)$$

2. For  $\frac{P_u}{\phi P_n} < 0.2$

$$\frac{1}{2} \frac{P_u}{\phi P_n} + \left( \frac{M_{ux}}{\phi_b M_{nx}} + \frac{M_{uy}}{\phi_b M_{ny}} \right) \leq 1 \quad (12.2)$$

where

$\phi$  is resistance factor for axial force (0.9 or 0.75 for tensile member and 0.9 for compression member)

$\phi_b$  is resistance factor for bending (0.9)

$P_u$  is factored design load, determined by structural analysis (required force)

$P_n$  is nominal axial capacity, determined according to Chapters 9 and 10

$M_{ux}$  and  $M_{uy}$  are factored design moments about  $x$  and  $y$  axes as determined by structural analysis including second-order effects (required moments)

$M_{nx}$  and  $M_{ny}$  are nominal bending capacities along  $x$  and  $y$  axes if only bending moments were present, which are determined by different methods mentioned in Chapter 11

## COMBINATION OF TENSILE AND FLEXURE FORCES

Some members of a structural system are subject to axial tension as well as bending. An example is the bottom chord of a trussed bridge. The hanger type of structures acted upon by transverse loads is another example.

The analysis in which a member size is known and the adequacy of the member to handle a certain magnitude of force is to be checked is a direct procedure with Equation 12.1 or 12.2. However, the design of a member that involves the selection of a suitable size for a known magnitude of load is a trial-and-error procedure by the interaction equation, Equations 12.1 or 12.2. *AISC Manual 2010* presents a simplified procedure to make an initial selection of a member size. This procedure, however, necessitates the application of factors that are available from specific tables in the manual. Since the manual is not a precondition for this chapter, that procedure is not used here.

### Example 12.1

Design a member to support the load shown in Figure 12.1. It has one line of four holes for a 7/8 in. bolt in the web for the connection. The beam has adequate lateral support. Use grade 50 steel.

### SOLUTION

#### A. Analysis of structure

1. Assume a beam weight of 50 lb/ft.
2.  $W_u = 1.2(2.05) = 2.46$  k/ft.
3.  $M_u = \frac{W_u L^2}{8} = \frac{(2.46)(12)^2}{8} = 44.28$  ft.-k or 531.4 in.-k
4.  $P_u = 1.6(100) = 160$  k

#### B. Design

1. Try a W10 × 26 section.\*
2.  $A_g = 7.61$  in.<sup>2</sup>
3.  $I_x = 144$  in.<sup>4</sup>
4.  $Z_x = 31.3$  in.<sup>3</sup>
5.  $t_w = 0.26$  in.
6.  $b_f/2t_f = 6.56$
7.  $h/t_w = 34.0$

#### C. Axial (tensile) strength

1.  $U = 0.7$  from the "Shear Lag" section of Chapter 9 for W shapes;  $h = 7/8 + 1/8 = 1$ ,  
 $A_h = 1(0.26) = 0.26$  in.<sup>2</sup>
2.  $A_n = A_g - A_h = 7.61 - 0.26 = 7.35$  in.<sup>2</sup>
3.  $A_e = 0.7(7.35) = 5.15$  in.<sup>2</sup>
4. Tensile strength  
 $\phi F_y A_g = 0.9(50)(7.62) = 342.9$  k  
 $\phi F_u A_e = 0.75(65)(5.15) = 251.06$  k ← Controls

#### D. Moment strength

1.  $0.38 \sqrt{\frac{E}{F_y}} = 9.15 > 6.56$ ; it is a compact flange  
 $3.76 \sqrt{\frac{E}{R_y}} = 90.55 > 34.0$ ; it is a compact web
2. Adequate lateral support (given)
3. Moment strength  
 $\phi_b F_y Z = 0.9(50)(31.3) = 1408.5$  in.-k

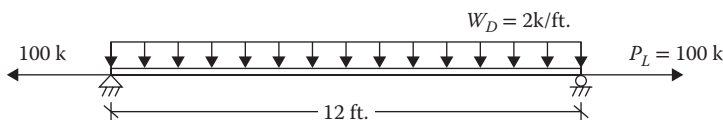


FIGURE 12.1 A tensile and flexure forces member.

\* As a guess, the minimum area for axial load alone should be  $A_u = P_u / \phi F_y = 160 / 0.9(50) = 3.55$  in.<sup>2</sup>. The selected section is twice this size because a moment,  $M_u$ , is also acting.

E. Interaction equation

1. Since  $\frac{P_u}{\phi P_n} = \frac{160}{251.06} = 0.64 > 0.2$ , use Equation 12.1
2.  $\frac{P_u}{\phi P_n} + \frac{8}{9} \left( \frac{M_{ux}}{\phi M_{nx}} \right)$   
 $(0.64) + \frac{8}{9} \left( \frac{531.4}{1408.5} \right) = 0.97 < 1$  **OK**

**COMBINATION OF COMPRESSION AND FLEXURE FORCES: THE BEAM-COLUMN MEMBERS**

Instead of axial tension, when an axial compression acts together with a bending moment, which is a more frequent case, a secondary effect sets in. The member bends due to the moment. This causes the axial compression force to act off center, resulting in an additional moment equal to axial force times lateral displacement. This additional moment causes further deflection, which in turn produces more moment, and so on until an equilibrium is reached. This additional moment, known as the  $P-\Delta$  effect, or the *second-order moment*, is not as much of a problem with axial tension, which tends to reduce the deflection.

There are two kinds of second-order moments, as discussed in the following sections.

**MEMBERS WITHOUT SIDESWAY**

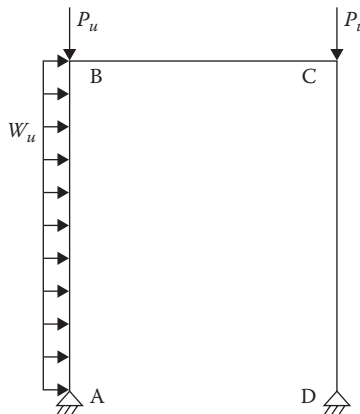
Consider an isolated beam-column member AB of a frame with no sway in Figure 12.2. Due to load  $w_u$  on the member itself, a moment  $M_{u1}$  results assuming that the top joint B does not deflect with respect to the bottom joint A (i.e., there is no sway). This causes the member to bend, as shown in Figure 12.3. The total moment consists of the primary (first-order) moment,  $M_{u1}$ , and the second-order moment,  $P_u \delta$ . Thus,

$$M_{nosway} = M_{u1} + P_u \delta \tag{12.3}$$

where  $M_{u1}$  is the first-order moment in a member assuming no lateral movement (no translation).

**MEMBERS WITH SIDESWAY**

Now consider that the frame is subject to a sidesway where the ends of the column can move with respect to each other, as shown in Figure 12.4.  $M_{u2}$  is the primary (first-order) moment caused by the lateral translation only of the frame. Since the end B is moved by  $\Delta$  with respect to A, the second-order moment is  $P_u \Delta$ .



**FIGURE 12.2** Second-order effect on a frame.

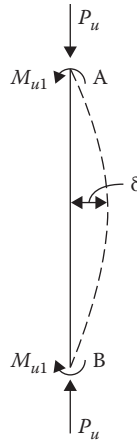


FIGURE 12.3 Second-order moment within a member.

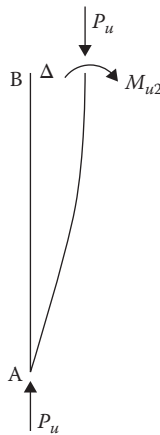


FIGURE 12.4 Second-order moment due to sidesway.

Therefore, the total moment is

$$M_{sway} = M_{u2} + P_u \Delta \tag{12.4}$$

where  $M_{u2}$  is the first-order moment caused by the lateral translation.

It should be understood that the moment  $M_{nosway}$  (Equation 12.3) is the property of the member and the moment  $M_{sway}$  (Equation 12.4) is a characteristic of a frame. When a frame is braced against sidesway,  $M_{sway}$  does not exist. For an unbraced frame, the total moment is the sum of  $M_{nosway}$  and  $M_{sway}$ . Thus,

$$M_u = (M_{u1} + P_u \delta) + (M_{u2} + P_u \Delta) \tag{12.5}$$

The second-order moments are evaluated directly or through the factors that magnify the primary moments. In the second case,

$$M_u = B_1 M_{u1} + B_2 M_{u2} \tag{12.6}$$

(nosway)    (sway)

where  $B_1$  and  $B_2$  are magnification factors when first-order moment analysis is used.

For braced frames, only the factor  $B_1$  is applied. For unbraced frames, both factors  $B_1$  and  $B_2$  are applied.

**MAGNIFICATION FACTOR  $B_1$**

This factor is determined assuming the braced (no sway) condition. It can be demonstrated that for a sine curve the magnified moment directly depends on the ratio of the applied axial load to the elastic (Euler) load of the column. The factor is expressed as follows:

$$B_1 = \frac{C_m}{1 - (P_u/P_{e1})} \geq 1 \tag{12.7}$$

where

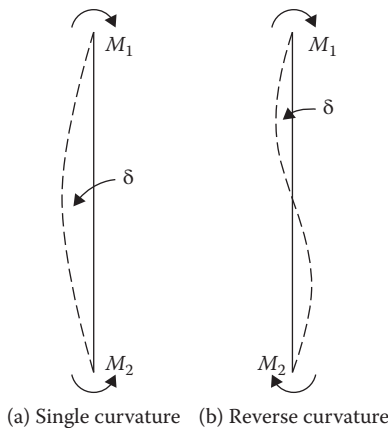
- $C_m$  is moment modification factor discussed below
- $P_u$  is applied factored axial compression load
- $P_{e1}$  is Euler buckling strength, which is given as follows:

$$P_{e1} = \frac{\pi^2 EA}{(KL/r)^2} \tag{12.8}$$

The slenderness ratio  $(KL/r)$  is along the axis on which the bending occurs. Equation 12.7 suggests that  $B_1$  should be greater than or equal to 1; it is a magnification factor.

**MOMENT MODIFICATION FACTOR,  $C_m$**

The modification factor  $C_m$  is an expression that accounts for the nonuniform distribution of the bending moment within a member. Without this factor,  $B_1$  may be overmagnified. When a column is bent in a single curvature with equal end moments, deflection occurs, as shown in Figure 12.5a. In this case,  $C_m = 1$ . When the end moments bend a member in a reverse curvature, as shown in Figure 12.5b, the maximum deflection that occurs at some distance away from the center is smaller than the first case; using  $C_m = 1$  will overdo the magnification. The purpose of the modifier  $C_m$  is to reduce the magnified moment when the variation of the moment within a member requires that  $B_1$  should be reduced. The modification factor depends on the rotational restraint placed at the member’s ends. There are two types of loadings for  $C_m$ :



**FIGURE 12.5** Deflection of a column under different end moment conditions.

1. When there is no transverse loading between the two ends of a member, the modification factor is given by

$$C_m = 0.6 - 0.4 \left( \frac{M_1}{M_2} \right) \leq 1 \quad (12.9)$$

where

$M_1$  is the smaller end moment

$M_2$  is the larger of the end moments

The ratio  $(M_1/M_2)$  is negative when the end moments have opposite directions, causing the member to bend in a single curvature. (This is opposite to the sign convention for concrete columns in the “Short Columns with Combined Loads” section in Chapter 16.)

The ratio is taken to be positive when the end moments have the same direction, causing the member to bend in a reverse curvature.

2. When there is a transverse loading between the two ends of a member,
- $C_m = 0.85$  for a member with the restrained (fixed) ends
  - $C_m = 1.0$  for a member with unrestrained ends

### Example 12.2

The service loads\* on a W12 × 72 braced frame member of A572 steel are shown in Figure 12.6. The bending is about the strong axis. Determine the magnification factor  $B_1$ . Assume the pinned-end condition.

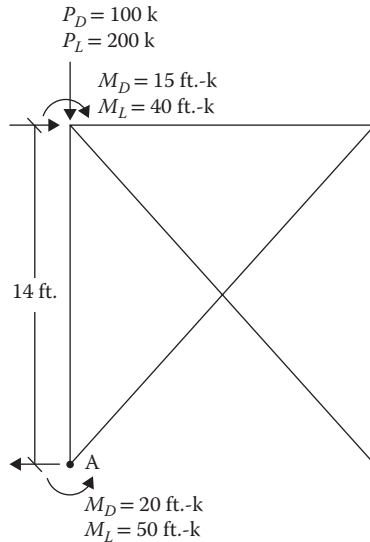


FIGURE 12.6 Braced frame for Example 12.2.

### SOLUTION

#### A. Design loads

- Weight =  $72(14) = 1008$  lb or 1 k
- $P_u = 1.2(101) + 1.6(200) = 441$  k
- $(M_{u1})_B = 1.2(15) + 1.6(40) = 82$  ft.-k
- $(M_{u1})_A = 1.2(20) + 1.6(50) = 104$  ft.-k

\* Axial load on a frame represents the loads from all the floors above up to the frame level in question.



B. Modification factor

1.  $\frac{M_1}{M_2} = \frac{-82}{104} = -0.788$
2.  $C_m = 0.6 - 0.4(-0.788) = 0.915$

C. Euler buckling strength

1. For a braced frame,  $K = 1$
2. For W12 × 72,  $A = 21.1 \text{ in.}^2$   
 $r_x = 5.31 \text{ in.}$ , bending in the x direction

$$3. \frac{KL}{r_x} = \frac{(1)(14 \times 12)}{5.31} = 31.64$$

$$4. P_{e1} = \frac{\pi^2 EA}{(KL/r)^2} = \frac{\pi^2(29,000)(21.2)}{(31.64)^2} = 6,055\text{k}$$

$$5. B_1 = \frac{C_m}{1 - (P_u/P_{e1})} = \frac{0.915}{1 - \left(\frac{440}{6,055}\right)} = 0.99 < 1$$

Use  $B_1 = 1$

**K VALUES FOR BRACED FRAMES**

Figure 7.6 and the monographs in Figures 10.5 and 10.6 are used to determine the effective length factor,  $K$ . According to the AISC 360-10 commentary in Appendix 7, braced frames are commonly idealized as vertical cantilevered pin-connected truss systems. The effective length factor of components of a braced frame is normally taken as 1.

**BRACED FRAME DESIGN**

For braced frames only the magnification factor  $B_1$  is applied. As stated earlier, the use of an interaction equation, Equation 12.1 or 12.2, is direct in analysis when the member size is known. However, it is a trial-and-error procedure for designing a member.

Instead of making a blind guess, design aids are available to make a feasible selection prior to the application of the interaction equation. The procedure presented in the *AISC Manual 2010* for initial selection needs an intensive input of data from special tables included in the manual. In a previous version of the AISC manual, a different approach was suggested, which was less data intensive. This approach is described here.

The interaction equations can be expressed in terms of an equivalent axial load. With respect to Equation 12.1, this modification is demonstrated as follows:

$$\frac{P_u}{\phi P_n} + \frac{8}{9} \left( \frac{M_{ux}}{\phi_b M_{nx}} + \frac{M_{uy}}{\phi_b M_{ny}} \right) = 1$$

Multiplying both sides by  $\phi P_n$ ,

$$P_u + \frac{8}{9} \frac{\phi P_n}{\phi_b} \left( \frac{M_{ux}}{M_{nx}} + \frac{M_{uy}}{M_{ny}} \right) = \phi P_n \tag{12.10}$$

**TABLE 12.1**  
**Values of Factor  $m$**

$F_y$ $KL$ (ft.)	36 ksi							50 ksi						
	10	12	14	16	18	20	22 and over	10	12	14	16	18	20	22 and over
<b>First Approximation</b>														
All shapes	2.4	2.3	2.2	2.2	2.1	2.0	1.9	2.4	2.3	2.2	2.0	1.9	1.8	1.7
<b>Subsequent Approximations</b>														
W, S 4	3.6	2.6	1.9	1.6	—	—	—	2.7	1.9	1.6	1.6	—	—	—
W, S 5	3.9	3.2	2.4	1.9	1.5	1.4	—	3.3	2.4	1.8	1.6	1.4	1.4	—
W, S 6	3.2	2.7	2.3	2.0	1.9	1.6	1.5	3.0	2.5	2.2	1.9	1.8	1.5	1.5
W 8	3.0	2.9	2.8	2.6	2.3	2.0	2.0	3.0	2.8	2.5	2.2	1.9	1.6	1.6
W 10	2.6	2.5	2.5	2.4	2.3	2.1	2.0	2.5	2.5	2.4	2.3	2.1	1.9	1.7
W 12	2.1	2.1	2.0	2.0	2.0	2.0	2.0	2.0	2.0	2.0	1.9	1.9	1.8	1.7
W 14	1.8	1.7	1.7	1.7	1.7	1.7	1.7	1.8	1.7	1.7	1.7	1.7	1.7	1.7

*Note:* Values of  $m$  are for  $C_m=0.85$ . When  $C_m$  is any value other than 0.85, multiply the tabular value of  $m$  by  $C_m/0.85$ .

Treating  $\phi P_n$  as  $P_{eff}$ , this can be expressed as

$$P_{eff} = P_u + mM_{ux} + mUM_{uy} \quad (12.11)$$

where

$P_u$  is factored axial load

$M_{ux}$  is magnified factored moment about the  $x$  axis

$M_{uy}$  is magnified factored moment about the  $y$  axis

The values of the coefficient  $m$ , reproduced from the AISC manual, are given in Table 12.1.

The manual uses an iterative application of Equation 12.11 to determine the equivalent axial compressive load,  $P_{eff}$ , for which a member could be picked up as an axially loaded column only. However, this also requires the use of an additional table to select the value of  $U$ .

This chapter suggests an application of Equation 12.11 just to make an educated guess for a preliminary section. The initially selected section will then be checked by the interaction equations.

The procedure is as follows:

1. For the known value of effective length,  $KL$ , pickup the value of  $m$  from Table 12.1 for a selected column shape category. For example, for a column of W 12 shape to be used, for the computed  $KL$  of 16, the magnitude of  $m$  is 2 from Table 12.1.
2. Assume  $U = 3$  in all cases.
3. From Equation 12.11, solve for  $P_{eff}$ .
4. Pick up a section having cross-sectional area larger than the following:

$$A_g = \frac{P_{eff}}{\phi F_y}$$

5. Confirm the selection using the appropriate interaction equation, Equation 12.1 or Equation 12.2.

### Example 12.3

For a braced frame, the axial load and the end moments obtained from structural analysis are shown in Figure 12.7. Design a W14 member of A992 steel. Use  $K = 1$  for the braced frame.

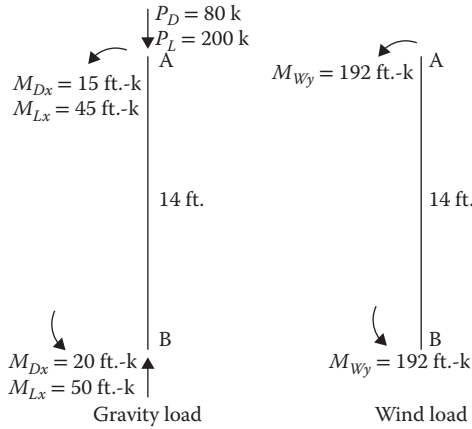


FIGURE 12.7 Column member of a braced frame.

**SOLUTION**

A. Critical load combinations

- a.  $1.2D + 1.6L$ 
  1. Assume a member weight of 100 lb/ft.; total weight =  $100(14) = 1400$  lb or 1.4 k
  2.  $P_u = 1.2(81.4) + 1.6(200) = 417.7$  k
  3.  $(M_{u1})_x$  at A =  $1.2(15) + 1.6(45) = 90$  ft.-k
  4.  $(M_{u1})_x$  at B =  $1.2(20) + 1.6(50) = 104$  ft.-k
- b.  $1.2D + L + W$ 
  1.  $P_u = 1.2(81.4) + 200 = 297.7$  k
  2.  $(M_{u1})_x$  at A =  $1.2(15) + 45 = 63$  ft.-k
  3.  $(M_{u1})_x$  at B =  $1.2(20) + 50 = 74$  ft.-k
  4.  $(M_{u1})_y = 192$  ft.-k

B. Trial selection

1. For load combination (a)
 

From Table 12.1 for  $KL = 14$  ft.,  $m = 1.7$

$$P_{eff} = 417.7 + 1.7(104) = 594.5$$
 k
2. For load combination (b), let  $U = 3$ 

$$P_{eff} = 297.7 + 1.7(74) + 1.7(3)(192) = 1402.7$$
 k ← controls

3.  $A_g = \frac{P_{eff}}{\phi F_y} = \frac{1402.7}{(0.9)(50)} = 31.17$  in.<sup>2</sup>

4. Select  $W14 \times 109$   $A = 32.0$  in.<sup>2</sup>
  - $Z_x = 192$  in.<sup>3</sup>
  - $Z_y = 92.7$  in.<sup>3</sup>
  - $r_x = 6.22$  in.
  - $r_y = 3.73$  in.
  - $b_f/2t_f = 8.49$
  - $h/t_w = 21.7$

Checking of the trial selection for load combination (b)

C. Along the strong axis

1. Moment strength
 
$$\phi M_{nx} = \phi F_y Z_x = 0.9(50)(192) = 8640$$
 in.-k or 720 ft.-k
2. Modification factor for magnification factor  $B_1$ : reverse curvature

$$\frac{(M_{nt})_x \text{ at A}}{(M_{nt})_x \text{ at B}} = \frac{63}{74} = 0.85$$

$$C_{mx} = 0.6 - 0.4(0.85) = 0.26$$

3. Magnification factor,  $B_1$

$$K = 1$$

$$\frac{KL}{r_x} = \frac{(1)(14 \times 12)}{6.22} = 27.0$$

$$(P_{e1})_x = \frac{\pi^2 EA}{(KL/r_x)^2} = \frac{\pi^2(29,000)(32)}{(27.0)^2} = 12,551$$

4.  $(B_1)_x = \frac{C_m}{1 - (P_u/P_{e1})}$

$$= \frac{0.26}{1 - (297.7/12,551)} = 0.27 < 1; \text{ use } 1$$

5.  $(M_u)_x = B_1(M_{u1})_x$   
 $= 1(74) = 74 \text{ ft}\cdot\text{k}$

D. Along the minor axis

1. Moment strength

$$\phi M_{ny} = \phi F_y Z_y = 0.9(50)(92.7) = 4171.5 \text{ in}\cdot\text{k or } 347.63 \text{ ft}\cdot\text{k}$$

2. Modification factor for magnification factor  $B_1$ : reverse curvature

$$\frac{(M_{u1})_x \text{ at A}}{(M_{u1})_x \text{ at B}} = \frac{192}{192} = 1$$

$$C_{mx} = 0.6 - 0.4(1) = 0.2$$

3. Magnification factor,  $B_1$

$$K = 1$$

$$\frac{KL}{r_y} = \frac{(1)(14 \times 12)}{3.73} = 45.0$$

$$(P_{e1})_y = \frac{\pi^2 EA}{(KL/r_y)^2} = \frac{\pi^2(29,000)(32)}{(45.0)^2} = 4,518.4$$

4.  $(B_1)_y = \frac{C_m}{1 - (P_u/P_{e1})}$

$$= \frac{0.2}{1 - (297.7/4518.4)} = 0.21 < 1; \text{ use } 1$$

5.  $(M_u)_y = (B_1)_y (M_{nt})_y$   
 $= 1(192) = 192 \text{ ft}\cdot\text{k}$

E. Compression strength

1.  $\frac{KL}{r_x} = \frac{(1)(14 \times 12)}{6.22} = 27.0$

2.  $\frac{KL}{r_y} = \frac{(1)(14 \times 12)}{3.73} = 45.0 \leftarrow \text{controls}$

3. Since  $4.71 \sqrt{\frac{E}{F_y}} = 4.71 \sqrt{\frac{29,000}{50}} = 113.43 > 45$ ; inelastic buckling

4.  $F_e = \frac{\pi^2 E}{(KL/r_y)^2} = \frac{\pi^2(29,000)}{(45.0)^2} = 141.2$

5.  $F_{cr} = (0.658^{50/141.2})50 = 43.11$

6.  $\phi P_n = 0.9 F_{cr} A_g$   
 $= 0.9(43.11)(32) = 1241.6 \text{ k}$

F. Interaction equation

$$\frac{P_u}{\phi P_n} = \frac{297.7}{1241.6} = 0.24 > 0.2$$

$$\frac{P_u}{\phi P_n} + \frac{8}{9} \left( \frac{M_{ux}}{\phi_b M_{nx}} + \frac{M_{uy}}{\phi_b M_{ny}} \right)$$

$$0.24 + \frac{8}{9} \left( \frac{74}{720} + \frac{192}{347.63} \right)$$

$$= 0.82 < 1 \quad \text{OK}$$

**MAGNIFICATION FACTOR FOR SWAY,  $B_2$**

The term  $B_2$  is used to magnify column moments under the sidesway condition. For sidesway to occur in a column on a floor, it is necessary that all of the columns on that floor should sway simultaneously. Hence, the total load acting on all columns on a floor appears in the expression for  $B_2$ . The *AISC Manual 2010* presents the following two relations for  $B_2$ :

$$B_2 = \frac{1}{1 - \frac{\sum P_u}{\Sigma H} \left( \frac{\Delta H}{L} \right)} \tag{12.12}$$

or

$$B_2 = \frac{1}{1 - \frac{\sum P_u}{\Sigma P_{e2}}} \tag{12.13}$$

where

- $\Delta H$  is lateral deflection of the floor (story) in question
- $L$  is story height
- $\Sigma H$  is sum of horizontal forces on the floor in question
- $\sum P_u$  is total design axial force on all the columns on the floor in question
- $\Sigma P_{e2}$  is summation of the elastic (Euler) capacity of all columns on the floor in question, given by

$$\Sigma P_{e2} = \Sigma \frac{\pi^2 EA}{(KL/r)^2} \tag{12.14}$$

The term  $P_{e2}$  is similar to the term  $P_{e1}$ , except that the factor  $K$  is used in the plane of bending for an unbraced condition in determining  $P_{e2}$  whereas  $K$  in  $P_{e1}$  is in the plane of bending for the braced condition.

A designer can use either Equation 12.12 or Equation 12.13; the choice is a matter of convenience. In Equation 12.12, initial size of the members is not necessary since  $A$  and  $r$  are not required as a part of  $P_{e2}$ , unlike in Equation 12.13. Further, a limit on  $\Delta H/L$ , known as the *drift index*, can be set by the designer to control the sway. This is limited to 0.004 with factored loads.

**K VALUES FOR UNBRACED FRAMES**

According to the AISC 360-10 commentary in Appendix 7 of that document, the lateral moment resisting frames generally have an effective length factor,  $K$ , greater than 1. However, when the sidesway amplification factor,  $B_2$ , is less than or equal to 1, the effective length factor  $K = 1$  can be used.

As stated in Chapter 10, for the unbraced frame the lower-story columns can be designed using  $K = 2$  for pin-supported bases and 1.2 for fixed bases. For upper-story columns,  $K = 1.2$ .

**Example 12.4**

An unbraced frame of A992 steel at the base floor level is shown in Figure 12.8. The loads are factored. Determine the magnification factor for sway for the column bending in the  $y$  axis.

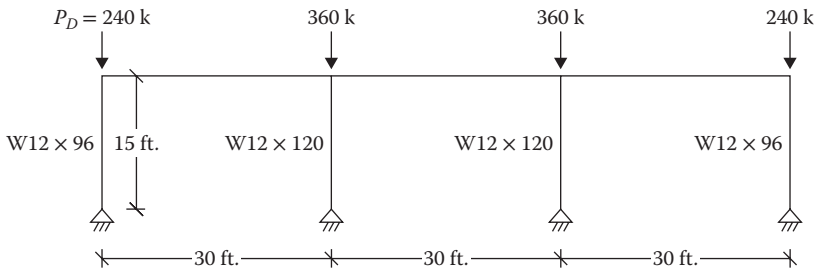


FIGURE 12.8 Unbraced frame for Example 12.4.

## SOLUTION

### A. Exterior columns

1. Factored weight of column =  $1.2(0.096 \times 15) = 1.7$  k
2.  $P_u = 240 + 1.7 = 241.7$  k
3.  $K = 2$
4. For W12 x 96,  $A = 28.2$  in.<sup>2</sup>  
 $r_y = 3.09$  in.
5.  $\frac{KL}{r_y} = \frac{2(15 \times 12)}{3.09} = 116.50$
6.  $P_{e2} = \frac{\pi^2 EA}{(KL/r_y)^2} = \frac{\pi^2(29,000)(28.2)}{(116.5)^2} = 594.1$  k

### B. Interior columns

1. Factored weight of column =  $1.2(0.12 \times 15) = 2.2$  k
2.  $P_u = 360 + 2.2 = 362.2$  k
3.  $K = 2$
4. For W12 x 120,  $A = 35.2$  in.<sup>2</sup>  
 $r_y = 3.13$  in.
5.  $\frac{KL}{r_y} = \frac{2(15 \times 12)}{3.13} = 115.0$
6.  $P_{e2} = \frac{\pi^2 EA}{(KL/r_y)^2} = \frac{\pi^2(290,000)(35.2)}{(115)^2} = 761$  k

### C. For the entire story

1.  $\Sigma P_u = 2(241.7) + 2(362.2) = 1208$  k
2.  $\Sigma P_{e2} = 2(594.1) + 2(761) = 2710$  k
3. From Equation 12.13

$$B_2 = \frac{1}{1 - \left( \frac{\Sigma P_u}{\Sigma P_{e2}} \right)}$$

$$= \frac{1}{1 - \left( \frac{1208}{2710} \right)} = 1.80$$

## Example 12.5

In Example 12.4, the total factored horizontal force on the floor is 200 k and the allowable drift index is 0.002. Determine the magnification factor for sway.

**SOLUTION**

From Equation 12.12

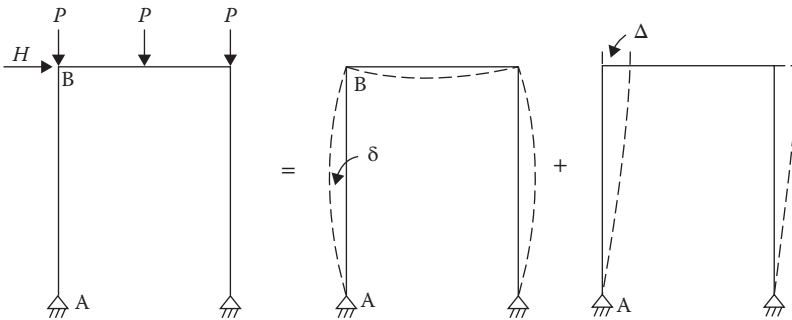
$$B_2 = \frac{1}{1 - \frac{\sum P_u}{\sum H} \left( \frac{\Delta H}{L} \right)} = \frac{1}{1 - \left( \frac{1208}{200} \right) (0.002)} = 1.01$$

**UNBRACED FRAME DESIGN**

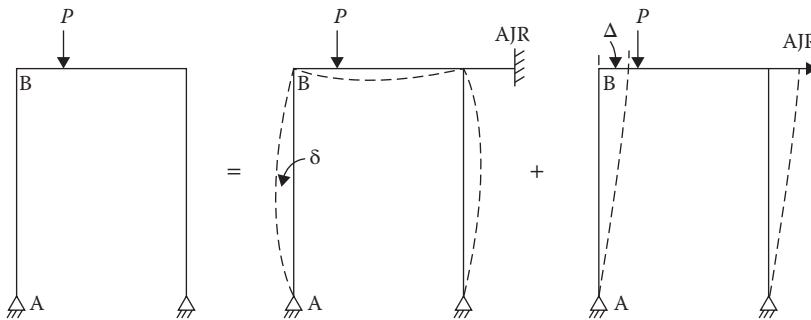
The interaction Equations 12.1 and 12.2 are used for unbraced frame design as well.  $M_{ux}$  and  $M_{uy}$  in the equations are computed by Equation 12.6 magnified for both  $B_1$  and  $B_2$ .

The trial size can be determined from Equation 12.11 following the procedure stated in the “Braced Frame Design” section. When an unbraced frame is subjected to symmetrical vertical (gravity) loads along with a lateral load, as shown in Figure 12.9, the moment  $M_{u1}$  in member AB is computed for the gravity loads. This moment is amplified by the factor  $B_1$  to account for the  $P-\delta$  effect. The moment  $M_{u2}$  is computed due to the horizontal load  $H$ . It is then magnified by the factor  $B_2$  for the  $P-\Delta$  effect.

When an unbraced frame supports an asymmetric loading, as shown in Figure 12.10, the eccentric loading causes it to deflect sideways. First, the frame is considered to be braced by a fictitious support called an *artificial joint restraint* (AJR). The moment  $M_{u1}$  and the deflection  $\delta$  are computed, which is amplified by the factor  $B_1$ .



**FIGURE 12.9** Symmetrical vertical loads and a lateral load on an unbraced frame.



**FIGURE 12.10** Asymmetric loading on an unbraced frame: AJR, artificial joint restraint.

To compute  $M_{u2}$ , a force equal to AJR but opposite in direction is then applied. This moment is magnified by the factor  $B_2$  for the  $P-\Delta$  effect.

When both asymmetric gravity loads and lateral loads are present, the aforementioned two cases are combined, that is, AJR force is added to the lateral loads to compute  $M_{u2}$  for the  $P-\Delta$  effect.

Alternatively, two structural analyses are performed. The first analysis is performed as a braced frame; the resulting moment is  $M_{u1}$ . The second analysis is done as an unbraced frame. The results of the first analysis are subtracted from those of the second analysis to obtain  $M_{u2}$ .

### Example 12.6

An unbraced frame of A992 steel is subjected to the dead load, live load, and wind load. The structural analysis provides the axial forces and the moments on the column along the  $x$  axis, as shown in Figure 12.11. Design for a maximum drift of 0.5 in.

## SOLUTION

### A. Critical load combinations

#### a. $1.2D + 1.6L$

1. Assume a member weight of 100 lb/ft., total weight = 100(15) = 1500 lb or 1.5 k
2.  $P_u = 1.2(81.5) + 1.6(210) = 433.8$  k
3.  $(M_{u1})_x$  at A = 1.2(15) + 1.6(45) = 90 ft.-k
4.  $(M_{u1})_x$  at B = 1.2(20) + 1.6(50) = 104 ft.-k
5.  $(M_{u2}) = 0$  since the wind load is not in this combination

#### b. $1.2D + L + W$

1.  $P_u = 1.2(81.5) + 210 = 307.8$  k
2.  $(M_{u1})_x$  at A = 1.2(15) + 45 = 63 ft.-k
3.  $(M_{u1})_x$  at B = 1.2(20) + 50 = 74 ft.-k
4.  $(M_{u2})_x$  at A = 160 ft.-k
5.  $(M_{u2})_x$  at B = 160 ft.-k

### B. Trial selection

1. For load combination (a)  
Fixed base,  $K = 1.2$ ,  $KL = 1.2(15) = 18$  ft.  
From Table 12.1 for W12 section,  $m = 1.9$   
 $P_{eff} = 433.8 + 1.9(104) = 631.4$  k
2. For load combination (b)  
 $P_{eff} = 307.8 + 1.9(74) + 1.9(160) = 752.4$  k ← controls
3.  $A_g = \frac{P_{eff}}{\phi F_y} = \frac{751.4}{(0.9)(50)} = 16.7$
4. Select W12 × 72 (W12 × 65 has the noncompact flange)  
 $A = 21.1$  in.<sup>2</sup>  
 $Z_x = 108$  in.<sup>3</sup>  
 $r_x = 5.31$  in.

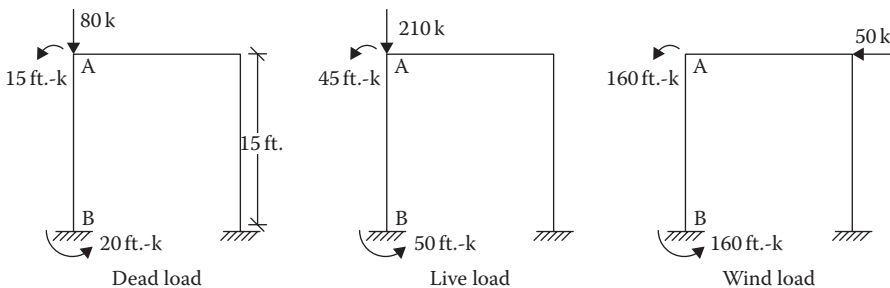


FIGURE 12.11 Loads on an unbraced frame.



$$r_y = 3.04 \text{ in.}$$

$$b_f/2t_f = 8.99$$

$$h/t_w = 22.6$$

Checking of the trial selection for critical load combination (b)

C. Moment strength

1.  $0.38 \sqrt{\frac{E}{F_y}} = 9.15 > \frac{b_f}{2t_f}$ , compact
2.  $3.76 \sqrt{\frac{E}{F_y}} = 90.55 > \frac{h}{t_w}$ , compact
3.  $\phi M_{nx} = \phi F_y Z_x = 0.9(50)(108) = 4860 \text{ in.-k}$  or 405 ft.-k

D. Modification factor for magnification factor  $B_1$ : reverse curvature

1.  $\frac{(M_{u1})_x \text{ at A}}{(M_{u1})_x \text{ at B}} = \frac{63}{74} = 0.85$
2.  $C_{mx} = 0.6 - 0.4(0.85) = 0.26$

E. Magnification factor,  $B_1$

1.  $K = 1$  for braced condition
2.  $\frac{KL}{r_x} = \frac{(1)(15 \times 12)}{5.31} = 33.9$
3.  $(P_{e1})_x = \frac{\pi^2 EA}{(KL/r_x)^2} = \frac{\pi^2(29,000)(21.1)}{(33.9)^2} = 5250$
4.  $(B_1)_x = \frac{C_m}{1 - \frac{P_u}{(P_{e1})_x}}$   
 $= \frac{0.26}{1 - \left(\frac{307.8}{5250}\right)} = 0.28 < 1$ ; use 1

F. Magnification factor for sway,  $B_2$

1.  $K = 1.2$  for unbraced condition
2.  $\frac{KL}{r_x} = \frac{(12)(15 \times 12)}{5.31} = 40.68$
3.  $(P_{e2})_x = \frac{\pi^2 EA}{(KL/r_x)^2} = \frac{\pi^2(29,000)(21.1)}{(40.68)^2} = 3,645.7$
4.  $\Sigma P_u = 2(307.8) = 615.6 \text{ k}$ , since there are two columns in the frame
5.  $\Sigma (P_{e2})_x = 2(3645.7) = 7291.4 \text{ k}$
6.  $\frac{H}{L} = \frac{0.5}{15 \times 12} = 0.00278$
7. From Equation 12.12

$$B_2 = \frac{1}{1 - \frac{\Sigma P_u \left(\frac{\Delta H}{L}\right)}{\Sigma H}}$$

$$= \frac{1}{1 - \left(\frac{615.6}{50}\right)(0.00278)} = 1.035$$

8. From Equation 12.13

$$B_2 = \frac{1}{1 - \frac{\Sigma P_u}{\Sigma P_{e2}}}$$

$$= \frac{1}{1 - \left(\frac{615.6}{7291.4}\right)} = 1.09 \leftarrow \text{controls}$$

G. Design moment

$$(M_u)_x = B_1(M_{u1})_x + B_2(M_{u2})_x \\ = 1(74) + 1.09(160) = 248.4 \text{ ft.-k}$$

H. Compression strength

$$1. \frac{KL}{r_x} = \frac{(1.2)(15 \times 12)}{5.31} = 40.7$$

$$2. \frac{KL}{r_y} = \frac{(1.2)(15 \times 12)}{3.04} = 71.05 \leftarrow \text{controls}$$

$$3. 4.71 \sqrt{\frac{E}{F_y}} = 4.71 \sqrt{\frac{29,000}{50}} = 113.43 > 71.05, \text{ inelastic buckling}$$

$$4. F_e = \frac{\pi^2 E}{(KL/r_y)^2} = \frac{\pi^2 (29,000)}{(71.05)^2} = 56.64$$

$$5. F_{cr} = (0.658^{50/56.64}) 50 = 34.55 \text{ ksi}$$

$$6. \phi P_n = 0.9 F_{cr} A_g \\ = 0.9(34.55)(21.1) = 656.2 \text{ k}$$

I. Interaction equation

$$1. \frac{P_u}{\phi P_n} = \frac{307.8}{656.2} = 0.47 > 0.2, \text{ apply Equation 12.1}$$

$$2. \frac{P_u}{\phi P_n} + \frac{8}{9} \left( \frac{M_{ux}}{\phi_b M_{nx}} \right) = 0.47 + \frac{8}{9} \left( \frac{248.4}{405} \right) \\ = 1.0 \quad \text{OK (border case)}$$

Select a W12 × 72 section.

## OPEN-WEB STEEL JOISTS

A common type of floor system for small- to medium-sized steel frame buildings consists of open-web steel joists with or without joist girders. Joist girders, when used, are designed to support open-web steel joists. Floor and roof slabs are supported by open-web joists. A typical plan is shown in Figure 12.12.

Open-web joists are parallel chord trusses where web members are made from steel bars or small angles. A section is shown in Figure 12.13. Open-web joists are pre-engineered systems that can be quickly erected. The open spaces in the web can accommodate ducts and piping.

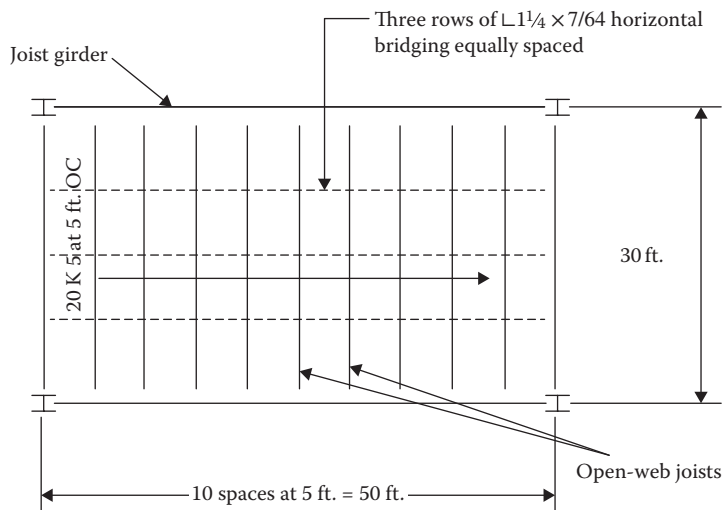


FIGURE 12.12 An open-web joist floor system.

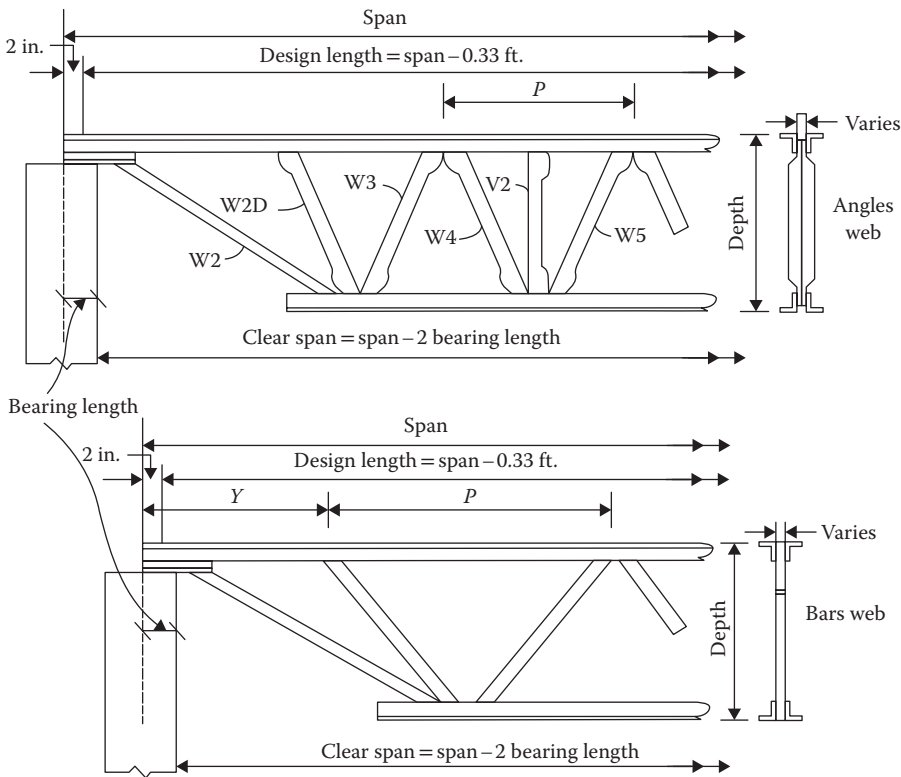


FIGURE 12.13 Open-web steel joist.

The AISC specifications do not cover open-web joists. A separate organization, the Steel Joist Institute (SJI), is responsible for the specifications related to open-web steel joists and joist girders. The SJI’s publication titled *Standard Specifications* deals with all aspects of open-web joists, including their design, manufacture, application, erection, stability, and handling.

Three categories of joists are presented in the standard specifications:

1. Open-web joists, K-series  
For span range 8–60 ft., depth 8–30 in., chords  $F_y = 50$  ksi, and web  $F_y = 36$  or 50 ksi
2. Long span steel joists, LH-series  
For span range 21–96 ft., depth 18–48 in., chords  $F_y = 36$  or 50 ksi, and web  $F_y = 36$  or 50 ksi
3. Deep long span joists, DLH-series  
For span range 61–144 ft., depth 52–72 in., chords  $F_y = 36$  or 50 ksi, and web  $F_y = 36$  or 50 ksi

Open-web joists use a standardized designation, for example, “18 K 6” means that the depth of the joist is 18 in. and it is a K-series joist that has a relative strength of 6. The higher the strength number, the stronger the joist. Different manufactures of 18 K 6 joists can provide different member cross sections, but they all must have a depth of 18 in. and a load capacity as tabulated by the SJI.

The joists are designed as simply supported uniformly loaded trusses supporting a floor or a roof deck. They are constructed so that the top chord of a joist is braced against lateral buckling.

The SJI specifications stipulate the following basis of design:

1. The bottom chord is designed as an axially loaded tensile member. The design standards and limiting states of Chapter 9 for tensile members are applied.
2. The top chord is designed for axial compression forces only when the panel length,  $l$ , does not exceed 24 in., which is taken as the spacing between lines of bridging. The design is

done according to the standards of Chapter 10 on columns. When the panel length exceeds 24 in., the top chord is designed as a continuous member subject to the combined axial compression and bending, as discussed in this chapter.

3. The web is designed for the vertical shear force determined from a full uniform loading, but it should not be less than one-fourth of the end reaction. The combined axial compression and bending is investigated for the compression web members.
4. Bridging comprising a cross-connection between adjoining joists is required for the top and bottom chords. This consists of one or both of the following types:
  - a. Horizontal bridging by a continuous horizontal steel member: the ratio of the length of bracing between the adjoining joists to the least radius of gyration,  $l/r$ , should not exceed 300.
  - b. Diagonal bridging by cross bracing between the joists with the  $l/r$  ratio determined on the basis of the length of the bracing and its radius of gyration not exceeding 200.

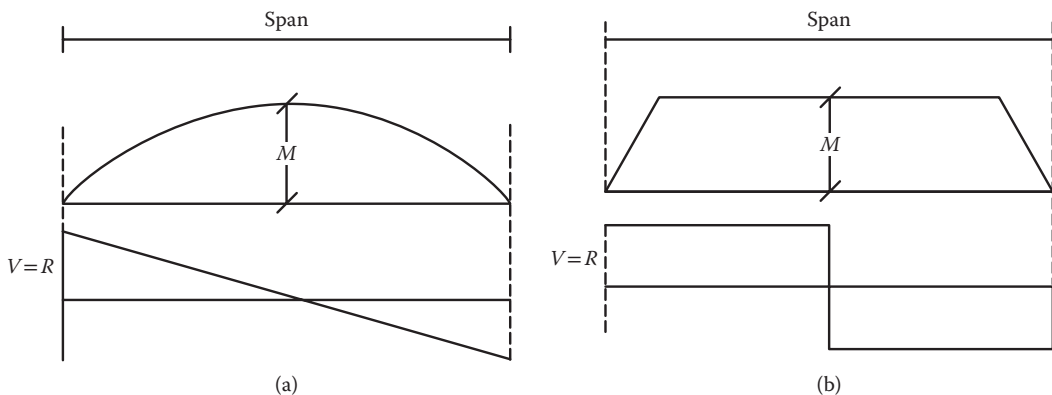
The number of rows of top chord and bottom chord bridging should not be less than that prescribed in the bridging tables of SJI standards. The spacing should be such that the radius of gyration of the top chord about its vertical axis should not be less than  $l/145$ , where  $l$  is the spacing in inches between the lines of bridging.

For design convenience, the SJI in its standard specifications has included the standard load tables that can be directly used to determine joist size. Tables for K-series joists are included in Appendix C, Table C.10 a and b. The loads in the tables represent the uniformly distributed loads. The joists are designed for a simple span uniform loading, which produces a parabolic moment diagram for the chord members and a linearly sloped (triangular shaped) shear diagram for the web members, as shown in Figure 12.14a.

To address the problem of supporting the uniform loads together with the concentrated loads, special K-series joists, known as KCS joists, are designed. KCS joists are designed for flat moments and rectangular shear envelopes, as shown in Figure 12.14b.

As an example, in Appendix C, Table C.10 a and b, under the column “18 K 6,” across a row corresponding to the joist span, the first figure is the total pounds per foot of load that an 18 K 6 joist can support and the second light-faced figure is the unfactored live load from the consideration of  $L/360$  deflection. For a live load deflection of  $L/240$ , multiply the load figure by the ratio  $360/240$ , that is, 1.5.

Example 12.7 demonstrates the use of the joist table.



**FIGURE 12.14** Shear and moment envelopes: (a) standard joist shear and bending moment diagrams and (b) KCS joist shear and bending moment diagrams.

**Example 12.7**

Select an open-web steel joist for a span of 30 ft. to support a dead load of 35 psf and a live load of 40 psf. The joist spacing is 4 ft. The maximum live load deflection is  $L/240$ .

**SOLUTION**

- A. Design loads
1. Tributary area per foot = 4 ft.<sup>2</sup>/ft.
  2. Dead load per foot =  $35 \times 4 = 140$  lb/ft.
  3. Weight of joist per foot = 10 lb/ft.
  4. Total dead load = 150 lb/ft.
  5. Factored dead load =  $1.2(150) = 180$  lb/ft.
  6. Live load per foot =  $40 \times 4 = 160$  lb/ft.
  7. Factored live load =  $1.6(160) = 256$  lb/ft.
  8. Total factored load = 436 lb/ft.
- B. Standard load table at Appendix C, Table C.10 a and b (from the table for joists starting at size 18 K 3)
1. Check the row corresponding to span 30. The section suitable for a total factored load of 436 lb/ft. is 18 K  $\times$  6, which has a capacity of 451 lb/ft.
  2. Live load capacity for  $L/240$  deflection
 
$$= \frac{360}{240}(175) = 262.5 \text{ lb/ft.} > 256 \text{ lb/ft. OK}$$
  3. The joists of a different depth might be designed by selecting a joist of another size from the standard load table of SJI (from the table starting at size 8 K 1). In fact, SJI includes an economy table for the lightest joist selection.

**JOIST GIRDERS**

The loads on a joist girder are applied through open-web joists that the girder supports. This load is equal in magnitude and evenly spaced along the top chord of the girder applied through the panel points.

The bottom chord is designed as an axially loaded tension member. The radius of gyration of the bottom chord about its vertical axis should not be less than  $l/240$ , where  $l$  is the distance between the lines of bracing.

The top chord is designed as an axially loaded compression member. The radius of gyration of the top chord about the vertical axis should not be less than  $\text{span}/575$ .

The web is designed for vertical shear for full loading but should not be less than one-fourth of the end reaction. The tensile web members are designed to resist at least 25% of the axial force in compression.

The SJI, in its standard specifications, has included the girder tables that are used to design girders. Selected tables have been included in Appendix C, Table C.11. The following are the design parameters of a joist girder:

1. Span of the girder.
2. Number of spacings or size (distance) of spacings of the open-web joists on the girder: when the spacing size is known, the number equals the span/size of spacing; for the known number of spacings, size equals the span/number.
3. The point load on the panel points in kips: total factored unit load in pounds per square foot is multiplied by the spacing size and the length of the joist (joist span or bay length) converted to kips.
4. Depth of girder.

For any of the first three known parameters, the fourth one can be determined from the girder tables. In addition, the table gives the weight of the girder in pounds per foot to confirm that it has been adequately included in the design loads.

Usually, the first three parameters are known and the depth of the girder is determined. A rule of thumb is about an inch of depth for each feet of span for an economic section. Each joist girder uses a standardized designation; for example, “36G 8N 15F” means that the depth of the girder is 36 in., it provides for eight equal joist spaces, and it supports a factored load of 15 k at each panel location (a symbol K at the end, in place of F, is used for the service load capacity at each location).

### Example 12.8

Specify the size of the joist girder for the floor system shown in Figure 12.15.

### SOLUTION

#### A. Design loads

1. Including 1 psf for the weight of the girder, total factored load  
 $= 1.2(15 + 1) + 1.6(30) = 67.2$  psf
2. Panel area =  $6 \times 20 = 120$  ft.<sup>2</sup>
3. Factored concentrated load/panel point  
 $= 67.2 \times 120 = 8064$  lb or 8.1k, use 9 k

#### B. Joist details

1. Space size = 6 ft.
2. Number spaces =  $\frac{30}{6} = 5$

#### C. Girder depth selection

1. Refer to Appendix C, Table C.11. For 30 ft. span, 5 N, and 9 k load, the range of depth is 24–36 in.  
 Select 28G 5N 9F.
2. From Appendix C, Table C.11, weight per foot of girder = 17 lb/ft.  
 Unit weight =  $\frac{17}{20} = 0.85$  psf < assumed 1 psf **OK**
3. The information shown in Figure 12.16 will be specified to the manufacturer.

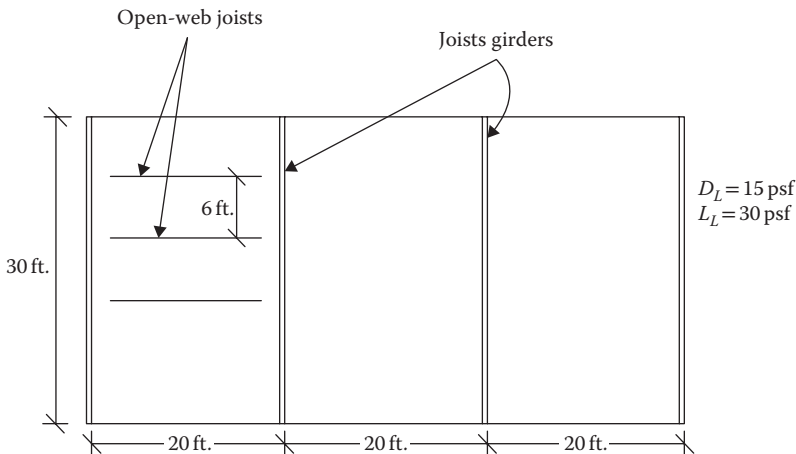


FIGURE 12.15 Floor system for Example 12.8.

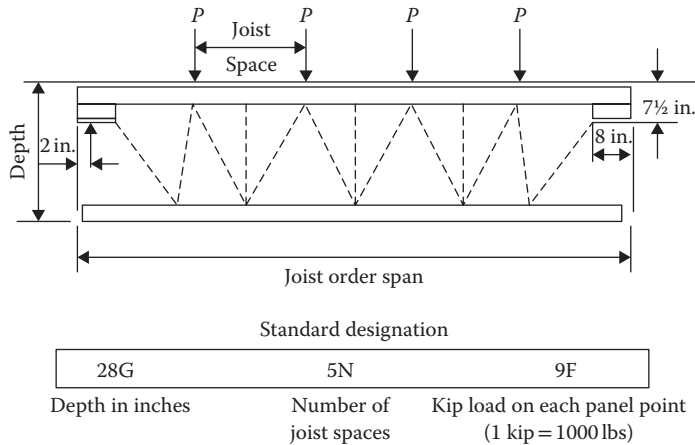


FIGURE 12.16 Selection of joist girder.

**PROBLEMS**

**Note:** In all problems assume the full lateral support conditions.

- 12.1 A W12×35 section of A992 steel with a single line (along the tensile force) of four 3/4 in. bolts in the web is subjected to a tensile live load of 65 k and a bending moment only due to the dead load including the weight of the member along the weak axis of 20 ft.-k. Is this member satisfactory?
- 12.2 A W10×33 member is to support a factored tensile force of 100 k and a factored moment along the *x* axis of 100 ft.-k including the weight of member. It is a fully welded member of grade 50 steel. Is the member adequate for the loads?
- 12.3 A 12 ft. long hanger supports a tensile dead load of 50 k and a live load of 100 k at an eccentricity of 4 in. with respect to the *x* axis. Design a W10 section of A992 steel. There is one line of three bolts of 3/4 in. diameter on one side of the top flange and one line of three bolts of the same size on the other side of the top flange. The bottom flange has a bolt pattern similar to the top flange.
- 12.4 Design a W8 or W10 member to support the loads shown in Figure P12.1. It has a single line of four holes for 7/8 in. bolts in the web. The member consists of A992 steel.
- 12.5 The member in Problem 12.4, in addition to the loading along the *x* axis, has a factored bending moment of 40 ft.-k along the *y* axis. Design the member.  
[Hint: Since a sizeable bending along the *y* axis is involved, initially select a section at least four times of that required for axial load alone.]
- 12.6 A horizontal beam section W10×26 of A992 steel is subjected to the service live loads shown in Figure P12.2. The member is bent about the *x* axis. Determine the magnitude of the magnification factor  $B_1$ .
- 12.7 A braced frame member W12×58 of A992 steel is subjected to the loads shown in Figure P12.3. The member is bent about the *x* axis. Determine the magnitude of the magnification factor  $B_1$ . Assume pin-end conditions.
- 12.8 In Problem 12.7, the moments at the ends A and B are both clockwise. The ends are restrained (fixed). Determine the magnification factor  $B_1$ .
- 12.9 In Problem 12.7, in addition to the loads shown a uniformly distributed wind load of 1 k/ft. acts laterally between A and B. Determine the magnification factor  $B_1$ .

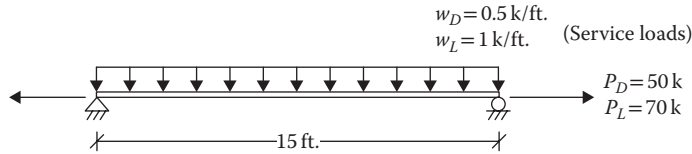


FIGURE P12.1 Tensile and flexure member for Problem 12.4.

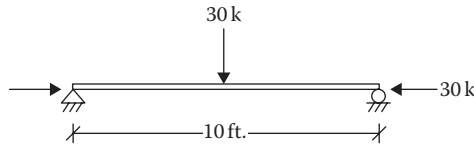


FIGURE P12.2 Compression flexure member for Problem 12.6.

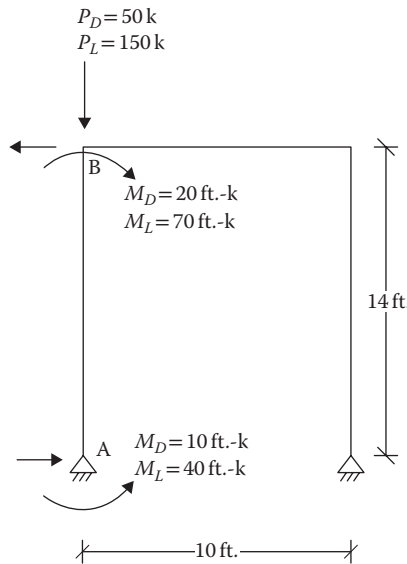


FIGURE P12.3 Braced frame member for Problem 12.7.

12.10 In Problem 12.7, in addition to the shown  $x$ -axis moments, the moments in the  $y$  axis at A and B are as follows. Determine the magnification factor  $B_1$ .

At B ( $M_D$ )<sub>y</sub> = 10 ft.-k, ( $M_L$ )<sub>y</sub> = 20 ft.-k, both clockwise

At A ( $M_D$ )<sub>y</sub> = 8 ft.-k, ( $M_L$ )<sub>y</sub> = 15 ft.-k, both counterclockwise

12.11 The member of a A572 steel section, as shown in Figure P12.4, is used as a beam column in a braced frame. It is bent about the strong axis. Is the member adequate?

12.12 A horizontal component of a braced frame is shown in Figure P12.5. It is bent about the strong axis. Is the member adequate? Use A992 steel.

12.13 The member of a A572 steel section, as shown in Figure P12.6, is used as a beam column in a braced frame. It has restrained ends. Is the member adequate?



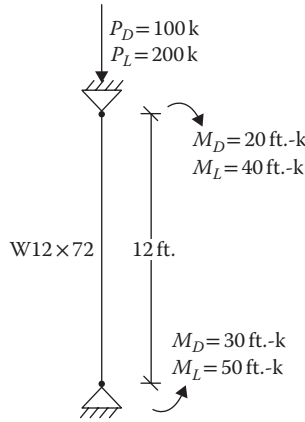


FIGURE P12.4 Beam-column member for Problem 12.11.

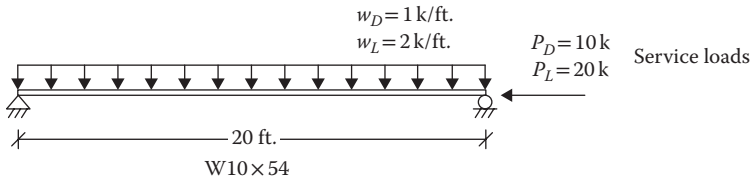


FIGURE P12.5 Horizontal component of a braced frame for Problem 12.12.

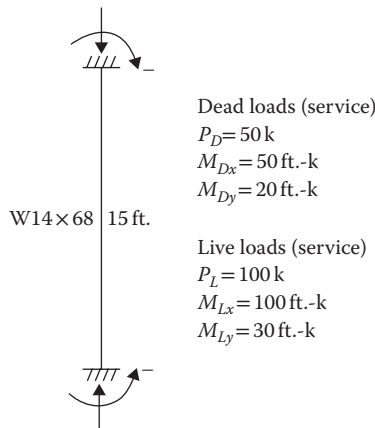


FIGURE P12.6 Restrained braced frame member for Problem 12.13.

- 12.14 A  $W12 \times 74$  section of A572 steel is part of a braced frame. It is subjected to service, dead, live, and seismic loads, as shown in Figure P12.7. The bending is along the strong axis. It has pinned ends. Is the section satisfactory?
- 12.15 For a braced frame, the service axial load and the moments obtained by structural analysis are shown in Figure P12.8. Design a W14 section of A992 steel. One end is fixed, and the other is hinged.
- 12.16 In Problem 12.15, the gravity dead and live loads and moments act along the  $x$  axis and the wind load moments act along the  $y$  axis (instead of the  $x$  axis). Design the member.

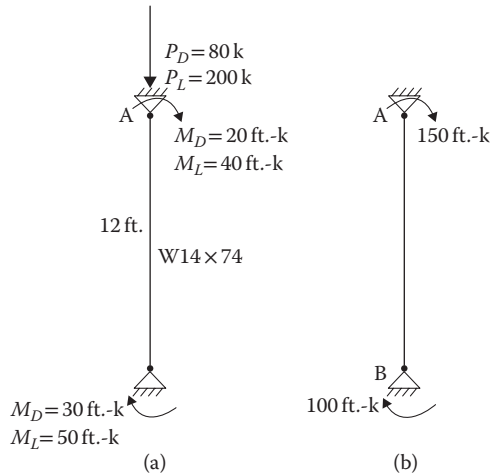


FIGURE P12.7 (a) Gravity and (b) seismic loads on a braced frame.

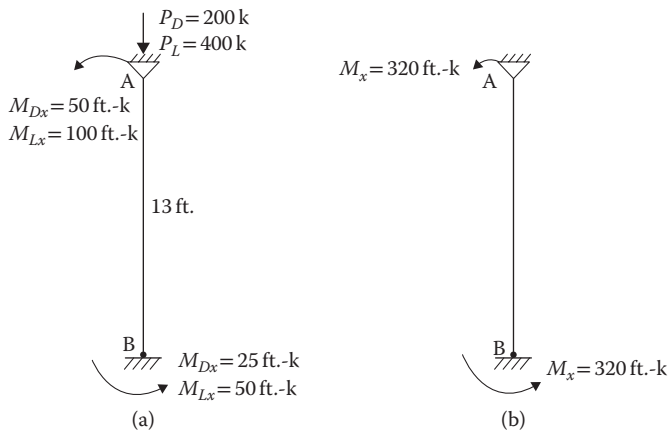


FIGURE P12.8 (a) Gravity and (b) wind loads on a braced frame.

- 12.17** For a 12 ft. high beam column in an unbraced A36 steel frame, a section  $W10 \times 88$  is selected for  $P_u = 500$  k. There are five columns of the same size bearing the same load and having the same buckling strength. Assume that the members are fixed at the support in the  $x$  direction and hinged at the support in the  $y$  direction and are free to sway (rotation is fixed) at the other end in both directions. Determine the magnification factors in both directions.
- 12.18** In Problem 12.17, the drift along the  $x$  axis is 0.3 in. as a result of a factored lateral load of 300 k. Determine the magnification factor  $B_2$ .
- 12.19** An unbraced frame of A992 steel is shown in Figure P12.9. Determine the magnification factors along both axes for exterior columns.
- 12.20** The allowable story drift in Problem 12.19 is 0.5 in. in the  $x$  direction. Determine the magnification factor  $B_2$  along  $x$  axis for exterior columns.
- 12.21** A 10 ft. long  $W12 \times 96$  column of A992 steel in an unbraced frame is subjected to the following factored loads. Is the section satisfactory?
- $P_u = 240$  k ( $M_{u1}$ ) <sub>$x$</sub>  = 50 ft.-k ( $M_{u1}$ ) <sub>$y$</sub>  = 30 ft.-k ( $M_{u2}$ ) <sub>$x$</sub>  = 100 ft.-k ( $M_{u2}$ ) <sub>$y$</sub>  = 70 ft.-k
  - It is bent in reverse curvature with equal and opposite end moments.
  - There are five similar columns in a story.
  - The column is fixed at the base and is free to translate without rotation at the other end.

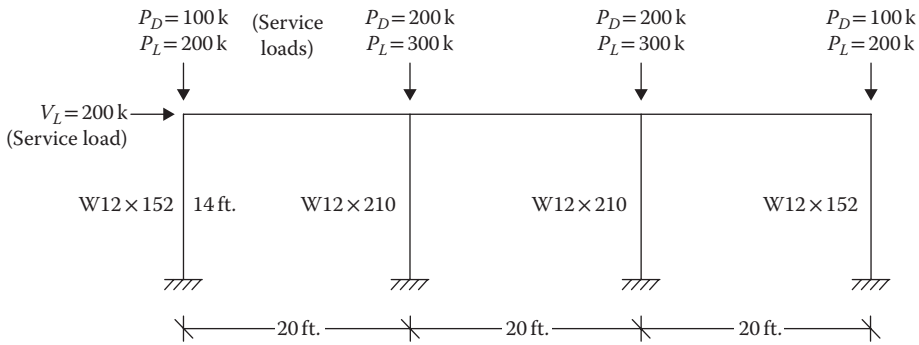


FIGURE P12.9 Unbraced frame for Problem 12.19.

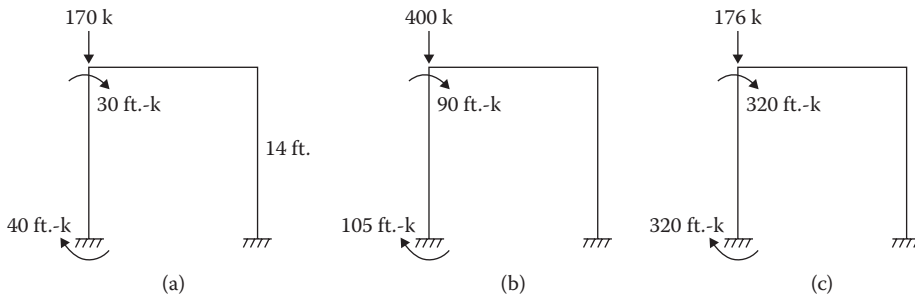
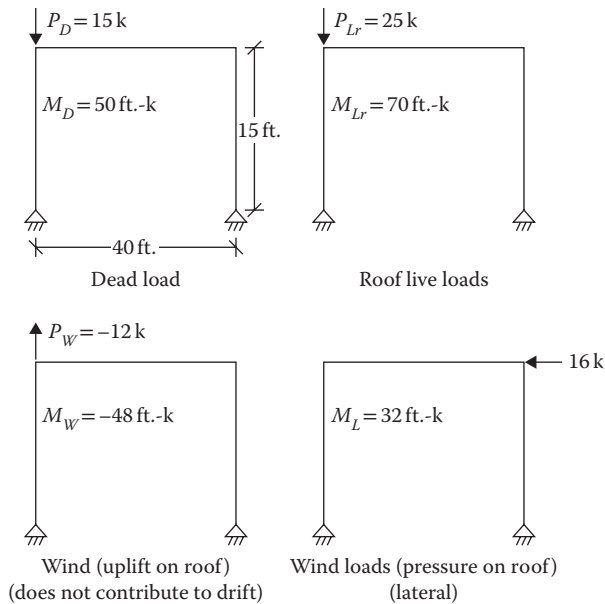


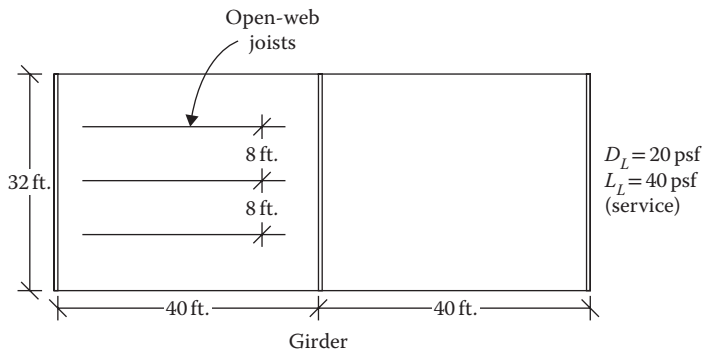
FIGURE P12.10 (a) Dead, (b) live, and (c) wind loads on the unbraced frame for Problem 12.23.

**12.22** Select a W12 column member of A992 steel of an unbraced frame for the following conditions; all loads are factored:

1.  $K = 1.2$  for the sway case and  $K = 1$  for the unsway case
  2.  $L = 12$  ft.
  3.  $P_u = 350$  k
  4.  $(M_{u1})_x = 75$  ft.-k
  5.  $(M_{u1})_y = 40$  ft.-k
  6.  $(M_{u2})_x = 150$  ft.-k
  7.  $(M_{u2})_y = 80$  ft.-k
  8. Allowable drift = 0.3 in.
  9. It has intermediate transverse loading between the ends.
  10. Total factored horizontal force = 100 k
  11. There are four similar columns in a story.
- 12.23** An unbraced frame of A992 steel is subjected to dead, live, and wind loads in the  $x$  axis; the wind load causes the sway. Structural analysis provided the loads as shown in Figure P12.10. Design a W14 section for a maximum drift of 0.5 in. Each column is subjected to the same axial force and moment.
- 12.24** A one-story unbraced frame of A992 steel is subjected to dead, roof live, and wind loads. The bending is in the  $x$  axis. Structural analysis provided the loads as shown in Figure P12.11. The moments at the base are 0. Design a W12 section for a maximum drift of 0.5 in. The lateral wind load causes the sway.
- 12.25** Select a K-series open-web steel joist spanning 25 ft. to support a dead load of 30 psf and a live load of 50 psf. The joist spacing is 3.5 ft. The maximum live load deflection is  $L/360$ .



**FIGURE P12.11** Dead, roof live, and wind loads on the unbraced frame for Problem 12.24.



**FIGURE P12.12** Open-web joist and joist girder floor system for Problem 12.29.

**12.26** Select an open-web steel joist for the following flooring system:

1. Joist spacing: 3 ft.
2. Span length: 20 ft.
3. Floor slab: 3 in. concrete
4. Other dead load: 30 psf
5. Live load: 60 psf
6. Maximum live load deflection:  $L/240$

**12.27** On an 18 K 10 joist spanning 30 ft., how much total unit load and unfactored live load in pounds per square foot can be imposed? The joist spacing is 4 ft. The maximum live load deflection is  $L/300$ .

**12.28** The service dead load in pounds per square foot on an 18 K 6 joist is one-half of the live load. What are the magnitudes of these loads on the joist loaded to the capacity at a span of 20 ft., spaced 4 ft. on center?

**12.29** Indicate the joist girder designation for the flooring system shown in Figure P12.12.

**12.30** For a 30 ft.  $\times$  50 ft. bay, joists spaced 3.75 ft. on center, indicate the designation of the joist girders to be used for a dead load of 20 psf and a live load of 30 psf.

---

# 13 Steel Connections

## TYPES OF CONNECTIONS AND JOINTS

Most structures' failure occurs at a connection. Accordingly, the American Institute of Steel Construction (AISC) has placed a lot of emphasis on connections and has brought out separate detailed design specifications related to connections in the *2005 Steel Design Manual*. Steel connections are made by bolting and welding; riveting is obsolete now. Bolting of steel structures is rapid and requires less skilled labor. On the other hand, welding is simple and many complex connections with bolts become very simple when welds are used. But the requirements of skilled workers and inspections make welding difficult and costly, which can be partially overcome by shop welding instead of field welding. When a combination is used, welding can be done in the shop and bolting in the field.

Based on the mode of load transfer, the connections are categorized as follows:

1. Simple or axially loaded connection when the resultant of the applied forces passes through the center of gravity of the connection
2. Eccentrically loaded connection when the line of action of the resultant of the forces does not pass through the center of gravity of the connection

The following types of joints are formed by the two connecting members:

1. *Lap joint*: As shown in Figure 13.1, the line of action of the force in one member and the line of action of the force in the other connecting member have a gap between them. This causes a bending within the connection, as shown by the dashed lines. For this reason, the lap joint is used for minor connections only.
2. *Butt joint*: This provides a more symmetrical loading, as shown in Figure 13.2, that eliminates the bending condition.

The connectors (bolts or welds) are subjected to the following types of forces (and stresses):

1. *Shear*: The forces acting on the splices shown in Figure 13.3 can shear the shank of the bolt. Similarly, the weld in Figure 13.4 resists the shear.
2. *Tension*: The hanger-type connection shown in Figures 13.5 and 13.6 imposes tension in bolts and welds.
3. *Shear and tension combination*: The column-to-beam connections shown in Figures 13.7 and 13.8 cause both shear and tension in bolts and welds. The welds are weak in shear and are usually assumed to fail in shear regardless of the direction of the loading.

## BOLTED CONNECTIONS

The ordinary or common bolts, also known as *unfinished bolts*, are classified as A307 bolts. The characteristics of A307 steel are very similar to A36 steel. Their strength is considerably less than those of high-strength bolts. Their use is recommended for structures subjected to static loads and for the secondary members like purlins, girts, and bracings. With the advent of high-strength bolts, the use of the ordinary bolts has been neglected, although for ordinary construction, the common bolts are quite satisfactory.

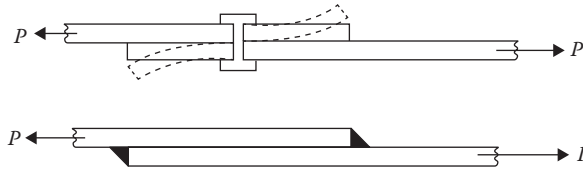


FIGURE 13.1 Lap joint.

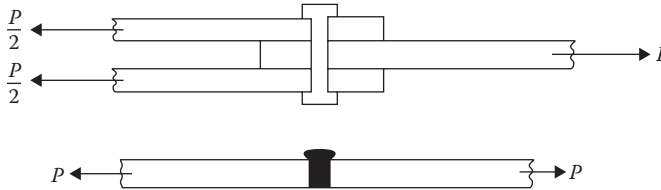


FIGURE 13.2 Butt joint.

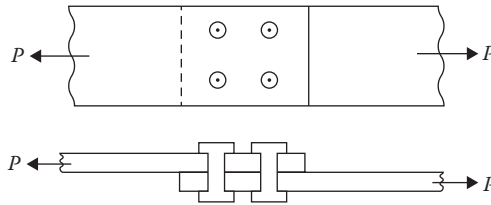


FIGURE 13.3 Bolts in shear.

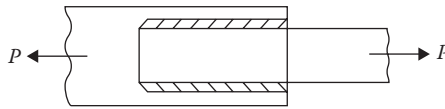


FIGURE 13.4 Welds in shear.

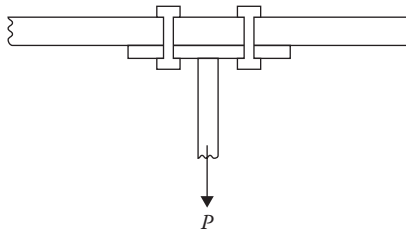


FIGURE 13.5 Bolts in tension.

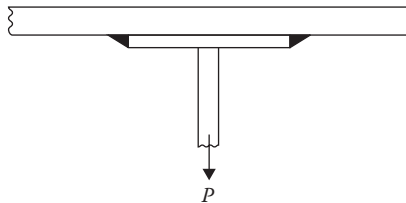


FIGURE 13.6 Welds in tension.

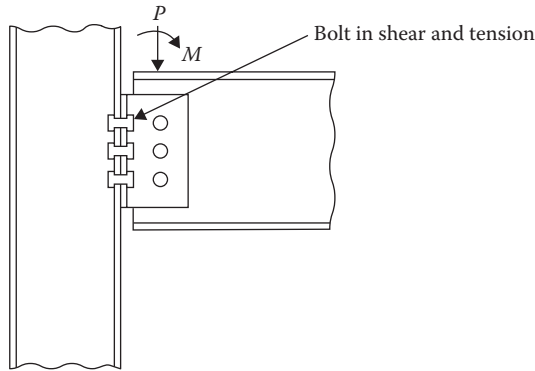


FIGURE 13.7 Bolts in shear and tension.

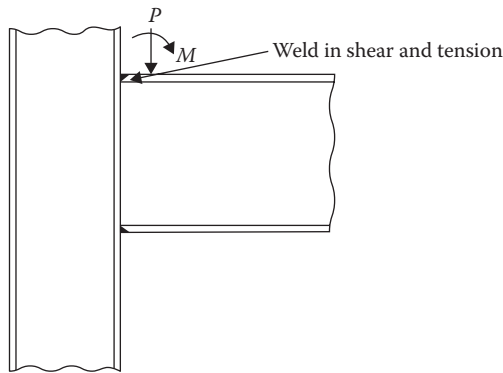


FIGURE 13.8 Welds in shear and tension.

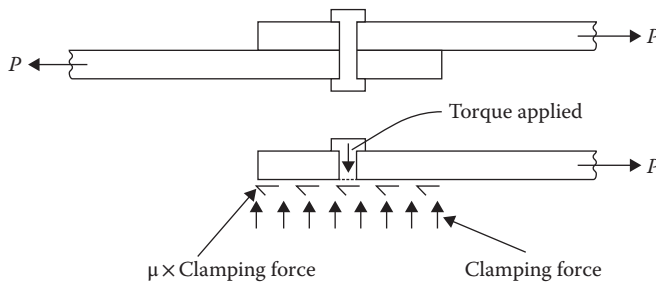


FIGURE 13.9 Frictional resistance in a slip-critical connection.

High-strength bolts have strength that is twice or more of the ordinary bolts. There are two groups of high-strength bolts: Group A is equivalent to A325-type bolts and Group B is equivalent to A490-type bolts. High-strength bolts are used in two types of connections: the bearing-type connections and the slip-critical or friction-type connections.

In the bearing-type connection, in which the common bolts can also be used, no frictional resistance in the faying (contact) surfaces is assumed and a slip between the connecting members occurs as the load is applied. This brings the bolt in contact with the connecting member and the bolt bears the load. Thus, the load transfer takes place through the bolt.

In a slip-critical connection, the bolts are torqued to a high tensile stress in the shank. This develops a clamping force on the connected parts. The shear resistance to the applied load is provided by the clamping force, as shown in Figure 13.9.

Thus, in a slip-critical connection, the bolts themselves are not stressed since the entire force is resisted by the friction developed on the contact surfaces. For this purpose, the high-strength bolts are tightened to a very high degree. The minimum pretension applied to bolts is 0.7 times the tensile strength of steel. These are given in Table 13.1.

The methods available to tighten the bolts comprise (1) the turn of the nut method, (2) the calibrated wrench method, (3) the direct tension indicator method, and (4) the twist-off type tension control method in which bolts are used whose tips are sheared off at a predetermined tension level.

The slip-critical connection is a costly process subject to inspections. It is used for structures subjected to dynamic loading such as bridges where stress reversals and fatigued loading take place.

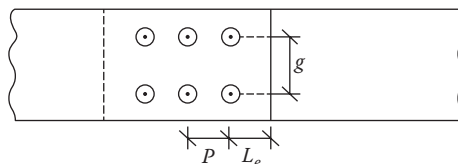
For most situations, the bearing-type connection should be used where the bolts can be tightened to the snug-tight condition, which means the tightness that could be obtained by the full effort of a person using a spud wrench or the pneumatic wrench.

### SPECIFICATIONS FOR SPACING OF BOLTS AND EDGE DISTANCE

1. *Definitions:* The following definitions are given with respect to Figure 13.10.
  - Gage, g:* This is the center-to-center distance between two successive lines of bolts, perpendicular to the axis of a member (perpendicular to the load).
  - Pitch, p:* This is the center-to-center distance between two successive bolts along the axis of a member (in line with the force).
  - Edge distance,  $L_e$ :* This is the distance from the center of the outermost bolt to the edge of a member.
2. *Minimum spacing:* The minimum center-to-center distance for standard, oversized, and slotted holes should not be less than  $2\frac{2}{3}d$ , but a distance of  $3d$  is preferred;  $d$  being the bolt diameter.
3. *Maximum spacing:* The maximum spacing of bolts of the painted members or the unpainted members not subject to corrosion should not exceed 24 times the thickness of thinner member or 12 in. whichever is less. The maximum spacing for members subject to corrosion should not exceed 14 times thickness or 7 in. whichever is less.

**TABLE 13.1**  
**Minimum Pretension on Bolts, k**

Bolt Diameter (in.)	Area (in. <sup>2</sup> )	Group A, e.g., A325 Bolts	Group B, e.g., A490 Bolts
1/2	0.0196	12	15
5/8	0.307	19	24
3/4	0.442	28	35
7/8	0.601	39	49
1	0.785	51	64
1¼	1.227	71	102
1½	1.766	103	148



**FIGURE 13.10** Definition sketch.



4. *Minimum edge distance*: The minimum edge distance in any direction are tabulated by the AISC. It is generally  $1\frac{3}{4}$  times the bolt diameter for the sheared edges and  $1\frac{1}{4}$  times the bolt diameter for the rolled or gas cut edges.
5. *Maximum edge distance*: The maximum edge distance should not exceed 12 times the thickness of the thinner member or 6 in. whichever is less.

**BEARING-TYPE CONNECTIONS**

The design basis of a connection is as follows:

$$P_u \leq \phi R_n \tag{13.1}$$

where

- $P_u$  is applied factored load on a connection
- $\phi$  is resistance factor = 0.75 for a connection
- $R_n$  is nominal strength of a connection

In terms of the nominal unit strength (stress), Equation 13.1 can be expressed as

$$P_u \leq \phi F_n A \tag{13.2}$$

For bearing-type connections,  $F_n$  refers to the nominal unit strength (stress) for the various limit states or modes of failure and  $A$  refers to the relevant area of failure.

The failure of a bolted joint in a bearing-type connection can occur by the following modes:

1. Shearing of the bolt across the plane between the members: In single shear in the lap joint and in double shear in the butt joint, as shown in Figure 13.11.  
For a single shear

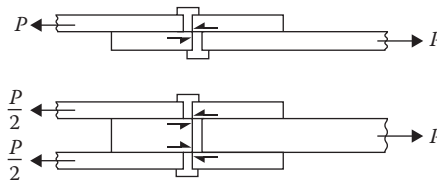
$$A = \frac{\pi}{4} d^2$$

and for a double shear

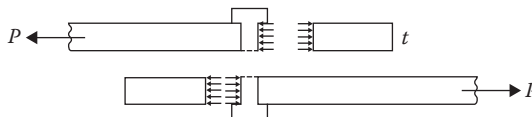
$$A = \frac{\pi}{2} d^2$$

2. Bearing failure on the contact area between the bolt and the plate, as shown in Figure 13.12.

$$A = d \cdot t$$



**FIGURE 13.11** Shear failure.



**FIGURE 13.12** Bearing failure.

- 3. Tearing out of the plate from the bolt, as shown in Figure 13.13.

$$A = \text{tearing area} = 2L_c t$$

- 4. Tensile failure of plate as shown in Figure 13.14. This condition has been discussed in Chapter 9 for tension members. It is not a part of the connection.

For the shearing type of the limiting state,  $F_n$  in Equation 13.2 is the nominal unit shear strength of bolts,  $F_{nv}$ , which is taken as 50% of the ultimate strength of bolts. The cross-sectional area,  $A_b$ , is taken as the area of the unthreaded part or the body area of bolt. If the threads are in the plane of shear or are not excluded from shear plane, a factor of 0.8 is applied to reduce the area. This factor is incorporated in the strength,  $F_{nv}$ .

Thus, for the shear limit state, the design strength is given by

$$P_u \leq 0.75F_{nv}A_b n_b \tag{13.3}$$

where

$F_{nv}$  is as given in Table 13.2

$A_b = (\pi/4)d^2$  for single shear and  $A = (\pi/2)d^2$  for double shear

$n_b$  is number of bolts in the connection

In Table 13.2, threads not excluded from shear plane are referred to as the N-type connection, like 32-N, and threads excluded from shear plane as the X-type connection, like 325-X.

The other two modes of failure, that is, the bearing and the tearing out of a member, are based not on the strength of bolts but upon the parts being connected. The areas for bearing and tearing

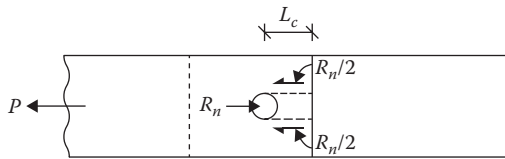


FIGURE 13.13 Tearing out of plate.



FIGURE 13.14 Tensile failure of plate.

**TABLE 13.2**  
**Nominal Unit Shear Strength,  $F_{nv}$**

Bolt Type	$F_{nv}$ (ksi)
A307	27
Group A (e.g., A325-N) threads not excluded from shear plane	54
Group A (e.g., A325-X) threads excluded from shear plane	68
Group B (e.g., A490-N) threads not excluded from shear plane	68
Group B (e.g., A490-X) threads excluded from shear plane	84

are described in the preceding discussion. The nominal unit strengths in the bearing and the (shear) tear out depend on the deformation around the holes that can be tolerated and on the types of holes. The bearing strength is very high because the tests have shown that the bolts and the connected member actually do not fail in bearing but the strength of the connected parts is impaired. The AISC expressions combine the bearing and (shear) tear state limits together as follows:

1. For standard, oversized, short-slotted holes and long-slotted holes with slots parallel to the force where deformation of hole should be  $\leq 0.25$  in. (i.e., deformation is a consideration)

$$P_u = 1.2\phi L_c t F_u n_b \leq 2.4\phi d t F_u n_b \tag{13.4}$$

where  $F_u$  is ultimate strength of the connected member.

2. For standard, oversized, short-slotted holes and long-slotted holes parallel to the force where deformations can be  $> 0.25$  in. (i.e., deformation is not a consideration)

$$P_u = 1.5\phi L_c t F_u n_b \leq 3\phi d t F_u n_b \tag{13.5}$$

3. For long-slotted holes, slots being perpendicular to the force

$$P_u = 1.0\phi L_c t F_u n_b \leq 2.0\phi d t F_u n_b \tag{13.6}$$

where

$\phi$  is 0.75

$L_c$  is illustrated in Figure 13.15.

For edge bolt #1

$$L_c = L_e - \frac{h}{2} \tag{13.7}$$

For interior bolt #2

$$L_c = s - h \tag{13.8}$$

where  $h$  = hole diameter =  $(d + 1/8)$  in.\*

In the case of double shear, if the combined thickness of two outside elements is more than the thickness of the middle element, the middle element is considered for design using twice the bolt area for shear strength and the thickness of the middle element for bearing strength. However, if the combined thickness of outer elements is less than the middle element, then the outer element is considered in design with one-half of the total load, which each outside element shares.

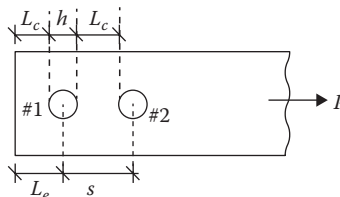


FIGURE 13.15 Definition of  $L_c$ .

\* The AISC stipulates  $d + 1/16$  but  $1/8$  has been used conservatively.

**Example 13.1**

A channel section C9 × 15 of A36 steel is connected to a 3/8-in. steel gusset plate, with 7/8-in. diameter, Group A: A325 bolts. A service dead load of 20 k and live load of 50 k is applied to the connection. Design the connection. The slip of the connection is permissible. The threads are excluded from the shear plane. Deformation of the hole is a consideration.

**SOLUTION**

A. The factored load

$$P_u = 1.2(20) + 1.6(50) = 104 \text{ k}$$

B. Shear limit state

1.  $A_b = (\pi/4)(7/8)^2 = 0.601 \text{ in.}^2$
2. For Group A: A325-X,  $F_{nv} = 68 \text{ ksi}$
3. From Equation 13.3

$$\begin{aligned} \text{No. of bolts} &= \frac{P_u}{0.75F_{nv}A_b} \\ &= \frac{104}{0.75(68)(0.601)} = 3.39 \text{ or } 4 \text{ bolts} \end{aligned}$$

C. Bearing limit state

1. Minimum edge distance

$$L_e = 1\frac{3}{4}\left(\frac{7}{8}\right) = 1.53 \text{ in.}, \text{ use } 2 \text{ in.}$$

2. Minimum spacing

$$s = 3\left(\frac{7}{8}\right) = 2.63 \text{ in.}, \text{ use } 3 \text{ in.}$$

3.  $h = d + \frac{1}{8} = 1 \text{ in.}$

4. For holes near edge

$$\begin{aligned} L_e &= L_e - \frac{h}{2} \\ &= 2 - \frac{1}{2} = 1.5 \text{ in.} \end{aligned}$$

$t = 5/16 \text{ in.}$  for the web of the channel section

For a standard size hole of deformation  $< 0.25 \text{ in.}$  (deformation is a consideration)

$$\begin{aligned} \text{Strength/bolt} &= 1.2\phi L_c t F_u \\ &= 1.2(0.75)(1.5)\left(\frac{5}{16}\right)(58) = 24.5 \text{ k} \leftarrow \text{Controls} \end{aligned}$$

$$\begin{aligned} \text{Upper limit} &= 2.4\phi d t F_u \\ &= 2.4(0.75)\left(\frac{7}{8}\right)\left(\frac{5}{16}\right)(58) = 28.55 \text{ k} \end{aligned}$$

5. For interior holes

$$L_c = s - h = 3 - 1 = 2 \text{ in.}$$

6. Strength/bolt =  $1.2(0.75)(2)\left(\frac{5}{16}\right)(58) = 32.63 \text{ k}$

$$\text{Upper limit} = 2.4(0.75)\left(\frac{7}{8}\right)\left(\frac{5}{16}\right)(58) = 28.55 \text{ k} \leftarrow \text{Controls}$$

7. Suppose there are  $n$  lines of holes with two bolts in each, then

$$P_u = 104 = n(24.5) + n(28.55)$$

$$n = 1.96$$

$$\text{Total no. of bolts} = 2(1.96) = 3.92 \text{ or } 4 \text{ bolts}$$

Select four bolts either by shear or bearing.

8. The section has to be checked for the tensile strength and the block shear by the procedure given in Chapter 9 under the "Tensile Strength of Elements" and "Block Shear Strength" sections, respectively.

## SLIP-CRITICAL CONNECTIONS

In a slip-critical connection, the bolts are not subjected to any stress. The resistance to slip is equal to the product of the tensile force between the connected parts and the static coefficient of friction. This is given by

$$P_u = \phi D_u \mu h_f T_b N_s n_b \quad (13.9)$$

where

$\phi$  is a resistance factor with different values as follows:

1. Standard holes and short-slotted holes perpendicular to the direction of load,  $\phi = 1$
2. Short-slotted holes parallel to the direction of load,  $\phi = 0.85$
3. Long-slotted holes,  $\phi = 0.70$

$D_u$  is the ratio of installed pretension to minimum pretension; use  $D_u = 1.13$ , other values permitted.

$\mu$  is the slip (friction) coefficient as given in Table 13.3.

$h_f$  is the factor for fillers, as follows:

1. No filler or where the bolts have been added to distribute loads in fillers,  $h_f = 1$
2. One filler between connected parts,  $h_f = 1$
3. Two or more fillers,  $h_f = 0.85$

$T_b$  is minimum bolt pretension given in Table 13.1

$N_s$  is number of slip (shear) planes

$n_b$  is number of bolts in the connection

**TABLE 13.3**  
**Slip (Friction) Coefficient**

Class	Surface	$\mu$
Class A	Unpainted clean mill scale or Class A coating on blast cleaned steel or hot dipped galvanized and roughened surface	0.30
Class B	Unpainted blast cleaned surface or Class B coating on blast cleaned steel	0.5

Although there is no bearing on bolts in a slip-critical connection, the AISC requires that it should also be checked as a bearing-type connection by Equation 13.3 and a relevant equation out of Equations 13.4 through 13.6.

### Example 13.2

A double-angle tensile member consisting of 2 L 3 × 2½ × ¼ is connected by a gusset plate ¾ in. thick. It is designed for a service load of 15 k and live load of 30 k. No slip is permitted. Use 5/8-in. Group A: A325 bolts and A572 steel. Holes are standard size and bolts are excluded from the shear plane. There are no fillers and the surface is blast cleaned coat A. Deformation of the hole is a consideration.

### SOLUTION

A. Factored design load

$$P_u = 1.2(15) + 1.6(30) = 66 \text{ k}$$

B. For the slip-critical limit state

1.  $D_u = 1.13$
2. Standard holes,  $\phi = 1$
3. No fillers,  $h_f = 1$
4. Class A surface,  $\mu = 0.3$
5. From Table 13.1,  $T_b = 19$  ksi for 5/8-in. bolts
6. For double shear (double angle),  $N_s = 2$   
From Equation 13.9

$$\begin{aligned} n_b &= \frac{P_u}{\phi D_u \mu h_f T_b N_s} \\ &= \frac{66}{1(1.13)(0.3)(1)(19)(2)} = 5.12 \end{aligned}$$

C. Check for the shear limit state as a bearing-type connection

1.  $A_b = 2(\pi/4)(5/8)^2 = 0.613 \text{ in.}^2$
2. For Group A: A325-X,  $F_{nv} = 66$  ksi
3. From Equation 13.3

$$\begin{aligned} \text{No. of bolts} &= \frac{P_u}{0.75 F_{nv} A_b} \\ &= \frac{66}{0.75(66)(0.613)} = 2.18 \end{aligned}$$

D. Check for the bearing limit state as a bearing-type connection

1. Minimum edge distance

$$L_e = 1\frac{3}{4} \left( \frac{5}{8} \right) = 1.09 \text{ in.}, \text{ use } 1.5 \text{ in.}$$

2. Minimum spacing

$$s = 3 \left( \frac{5}{8} \right) = 1.88 \text{ in.}, \text{ use } 2 \text{ in.}$$

3.  $h = d + \frac{1}{8} = \frac{3}{4}$  in.  
 4. For holes near edge

$$L_c = L_e - \frac{h}{2}$$

$$= 1.5 - \frac{6}{16} = 1.125$$

$t = 2(1/4) = 0.5$  in. ← thinner than the gusset plate  
 For a standard size hole of deformation  $< 0.25$  in. (deformation is a consideration)

$$\text{Strength/bolt} = 1.2\phi L_c t F_u$$

$$= 1.2(0.75)(1.125)(0.5)(65) = 32.9 \text{ k} \leftarrow \text{Controls}$$

$$\text{Upper limit} = 2.4\phi d t F_u$$

$$= 2.4(0.75)\left(\frac{5}{8}\right)(0.5)(65) = 36.56 \text{ k}$$

5. For interior holes

$$L_c = s - h = 2 - \left(\frac{3}{4}\right) = 1.25 \text{ in.}$$

6.  $\text{Strength/bolt} = 1.2(0.75)(1.25)(0.5)(65) = 36.56 \text{ k}$

$$\text{Upper limit} = 2.4(0.75)\left(\frac{5}{8}\right)(0.5)(65) = 36.56 \text{ k} \leftarrow \text{Controls}$$

7. Suppose there are  $n$  lines of holes with two bolts in each, then

$$P_u = 66 = n(32.9) + n(36.56)$$

$$n = 1$$

Total no. of bolts = 2

- E. The slip-critical limit controls the design

Number of bolts selected = 6 for symmetry

- F. Check for the tensile strength of bolt, as per Chapter 9—"Tensile Strength of Elements" section  
 G. Check for the block shear, as per Chapter 9—"Block Shear Strength" section

## TENSILE LOAD ON BOLTS

This section applies to tensile loads on bolts, in both the bearing type of connections and the slip-critical connections. The connections subjected to pure tensile loads (without shear) are limited. These connections exist in hanger-type connections for bridges, flange connections for piping systems, and wind-bracing systems in tall buildings. A hanger-type connection is shown in Figure 13.16.

A tension by the external loads acts to relieve the clamping force between the connected parts that causes a reduction in the slip resistance. This has been considered in the "Combined Shear and Tensile Forces on Bolts" section. However, as far as the tensile strength of the bolt is concerned, it is computed without giving any consideration to the initial tightening force or pretension.

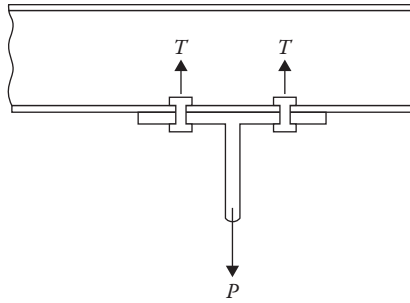


FIGURE 13.16 T-type hanger connection.

**TABLE 13.4**  
Nominal Unit Tensile Strength,  $F_{nt}$

Bolt Type	$F_{nt}$ (ksi)
A307	45
A325	90
A490	113

The tensile limit state of rupture follows the standard form of Equation 13.2:

$$T_u \leq 0.75F_{nt}A_b \cdot n_b \quad (13.10)$$

where

$T_u$  is factored design tensile load

$F_{nt}$  is nominal unit tensile strength as given in Table 13.4

### Example 13.3

Design the hanger connection shown in Figure 13.17 for the service dead and live loads of 30 k and 50 k, respectively. Use Group A: A325 bolts.

### SOLUTION

1. Factored design load

$$P_u = 1.2(30) + 1.6(50) = 116 \text{ k}$$

2. Use 7/8-in. bolt

$$A_b = \frac{\pi}{4} \left( \frac{7}{8} \right)^2 = 0.601 \text{ in.}^2$$

3. From Equation 3.10

$$n_b = \frac{P_u}{0.75F_{nt}A_b}$$

$$= \frac{116}{0.75(90)(0.601)} = 2.86, \text{ use 4 bolts, 2 on each side}$$



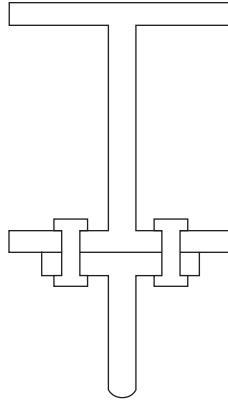


FIGURE 13.17 A tensile connection for Example 13.3.

## COMBINED SHEAR AND TENSILE FORCES ON BOLTS

### COMBINED SHEAR AND TENSION ON BEARING-TYPE CONNECTIONS

Many connections are subjected to a combination of shear and tension. A common case is a diagonal bracing attached to a column.

When both tension and shear are imposed, the interaction of these two forces in terms of the combined stress must be considered to determine the capacity of the bolt. A simplified approach to deal with this interaction is to reduce the unit tensile strength of a bolt to  $F'_nt$  (from the original  $F_{nt}$ ). Thus, the limiting state equation is

$$T_u \leq 0.75F'_nt A_b \cdot n_b \tag{13.11}$$

where the adjusted (reduced) nominal unit tensile strength is given as follows:\*

$$F'_nt = 1.3F_{nt} - \left( \frac{F_{nt}}{0.75F_{nv}} \right) f_v \leq F_{nt} \tag{13.12}$$

where  $f_v$  is actual shear stress given by the design shear force divided by the area of the number bolts in the connection.

To summarize, for combined shear and tension in a bearing-type connection, the procedure comprises the following steps:

1. Use the unmodified shear limiting state equation (Equation 13.3).
2. Use the tension limiting state equation (Equation 13.11) as a check.
3. Use the relevant bearing limiting state equation from Equations 13.4 through 13.6 as a check.

### Example 13.4

A WT12 × 27.5 bracket of A36 steel is connected to a W14 × 61 column, as shown in Figure 13.18, to transmit the service dead and live loads of 15 and 45 k. Design the bearing-type connection between the column and the bracket using 7/8-in. Group A: 325-X bolts. Deformation is a consideration.

\* When the actual shear stress  $f_v \leq 0.3\phi F_{nv}$  or the actual tensile stress  $f_t \leq 0.3\phi F_{nt}$ , the adjustment of  $F_{nt}$  is not required.

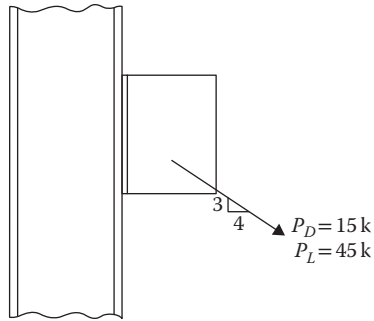


FIGURE 13.18 Column-bracket connection for Example 13.4.

### SOLUTION

#### A. Design data

1. Thickness of bracket = 0.505 in.
2. Thickness of column = 0.645 in.
3.  $P_u = 1.2(15) + 1.6(45) = 90$  k
4. Design shear,  $V_u = P_u(3/5) = 54$  k
5. Design tension,  $T_u = P_u(4/5) = 72$  k

#### B. For the shear limiting state

1.  $A_b = (\pi/4)(7/8)^2 = 0.601$  in.<sup>2</sup>
2. For Group A, A325-X,  $F_{nv} = 68$  ksi
3. From Equation 13.3

$$n_b = \frac{V_u}{0.75F_{nv}A_b}$$

$$= \frac{54}{0.75(68)(0.601)} = 1.762 \text{ bolts}$$

Use four bolts, two on each side (minimum two bolts on each side)

#### C. For the tensile limiting state

1.  $F_{nt} = 90$  ksi
2. Actual shear stress

$$f_v = \frac{V_u}{A_b n_b} = \frac{54}{(0.601)(4)} = 22.46 \text{ ksi}$$

3. Adjusted unit tensile strength from Equation 13.12

$$F'_{nt} = 1.3F_{nt} - \left( \frac{F_{nt}}{0.75F_{nv}} \right) f_v \leq F_{nt}$$

$$= 1.3(90) - \frac{90}{0.75(68)}(22.46) = 77.36 \text{ ksi} \quad \mathbf{OK}$$

4. From Equation 13.11

$$n_b = \frac{T_u}{0.75F'_{nt}A_b}$$

$$= \frac{72}{0.75(77.36)(0.601)} = 2.06 < 4 \text{ bolts} \quad \mathbf{OK}$$

D. Check for the bearing limit state

1. Minimum edge distance

$$L_e = 1\frac{3}{4}\left(\frac{7}{8}\right) = 1.53 \text{ in.}, \text{ use } 2 \text{ in.}$$

2. Minimum spacing

$$s = 3\left(\frac{7}{8}\right) = 2.63 \text{ in.}, \text{ use } 3 \text{ in.}$$

3.  $h = d + \frac{1}{8} = 1 \text{ in.}$

4. For holes near edge

$$\begin{aligned} L_e &= L_e - \left(\frac{h}{2}\right) \\ &= 2 - \left(\frac{1}{2}\right) = 1.5 \text{ in.} \end{aligned}$$

$t = 0.505 \text{ in.}$  ← thickness of WT flange

For a standard size hole of deformation  $< 0.25 \text{ in.}$  (deformation is a consideration)

$$\begin{aligned} \text{Strength} &= 1.2\phi L_c t F_u n_b \\ &= 1.2(0.75)(1.5)(0.505)(58)(4) = 158 \text{ k} \leftarrow \text{controls } > 54 \text{ k} \quad \mathbf{OK} \end{aligned}$$

$$\begin{aligned} \text{Upper limit} &= 2.4\phi d t F_u n_b \\ &= 2.4(0.75)\left(\frac{7}{8}\right)(0.505)(58)(4) = 184.5 \text{ k} \end{aligned}$$

### COMBINED SHEAR AND TENSION ON SLIP-CRITICAL CONNECTIONS

As discussed in the “Tensile Load on Bolts” section, the externally applied tension tends to reduce the clamping force and the slip-resisting capacity. A reduction factor  $k_s$  is applied to the previously described slip-critical strength. Thus, for the combined shear and tension, the slip-critical limit state is

$$V_u = \phi D_u \mu h_f T_b N_s n_b k_s \quad (13.13)$$

where

$$k_s = \frac{1 - T_u}{D_u T_b n_b} \quad (13.14)$$

$V_u$  is factored shear load on the connection

$T_u$  is factored tension load on the connection

$T_b$  is minimum bolt pretension given in Table 13.1

$N_s$  is number of slip (shear) planes

$n_b$  is number of bolts in the connection

$h_f$  is a factor for fillers defined in Equation 13.9

$\mu$  is slip (friction) coefficient as given in Table 13.3

Combining Equations 13.13 and 13.14, the relation for the number of bolts is

$$n_b = \frac{1}{D_u T_b} \left( \frac{V_u}{\phi \mu h_f} + T_u \right) \quad (13.15)$$

To summarize, for the combined shear and tension in a slip-critical connection, the procedure is as follows:

1. Use the shear limiting state equation (Equation 13.3).\*
2. Use the (original) tensile limit state equation (Equation 13.10).
3. Use the relevant bearing limiting state equation from Equations 13.4 through 13.6 as a check.
4. Use the (modified) slip-critical limit state equation (Equation 13.13).

### Example 13.5

Design Example 13.4 as a slip-critical connection. The holes are standard size. There is no filler. The surface is unpainted clean mill scale.

### SOLUTION

A. Design loads from Example 13.4

1.  $V_u = 54$  k
2.  $T_u = 72$  k

B. For the shear limiting state

$$n_b = 1.762 \text{ from Example 13.4 (use four bolts, min. two on each side)}$$

C. For the tensile limiting state

$$\begin{aligned} n_b &= \frac{T_u}{0.75 F_{nt} A_b} \\ &= \frac{72}{0.75(90)(0.601)} = 1.77 < 4 \text{ bolts} \quad \mathbf{OK} \end{aligned}$$

D. For the bearing limit state

$$\text{Strength} = 158 \text{ k (from Example 13.4)} > 54 \text{ K} \quad \mathbf{OK}$$

E. For the slip-critical limit state

1. Standard holes,  $\phi = 1$
2. No filler,  $h_f = 1$
3. Class A surface,  $\mu = 0.3$
4. From Table 13.1,  $T_b = 39$  ksi
5. For single shear,  $N_s = 1$
6. From Equation 13.15

$$\begin{aligned} n_b &= \frac{1}{D_u T_b} \left( \frac{V_u}{\phi \mu h_f} + T_u \right) \\ &= \frac{1}{1.13(39)} \left[ \frac{54}{(1)(0.3)(1)} + 72 \right] \\ &= 5.72 \text{ bolts (select 6 bolts, 3 on each side of web)} \end{aligned}$$

\* The slip-critical connections also are required to be checked for bearing capacity and shear strength.

## WELDED CONNECTIONS

Welding is a process in which the heat of an electric arc melts the welding electrode and the adjacent material of the part being connected simultaneously. The electrode is deposited as a filler metal into the steel, which is referred to as the *base metal*. There are two types of welding processes. The *shielded metal arc welding* (SMAW), usually done manually, is the process used for field welding. The *submerged arc welding* (SAW) is an automatic or semiautomatic process used in shop welding. The strength of a weld depends on the weld metal used, which is the strength of the electrode used. An electrode is specified by the letter E followed by the tensile strength in ksi and the last two digits specifying the type of coating. Since strength is a main concern, the last two digits are specified by XX, a typical designation being E 70 XX. The electrode should be selected to have a larger tensile strength than the base metal (steel). For steel of 58 ksi strength, the electrode E 70 XX is used, and for 65 ksi steel, the electrode E 80 XX is used. Electrodes of high strength E 120 XX are available.

The two common types of welds are fillet welds and groove or the butt welds, as shown in Figure 13.19. Groove welds are stronger and more expensive than fillet welds. Most of the welded connections are made by fillet welds because of a larger allowed tolerance.

The codes and standards for welds are prepared by the American Welding Society. These have been adopted in the *AISC Manual 2010*.

## GROOVE WELDS

### EFFECTIVE AREA OF GROOVE WELD

The effective area of a complete-joint-penetration (CJP) groove weld is the length times the thickness of the thinner part joined.

The effective area of a partial-joint-penetration (PJP) groove weld is the length times the depth (effective throat) of the groove.\* The minimum effective throat for PJP weld has been listed in the *AISC Manual 2010*. It is 1/8 in. for 1/4 in. material thickness to 5/8 in. for over 6 in. thick material joined.

## FILLET WELDS

### EFFECTIVE AREA OF FILLET WELD

The cross section of a fillet weld is assumed to be a 45° right angle triangle, as shown in Figure 13.20. Any additional buildup of weld is neglected. The size of the fillet weld is denoted by the sides of the triangle,  $w$ , and the throat dimension, given by the hypotenuse,  $t$ , which is equal to  $0.707w$ . When the SAW process is used, the greater heat input produces a deeper penetration.

The effective throat size is taken as follows:

$$T_e = t = 0.707w \quad (13.16)$$

### MINIMUM SIZE OF FILLET WELD

The minimum size should not be less than the dimension shown in Table 13.5.

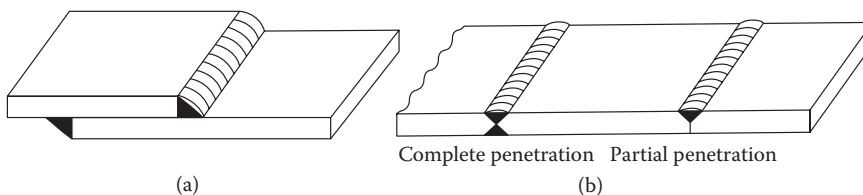


FIGURE 13.19 Types of welds: (a) fillet and (b) groove of butt welds.

\* For gas metal arc and flux cored arc, the groove depth is subtracted by 1/8 in.

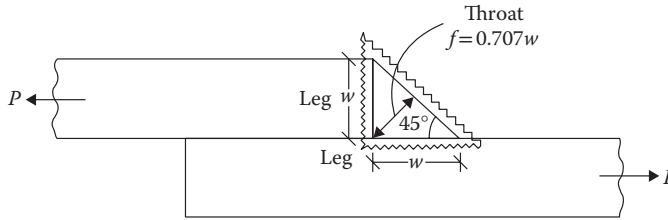


FIGURE 13.20 Fillet weld dimensions.

**TABLE 13.5**  
**Minimum Size of Weld (in.)**

Base Material Thickness of Thinner Part (in.)	w (in.)
≤1/4	1/8
>1/4 to ≤1/2	3/16
>3/4 to ≤3/4	1/4
>3/4	5/16

**MAXIMUM SIZE OF FILLET WELD**

1. Along the edges of material less than 1/4 in. thick, the weld size should not be greater than the thickness of the material.
2. Along the edges of material 1/4 in. or more, the weld size should not be greater than the thickness of the material less 1/4 in.

**LENGTH OF FILLET WELD**

1. The effective length of end-loaded fillet weld,  $L_E$ , is equal to the actual length for the length up to 100 times the weld size. When the length exceeds 100 times the weld size, the actual length is multiplied by a reduction factor  $\beta = 1.2 - 0.002 (l/w)$ , where  $l$  is actual length and  $w$  is weld size. When the length exceeds 300 times the weld size, the effective length is  $180 w$ .
2. The minimum length should not be less than four times the weld size.
3. If only the longitudinal welds are used, the length of each side should not be less than the perpendicular distance between the welds.

**STRENGTH OF WELD**

**COMPLETE JOINT PENETRATION GROOVE WELDS**

Since the weld metal is always stronger than the base metal (steel), the strength of a CJP groove weld is taken as the strength of the base metal. The design of the connection is not done in the normal sense.

For the combined shear and tension acting on a CJP groove weld, there is no explicit approach. The generalized approach is to reduce the tensile strength by a factor of  $(f_v/F)^2$  subject to a maximum reduction of 36% of the tensile strength.

**PARTIAL JOINT PENETRATION WELDS AND FILLET WELDS**

A weld is weakest in shear and is always assumed to fail in the shear mode. Although a length of weld can be loaded in shear, compression, or tension, the failure of a weld is assumed to occur in the shear rupture through the throat of the weld. Thus,

$$P_u = \phi F_w A_w \tag{13.17}$$

where

$\phi$  is resistance factor = 0.75

$F_w$  is strength of weld =  $0.6F_{EXX}$

$F_{EXX}$  is strength of electrode

$A_w$  is effective area of weld =  $T_e L$

However, there is a requirement that the weld shear strength cannot be larger than the base metal shear strength. For the base metal, the shear yield and shear rupture strengths are taken to be 0.6 times the tensile yield of steel and 0.6 times the ultimate strength of steel, respectively. The yield strength is applied to the gross area and the rupture strength to the net area of shear surface, but in the case of a weld, both areas are the same. The resistance factor is 1 for shear yield and 0.75 for shear rupture.

Thus, the PJP groove and the fillet welds should be designed to meet the strengths of the weld and the base metal, whichever is smaller, as follows:

1. Weld shear rupture limit state

By the substitution of the terms in Equation 13.17

$$P_u = 0.45F_{EXX}T_eL_E \quad (13.18)$$

where

$F_{EXX}$  is strength of electrode, ksi

$L_E$  is effective length of weld

$T_e$  is effective throat dimension from Equation 13.16

2. Base metal shear limit state

a. Shear yield strength

$$P_u = 0.60F_y t L_E \quad (13.19)$$

where  $t$  is thickness of thinner connected member

b. Shear rupture strength

$$P_u = 0.45F_u T_e L_E \quad (13.20)$$

In addition, the block shear strength should also be considered by Equation 9.7.

### Example 13.6

A tensile member consisting of one  $L$   $3\frac{1}{2} \times 3\frac{1}{2} \times \frac{1}{2}$  section carries a service dead load of 30 k and live load of 50 k, as shown in Figure 13.21. A single  $\frac{3}{4}$ -in. plate is directly welded to the column flange using the CJP groove. Fillet welds attach the angles to the plate. Design the welded connection. The longitudinal length of the weld cannot exceed 5 in. Use the return (transverse) weld, if necessary. Use E70 electrodes. The steel is A36.

### SOLUTION

A. Angle plate (bracket) connection

1. Factored load

$$P_u = 1.2(30) + 1.6(50) = 116 \text{ k}$$

2. Maximum weld size. For thinner member, thickness of angle,  $t = \frac{1}{2}$  in.

$$w = t - \left(\frac{1}{16}\right) = \frac{7}{16} \text{ in.}$$

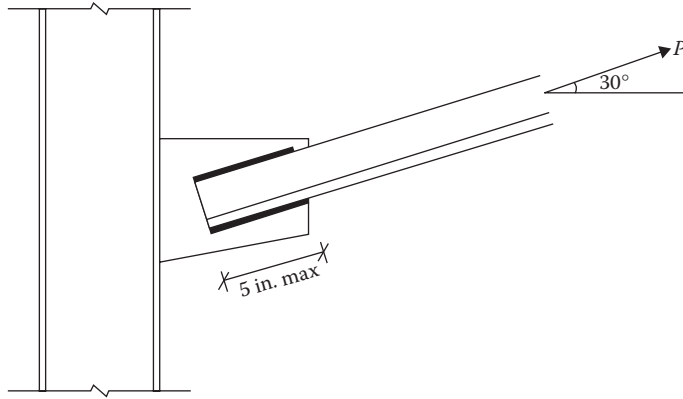


FIGURE 13.21 Column-bracket welded connection for Example 13.6.

3. Throat dimension, SMAW process

$$T_e = 0.707 \left( \frac{7}{16} \right) = 0.309 \text{ in.}$$

4. For weld shear limit state, from Equation 13.18

$$\begin{aligned} L_E &= \frac{P_u}{0.45F_{EXX}T_e} \\ &= \frac{116}{0.45(70)(0.309)} = 11.92 \text{ in.} \sim 12 \text{ in.} \leftarrow \text{controls} \end{aligned}$$

5. For steel shear yield limit state, from Equation 13.19

$$\begin{aligned} L_E &= \frac{P_u}{0.6F_y t} \\ &= \frac{116}{0.6(36) \left( \frac{1}{2} \right)} = 10.74 \text{ in.} \end{aligned}$$

6. For steel rupture limit state, from Equation 13.20

$$\begin{aligned} L_E &= \frac{P_u}{0.45F_u t} \\ &= \frac{116}{0.45(58) \left( \frac{1}{2} \right)} = 8.9 \text{ in.} \end{aligned}$$

7. Provide a 5-in.-long weld on each side\* (maximum in this problem) with 1 in. return on each side.
8. The longitudinal length of welds (5 in.) should be at least equal to the transverse distance between the longitudinal weld (3 1/2); **OK**
9. Length of 12 in. greater than 4w of 1.75 in. **OK**

\* Theoretically, the lengths on two sides are unequally distributed so that the centroid of the weld passes through the center of gravity of the angle member.



## B. Column-bracket connection

1. The connection is subjected to tension and shear as follows:

$$T_u = P_u \cos 30^\circ = 116 \cos 30^\circ = 100.5 \text{ k}$$

$$V_u = P_u \sin 30^\circ = 116 \sin 30^\circ = 58 \text{ k}$$

2. For the CJP groove, the design strengths are the same as for the base metal.
3. This is the case of the combined shear and tension in groove weld. Using a maximum reduction of 36%,\* tensile strength =  $0.76F_t$ .
4. For the base material tensile limit state

$$T_u = \phi(0.76F_t)tL, \text{ where } t \text{ is gusset plate thickness}$$

$$100.5 = 0.9(0.76)(36)\left(\frac{3}{4}\right)L$$

or

$$L = 5.44 \text{ in.} \leftarrow \text{Controls}$$

Use 6 in. weld length

5. For the base metal shear yield limit state

$$V_u = 0.6F_y tL$$

$$58 = 0.6(36)\left(\frac{3}{4}\right)L$$

or

$$L = 3.6 \text{ in.}$$

6. For the base metal shear rupture limit state

$$V_u = 0.45F_u tL$$

$$58 = 0.45(58)\left(\frac{3}{4}\right)L$$

or

$$L = 3.0 \text{ in.}$$

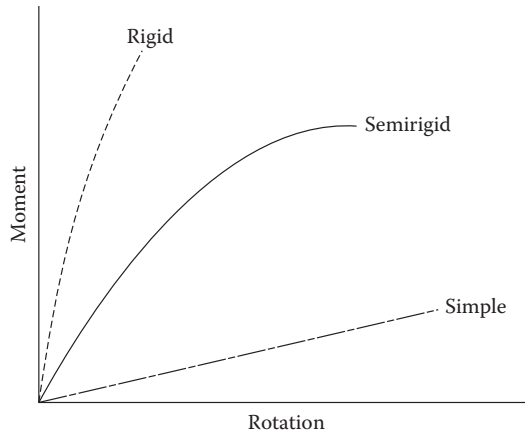
## FRAME CONNECTIONS

There are three types of beam-to-column frame connections:

1. FR (fully restrained) or rigid frame or moment frame connection  
It transfers the full joint moment and shear force.  
It retains the original angle between the members or rotation is not permitted.
2. Simple or pinned frame or shear frame connection  
It transfers shears force only.  
It permits rotation between the members.
3. PR (partially restrained) frame connection  
It transfers some moment and the entire shear force.  
It permits a specified amount of rotation.

---

\* See the "Complete Joint Penetration Groove Welds" section.



**FIGURE 13.22** Moment-rotation characteristics.

The relationship between the applied moment and the rotation (variation of angle) of members for rigid, semirigid, and simple framing is shown in Figure 13.22.

A fully rigid joint will have a small change in angle with the application of moment. A simple joint will be able to support some moment (although theoretically the moment capacity should be zero). A semirigid joint is where the actual moment and rotation are accounted for.

## SHEAR OR SIMPLE CONNECTION FOR FRAMES

There are a variety of beam-to-column or beam-to-girder connections that are purposely made flexible for rotation at the ends of the beam. These are designed for the end reaction (shear force). These are used for structures where the lateral forces due to wind or earthquake are resisted by the other systems like truss framing or shear walls. Following are the main categories of simple connections.

### SINGLE-PLATE SHEAR CONNECTION OR SHEAR TAB

This is a simple and economical approach that is becoming very popular. The holes are prepunched in a plate and in the web of the beam to be supported. The plate is welded (usually shop welded) to the supporting column or beam. The prepunched beam is bolted to the plate at the site. This is shown in Figure 13.23.

### FRAMED-BEAM CONNECTION

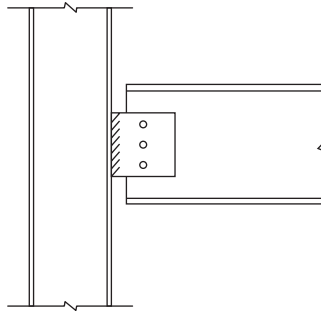
The web of the beam to be supported is connected to the supporting column through a pair of angles, as shown in Figure 13.24.

### SEATED-BEAM CONNECTION

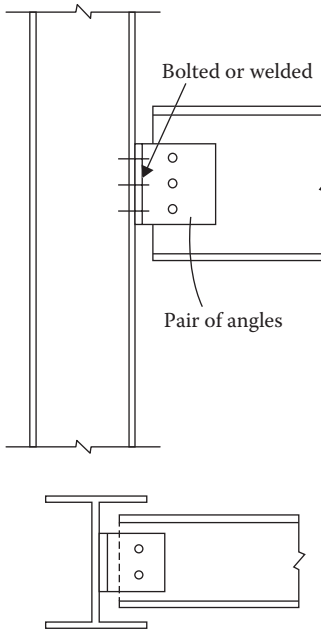
The beam to be supported sits on an angle attached to the supporting column flange, as shown in Figure 13.25.

### END-PLATE CONNECTION

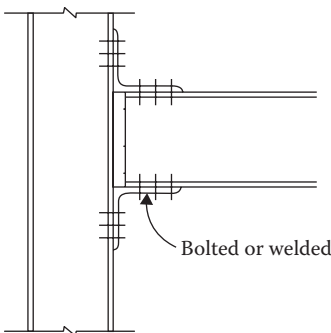
A plate is welded against the end of the beam to be supported. This plate is then bolted to the supporting column or beam at the site. This is shown in Figure 13.26. These connections are becoming popular but not as much as the single-plate connection.



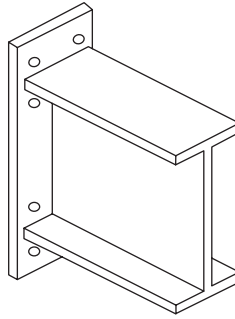
**FIGURE 13.23** Single-plate or shear tab connection.



**FIGURE 13.24** Framed-beam connection.



**FIGURE 13.25** Seated-beam connection.



**FIGURE 13.26** End-plate connection.

The design of the simple connections proceeds along the lines of the bearing-type connections described in the “Bearing-Type Connections” section. The limiting states considered are as follows: (1) shear on bolts; (2) bearing yield strength; (3) shear rupture strength between the bolt and the connected part, as discussed in the “Bearing-Type Connections” section; and (4) block shear strength of the connected part.

The *AISC Manual 2010* includes a series of tables to design the different types of bolted and welded connections. The design of only a single-plate shear connection for frames is presented here.

### SINGLE-PLATE SHEAR CONNECTION FOR FRAMES

The following are the conventional configurations for a single-plate shear connection:

1. A single row of bolts comprising 2–12 bolts.
2. The distance between the bolt line and weld line should not exceed 3.5 in.
3. Provision of the standard or short-slotted holes.
4. The horizontal distance to edge  $L_e \geq 2d_b$  (bolt diameter).
5. The plate and beam must satisfy  $t \leq (d_b/2) + (1/16)$ .
6. For welded connections, the weld shear rupture and the base metal shear limits should be satisfied.
7. For bolted connections, the bolt shear, the plate shear, and the bearing limit states should be satisfied.
8. The block shear of the plate should be satisfactory.

#### Example 13.7

Design a single-plate shear connection for a W14 × 82 beam joining a W12 × 96 column by a 3/8-in. plate, as shown in Figure 13.27. The factored reaction at the support of the beam is 50 k. Use 3/4-in.-diameter Group A: A325-X bolts, A36 steel, and E70 electrodes.

#### SOLUTION

A. Design load

$$P_u = R_u = 50 \text{ k}$$

B. For W14 × 82

$$d = 14.3 \text{ in.}, \quad t_f = 0.855 \text{ in.}, \quad t_w = 0.51 \text{ in.}, \quad b_f = 14.7 \text{ in.}$$

$$F_y = 36 \text{ ksi}, \quad F_u = 58 \text{ ksi}$$

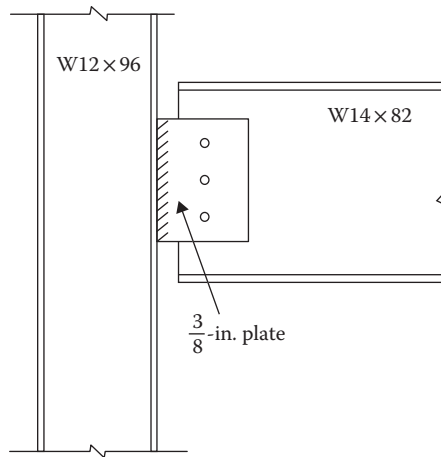


FIGURE 13.27 Single-plate connection for Example 13.7.

C. For W12 × 96

$$d = 12.7 \text{ in.}, \quad t_f = 0.9 \text{ in.}, \quad t_w = 0.55 \text{ in.}, \quad b_f = 12.2 \text{ in.}$$

$$F_y = 36 \text{ ksi}, \quad F_u = 58 \text{ ksi}$$

D. Column plate-welded connection

1. For 3/8-in. plate

$$\text{Weld max size} = t - \left(\frac{1}{16}\right) = \left(\frac{3}{8}\right) - \left(\frac{1}{16}\right) = \left(\frac{5}{16}\right) \text{ in.}$$

2.  $T_e = 0.707 (5/16) = 0.22 \text{ in.}$

3. The weld shear limit state, from Equation 13.18

$$L_E = \frac{P_u}{0.45F_{EXX}T_e}$$

$$= \frac{50}{0.45(70)(0.22)} = 7.21 \text{ in.} \sim 8 \text{ in.} \leftarrow \text{controls}$$

4. The steel shear yield limit state, from Equation 13.19

$$L = \frac{P_u}{0.6F_y t}$$

$$= \frac{50}{0.6(36)\left(\frac{3}{8}\right)} = 6.17 < 8 \text{ in.}$$

5. The steel rupture limit state, from Equation 13.20

$$L = \frac{P_u}{0.45F_u t}$$

$$= \frac{50}{0.45(58)\left(\frac{3}{8}\right)} = 5.1 \text{ in.} < 8 \text{ in.}$$

6. Up to 100 times of the weld size (in this case  $100 (5/16) = 31.25$  in.), effective length is equal to actual length, hence  $L = L_E = 8$  in.
7.  $L$  of 8 in.  $> 4w$  of 1.25 in. **OK**
- E. Beam plate-bolted connection
- E.1 The single shear limit state
1.  $A_b = (\pi/4)(3/4)^2 = 0.441$  in.<sup>2</sup>
  2. For A325-X,  $F_{nv} = 68$  ksi
  3. From Equation 13.3

$$\begin{aligned} \text{No. of bolts} &= \frac{P_u}{0.75F_{nv}A_b} \\ &= \frac{50}{0.75(68)(0.441)} = 2.22 \text{ or 3 bolts} \end{aligned}$$

E.2 The bearing limit state

1. Minimum edge distance

$$L_e = 1\frac{3}{4}d_b = 1\frac{3}{4}\left(\frac{3}{4}\right) = 1.31 \text{ in., use 1.5 in.}$$

2. Minimum spacing

$$s = 3d_b = 3\left(\frac{3}{4}\right) = 2.25 \text{ in., use 2.5 in.}$$

3.  $h = d + \frac{1}{8} = \frac{7}{8}$  in.

4. For holes near edge

$$\begin{aligned} L_c &= L_e - \left(\frac{h}{2}\right) \\ &= 1.5 - \left(\frac{7}{16}\right) = 1.063 \text{ in.} \end{aligned}$$

$t = 3/8$  in. thinner member

For a standard size hole of deformation  $< 0.25$  in.

$$\begin{aligned} \text{Strength/bolt} &= 1.2\phi L_c t F_u \\ &= 1.2(0.75)(1.063)\left(\frac{3}{8}\right)(58) = 20.81 \text{ k} \leftarrow \text{Controls} \end{aligned}$$

Upper limit  $= 2.4\phi d t F_u$

$$= 2.4(0.75)\left(\frac{3}{4}\right)\left(\frac{3}{8}\right)(58) = 29.36 \text{ k}$$

5. For other holes

$$L_c = s - h = 2.5 - \left(\frac{7}{8}\right) = 1.625 \text{ in.}$$

6.  $\text{Strength/bolt} = 1.2(0.75)(1.625)\left(\frac{3}{8}\right)(58) = 31.81 \text{ k}$

$$\text{Upper limit} = 2.4(0.75)\left(\frac{3}{4}\right)\left(\frac{3}{8}\right)(58) = 29.36 \text{ k} \leftarrow \text{Controls}$$

7. Total strength for three bolts—two near edges

$$P_u = 2(20.81) + 29.36 = 71 \text{ k} > 50 \text{ k} \quad \mathbf{OK}$$

8. The section has to be checked for block shear by the procedure given in Chapter 9.

### MOMENT-RESISTING CONNECTION FOR FRAMES

Fully restrained (rigid) and partially restrained (semirigid) are two types of moment-resisting connections. It is customary to design a semirigid connection for some specific moment capacity, which is less than the full moment capacity.

Figure 13.28 shows a moment-resisting connection that has to resist a moment,  $M$ , and a shear force (reaction),  $V$ .

The two components of the connection are designed separately. The moment is transmitted to the column flange as a couple by the two tees attached at the top and bottom flanges of the beam. This results in tension,  $T$ , on the top flange and compression,  $C$ , on the bottom flange.

From the couple expression, the two forces are given by

$$C = T = \frac{M}{d} \tag{13.21}$$

where  $d$  is taken as the depth of the beam.

The moment is taken care of by designing the tee connection for the tension  $T$ . It should be noted that the magnitude of the force  $T$  can be decreased by increasing the distance between the tees (by a deeper beam).

The shear load is transmitted to the column by the beam–web connection. This is designed as a simple connection of the type discussed in the “Shear or Simple Connection for Frames” section through single plate, two angles (framed), or seat angle.

The connecting tee element is subjected to prying action as shown in Figure 13.29. This prying action could be eliminated by connecting the beam section directly to the column through a CJP groove weld, as shown in Figure 13.30.

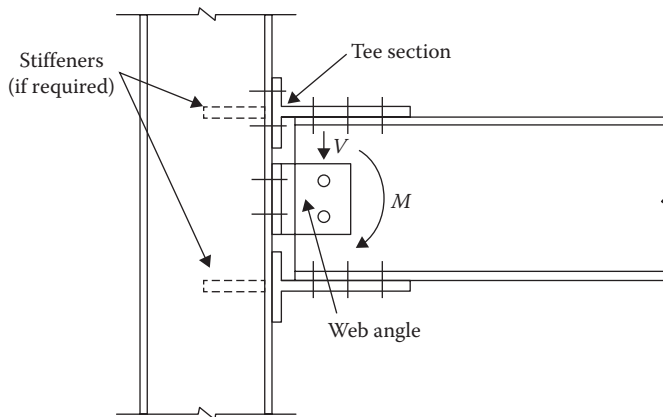


FIGURE 13.28 Moment-resisting connection.

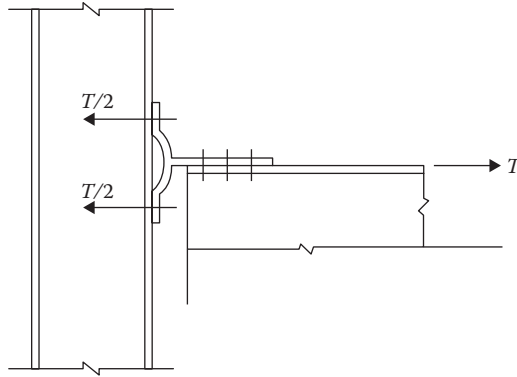


FIGURE 13.29 Prying action in connection.

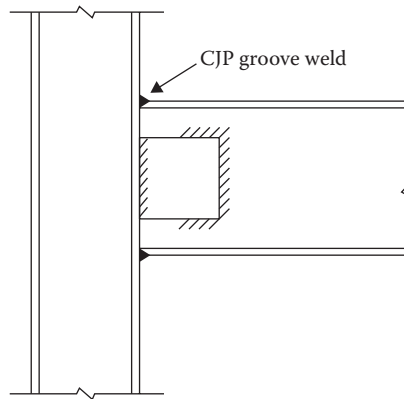


FIGURE 13.30 Welded moment-resisting connection.

The welded length should not exceed beam flange width,  $b_f$ , of both the beam and the column, otherwise a thicker plate has to be welded at the top and bottom of the beam.

**Example 13.8**

Design the connection of Example 13.7 as a moment-resisting connection subjected to a factored moment of 200 ft.-k and a factored end shear force (reaction) of 50 k. The beam flanges are groove welded to the column.

**SOLUTION**

- A. Design for the shear force has been done in Example 13.7.
- B. Flanges welded to the column

$$\begin{aligned}
 1. \quad C = T &= \frac{M}{d} \\
 &= \frac{200(12)}{14.3} = 167.83 \text{ k}
 \end{aligned}$$

- 2. The base material limit state

$$T_u = \phi F_y t L, \text{ where } t = t_f$$



or

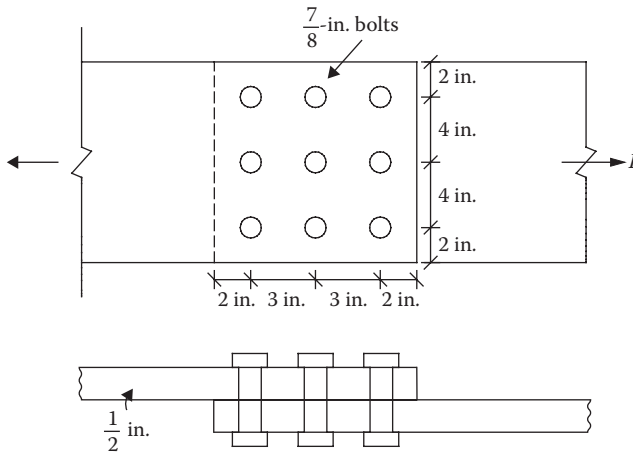
$$L = \frac{T_u}{\phi F_y t}$$

$$= \frac{167.83}{(0.9)(36)(0.855)} = 6.06 \text{ in.} < b_f$$

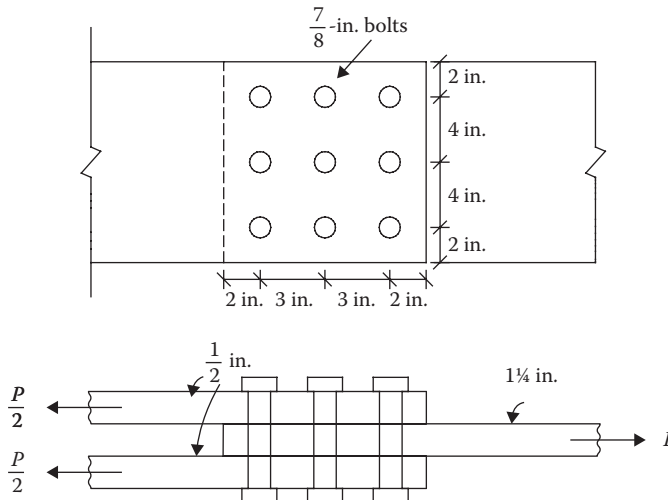
Provide a 6-in.-long CJP weld.

**PROBLEMS**

- 13.1 Determine the strength of the bearing-type connection shown in Figure P13.1. Use A36 steel, Group A: A325, 7/8-in. bolts. The threads are not excluded from shear plane. Deformation of the hole is a consideration.
- 13.2 Determine the strength of the bearing-type connection shown in Figure P13.2. Use A36 steel, Group A: A325, 7/8-in. bolts. The threads are excluded from shear plane. Deformation of holes is not a consideration.



**FIGURE P13.1** Connection for Problem 13.1.



**FIGURE P13.2** Connection for Problem 13.2.

- 13.3 Design the bearing-type connection for the bolt joint shown in Figure P13.3. The steel is A572 and the bolts are Group A: A325, 3/4-in. diameter. The threads are excluded from shear plane. Deformation of holes is a consideration.
- 13.4 A chord of a truss shown in Figure P13.4 consists of 2 C9 × 20 of A36 steel connected by a 1-in. gusset plate. Check the bearing-type connection by Group B: A490 bolts assuming threads are excluded from shear plane. Deformation of holes is not a consideration.
- 13.5 Design the bearing-type connection shown in Figure P13.5 (threads excluded from shear plane) made with 7/8-in. Group B: A490 bolts. Use A572 steel. Deformation of holes is a consideration.
- 13.6 Solve Problem 13.1 for the slip-critical connection of unpainted clean mill scale surface. The holes are standard size and there are no fillers.
- 13.7 Solve Problem 13.2 for the slip-critical connection of unpainted blast cleaned surface. The holes are standard size. Two fillers are used between connected members.
- 13.8 Design a slip-critical connection for the plates shown in Figure P13.6 to resist service dead load of 30 k and live load of 50 k. Use 1-in. Group A: A325 bolts and A572 steel. Assume painted class A surface. The holes are standard size. There are no fillers. The threads are excluded from shear plane and hole deformation is a consideration.

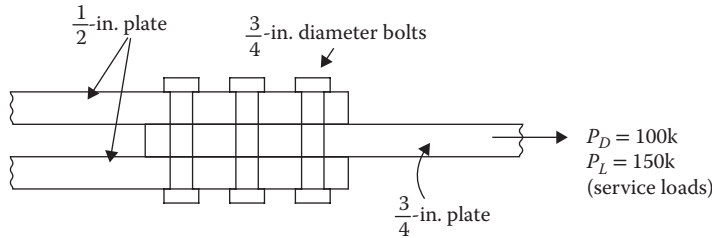


FIGURE P13.3 Connection for Problem 13.3.

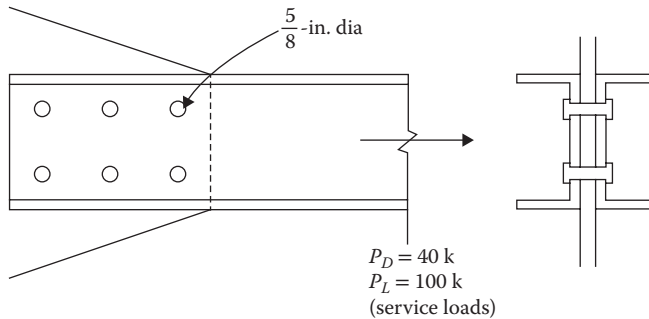


FIGURE P13.4 Truss chord connection for Problem 13.4.

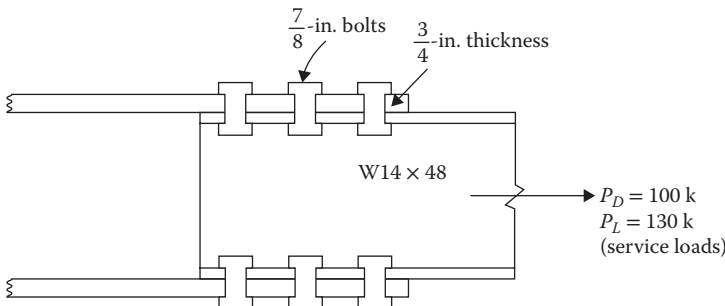


FIGURE P13.5 Connection for Problem 13.5.

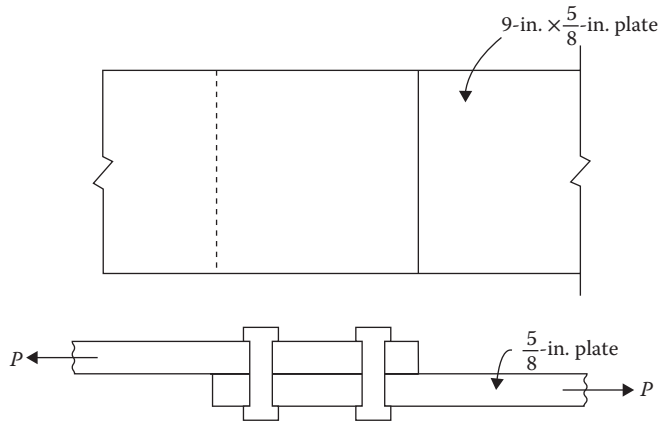


FIGURE P13.6 Connection for Problem 13.8.

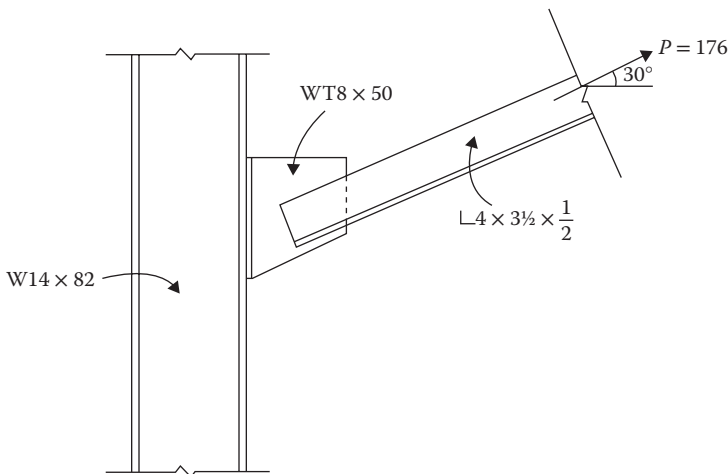


FIGURE P13.7 Connection for Problem 13.10.

- 13.9** A single angle  $3\frac{1}{2} \times 3 \times \frac{1}{4}$  tensile member is connected by a  $\frac{3}{8}$ -in.-thick gusset plate. Design a no-slip (slip-critical) connection for the service dead and live loads of 8 and 24 k, respectively. Use  $\frac{7}{8}$ -in. Group A: A325 bolts and A36 steel. Assume an unpainted blast cleaned surface. The holes are standard size. There is one filler. The threads are not excluded from shear plane and the hole deformation is not a consideration.
- 13.10** A tensile member shown in Figure P13.7 consisting of two  $L 4 \times 3\frac{1}{2} \times \frac{1}{2}$  carries a wind load of 176 k acting at  $30^\circ$ . A bracket consisting of a tee section connects this tensile member to a column flange. The connection is slip-critical. Design the bolts for the tensile member only. Use  $\frac{7}{8}$ -in. Group B: A490-X bolts and A572 steel. Assume an unpainted blast cleaned surface. The holes are short-slotted parallel to the direction of loading. There are no fillers and hole deformation is not a consideration.
- 13.11** Determine the strength of the bolts in the hanger connection shown in Figure P13.8 (neglect the prying action).
- 13.12** Are the bolts in the hanger connection adequate in Figure P13.9?
- 13.13** A  $WT12 \times 31$  is attached to a  $\frac{3}{4}$ -in. plate as a hanger connection, to support service dead and live loads of 25 and 55 k, respectively. Design the connection for  $\frac{7}{8}$ -in. Group A: A325 bolts and A572 steel (neglect the prying action).

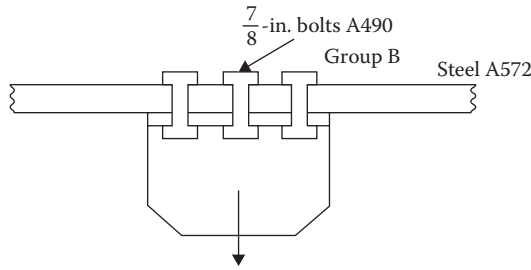


FIGURE P13.8 Hanger-type connection for Problem 13.11.

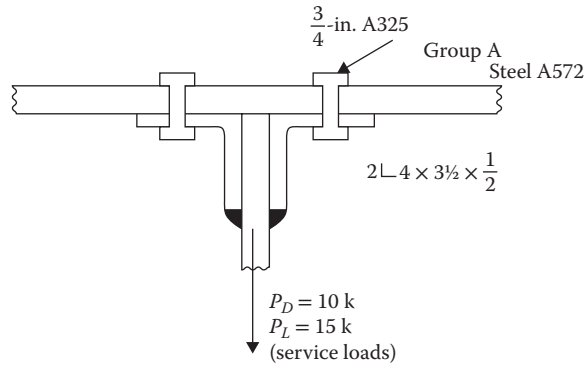


FIGURE P13.9 Hanger-type connection for Problem 13.12.

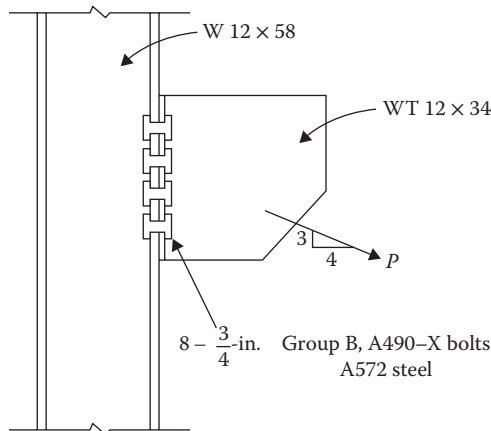


FIGURE P13.10 Combined shear-tension connection for Problem 13.15.

In Problems 13.14 through 13.16, the threads are excluded from shear planes and deformation is a consideration.

- 13.14 Design the column-to-bracket connection from Problem 13.10. Slip is permitted.
- 13.15 In the bearing-type connection shown in Figure P13.10, determine the load capacity,  $P_u$ .
- 13.16 A tensile member is subjected to service dead and live loads of 30 and 50 k, respectively, through 7/8-in. plate, as shown in Figure P13.11. Design the bearing-type connection. The steel is A572 and the bolts are 3/4-in., Group B: A490-X.

In Problems 13.17 through 13.19, the connecting surface is unpainted clean mill scale. The holes are standard size and there are no fillers.

- 13.17 Design the connection from Problem 13.14 as the slip-critical connection.
- 13.18 Solve Problem 13.15 as the slip-critical connection.

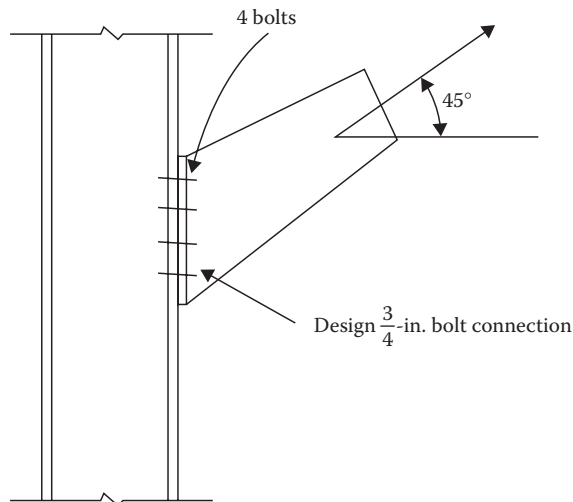


FIGURE P13.11 Combined shear-tension connection for Problem 13.16.

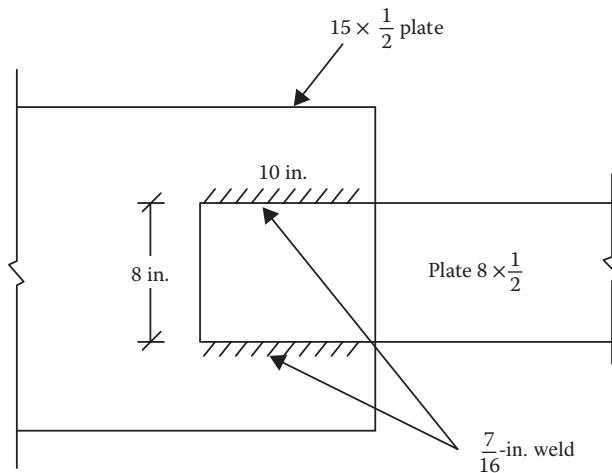
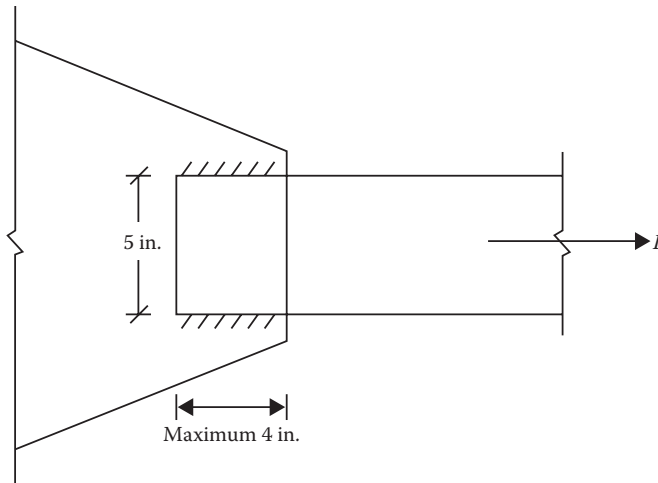
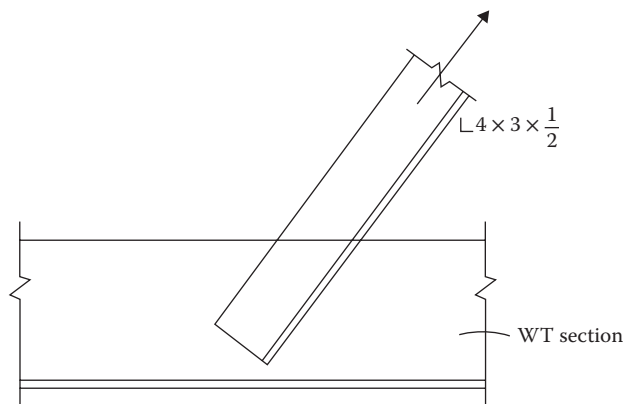


FIGURE P13.12 Welded connection for Problem 13.20.

- 13.19** Design the connection in Problem 13.16 as the slip-critical connection. Bolts are pretensioned to 40 k.
- 13.20** Determine the design strength of the connection shown in Figure P13.12. The steel is A572 and the electrodes are E 70.
- 13.21** In Problem 13.20, the applied loads are a dead load of 50 k and a live load of 150 k. For the welding shown in Figure P13.12, determine the thickness of the plates.
- 13.22** A 1/4-in.-thick flat plate is connected to a gusset plate of 5/16-in. thickness by a 3/16-in. weld as shown in Figure P13.13. The maximum longitudinal length is 4 in. Use the return (transverse) weld, if necessary. The connection has to resist a dead load of 10 k and live load of 20 k. What is the length of the weld? Use E 70 electrodes. The steel is A36.
- 13.23** Two 1/2 × 10-in. A36 plates are to be connected by a lap joint for a factored load of 80 k. Use E 80 electrodes. The steel is A36. Determine the weld size for the entire width (transverse) welding of the plate.
- 13.24** The plates in Problem 13.23 are welded as a partial-joint-penetration butt connection. The minimum effective throat width according to AISC specifications is 3/16 in. Design the connection.

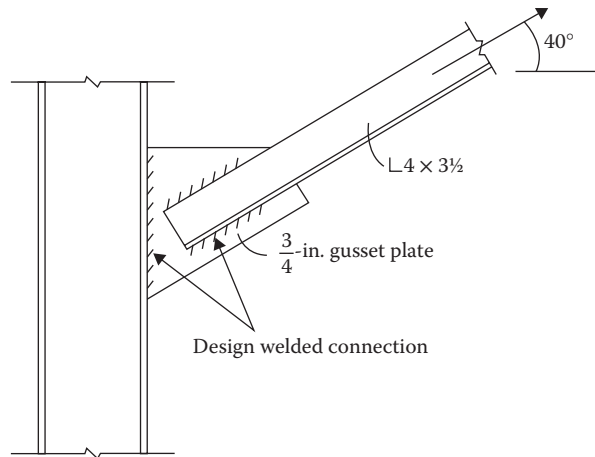


**FIGURE P13.13** Welded connection for Problem 13.22.



**FIGURE P13.14** Welded connection for Problem 13.25.

- 13.25** Design the longitudinal fillet welds to connect a  $L 4 \times 3 \times \frac{1}{2}$  angle tensile member shown in Figure P13.14 to resist a service dead load of 50 k and live load of 80 k. Use E 70 electrodes. The steel is A572.
- 13.26** A tensile member consists of 2  $L 4 \times 3 \times \frac{1}{2}$  carries a service dead load of 50 k and live load of 100 k, as shown in Figure P13.15. The angles are welded to a  $\frac{3}{4}$ -in. gusset plate, which is welded to a column flange. Design the connection of the angles to the gusset plate and the gusset plate to the column. The gusset plate is connected to the column by a CJP groove and the angles are connected by a fillet weld. Use E 70 electrodes. The steel is A572.
- 13.27** Design a single-plate shear connection for a  $W14 \times 53$  beam joining a  $W14 \times 99$  column by a  $\frac{1}{4}$ -in. plate. The factored reaction is 60 k. Use A36 steel. Use  $\frac{5}{8}$ -in. Group A: A325 bolts and E70 welds.
- 13.28** Design a single-plate shear connection for a  $W16 \times 67$  beam joining a  $W18 \times 71$  column by a  $\frac{1}{2}$ -in. plate to support a factored beam reaction of 70 k. Use  $\frac{3}{4}$ -in. Group B: A490 bolts and E80 welds. The beam and columns have A992 steel and the plate is A36 steel.



**FIGURE P13.15** Welded connection for Problem 13.26.

- 13.29** Design the connection for Problem 13.26 as a moment connection to resist a factored moment of 200 ft.-k in addition to the factored reaction of 60 k.
- 13.30** Design the connection for Problem 13.27 as a moment-resisting connection to resist a factored moment of 300 ft.-k and a factored shear force of 70 k.





# *Section IV*

---

## *Reinforced Concrete Structures*



---

# 14 Flexural Reinforced Concrete Members

## PROPERTIES OF REINFORCED CONCRETE

Concrete is a mixture of cement, sand, gravel, crushed rock, and water. Water reacts with cement in a chemical reaction known as *hydration* that sets the cement with other ingredients into a solid mass, high in compression strength. The strength of concrete depends on the proportion of the ingredients. The most important factor for concrete strength is the water–cement ratio. More water results in a weaker concrete. However, an adequate amount is needed for concrete to be workable and easy to mix. An adequate ratio is about 0.25 by weight. The process of selecting the relative amounts of ingredients for concrete to achieve a required strength at the hardened state and to be workable in the plastic (mixed) state is known as *concrete mix design*. The specification of concrete in terms of the proportions of cement, fine (sand) aggregate, and coarse (gravel and rocks) aggregate is called the *nominal mix*. For example, a 1:2:4 nominal mix has one part cement, two parts sand, and four parts gravel and rocks by volume. Nominal mixes having the same proportions could vary in strength. For this reason, another expression for specification known as the *standard mix* uses the minimum compression strength of concrete as a basis. The procedure for designing a concrete mix is a trial-and-error method. The first step is to fix the water–cement ratio for the desired concrete strength using an empirical relationship between the compressive strength and the water–cement ratio. Then, based on the characteristics of the aggregates and the proportioning desired, the quantities of the other materials comprising cement, fine aggregate, and coarse aggregate are determined.

There are some other substances that are not regularly used in the proportioning of the mix. These substances, known as *mixtures*, are usually chemicals that are added to change certain characteristics of concrete such as accelerating or slowing the setting time, improving the workability of concrete, and decreasing the water–cement ratio.

Concrete is quite strong in compression, but it is very weak in tension. In a structural system, the steel bars are placed in the tension zone to compensate for this weakness. Such concrete is known as *reinforced concrete*. At times, steel bars are also used in the compression zone to gain extra strength with a leaner concrete size as in reinforced concrete columns and doubly reinforced beams.

## COMPRESSION STRENGTH OF CONCRETE

The strength of concrete varies with time. The specified compression strength denoted as  $f'_c$  is the value that concrete attains 28 days after the placement. Beyond that stage, the increase in strength is very small. The strength  $f'_c$  ranges from 2500 to 9000 psi with a common value between 3000 and 5000 psi.

The stress–strain diagram of concrete is not linear to any appreciable extent; thus, concrete does not behave elastically over a major range. Moreover, concrete of different strengths have stress–strain curves that have different slopes. Therefore, in concrete, the modulus of elasticity cannot be ascertained directly from a stress–strain diagram.

The American Concrete Institute (ACI), which is a primary agency in the United States that prepares the national standards for structural concrete, provides the empirical relations for the modulus of elasticity based on the compression strength,  $f'_c$ .

Although the stress–strain curves have different slopes for concrete of different strengths, the following two characteristics are common to all concretes:

1. The maximum compression strength,  $f'_c$ , in all concrete is attained at a strain level of approximately 0.002 in./in.
2. The point of rupture of all curves lies in the strain range of 0.003–0.004 in./in. Thus, it is assumed that concrete fails at a strain level of 0.003 in./in.

### DESIGN STRENGTH OF CONCRETE

To understand the development and distribution of stress in concrete, let us consider a simple rectangular beam section with steel bars at the bottom (in the tensile zone), which is loaded by an increasing transverse load.

The tensile strength of concrete being small, the concrete will soon crack at the bottom at a low transverse load. The stress at this level is known as the *modulus of rupture*, and the bending moment is referred to as the *cracking moment*. Beyond this level, the tensile stress will be handled by the steel bars and the compression stress by the concrete section above the neutral axis. Concrete being a brittle (not a ductile) material, the distribution of stress within the compression zone could be considered linear only up to a moderate load level when the stress attained by concrete is less than  $1/2 f'_c$ , as shown in Figure 14.1. In this case, the stress and strain bear a direct proportional relationship.

As the transverse load increases further, the strain distribution will remain linear (Figure 14.2b) but the stress distribution will acquire a curvilinear shape similar to the shape of the stress–strain curve. As the steel bars reach the yield level, the distribution of strain and stress at this load will be as shown in Figure 14.2b and c.

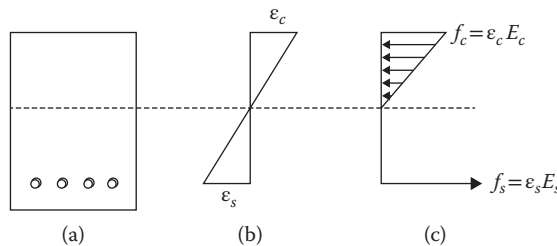


FIGURE 14.1 Stress–strain distribution at moderate loads: (a) section, (b) strain, and (c) stress.

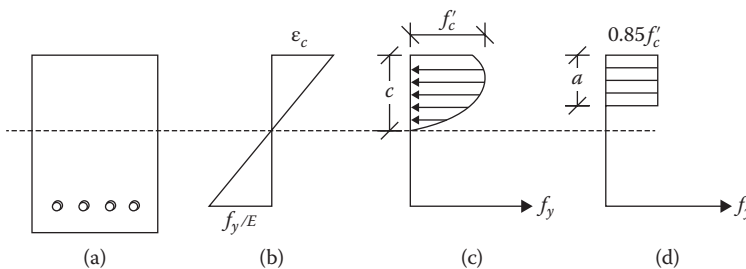


FIGURE 14.2 Stress–strain distribution at ultimate load: (a) section, (b) strain, (c) stress, and (d) equivalent stress.

For simplification, Whitney (1942) proposed a fictitious but equivalent rectangular stress distribution of intensity  $0.85f'_c$ , as shown in Figure 14.2d. This has since been adopted by the ACI. The property of this rectangular block of depth  $a$  is such that the centroid of this rectangular block is the same as the centroid of actual curved shape and that the area under the two diagrams in Figure 14.2c and d are the same. Thus, for design purposes, the ultimate compression of concrete is taken to be  $0.85f'_c$ , uniformly distributed over the depth,  $a$ .

## STRENGTH OF REINFORCING STEEL

The steel bars used for reinforcing are round, deformed bars with some form of patterned ribbed projections onto their surfaces. The bar sizes are designated from #3 through #18. For #3 to #8 sizes, the designation represents the bar diameter in one-eighths of an inch, that is, the #5 bar has a diameter of  $5/8$  in. The #9, #10, and #11 sizes have diameters that provide areas equal to the areas of the 1 in.  $\times$  1 in. square bar,  $1\frac{1}{8}$  in.  $\times$   $1\frac{1}{8}$  in. square bar, and  $1\frac{1}{4}$  in.  $\times$   $1\frac{1}{4}$  in. square bar, respectively. Sizes #14 and #18 are available only by special order. They have diameters equal to the areas of a  $1\frac{1}{2}$  in.  $\times$   $1\frac{1}{2}$  in. square bar and 2 in.  $\times$  2 in. square bar, respectively. The diameter, area, and unit weight per foot for various sizes of bars are given in Appendix D, Table D.1.

The most useful properties of reinforcing steel are the yield stress,  $f_y$ , and the modulus of elasticity,  $E$ . A large percentage of reinforcing steel bars is not made from new steel but is rolled from melted, reclaimed steel. These are available in different grades. Grade 40, Grade 50, and Grade 60 are common, where Grade 40 means the steel having a yield stress of 40 ksi and so on. The modulus of elasticity of reinforcing steel of different grades varies over a very small range. It is adopted as 29,000 ksi for all grades of steel.

Concrete structures are composed of the beams, columns, or column-beam types of structures where they are subjected to flexure, compression, or the combination of flexure and compression. The theory and design of simple beams and columns have been presented in the book.

## LOAD RESISTANCE FACTOR DESIGN BASIS OF CONCRETE

Until mid-1950, concrete structures were designed by the elastic or working stress design (WSD) method. The structures were proportioned so that the stresses in concrete and steel did not exceed a fraction of the ultimate strength, known as the *allowable* or *permissible* stresses. It was assumed that the stress within the compression portion of concrete was linearly distributed. However, beyond a moderate load when the stress level is only about one-half the compressive strength of concrete, the stress distribution in a concrete section is not linear.

In 1956, the ACI introduced a more rational method wherein the members were designed for a nonlinear distribution of stress and the full strength level was to be explored. This method was called the ultimate strength design (USD) method. Since then, the name has been changed to the *strength design* method.

The same approach is known as the load resistance factor design (LRFD) method in steel and wood structures. Thus, concrete structures were the first ones to adopt the LRFD method of design in the United States.

ACI Publication No. 318, revised numerous times, contains the codes and standards for concrete buildings. ACI 318-56 of 1956 for the first time included the codes and standards for USD in an appendix to the code. ACI 318-63 provided equal status to WSD and USD methods, bringing both of them within the main body of the code. ACI 318-02 code made USD, with the name changed to the strength design method, the mandatory method of design. ACI 318-11 provides the latest design provisions.

In the strength design method, the service loads are amplified using the load factors. The member's strength at failure, known as the theoretical or the nominal capacity, is somewhat reduced

by a strength reduction factor to represent the usable strength of the member. The amplified loads must not exceed the usable strength of member, namely,

$$\text{Amplified loads on member} \leq \text{Usable strength of member} \quad (14.1)$$

Depending upon the type of structure, the loads are the compression forces, shear forces, or bending moments.

## REINFORCED CONCRETE BEAMS

A concrete beam is a composite structure where a group of steel bars are embedded into the tension zone of the section to support the tensile component of the flexural stress. The areas of the group of bars are given in Appendix D, Table D.2. The minimum widths of beam that can accommodate a specified number of bars in a single layer are indicated in Appendix D, Table D.3. These tables are very helpful in designs.

Equation 14.1 in the case of beams takes the following form similar to wood and steel structures:

$$M_u \leq \phi M_n \quad (14.2)$$

where

$M_u$  is maximum moment due to the application of the factored loads

$M_n$  is nominal or theoretical capacity of the member

$\phi$  is strength reduction (resistance) factor for flexure

According to the flexure theory,  $M_n = F_b S$ , where  $F_b$  is the ultimate bending stress and  $S$  is the section modulus of the section. The application of this formula is straightforward for a homogeneous section for which the section modulus or the moment of inertia could be directly found. However, for a composite concrete–steel section and a nonlinear stress distribution, the flexure formula presents a problem. A different approach termed the *internal couple* method is followed for concrete beams.

In the internal couple method, two forces act on the beam cross section represented by a compressive force,  $C$ , acting on one side of the neutral axis (above the neutral axis in a simply supported beam) and a tensile force,  $T$ , acting on the other side. Since the forces acting on any cross section of the beam must be in equilibrium,  $C$  must be equal and opposite of  $T$ , thus representing a couple. The magnitude of this internal couple is the force ( $C$  or  $T$ ) times the distance  $Z$  between the two forces called the *moment arm*. This internal couple must be equal and opposite to the bending moment acting at the section due to the external loads. This is a very general and convenient method for determining the nominal moment,  $M_n$ , in concrete structures.

## DERIVATION OF THE BEAM RELATIONS

The stress distribution across a beam cross section at the ultimate load is shown in Figure 14.3 representing the concrete stress by a rectangular block as stated in the “Design Strength of Concrete” section.

The ratio of stress block and depth to the neutral axis is defined by a factor  $\beta_1$  as follows:

$$\beta_1 = \frac{a}{c} \quad (14.3)$$

Sufficient test data are available to evaluate  $\beta_1$ . According to the ACI

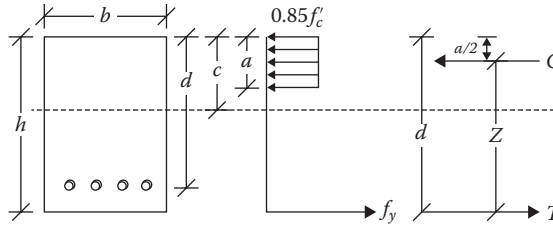


FIGURE 14.3 Internal forces and couple acting on a section.

1. For  $f'_c \leq 4000$  psi  $\beta_1 = 0.85$  (14.4a)

2. For  $f'_c > 4000$  psi but  $\leq 8000$  psi

$$\beta_1 = 0.85 - \left( \frac{f'_c - 4000}{1000} \right) (0.05) \tag{14.4b}$$

3. For  $f'_c > 8000$  psi  $\beta_1 = 0.65$  (14.4c)

With reference to Figure 14.3, since force = (stress)(area),

$$C = (0.85 f'_c)(ab) \tag{a}$$

$$T = f_y A_s \tag{b}$$

Since  $C = T$ ,

$$(0.85 f'_c)(ab) = f_y A_s \tag{c}$$

or

$$a = \frac{A_s f_y}{0.85 f'_c b} \tag{d}$$

or

$$a = \frac{\rho f_y d}{0.85 f'_c} \tag{14.5}$$

where

$$\rho = \text{steel ratio} = \frac{A_s}{bd} \tag{14.6}$$

Since moment = (force)(moment arm),

$$M_n = T \left( d - \frac{a}{2} \right) = f_y A_s \left( d - \frac{a}{2} \right) \tag{e}$$

Substituting  $a$  from Equation 14.5 and  $A_s$  from Equation 14.6 into (e), we obtain

$$M_n = \rho f_y b d^2 \left( 1 - \frac{\rho f_y}{1.7 f'_c} \right) \tag{f}$$

Substituting (f) into Equation 14.2 at equality, we obtain

$$\frac{M_u}{\phi b d^2} = \rho f_y \left( 1 - \frac{\rho f_y}{1.7 f'_c} \right) \tag{14.7}$$

Equation 14.7 is a very useful relation for analysis and design of a beam.

If we arbitrarily define the expression on the right side of Equation 14.7 as  $\bar{K}$ , called the *coefficient of resistance*, then Equation 14.7 becomes

$$M_u = \phi b d^2 \bar{K} \tag{14.8}$$

where

$$\bar{K} = \rho f_y \left( 1 - \frac{\rho f_y}{1.7 f'_c} \right) \tag{14.9}$$

The coefficient  $\bar{K}$  depends on (1)  $\rho$ , (2)  $f_y$ , and (3)  $f'_c$ . The values of  $\bar{K}$  for different combinations of  $\rho$ ,  $f_y$ , and  $f'_c$  are listed in Appendix D, Tables D.4 through D.10.

In place of Equation 14.7, these tables can be directly used in beam analyses and designs.

### STRAIN DIAGRAM AND MODES OF FAILURE

The strain diagrams in Figures 14.1 and 14.2 show a straight line variation of the concrete compression strain  $\epsilon_c$  to the steel tensile strain,  $\epsilon_s$ ; the line passes through the neutral axis. Concrete can have a maximum strain of 0.003 and the strain at which steel yields is  $\epsilon_y = f_y/E$ . When the strain diagram is such that the maximum concrete strain of 0.003 and the steel yield strain of  $\epsilon_y$  are attained at the same time, it is said to be a balanced section, as shown by the solid line labeled I in Figure 14.4.

In this case, the amount of steel and the amount of concrete balance each other out and both of these will reach the failing level (will attain the maximum strains) simultaneously. If a beam has more steel than the balanced condition, then the concrete will reach a strain level of 0.003 before the steel attains the yield strain of  $\epsilon_y$ . This is shown by condition II in Figure 14.4. The neutral axis moves down in this case.

The failure will be initiated by crushing of concrete, which will be sudden since concrete is brittle. This mode of failure in compression is undesirable because a structure will fail suddenly without any warning.

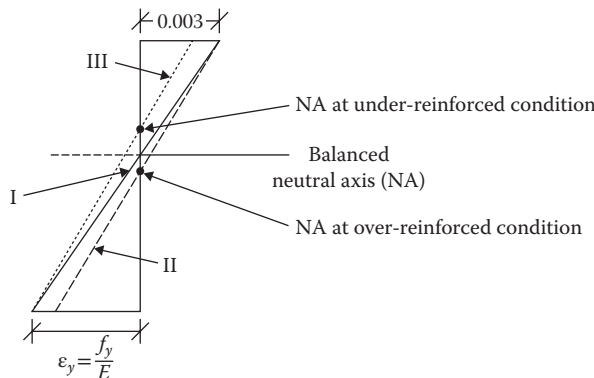


FIGURE 14.4 Strain stages in a beam.



If a beam has lesser steel than the balanced condition, then steel will attain its yield strain before the concrete can reach the maximum strain level of 0.003. This is shown by condition III in Figure 14.4. The neutral axis moves up in this case. The failure will be initiated by the yielding of the steel, which will be gradual because of the ductility of steel. This is a tensile mode of failure, which is more desirable because at least there is an adequate warning of an impending failure. The ACI recommends the tensile mode of failure or the under-reinforcement design for a concrete structure.

## BALANCED AND RECOMMENDED STEEL PERCENTAGES

To ensure the under-reinforcement conditions, the percent of steel should be less than the balanced steel percentage,  $\rho_b$ , which is the percentage of steel required for the balanced condition.

From Figure 14.4, for the balanced condition,

$$\frac{0.003}{c} = \frac{f_y/E}{d-c} \quad (a)$$

By substituting  $c = a/\beta_1$  from Equation 14.3 and  $a = \rho f_y d / 0.85 f'_c$  from Equation 14.5 and  $E = 29 \times 10^6$  psi in Equation (a), the following expression for the balanced steel is obtained:

$$\rho_b = \left( \frac{0.85\beta_1 f'_c}{f_y} \right) \left( \frac{870,000}{87,000 + f_y} \right) \quad (14.10)$$

The values for the balanced steel ratio,  $\rho_b$ , calculated for different values of  $f'_c$  and  $f_y$ , are tabulated in Appendix D, Table D.11. Although a tensile mode of failure ensues when the percent of steel is less than the balanced steel, the ACI code defines a section as tension controlled only when the tensile strain in steel  $\epsilon_t$  is equal to or greater than 0.005 as the concrete reaches its strain limit of 0.003. The strain range between  $\epsilon_y = (f_y/E)$  and 0.005 is regarded as the transition zone.

The values of the percentage of steel for which  $\epsilon_t$  is equal to 0.005 are also listed in Appendix D, Table D.11 for different grades of steel and concrete. It is recommended to design beams with a percentage of steel that is not larger than these listed values for  $\epsilon_t$  of 0.005.

If a larger percentage of steel is used than for  $\epsilon_t = 0.005$ , to be in the transition region, the strength reduction factor  $\phi$  should be adjusted, as discussed in the “Strength Reduction Factor for Concrete” section.

## MINIMUM PERCENTAGE OF STEEL

Just as the maximum amount of steel is prescribed to ensure the tensile mode of failure, a minimum limit is also set to ensure that the steel is not too small so as to cause failure by rupture (cracking) of the concrete in the tension zone. The ACI recommends the higher of the following two values for the minimum steel in flexure members:

$$(A_s)_{\min} = \frac{3\sqrt{f'_c}}{f_y} bd \quad (14.11)$$

or

$$(A_s)_{\min} = \frac{200}{f_y} bd \quad (14.12)$$

where

$b$  is width of beam

$d$  is effective depth of beam

The values of  $\rho_{\min}$ , which is  $(A_s)_{\min}/bd$ , are also listed in Appendix D, Table D.11, where a higher of the values from Equations 14.10 and 14.11 have been tabulated.

The minimum amount of steel for slabs is controlled by shrinkage and temperature requirements, as discussed in the “Specifications for Slabs” section.

## STRENGTH REDUCTION FACTOR FOR CONCRETE

In Equations 14.2 and 14.7, a strength reduction factor  $\phi$  is applied to account for all kinds of uncertainties involved in strength of materials, design and analysis, and workmanship. The values of the factor recommended by the ACI are listed in Table 14.1.

For the transition region between the compression-controlled and the tension-controlled stages when  $\epsilon_t$  is between  $\epsilon_y$  (assumed to be 0.002) and 0.005 as discussed above, the value of  $\phi$  is interpolated between 0.65 and 0.9 by the following relation:

$$\phi = 0.65 + (\epsilon_t - 0.002) \left( \frac{250}{3} \right)^* \quad (14.13)$$

The values<sup>†</sup> of  $\epsilon_t$  for different percentages of steel are also indicated in Appendix D, Tables D.4 through D.10. When it is not listed in these tables, it means that  $\epsilon_t$  is larger than 0.005.

## SPECIFICATIONS FOR BEAMS

The ACI specifications for beams are as follows:

1. *Width-to-depth ratio:* There is no code requirement for  $b/d$  ratio. From experience, the desirable  $b/d$  ratio lies between 1/2 and 2/3.
2. *Selection of steel:* After a required reinforcement area is computed, Appendix D, Table D.2 is used to select the number of bars that provide the necessary area.
3. The minimum beam widths required to accommodate multiples of various size bars are given in Appendix D, Table D.3. This is a useful design aid as demonstrated in the example.
4. The reinforcement is located at a certain distance from the surface of the concrete called the *cover*. The cover requirements in the ACI code are extensive. For beams, girders, and columns that are not exposed to weather or are not in contact with the ground, the minimum clear distance from the bottom of the steel to the concrete surface is 1/2 in. There is a

**TABLE 14.1**  
**Strength Reduction Factors**

Structural System	$\phi$
1. Tension-controlled beams and slabs	0.9
2. Compression-controlled columns	
Spiral	0.70
Tied	0.65
3. Shear and torsion	0.75
4. Bearing on concrete	0.65

\* For spiral reinforcement this is  $\phi = 0.70 + (\epsilon_t - 0.002)(250/3)$ .

†  $\epsilon_t$  is calculated by the formula  $\epsilon_t = (0.00255 f'_c \beta_1 / \rho f_y) - 0.003$ .

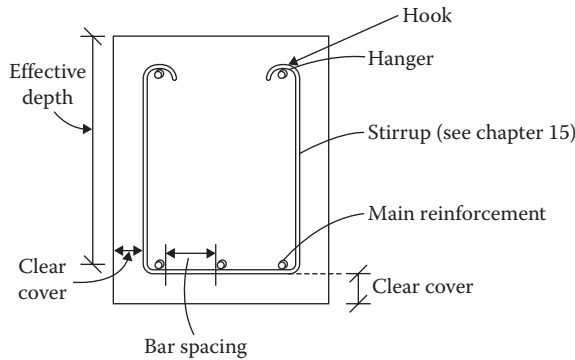


FIGURE 14.5 Sketch of beam specifications.

**TABLE 14.2**  
**First Estimate of Beam Weight**

Design Moment, $M_u$ (ft.-k)	Estimated Weight (lb/ft.)
$\leq 200$	300
$> 200$ but $\leq 300$	350
$> 300$ but $\leq 400$	400
$> 400$ but $\leq 500$	450
$> 500$	500

minimum cover requirement of  $1\frac{1}{2}$  in. from the outermost longitudinal bars to the edge toward the width of the beam, as shown in Figure 14.5.

5. *Bar spacing*: The clear spacing between the bars in a single layer should not be less than any of the following:
  - 1 in.
  - The bar diameter
  - $1\frac{1}{3} \times$  maximum aggregate size
6. *Bars placement*: If the bars are placed in more than one layer, those in the upper layers are required to be placed directly over the bars in the lower layers and the clear distance between the layers must not be less than 1 in.
7. *Concrete weight*: Concrete is a heavy material. The weight of the beam is significant. An estimated weight should be included. If it is found to be appreciably less than the weight of the section designed, then the design should be revised. For a good estimation of concrete weight, Table 14.2 could be used as a guide.

**ANALYSIS OF BEAMS**

Analysis relates to determining the factored or service moment or the load capacity of a beam of known dimensions and known reinforcement.

The analysis procedure follows:

1. Calculate the steel ratio from Equation 14.6:

$$\rho = \frac{A_s}{bd}$$

- Calculate  $(A_s)_{\min}$  from Equations 14.11 and 14.12 or use Appendix D, Table D.11. Compare this to the  $A_s$  of the beam to ensure that it is more than the minimum.
- For known  $\rho$ , read  $\epsilon_t$  from Appendix D, Tables D.4 through D.10 or by the formula in the footnote of Equation 14.13. If no value is given, then  $\epsilon_t = 0.005$ . If  $\epsilon_t < 0.005$ , determine  $\phi$  from Equation 14.13.
- For known  $\rho$ , compute  $\bar{K}$  from Equation 14.9 or read the value from Appendix D, Tables D.4 through D.10.
- Calculate  $M_u$  from Equation 14.7:

$$M_u = \phi b d^2 \bar{K}$$

- Break down into the loads if required.

### Example 14.1

The loads on a beam section are shown in Figure 14.6. Determine whether the beam is adequate to support the loads.  $f'_c = 4,000$  psi and  $f_y = 60,000$  psi.

### SOLUTION

#### A. Design loads and moments

- Weight of beam/ft. =  $(12/12) \times (20/12) \times 1 \times 150 = 250$  lb/ft. or 0.25 k/ft.
- Factored dead load,  $w_u = 1.2 (1.25) = 1.5$  k/ft.
- Factored live load,  $P_u = 1.6 (15) = 24$  k
- Design moment due to dead load =  $w_u L^2/8 = 1.5(20)^2/8 = 75$  ft.-k
- Design moment due to live load =  $P_u L/4 = 24(20)/4 = 120$  ft.-k
- Total design moment,  $M_u = 195$  ft.-k
- $A_s = 3.16$  in.<sup>2</sup> (from Appendix D, Table D.2 for 4 bars of size #8)
- $\rho = A_s/bd = 3.16/12 \times 17 = 0.0155$
- $(A_s)_{\min} = 0.0033$  (from Appendix D, Table D.11)  $< 0.0155$  **OK**
- $\epsilon_t \geq 0.005$  (value not listed in Appendix D, Table D.9),  $\phi = 0.9$
- $\bar{K} = 0.8029$  ksi (for  $\rho = 0.0155$  from Appendix D, Table D.9)
- $M_u = \phi b d^2 \bar{K} = (0.9)(12)(17)^2(0.8029) = 2506$  in.-k or 209 ft.-k  $> 195$  ft.-k **OK**

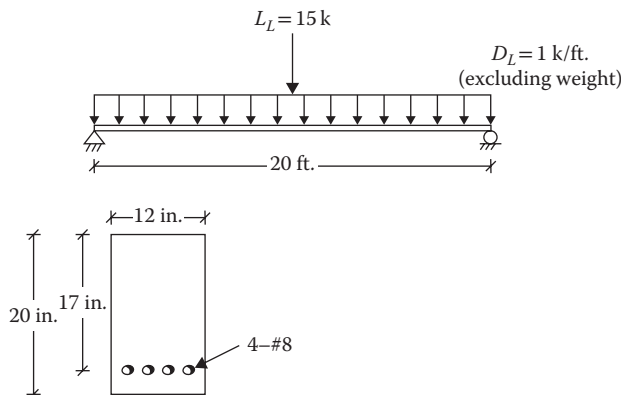


FIGURE 14.6 Beam for Example 14.1.

## DESIGN OF BEAMS

In wood beam design in Chapter 7 and steel beam design in Chapter 11, beams were designed for bending moment capacity and checked for shear and deflection.

In concrete beams, shear is handled independently, as discussed in Chapter 16. For deflection, the ACI stipulates that when certain depth requirements are met, deflection will not interfere with the use or cause damage to the structure. These limiting values are given in Table 14.3 for normal weight (120–150 lb/ft.<sup>3</sup>) concrete and Grade 60 steel. For other grade concrete and steel, the adjustments are made as indicated in the footnotes to Table 14.3.

When the minimum depth requirement is met, deflection needs not be computed. For members of lesser thickness than those listed in Table 14.3, the deflections should be computed to check for safe limits. This book assumes that the minimum depth requirement is satisfied.

Beam design falls into the two categories discussed below.

### DESIGN FOR REINFORCEMENT ONLY

When a beam section has been fixed from architectural or any other consideration, only the amount of steel has to be selected. The procedure is as follows:

1. Determine the design moment,  $M_u$  including the beam weight for various critical load combinations.
2. Using  $d = h - 3$  and  $\phi = 0.9$ , calculate the required  $\bar{K}$  from Equation 14.8 expressed as

$$\bar{K} = \frac{M_u}{\phi b d^2}$$

3. From Appendix D, Tables D.4 through D.10, find the value of  $\rho$  corresponding to  $\bar{K}$  of step 2. From the same tables, confirm that  $\epsilon_t \geq 0.005$ . If  $\epsilon_t < 0.005$ , reduce  $\phi$  by Equation 14.13, recompute  $\bar{K}$ , and find the corresponding  $\rho$ .
4. Compute the required steel area  $A_s$  from Equation 14.6:
 
$$A_s = \rho b d$$
5. Check for the minimum steel  $A_{s(\min)}$  from Appendix D, Table D.11.
6. Select the bar size and the number of bars from Appendix D, Table D.2. From Appendix D, Table D.3, check whether the selected steel (size and number) can fit into width of the beam, preferably in a single layer. They can be arranged in two layers. Check to confirm that the actual depth is at least equal to  $h - 3$ .
7. Sketch the design.

**TABLE 14.3**

### Minimum Thickness of Beams and Slabs for Normal Weight Concrete and Grade 60 Steel

Member	Minimum Thickness, $h$ (in.)			
	Simply Supported	Cantilever	One End Continuous	Both Ends Continuous
Beam	$L/16$	$L/18.5$	$L/21$	$L/8$
Slab (one-way)	$L/20$	$L/24$	$L/28$	$L/10$

Notes:  $L$  is the span in inches.

For lightweight concrete of unit weight 90–120 lb/ft.<sup>3</sup>, the table values should be multiplied by  $(1.65 - 0.005W_c)$  but not less than 1.09, where  $W_c$  is the unit weight in lb/ft.<sup>3</sup>

For other than Grade 60 steel, the table value should be multiplied by  $(0.4 + f_y/100)$ , where  $f_y$  is in ksi.

**Example 14.2**

Design a rectangular reinforced beam to carry a service dead load of 1.6 k/ft. and a live load of 1.5 k/ft. on a span of 20 ft. The architectural consideration requires the width to be 10 in. and depth to be 24 in. Use  $f'_c = 3,000$  psi and  $f_y = 60,000$  psi.

**SOLUTION**

1. Weight of beam/ft. =  $(10/12)(24/12) \times 1 \times 150 = 250$  lb/ft. or 0.25 k/ft.
2.  $w_u = 1.2(1.6 + 0.25) + 1.6(1.5) = 4.62$  k/ft.
3.  $M_u = w_u L^2/8 = 4.62(20)^2/8 = 231$  ft.-k or 2772 in.-k
4.  $d = 24 - 3 = 21$  in.
5.  $\bar{K} = 2772/(0.9)(10)(21)^2 = 0.698$  ksi
6.  $\rho = 0.0139$   $\epsilon_t = 0.0048$  (from Appendix D, Table D.6)
7. From Equation 14.13,  $\phi = 0.65 + (0.0048 - 0.002)(250/3) = 0.88$
8. Revised  $\bar{K} = 2772/(0.88)(10)(21)^2 = 0.714$  ksi
9. Revised  $\rho = 0.0143$  (from Appendix D, Table D.6)\*
10.  $A_s = \rho b d = (0.0143)(10)(21) = 3$  in.<sup>2</sup>
11.  $A_{s(min)} = 0.0033$  (from Appendix D, Table D.11) < 0.0143 **OK**
12. Selection of steel

Bar Size	No. of Bars	$A_s$ , from Appendix D, Table D.2	Minimum Width in One Layer from Appendix D, Table D.3
#6	7	3.08	15 NG
#7	5	3.0	12.5 NG
#9	3	3.0	9.5 OK

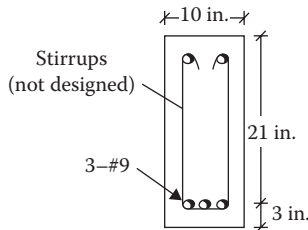
Select three bars of #9

13. The beam section is shown in Figure 14.7.

**DESIGN OF BEAM SECTION AND REINFORCEMENT**

The design comprises determining the beam dimensions and selecting the amount of steel. The procedure is as follows:

1. Determine the design moment,  $M_u$ , including the beam weight for various critical load combinations.
2. Select the steel ratio  $\rho$  corresponding to  $\epsilon_t = 0.005$  from Appendix D, Table D.11.
3. From Appendix D, Tables D.4 through D.10, find  $\bar{K}$  for the steel ratio of step 2.



**FIGURE 14.7** Beam section for Example 14.2.

\* For  $\bar{K} = 0.714$  ksi,  $\epsilon_t = 0.0046$ .  $\phi$  will need a minor adjustment again.

4. For  $b/d$  ratio of 1/2 and 2/3, find two values of  $d$  from the following expression:

$$d = \left[ \frac{M_u}{\phi(b/d)\bar{K}} \right]^{1/3*} \quad (14.14)$$

5. Select the effective depth to be between the two values of step 4  
 6. If the depth from Table 14.3 is larger, use that value.  
 7. Determine the corresponding width  $b$  from

$$b = \frac{M_u}{\phi d^2 \bar{K}} \quad (14.15)$$

8. Estimate  $h$  and compute the weight of the beam. If this is excessive as compared to the assumed value of step 1, repeat steps 1 through 7  
 9. From now on, follow steps 4 through 7 of the design procedure in the "Design for Reinforcement Only" section for the selection of steel.

### Example 14.3

Design a rectangular reinforced beam for the service loads shown in Figure 14.8. Use  $f'_c = 3,000$  psi and  $f_y = 60,000$  psi.

### SOLUTION

1. Factored dead load,  $w_u = 1.2(1.5) = 1.8$  k/ft.
2. Factored live load,  $P_u = 1.6(20) = 32$  k
3. Design moment due to dead load =  $w_u L^2/8 = 1.8(30)^2/8 = 202.5$  ft.-k
4. Design moment due to live load =  $P_u L/3 = 32(30)/3 = 320$  ft.-k
5. Total moment,  $M_u = 522.5$  ft.-k
6. Weight of beam from Table 14.2, 0.5 k/ft.
7. Factored dead load including weight  $1.2(1.5 + 0.5) = 2.4$  k/ft.
8. Moment due to dead load =  $2.4(30)^2/8 = 270$  ft.-k
9. Total design moment = 590 ft.-k or 7080 in.-k
10.  $\rho = 0.0136$  (from Appendix D, Table D.11 for  $\epsilon_t = 0.005$ )
11.  $\bar{K} = 0.684$  ksi (from Appendix D, Table D.6)
- 12.

Select $b/d$ ratio	Calculate $d$ from Equation 14.14
1/2	28.3 <sup>a</sup>
2/3	25.8

$$^a [7080/0.9(1/2)(0.684)]^{1/3}$$

13. Depth for deflection (from Table 14.3)

$$h = \frac{L}{16} = \frac{30 \times 12}{16} = 22.5 \text{ in.}$$

$$\text{or } d = h - 3 = 22.5 - 3 = 19.5 \text{ in.}$$

Use  $d = 27$  in.

\* This relation is the same as  $M_u = \phi b d^2 \bar{K}$  or  $M_u = \phi (b/d) d^3 \bar{K}$ .

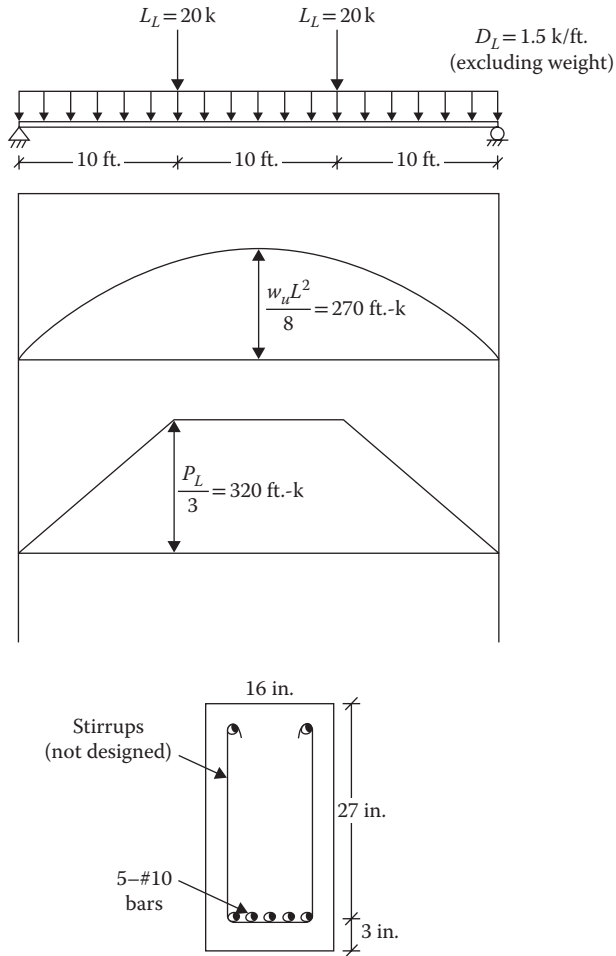


FIGURE 14.8 Loads, bending moments, and beam section for Example 14.3.

14. From Equation 14.15

$$b = \frac{7080}{(0.9)(27)^2(0.684)} = 15.75 \text{ in.}, \text{ use } 16 \text{ in.}$$

15.  $h = d + 3 = 30$  in.

Weight of beam/ft. =  $(16/12)(30/12) \times 1 \times 150 = 500$  lb/ft. or 0.50 k/ft. **OK**

16.  $A_s = \rho b d = (0.0136)(16)(27) = 5.88 \text{ in.}^2$

17. Selection of steel

Bar Size	No. of Bars	$A_s$ , from Appendix D, Table D.2	Minimum Width in One Layer from Appendix D, Table D.3
#9	6	6.00	16.5 NG
#10	5	6.35	15.5

Select five bars of #10



## ONE-WAY SLAB

Slabs are the concrete floor systems supported by reinforced concrete beams, steel beams, concrete columns, steel columns, concrete walls, or masonry walls. If they are supported on two opposite sides only, they are referred to as *one-way slabs* because the bending is in one direction only, perpendicular to the supported edge. When slabs are supported on all four edges, they are called *two-way slabs* because the bending is in both directions. A rectangular floor plan has slab supported on all four sides. However, if the long side is two or more times of the short side, the slab could be considered a one-way slab spanning the short direction.

A one-way slab is analyzed and designed as 12 in. wide beam segments placed side by side having a total depth equal to the slab thickness, as shown in Figure 14.9.

The amount of steel computed is considered to exist in 12 in. width on average. Appendix D, Table D.12 is used for this purpose; it indicates for the different bar sizes the center-to-center spacing of the bars for a specified area of steel. The relationship is as follows:

$$\text{Bar spacing center to center} = \frac{\text{Required steel area}}{\text{Area of 1 bar}} \times 12 \quad (14.16)$$

## SPECIFICATIONS FOR SLABS

The ACI specifications for one-way slab follow:

1. *Thickness*: Table 14.3 indicates the minimum thickness for one-way slabs where deflections are not to be calculated. The slab thickness is rounded off to the nearest 1/4 in. on the higher side for slabs up to 6 in. and to the nearest 1/2 in. for slabs thicker than 6 in.
2. *Cover*: (1) For slabs that are not exposed to the weather or are not in contact with the ground, the minimum cover is 3/4 in. for #11 and smaller bars and (2) for slabs exposed to the weather or in contact with the ground, the minimum cover is 3 in.
3. *Spacing of bars*: The main reinforcement should not be spaced on center to center more than (1) three times the slab thickness or (2) 18 in., whichever is smaller.
4. *Shrinkage steel*: Some steel is placed in the direction perpendicular to the main steel to resist shrinkage and temperature stresses. The minimum area of such steel is
  - a. For Grade 40 or 50 steel, shrinkage  $A_s = 0.002bh$ .
  - b. For Grade 60 steel, shrinkage  $A_s = 0.0018bh$ , where  $b = 12$  in.

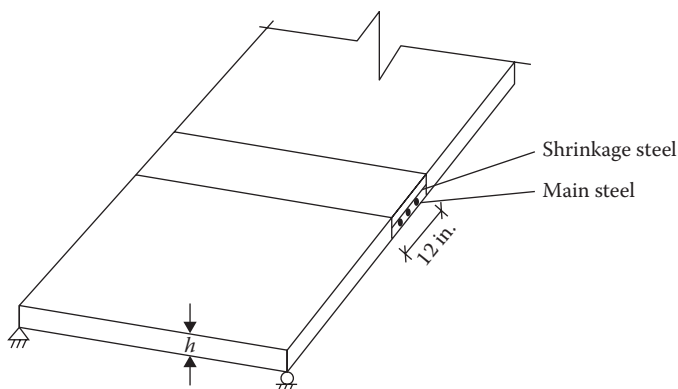


FIGURE 14.9 Simply supported one-way slab.

The shrinkage and temperature steel should not be spaced farther apart than (1) five times the slab thickness or (2) 18 in., whichever is smaller.

5. *Minimum main reinforcement:* The minimum amount of main steel should not be less than the shrinkage and temperature steel.

## ANALYSIS OF ONE-WAY SLAB

The analysis procedure is as follows:

1. For the given bar size and spacing, read  $A_s$  from Appendix D, Table D.12.
2. Find the steel ratio:

$$\rho = \frac{A_s}{bd} \quad \text{where } b = 12 \text{ in.}, d = h - 0.75 \text{ in.} - 1/2 (\text{bar diameter})^*$$

3. Check for the minimum shrinkage steel and also that the main reinforcement  $A_s$  is more than  $A_{s(\min)}$ :

$$A_{s(\min)} = 0.002bh$$

4. For  $\rho$  of step 2, read  $\bar{K}$  and  $\epsilon_t$  (if given in the same appendices) from Appendix D, Tables D.4 through D.10.
5. Correct  $\phi$  from Equation 14.13 if  $\epsilon_t < 0.005$ .
6. Find out  $M_u$  as follows and convert to loads if necessary:

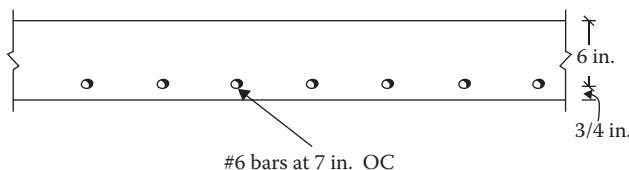
$$M_u = \phi b d^2 \bar{K}$$

### Example 14.4

The slab of an interior floor system has a cross section as shown in Figure 14.10. Determine the service live load that the slab can support in addition to its own weight on a span of 10 ft.  $f'_c = 3,000$  psi,  $f_y = 40,000$  psi.

## SOLUTION

1.  $A_s = 0.75 \text{ in.}^2$  (from Appendix D, Table D.12)
2.  $d = (6 - 1/2)(0.75) = 5.625 \text{ in.}$  and  $\rho = A_s/bd = 0.75/(12)(5.625) = 0.011$
3.  $A_{s(\min)} = 0.002bh = (0.002)(12)(6.75) = 0.162 < 0.75 \text{ in.}^2$  **OK**
4.  $\bar{K} = 0.402$  (from Appendix D, Table D.4),  $\epsilon_t > 0.005$  for  $\rho = 0.011$
5.  $M_u = \phi b d^2 \bar{K} = (0.9)(12)(5.625)^2(0.402) = 137.37 \text{ in.-k}$  or  $11.45 \text{ ft.-k}$
6.  $M_u = w_u L^2/8$  or  $w_u = 8M_u/L^2 = 8(11.45)/10^2 = 0.916 \text{ k/ft.}$
7. Weight of a slab/ft. =  $(12/12)(6.75/12)(1)(150/1000) = 0.084 \text{ k/ft.}$
8.  $w_u = 1.2(w_D) + 1.6(w_L)$  or  $0.916 = 1.2(0.084) + 1.6 w_L$  or  $w_L = 0.51 \text{ k/ft.}$   
Since the slab width is 12 in., live load is  $0.51 \text{ k/ft.}^2$



**FIGURE 14.10** Cross section of slab of a floor system (perpendicular to span) for Example 14.4.

\* For slabs laid on the ground,  $d = h - 3 - 1/2$  (bar diameter).

**DESIGN OF ONE-WAY SLAB**

1. Determine the minimum  $h$  from Table 14.3. Compute the slab weight/ft. for  $b = 12$  in.
2. Compute the design moment  $M_u$ . The unit load per square foot automatically becomes load/ft. since the slab width = 12 in.
3. Calculate an effective depth,  $d$ , from

$$d = h - \text{cover} - 1/2 \times \text{assumed bar diameter}$$

4. Compute  $\bar{K}$  assuming  $\phi = 0.90$ ,

$$\bar{K} = \frac{M_u}{\phi b d^2}$$

5. From Appendix D, Tables D.4 through D.10, find the steel ratio  $\rho$  and note the value of  $\epsilon_t$  (if  $\epsilon_t$  is not listed then  $\epsilon_t > 0.005$ )
6. If  $\epsilon_t < 0.005$ , correct  $\phi$  from Equation 14.13 and repeat steps 4 and 5
7. Compute the required  $A_s$ :

$$A_s = \rho b d$$

8. From the table in Appendix D, Table D.12, select the main steel satisfying the condition that the bar spacing is  $\leq 3h$  or 18 in.
9. Select shrinkage and temperature of steel:

$$\text{Shrinkage } A_s = 0.002bh \text{ (Grade 40 or 50 steel)}$$

or

$$0.0018bh \text{ (Grade 60 steel)}$$

10. From Appendix D, Table D.12, select size and spacing of shrinkage steel with a maximum spacing of  $5h$  or 18 in., whichever is smaller.
11. Check that the main steel area of step 7 is not less than the shrinkage steel area of step 9.
12. Sketch the design.

**Example 14.5**

Design an exterior one-way slab exposed to the weather to span 12 ft. and to carry a service dead load of 100 pounds per square foot (psf) and live load of 300 psf in addition to the slab weight. Use  $f'_c = 3,000$  psi and  $f_y = 40,000$  psi.

**SOLUTION**

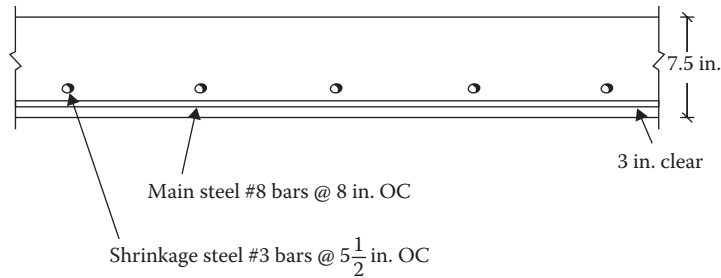
1. Minimum thickness for deflection from Table 14.3

$$h = \frac{L}{20} = \frac{12(12)}{20} = 7.2 \text{ in.}$$

For exterior slab use  $h = 10$  in.

2. Weight of slab =  $(12/12)(10/12)(1)(150/1000) = 0.125$  k/ft.
3.  $w_u = 1.2(0.1 + 0.125) + 1.6(0.3) = 0.75$  k/ft.
4.  $M_u = w_u L^2/8 = 13.5$  ft.-k or 162 in.-k
5. Assuming #8 size bar (diameter = 1 in.)

$$\begin{aligned} d &= h - \text{cover} - 1/2(\text{bar diameter}) \\ &= 10 - 3 - 1/2(1) = 6.5 \text{ in.} \end{aligned}$$



**FIGURE 14.11** Design section for Example 14.5.

6.  $\bar{K} = (M_u)/(\phi bd^2) = (162)/(0.9)(12)(6.5)^2 = 0.355$
7.  $\rho = 0.014$ ,  $\epsilon_t > 0.005$  (from Appendix D, Table D.4)
8.  $A_s = \rho bd = (0.014)(12)(6.5) = 1.09 \text{ in.}^2/\text{ft}$ .  
Provide #8 size bars @ 8 in. on center (from Appendix D, Table D.12),  $A_s = 1.18 \text{ in.}^2$
9. Check for maximum spacing
  - a.  $3h = 3(10) = 30 \text{ in.}$
  - b.  $18 \text{ in.} > 8 \text{ in.}$  **OK**
10. Shrinkage and temperature steel
 
$$A_s = 0.002bh$$

$$= 0.002(12)(7.5) = 0.18 \text{ in.}^2/\text{ft.}$$
 Provide #3 size bars @ 5 $\frac{1}{2}$  in. on center (from Table D.12)  $A_s = 0.24 \text{ in.}^2$
11. Check for maximum spacing of shrinkage steel
  - a.  $5h = 5(10) = 50 \text{ in.}$
  - b.  $18 \text{ in.} > 5\frac{1}{2} \text{ in.}$  **OK**
12. Main steel > shrinkage steel **OK**
13. A designed section is shown in Figure 14.11

## PROBLEMS

- 14.1** A beam cross section is shown in Figure P14.1. Determine the service dead load and live load/ft. for a span of 20 ft. The service dead load is one-half of the live load.  $f'_c = 4,000 \text{ psi}$ ,  $f_y = 60,000 \text{ psi}$ .
- 14.2** Calculate the design moment for a rectangular reinforced concrete beam having a width of 16 in. and an effective depth of 24 in. The tensile reinforcement is five bars of size #8.  $f'_c = 4,000 \text{ psi}$ ,  $f_y = 40,000 \text{ psi}$ .
- 14.3** A reinforced concrete beam has a cross section shown in Figure P14.2 for a simple span of 25 ft. It supports a dead load of 2 k/ft. (excluding beam weight) and live load of 3 k/ft. Is the beam adequate?  $f'_c = 4,000 \text{ psi}$ ,  $f_y = 60,000 \text{ psi}$ .
- 14.4** Determine the dead load (excluding the beam weight) for the beam section shown in Figure P14.3 of a span of 30 ft. The service dead load and live load are equal.  $f'_c = 5,000 \text{ psi}$ ,  $f_y = 60,000 \text{ psi}$ .
- 14.5** The loads on a beam and its cross section are shown in Figure P14.4. Is this beam adequate?  $f'_c = 4,000 \text{ psi}$ ,  $f_y = 50,000 \text{ psi}$ .
- 14.6** Design a reinforced concrete beam to resist a factored design moment of 150 ft.-k. It is required that the beam width be 12 in. and the overall depth be 24 in.  $f'_c = 3,000 \text{ psi}$ ,  $f_y = 60,000 \text{ psi}$ .
- 14.7** Design a reinforced concrete beam of a span of 30 ft. The service dead load is 0.85 k/ft. (excluding weight) and live load is 1 k/ft. The beam has to be 12 in. wide and 26 in. deep.  $f'_c = 4,000 \text{ psi}$ ,  $f_y = 60,000 \text{ psi}$ .

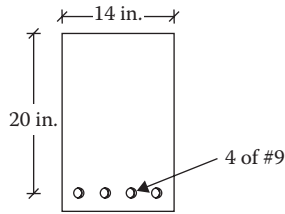


FIGURE P14.1 Beam section for Problem 14.1.

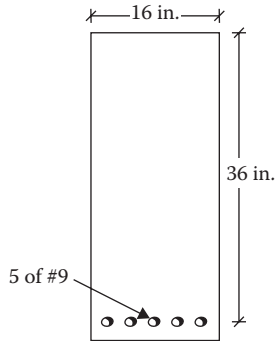


FIGURE P14.2 Beam section for Problem 14.3.

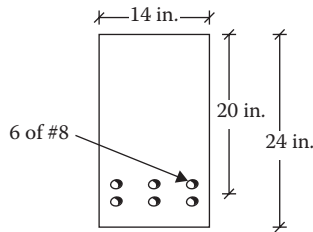


FIGURE P14.3 Beam section for Problem 14.4.

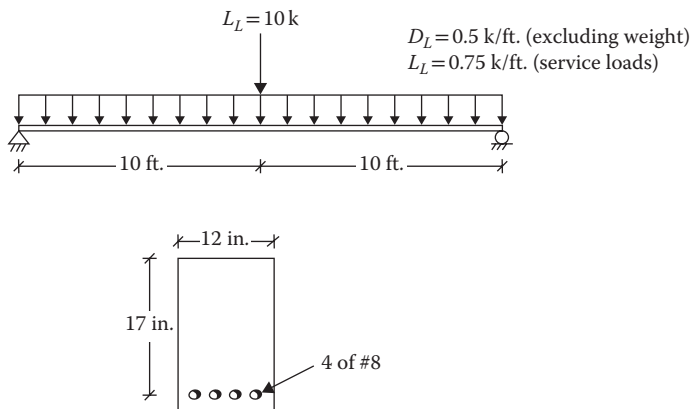


FIGURE P14.4 Loads and section for Problem 14.5.

- 14.8 Design a reinforced beam for a simple span of 30 ft. There is no dead load except the weight of the beam and the service live load is 1.5 k/ft. The beam can be 12 in. wide and 28 in. overall depth.  $f'_c = 5,000$  psi,  $f_y = 60,000$  psi.
- 14.9 A beam carries the service loads shown in Figure P14.5. From architectural consideration, the beam width is 12 in. and the overall depth is 20 in. Design the beam reinforcement.  $f'_c = 4,000$  psi,  $f_y = 60,000$  psi.
- 14.10 In Problem 14.9, the point dead load has a magnitude of 6.5 k (instead of 4 k). Design the reinforcement for a beam of the same size for Problem 14.9.  $f'_c = 4,000$  psi,  $f_y = 60,000$  psi.
- 14.11 Design a rectangular reinforced beam for a simple span of 30 ft. The uniform service loads are dead load of 1.5 k/ft. (excluding beam weight) and live load of 2 k/ft.  $f'_c = 4,000$  psi,  $f_y = 60,000$  psi.
- 14.12 Design a simply supported rectangular reinforced beam for the service loads shown in Figure P14.6. Provide the reinforcement in a single layer. Sketch the design.  $f'_c = 4,000$  psi,  $f_y = 60,000$  psi.
- 14.13 Design a simply supported rectangular reinforced beam for the service loads shown in Figure P14.7. Provide the reinforcement in a single layer. Sketch the design.  $f'_c = 3,000$  psi,  $f_y = 40,000$  psi.
- 14.14 Design the cantilever rectangular reinforced beam shown in Figure P14.8. Provide a maximum of #8 size bars, in two rows if necessary. Sketch the design.  $f'_c = 3,000$  psi,  $f_y = 50,000$  psi.  
[Hint: Reinforcement will be at the top. Design as usual.]

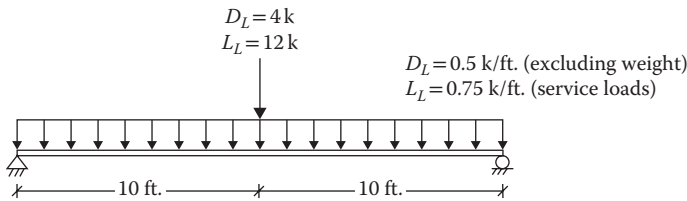


FIGURE P14.5 Loads on beam for Problem 14.9.

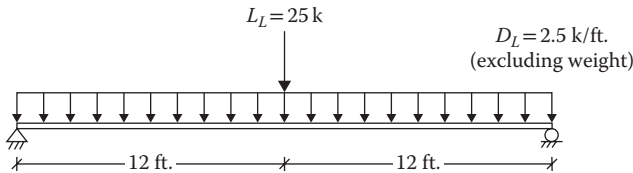


FIGURE P14.6 Loads on beam for Problem 14.12.

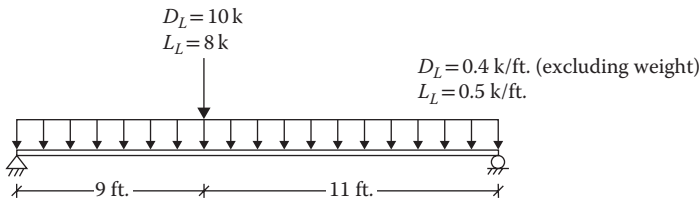


FIGURE P14.7 Loads on beam for Problem 14.13.

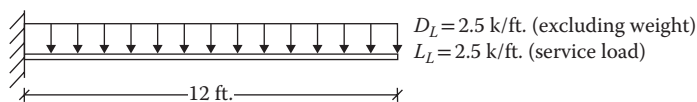


FIGURE P14.8 Cantilevered beam for Problem 14.14.

- 14.15 Design the beam for the floor shown in Figure P14.9. The service dead load (excluding beam weight) is 100 psf and live load is 300 psf.  $f'_c = 3,000$  psi,  $f_y = 40,000$  psi.
- 14.16 A 9 in. thick one-way interior slab supports a service live load of 500 psf on a simple span of 15 ft. The main reinforcement consists of #7 size bars at 7 in. on center. Check whether the slab can support the load in addition to its own weight. Use  $f'_c = 3,000$  psi,  $f_y = 60,000$  psi.
- 14.17 A one-way interior slab shown in Figure P14.10 spans 12 ft. Determine the service load that the slab can carry in addition to its own weight.  $f'_c = 3,000$  psi,  $f_y = 40,000$  psi.
- 14.18 A one-way slab, exposed to the weather, has a thickness of 9 in. The main reinforcement consists of #8 size bars at 7 in. on center. The slab carries a dead load of 500 psf in addition to its own weight on a span of 10 ft. What is the service live load that the slab can carry?  $f'_c = 4,000$  psi,  $f_y = 60,000$  psi.
- 14.19 A 8 1/2 in. thick one-way slab interior spans 10 ft. It was designed with the reinforcement of #6 size bars at 6.5 in. on center, to be placed with a cover of 0.75 in. However, the same steel was misplaced at a clear distance of 2 in. from the bottom. How much is the reduction in the capacity of the slab reduced to carry the superimposed service live load in addition to its own weight?  $f'_c = 4,000$  psi,  $f_y = 60,000$  psi.
- 14.20 Design a simply supported one-way interior slab to span 15 ft. and to support the service dead and live loads of 150 and 250 psf in addition to its own weight. Sketch the design.  $f'_c = 4,000$  psi,  $f_y = 50,000$  psi.
- 14.21 Design the concrete floor slab shown in Figure P14.11. Sketch the design.  $f'_c = 3,000$  psi,  $f_y = 40,000$  psi.

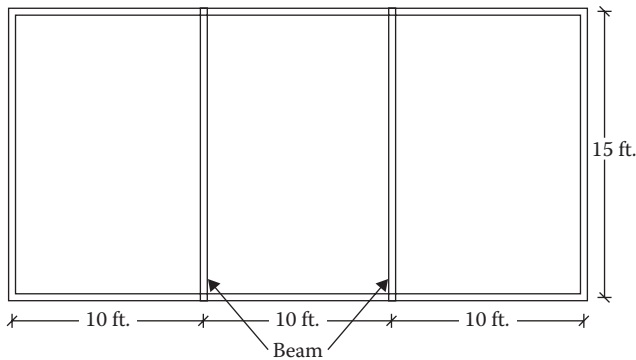


FIGURE P14.9 Floor system for Problem 14.15.

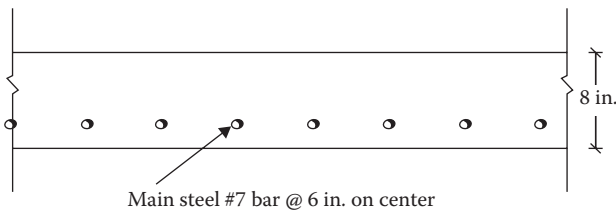


FIGURE P14.10 Cross section of slab for Problem 14.17.

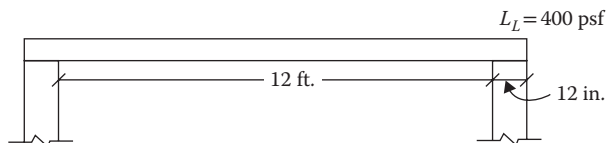


FIGURE P14.11 One-way slab for Problem 14.21.

- 14.22** Design the slab of the floor system in Problem 14.15.  $f'_c = 3,000$  psi,  $f_y = 40,000$  psi.  
[Hint: The slab weight is included in the service dead load.]
- 14.23** For Problem 14.15, design the thinnest slab so that the strain in steel is not less than 0.005.  
 $f'_c = 3,000$  psi,  $f_y = 40,000$  psi.
- 14.24** Design a balcony slab exposed to the weather. The cantilevered span is 8 ft. and the service live load is 100 psf. Use the reinforcement of #5 size bars. Sketch the design.  
 $f'_c = 4,000$  psi,  $f_y = 60,000$  psi.  
[Hint: Reinforcement is placed on top. For the thickness of slab, in addition to the provision of main steel and shrinkage steel, at least 3 in. of depth (cover) should exist over and below the steel.]



---

# 15 Doubly and T Reinforced Concrete Beams

## DOUBLY REINFORCED CONCRETE BEAMS

Sometimes the aesthetics or architectural considerations necessitate a small beam section that is not adequate to resist the moment imposed on the beam. In such cases, the additional moment capacity could be achieved by adding more steel on both the compression and tensile sides of the beam. Such sections are known as *doubly reinforced* beams. The compression steel also makes beams more ductile and more effective in reducing deflections.

The moment capacity of doubly reinforced beams is assumed to comprise two parts as shown in Figure 15.1. One part is due to the compression concrete and tensile steel, shown in Figure 15.1b as described in Chapter 14. The other part is due to the compression steel and the additional tensile steel shown in Figure 15.1c.

Thus,

$$A_s = A_{s1} + A_{s2}$$

$$M_u = M_{u1} + M_{u2}$$

$$M_{u1} = \phi A_{s1} f_y \left( d - \frac{a}{2} \right)$$

and

$$M_{u2} = \phi A_{s2} f_y (d - d')$$

The combined capacity is given by

$$M_u = \phi A_{s1} f_y \left( d - \frac{a}{2} \right) + \phi A_{s2} f_y (d - d') \quad (15.1)$$

where

$\phi$  is resistance factor

$d$  is effective depth

$A_s$  is area of steel on the tensile side of the beam;  $A_s = A_{s1} + A_{s2}$

$A'_s$  is area of steel on the compression side of the beam

The compression steel area  $A'_s$  depends on the compression stress level  $f'_s$ , which can be the yield stress  $f_y$  or less. The value of  $f'_s$  is decided by the strain in concrete at compression steel level, which in turn depends upon the location of the neutral axis.

From the strain diagram, when concrete attains the optimal strain level at the top as shown in Figure 15.2,

$$\epsilon'_s = \frac{0.003 (c - d')}{c} \quad (15.2)$$

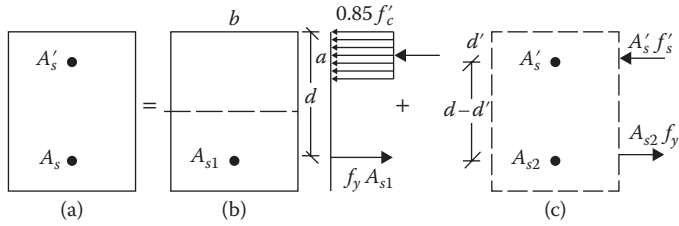


FIGURE 15.1 Moment capacity of doubly reinforced beam.

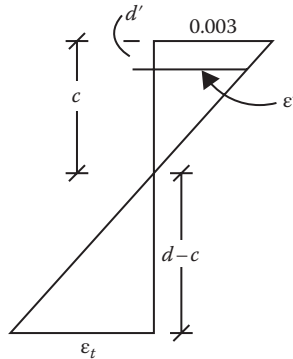


FIGURE 15.2 Strain diagram of concrete.

$$\epsilon_t = \frac{0.003 (d - c)}{c} \tag{15.3}$$

1. When  $\epsilon'_s \geq f_y/E$ , the compression steel has yielded,  $f'_s = f_y$ , and from the forces shown in Figure 15.1c,

$$A_{s2} = A'_s \tag{15.4}$$

2. When  $\epsilon'_s < f_y/E$ , the compression steel has not yielded,  $f'_s = \epsilon'_s E$ , and again from the forces shown in Figure 15.1c,

$$A_{s2} = \frac{A'_s f'_s}{f_y} \tag{15.5}$$

3. When  $\epsilon_t \geq 0.005$ ,  $\phi = 0.9$ .
4. When  $\epsilon_t < 0.005$ , compute  $\phi$  from Equation 14.13.

To ascertain the value of neutral axis,  $c$ , the tensile strength of the beam is equated with the compression strength. Thus, from Figure 15.1

$$\begin{aligned} \text{Tensile force} &= \text{Compression force} \\ A_{s1} f_y + A_{s2} f_y &= 0.85 f'_c ab + A'_s f'_s \\ (A_{s1} + A_{s2}) f_y &= 0.85 f'_c ab + A'_s \epsilon'_s E \end{aligned}$$

Substituting  $a = \beta_1 c$  from Equation 14.3,  $\epsilon'_s$  from Equation 15.2 and  $E = 29000$  ksi

$$A_s f_y = 0.85 f'_c \beta_1 c b + A'_s \frac{(c - d')}{c} (0.003)(29,000) \quad (15.6)$$

where  $\beta_1$  is given in Equation 14.4, and the others terms are explained in Figure 15.1

## ANALYSIS OF DOUBLY REINFORCED BEAMS

A summary of the steps for analysis of a doubly reinforced beam is presented below:

1. From Equation 15.6, determine  $c$ ; and from Equation 14.3, compute  $a$ .
2. From Equation 15.2 compute  $\epsilon'_s$ . If  $\epsilon'_s < f_y / E$ , that is the compression steel has not yielded, use Equation 15.5 to determine  $A_{s2}$ , otherwise use Equation 15.4 to determine  $A_{s2}$ .
3. From Equation 15.3, compute  $\epsilon_t$  and from that determine  $\phi$  as stated in step 3 and 4 of previous section.
4. Compute the moment capacity from Equation 15.1.

### Example 15.1

Determine the moment capacity of the beam shown in Figure 15.3. Use  $f'_c = 3,000$  psi,  $f_y = 60,000$  psi.

## SOLUTION

1. From Equation 15.6

$$A_s f_y = 0.85 f'_c \beta_1 c b + A'_s \frac{(c - d')}{c} (0.003)(29,000)$$

$$6.24(60) = 0.85(3)(0.85)c(14) + 2 \frac{(c - 2.5)}{c} (0.003)(29,000)$$

$$374.4 = 30.345c + \frac{174(c - 2.5)}{c}$$

$$374.4c = 30.345c^2 + 174c - 435$$

$$30.345c^2 - 200.4c - 435 = 0$$

$$c^2 - 6.60c - 14.335 = 0$$

$$c = \frac{+6.60 \pm \sqrt{(6.60)^2 + 4(14.335)}}{2} = 8.32 \text{ in. (positive value)}$$

$$a = \beta_1 c = 0.85(8.32) = 7.07 \text{ in.}$$

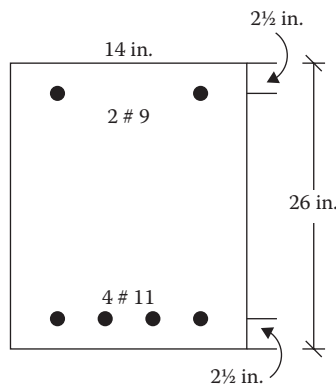


FIGURE 15.3 Beam section of Example 15.1.

2. From Equation 15.2

$$\begin{aligned}\epsilon'_s &= \frac{0.003(c - d')}{c} \\ &= \frac{0.003(8.32 - 2.5)}{8.32} = 0.0021\end{aligned}$$

$$\frac{f_y}{E} = \frac{60}{29,000} = 0.0021$$

Since  $\epsilon'_s = f_y/E$ , the compression steel has yielded.

$$f'_s = f_y = 60 \text{ ksi}$$

$$A_{s2} = A'_s = 2 \text{ in.}^2$$

$$A_{s1} = 6.24 - 2 = 4.24 \text{ in.}^2$$

3. From Equation 15.3

$$\begin{aligned}\epsilon_t &= \frac{0.003(d - c)}{c} \\ &= \frac{0.003(23.5 - 8.32)}{8.32} = 0.0055\end{aligned}$$

Since  $\epsilon_t > 0.005$ ,  $\phi = 0.9$ .

4. Moment capacity, from Equation 15.1

$$\begin{aligned}M_u &= \phi A_{s1} f_y \left( d - \frac{a}{2} \right) + \phi A_{s2} f_y (d - d') \\ &= 0.9(4.24)(60) \left( 23.5 - \frac{7.07}{2} \right) + 0.9(2)(60)(23.5 - 2.5) \\ &= 6839.19 \text{ in.-k or } 569.9 \text{ ft.-k}\end{aligned}$$

### Example 15.2

Determine the moment capacity of the beam shown in Figure 15.4. Use  $f'_c = 4,000$  psi,  $f_y = 60,000$  psi.

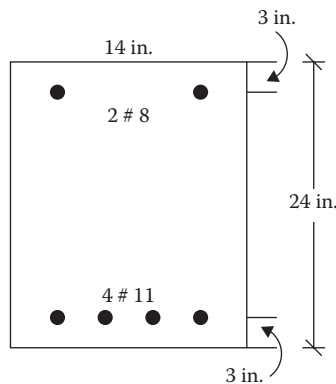


FIGURE 15.4 Beam section of Example 15.2.

**SOLUTION**

1. From Equation 15.6

$$A_s f_y = 0.85 f'_c \beta_1 c b + A'_s \frac{(c - d')}{c} (0.003)(29,000)$$

$$6.24(60) = 0.85(4)(0.85)c(14) + 1.58 \frac{(c - 3)}{c} (0.003)(29,000)$$

$$374.4 = 40.46c + 137.46 \frac{(c - 3)}{c}$$

$$374.4c = 40.46c^2 + 137.46c - 412.38$$

$$40.46c^2 - 236.94c - 412.38 = 0$$

$$c^2 - 5.856c - 10.19 = 0$$

$$c = \frac{+5.856 \pm \sqrt{(5.856)^2 + 4(10.19)}}{2} = 7.26 \text{ in. (positive value)}$$

$$a = \beta_1 c = 0.85(7.26) = 6.17 \text{ in.}$$

2. From Equation 15.2

$$\begin{aligned} \epsilon'_s &= 0.003 \frac{(c - d')}{c} \\ &= \frac{0.003(7.26 - 3)}{7.26} = 0.0018 \end{aligned}$$

$$\frac{f_y}{E} = \frac{60}{29,000} = 0.0021$$

Since  $\epsilon'_s < f_y/E$ , the compression steel has not yielded.

$$f'_s = \epsilon'_s E = 0.0018(29,000) = 52.20 \text{ ksi}$$

From Equation 15.5

$$A_{s2} = \frac{A'_s f'_s}{f_y} = \frac{1.58(52.20)}{60} = 1.375 \text{ in.}^2$$

$$A_{s1} = 6.24 - 1.375 = 4.865 \text{ in.}^2$$

3. From Equation 15.3

$$\begin{aligned} \epsilon_t &= \frac{0.003(d - c)}{c} \\ &= \frac{0.003(24 - 7.26)}{7.26} = 0.0069 \end{aligned}$$

Since  $\epsilon_t > 0.005$ ,  $\phi = 0.9$ .

4. Moment capacity, from Equation 15.1

$$\begin{aligned} M_u &= \phi A_{s1} f_y \left( d - \frac{a}{2} \right) + \phi A_{s2} f'_s (d - d') \\ &= 0.9(4.865)(60) \left( 24 - \frac{6.17}{2} \right) + 0.9(1.375)(60)(24 - 3) \\ &= 7053.9 \text{ in.-k or } 587.8 \text{ ft.-k} \end{aligned}$$

## DESIGN OF DOUBLY REINFORCED BEAMS

A summary of the steps to design a doubly reinforced beam is presented below:

1. Determine the factored moment  $M_u$  due to applied loads.
2. Ascertain  $\rho$  corresponding to  $\epsilon_t = 0.005$  from Appendix D, Table D.11 and  $\bar{K}$  from Appendix D, Tables D.4 through D.10 and also determine  $A_{s1} = \rho bd$ .
3. Compute  $M_{u1} = \phi bd^2 \bar{K}$ , assuming  $\phi = 0.9$ .
4. Compute  $M_{u2} = M_u - M_{u1}$ .
5. Compute (1)  $a = \frac{A_{s1} f_y}{0.85 f'_c b}$  and (2)  $c = a/\beta_1$ .
6. Compute  $\epsilon'_s$  from Equation 15.2.  
When  $\epsilon'_s \geq f_y/E$ , the compression steel has yielded,  $f'_s = f_y$ .  
When  $\epsilon'_s < f_y/E$ , the compression steel has not yielded,  $f'_s = \epsilon'_s E$ .
7. Compute

$$A'_s = \frac{M_{u2}}{\phi f'_s (d - d')}$$

8. Compute

$$A_{s2} = \frac{A'_s f'_s}{f_y}$$

If the amount of compression steel  $A'_s$  and tensile steel  $A_s$  are selected exactly as computed,  $\epsilon_t$  will be 0.005, that is, the tension-controlled condition prevails. However, selecting different amounts of steel may change this condition resulting in a reduced value of  $\phi$  of less than 0.9. Technically, after the amounts of steel are selected, it converts to a problem of analysis as described in the previous section to confirm that the resisting moment capacity is adequate for the applied bending moment.

### Example 15.3

A simply supported beam of span 30 ft. is subjected to a dead load of 2.4 k/ft. and a live load of 3.55 k/ft. From architectural consideration, the beam dimensions are fixed as shown in Figure 15.5. Design the beam. Use  $f'_c = 4,000$  psi and  $f_y = 60,000$  psi.

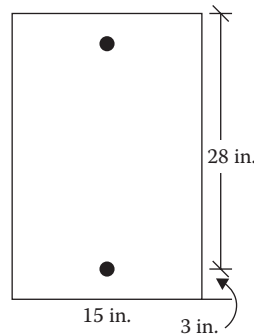


FIGURE 15.5 Size of beam for Example 15.3.

**SOLUTION**

$$1. \text{ Weight of beam/ft.} = \frac{31}{12} \times \frac{15}{12} \times 1 \times 150 = 484 \text{ lb/ft. or } 0.484 \text{ k/ft.}$$

$$w_u = 1.2(2.4 + 0.484) + 1.6(3.55) = 9.141 \text{ k/ft}$$

$$M_u = \frac{wL^2}{8} = \frac{9.41(30)^2}{8} = 1028.4 \text{ ft.-k}$$

2. From Appendix D, Table D.11,  $\rho = 0.0181$ .  
From Appendix D, Table D.9,  $\bar{K} = 0.911 \text{ ksi}$ .

$$A_{s1} = \rho b d = (0.0181)(15)(28) = 7.6 \text{ in.}^2$$

$$3. M_{u1} = \phi b d^2 \bar{K} = (0.9)(15)(28)^2 (0.911) = 9642 \text{ in.-k or } 803.5 \text{ ft.-k}$$

$$4. M_{u2} = M_u - M_{u1} = 1028.4 - 803.5 = 224.9 \text{ ft.-k or } 2698.8 \text{ in.-k}$$

$$5. a = \frac{A_{s1} f_y}{0.85 f'_c b} = \frac{760(60)}{0.85(4)(15)} = 8.94 \text{ in.}$$

$$c = \frac{a}{\beta_1} = \frac{8.94}{0.85} = 10.52 \text{ in.}$$

$$6. \epsilon'_s = 0.003 \frac{(c - d')}{c}$$

$$= \frac{0.003(10.52 - 3)}{10.52} = 0.0021$$

$$\frac{f_y}{E} = \frac{60}{29,000} = 0.0021$$

Since  $\epsilon'_s = f_y/E$ , the compression steel has yielded.  
 $f'_s = f_y = 60 \text{ ksi}$

$$7. A'_s = \frac{M_{u2}}{\phi f'_s (d - d')} = \frac{2698.8}{0.9(60)(28 - 3)} = 2.0 \text{ in.}^2; \text{ Use 2 bars of \#9, } A'_s = 2 \text{ in.}^2$$

$$8. A_{s2} = \frac{A'_s f'_s}{f_y} = \frac{2.0(60)}{60} = 2 \text{ in.}^2$$

$$A_s = 7.6 + 2.0 = 9.6 \text{ in.}^2; \text{ Use 8 bars of \#10, } A_s = 10.2 \text{ in.}^2 \text{ (two layers)}$$

**MONOLITHIC SLAB AND BEAM (T BEAMS)**

The concrete floor systems generally consist of slabs and beams that are monolithically cast together. In such cases the slab acts as a part of the beam, resulting in a T-shaped beam section as shown in Figure 15.6. The slab portion is called a flange and the portion below the slab is called a web. The slab spans from beam to beam. But, the American Concrete Institute (ACI) code defines a limited width that can be considered as a part of the beam. According to ACI this effective flange width should be the smallest of the following three values:\*

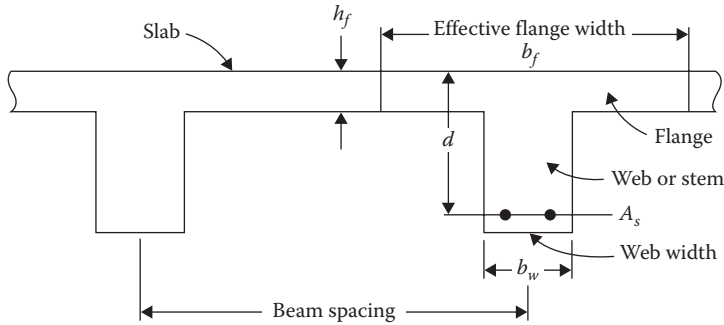
$$1. b_f = \text{one-fourth of the span} \quad (15.7a)$$

$$2. b_f = b_w + 16 h_f \quad (15.7b)$$

$$3. b_f = \text{center to center spacing of beams} \quad (15.7c)$$

A T beam has five relevant dimensions: (1) flange width,  $b_f$ ; (2) flange thickness,  $h_f$ ; (3) width of web or stem,  $b_w$ ; (4) effective depth of beam,  $d$ ; and (5) tensile steel area,  $A_s$ .

\* For an L-shaped beam, the overhang portion of the flange should be the smallest of (1) one-twelfth of the span length; (2) six times the slab thickness,  $h_f$ ; and (3) one-half of the clear distance between beams.



**FIGURE 15.6** T beam comprising slab and supporting beam of a floor system.

In analysis type of problems, all five of these parameters are known and the objective is to determine the design capacity of the beam. In the design of T beams, the flange is designed separately as a slab spanning between the beams (webs) according to the procedure described for one-way slabs in Chapter 14. The effective width of the flange is ascertained according to Equation 15.7. The size of the web is fixed to satisfy the shear capacity or other architectural requirements. Thus the values of  $b_f$ ,  $h_f$ ,  $b_w$ , and  $d$  are preselected and a design consists of computing of the area of tensile steel.

Under a positive bending moment, the concrete on the flange side resists compression and the steel in the web resists tension. Depending on the thickness of the flange, the compression stress block might fully confine within the flange or it might fully cover the flange thickness and further extend into the web. Mostly the former condition exists.

In the first case a T beam acts like a rectangular beam of width  $b_f$  because all the concrete area below the compression stress block is considered to be cracked, and thus any shape of concrete below this compression stress block does not matter.

The minimum steel requirements as specified by Equations 14.11 and 14.12 apply to T beams also.

## ANALYSIS OF T BEAMS

1. Determine the effective flange width,  $b_f$  from Equation 15.7.
2. Check for minimum steel using Equations 14.11 and 14.12 using web width  $b_w$  for beam width.
3. Determine the area of the compression block,  $A_c$ :

$$A_c = \frac{A_s f_y}{0.85 f'_c} \quad (15.8)$$

4. In most cases,  $A_c \leq b_f h_f$ , that is, the compression stress block lies within the flange. In such cases the depth of the stress block is given by

$$a = \frac{A_c}{b_f} \quad (15.9)$$

and the centroid of the compression block from the top is given by

$$\bar{y} = \frac{a}{2} \quad (15.10)$$



5. When  $A_c > b_f h_f$ , the compression stress block extends into the web to an extent  $A_c$  exceeding the flange area  $b_f h_f$ . The centroid is determined for the area of the flange and the area extending into web as demonstrated in Example 15.4.
6. Determine (1)  $c = a/\beta_1$ , where  $\beta_1$  is given in Equation 14.4; (2)  $\epsilon_t = 0.0003(d - c)/c$  and (3)  $Z = d - \bar{y}$ .
7. If  $\epsilon_t < 0.005$ , adjust  $\phi$  by Equation 14.13.
8. Calculate the moment capacity:

$$\phi M_n = \phi A_s f_y Z$$

### Example 15.4

Determine the moment capacity of the T beam spanning 20 ft., as shown in Figure 15.7. Use  $f'_c = 3,000$  psi and  $f_y = 60,000$  psi.

### SOLUTION

1. Effective flange width,  $b_f$ 
  - a.  $\frac{\text{span}}{4} = \frac{20 \times 12}{4} = 60$  in.
  - b.  $b_w + 16h_f = 11 + 16(3) = 59$  in.
  - c. Beam spacing =  $3 \times 12 = 36$  in. ← Controls
2. Minimum steel
  - a.  $\frac{3\sqrt{f'_c} b_w d}{f_y} = \frac{3\sqrt{3,000}(11)(24)}{60,000} = 0.723$  in.<sup>2</sup>
  - b.  $\frac{200b_w d}{f_y} = \frac{200(11)(24)}{60,000} = 0.88$  in.<sup>2</sup> < 6.35 in.<sup>2</sup> **OK**
3. Area of compression block
 
$$A_c = \frac{A_s f_y}{0.85 f'_c} = \frac{(6.35)(60,000)}{(0.85)(3,000)} = 149.41 \text{ in.}^2$$

$$b_f h_f = (36)(3) = 108 \text{ in.}^2$$

Since  $149.41 > 108$ , the stress block extends into web by a distance  $a_1$  below the flange.
4.  $a_1 = \frac{A_c - b_f h_f}{b_w} = \frac{149.41 - 108}{11} = 3.76$  in.<sup>2</sup>

$$a = 3 + 3.76 = 6.76 \text{ in.}$$

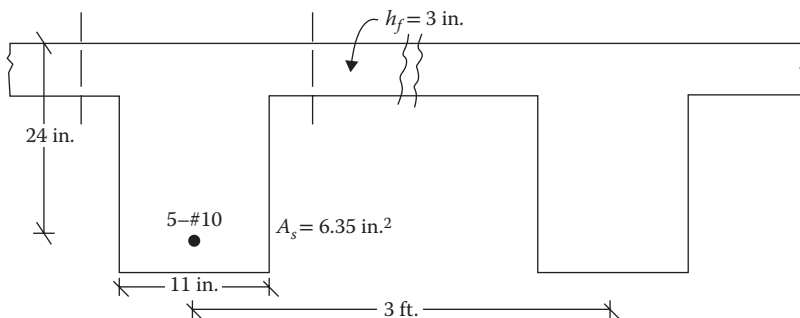


FIGURE 15.7 T beam dimensions for Example 15.4.

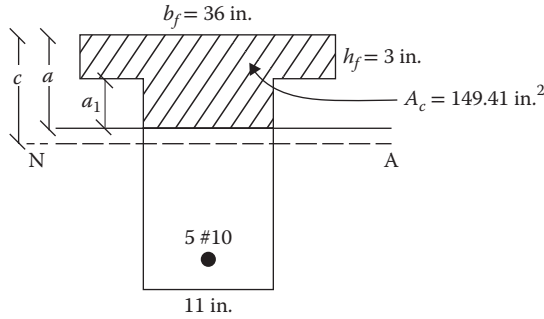


FIGURE 15.8 Compression stress block for Example 15.4.

5. In Figure 15.8, the centroid of the compression block from the top:

$$\bar{y} = \frac{[36 \times 3 \times 1.5] + [11 \times 3.76 \times (3 + 3.76/2)]}{149.41} = 2.435 \text{ in.}$$

6.  $c = \frac{6.76}{0.85} = 7.95 \text{ in.}$

$$\epsilon_t = \frac{0.003(24 - 7.95)}{7.95} = 0.0061 > 0.005, \text{ hence } \phi = 0.9$$

$$Z = d - \bar{y} = 24 - 2.435 = 21.565 \text{ in.}$$

7. Moment capacity

$$\phi M_n = \phi A_s f_y Z = 0.9(6.35)(60)(21.565) = 7394.64 \text{ in.-k or } 616.2 \text{ ft.-k}$$

## DESIGN OF T BEAMS

As stated earlier, design consists of determining only the tensile steel area of a T beam. This process is the reverse of the analysis. The steps are as follows:

1. Compute the factored design moment including the dead load.
2. Determine the effective flange width,  $b_f$ , from Equation 15.7.
3. Adopt the effective depth  $d = h - 3$  when the overall depth  $h$  is given. Assume the moment arm  $Z$  to be the larger of the following:
  - (1)  $0.9d$  or (2)  $(d - h_f/2)$ .
4. Calculate the steel area:

$$A_s = \frac{M_u}{\phi f_y Z}, \text{ for initial value of } \phi = 0.9$$

5. Calculate the area of the compression block,  $A_c$ :

$$A_c = \frac{A_s f_y}{0.85 f'_c} \quad (15.8)$$

6. Determine the depth of the stress block,  $a$ .

In most cases,  $A_c \leq b_f h_f$ , that is, the compression stress block lies within the flange. In such cases the depth of the stress block is given by

$$a = \frac{A_c}{b_f} \quad (15.9)$$

and the centroid of the compression block from the top is given by

$$\bar{y} = \frac{a}{2} \quad (15.10)$$

When  $A_c > b_f h_f$ , the compression stress block extends into web to the extent  $A_c$  exceeding the flange area  $b_f h_f$ . The centroid is determined for the areas in the flange and web as shown in Example 15.4.

7. Determine (1)  $c = a/\beta_1$ , where  $\beta_1$  is given in Equation 14.4; and (2)  $\epsilon_t = \frac{0.003(d-c)}{c}$ .
8. If  $\epsilon_t < 0.05$ , adjust  $\phi$  by Equation 14.13 and recalculate the steel area from step 4.
9. Compute the revised moment arm:

$$Z = d - a$$

If the computed  $Z$  is appreciably different than the assumed  $Z$  of step 3, repeat steps 4 through 6, until the value of  $Z$  stabilizes.

10. Make a selection of steel for the final value of  $A_s$  computed.
11. Check for minimum steel by Equations 14.11 and 14.12 or Appendix D, Table D.11.

### Example 15.5

Design a T beam for the floor system spanning 20 ft., as shown in Figure 15.9. The moments due to dead load (including beam weight) and live load are 200 ft.-k and 400 ft.-k, respectively. Use  $f'_c = 3,000$  psi and  $f_y = 60,000$  psi.

### SOLUTION

1. Factored design moment =  $1.2(200) + 1.6(400) = 960$  ft.-k or 11,520 in.-k.
2. Effective flange width,  $b_f$ 
  - a.  $\frac{\text{span}}{4} = \frac{20 \times 12}{4} = 60$  in. ← Controls
  - b.  $B_w + 16h_f = 15 + 16(3) = 63$  in.
  - c. Beam spacing =  $6 \times 12 = 72$  in.
3. Moment arm
  - $Z = 0.9d = 0.9(24) = 21.6$  in.
  - $Z = d - \frac{h_f}{2} = 24 - \frac{3}{2} = 22.5$  in. ← Controls

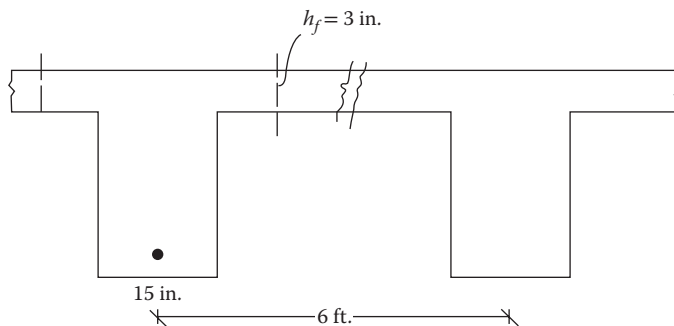


FIGURE 15.9 T beam section for Example 15.5.

4. Steel area

$$A_s = \frac{M_u}{\phi f_y Z} = \frac{11,520}{(0.9)(60)(22.5)} = 9.48 \text{ in.}^2$$

5. Area of compression block

$$A_c = \frac{A_s f_y}{0.85 f'_c} = \frac{(9.48)(60,000)}{(0.85)(3,000)} = 223.06 \text{ in.}^2$$

$$b_f h_f = (60)(3) = 180 \text{ in.}^2$$

Since  $223.06 > 180$ , the stress block extends into the web by a distance  $a_1$  below the flange

$$6. \ a_1 = \frac{A_c - b_f h_f}{b_w} = \frac{223.06 - 180}{15} = 2.87 \text{ in.}^2$$

$$a = 3 + 2.87 = 5.87 \text{ in.}$$

7. In Figure 15.10, the centroid of the compression block from the top

$$\bar{y} = \frac{[60 \times 3 \times 1.5] + [15 \times 2.87 \times (3 + 2.87/2)]}{223.06} = 2.066 \text{ in.}$$

$$8. \ c = \frac{5.87}{0.85} = 6.91 \text{ in.}$$

$$\epsilon_t = \frac{0.003(24 - 6.91)}{6.91} = 0.0074 > 0.005, \text{ hence } \phi = 0.9$$

$$Z = d - \bar{y} = 24 - 2.066 = 21.93 \text{ in.}$$

9. Revised steel area

$$A_s = \frac{M_u}{\phi f_y Z} = \frac{11,520}{(0.9)(60)(21.93)} = 9.73 \text{ in.}^2$$

Select 10 bars of #9,  $A_s = 10 \text{ in.}^2$  in two layers.

The steel area could be refined further by a small margin by repeating steps 5 through 9.

10. Minimum steel

$$1. \ \frac{3\sqrt{f'_c} b_w d}{f_y} = \frac{3\sqrt{3,000}(15)(24)}{60,000} = 0.99 \text{ in.}^2$$

$$2. \ \frac{200 b_w d}{f_y} = \frac{200(15)(24)}{60,000} = 1.20 \text{ in.}^2 < 9.73 \text{ in.}^2 \quad \text{OK}$$

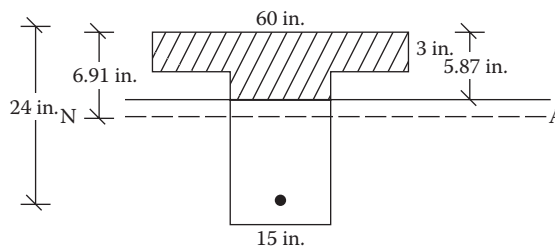
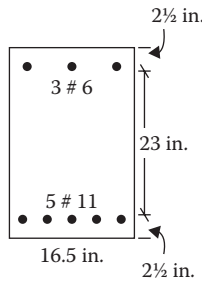


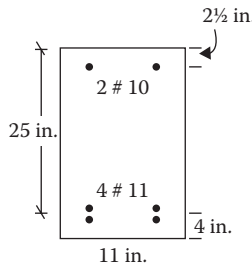
FIGURE 15.10 Compression stress block for Example 15.5.

**PROBLEMS**

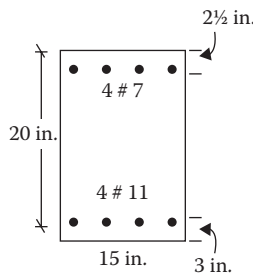
- 15.1 Determine the design strength of the beam shown in Figure P15.1. Use  $f'_c = 4,000$  psi and  $f_y = 60,000$  psi .
- 15.2 Determine the design strength of the beam shown in Figure P15.2. Use  $f'_c = 3,000$  psi and  $f_y = 60,000$  psi .
- 15.3 Determine the design strength of the beam shown in Figure P15.3. Use  $f'_c = 4,000$  psi and  $f_y = 60,000$  psi .
- 15.4 Determine the design strength of the beam shown in Figure P15.4. Use  $f'_c = 5,000$  psi and  $f_y = 60,000$  psi .
- 15.5 A beam of the dimensions shown in Figure P15.5 is subjected to a dead load of 690 lb/ft. and a live load of 1500 lb/ft. It has a simple span of 35 ft. Design the beam. Use  $f'_c = 4,000$  psi and  $f_y = 60,000$  psi.
- 15.6 Design a beam to resist the moment due to service dead load of 150 ft.-k (including weight) and the moment due to service live load of 160 ft.-k. The beam width is limited to 11 in. and the effective depth is limited to 20 in. The compression steel is 3 in. from the top. Use  $f'_c = 3,000$  psi and  $f_y = 60,000$  psi.



**FIGURE P15.1** Beam section for Problem 15.1.



**FIGURE P15.2** Beam section for Problem 15.2.



**FIGURE P15.3** Beam section for Problem 15.3.

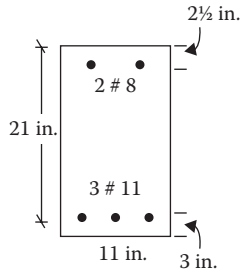


FIGURE P15.4 Beam section for Problem 15.4.

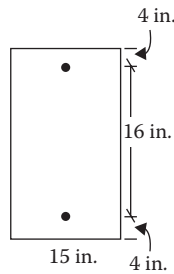


FIGURE P15.5 Beam dimensions for Problem 15.5.

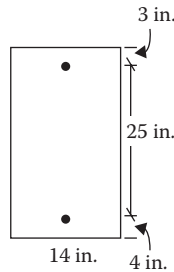


FIGURE P15.6 Beam dimensions for Problem 15.7.

- 15.7** Design a beam to resist the total factored moment (including weight) of 1,000 ft.-k. The dimensions are as shown in Figure P15.6. Use  $f'_c = 4,000$  psi and  $f_y = 50,000$  psi.
- 15.8** Determine the design moment capacity of the T beam shown in Figure P15.7, spanning 25 ft. Use  $f'_c = 4,000$  psi and  $f_y = 60,000$  psi.
- 15.9** Determine the design capacity of the beam in Problem 15.8. The slab thickness is 3 in. and the center to center spacing of beams is 3 ft. Use  $f'_c = 3,000$  psi and  $f_y = 60,000$  psi.
- 15.10** Design a T beam for the floor system shown in Figure P15.8. The live load is 200 psf and the dead load is 60 psf excluding the weight of the beam. The slab thickness is 4 in., the effective depth is 25 in., and the width of the web is 15 in. Use  $f'_c = 3,000$  psi and  $f_y = 60,000$  psi.
- 15.11** Design the T beam shown in Figure P15.9 that spans 25 ft. The moment due to service dead load is 200 ft.-k (including beam weight) and due to service live load is 400 ft.-k. Use  $f'_c = 4,000$  psi and  $f_y = 60,000$  psi.

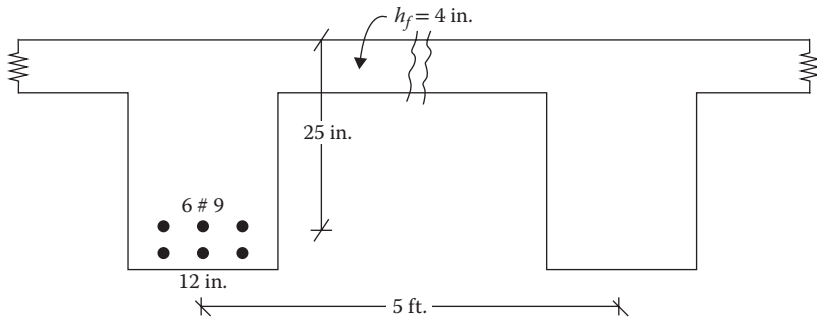


FIGURE P15.7 T beam section for Problem 15.8.

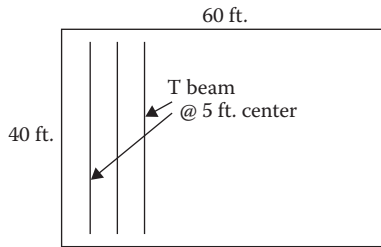


FIGURE P15.8 Floor system for Problem 15.10.

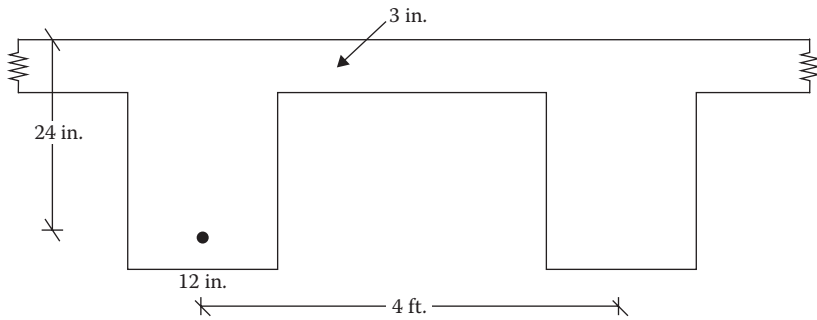


FIGURE P15.9 T beam section for Problem 15.11.





---

# 16 Shear and Torsion in Reinforced Concrete

## STRESS DISTRIBUTION IN BEAM

The transverse loads on a beam segment cause a bending moment and a shear force that vary across the beam cross section and along the beam length. At point (1) in a beam shown in Figure 16.1, these contribute to the bending (flexure) stress and the shear stress, respectively, expressed as follows:

$$f_b = \frac{My}{I} \quad (16.1a)$$

and

$$f_v = \frac{VQ}{Ib} \quad (16.1b)$$

where

$M$  is bending moment at a horizontal distance  $x$  from the support

$y$  is vertical distance of point (1) from the neutral axis

$I$  is moment of inertia of the section

$V$  is shear force at  $x$

$Q$  is moment taken at the neutral axis of the cross-sectional area of the beam above point (1)

$b$  is width of section at (1)

The distribution of these stresses is shown in Figure 16.2. At any point (2) on the neutral axis, the bending stress is zero and the shear stress is maximum (for a rectangular section). On a small element at point (2), the vertical shear stresses act on the two faces balancing each other, as shown in Figure 16.2. According to the laws of mechanics, the complementary shear stresses of equal magnitude and opposite sign act on the horizontal faces as shown, so as not to cause any rotation to the element.

If we consider a free-body diagram along the diagonal a–b, as shown in Figure 16.3, and resolve the forces (shear stress times area) parallel and perpendicular to the plane a–b, the parallel force will cancel and the total perpendicular force acting in tension will be  $1.414f_vA$ . Dividing by the area  $1.41A$  along a–b, the tensile stress acting on plane a–b will be  $f_v$ . Similarly, if we consider a free-body diagram along the diagonal c–d, as shown in Figure 16.4, the total compression stress on the plane c–d will be  $f_v$ . Thus, the planes a–b and c–d are subjected to tensile stress and compression stress, respectively, which has a magnitude equal to the shear stress on the horizontal and vertical faces. These stresses on the planes a–b and c–d are the principal stresses (since they are not accompanied by any shear stress). The concrete is strong in compression but weak in tension. Thus, the stress on plane a–b, known as the *diagonal tension*, is of great significance. It is not the direct shear strength of concrete but the shear-induced diagonal tension that is considered in the analysis and design of concrete beams.

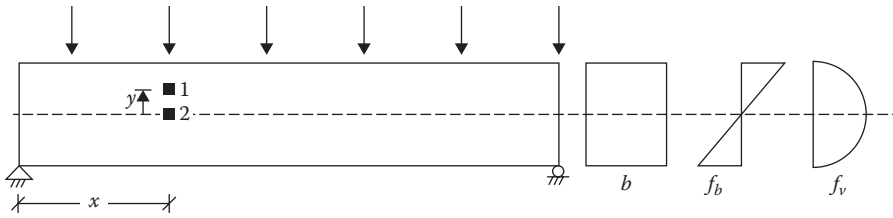


FIGURE 16.1 Flexure and shear stresses on transverse loaded beam.

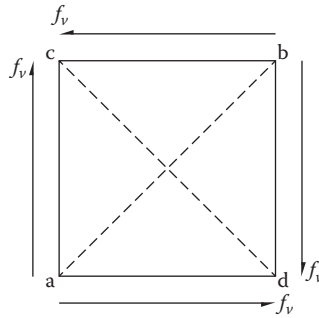


FIGURE 16.2 Shear stresses at neutral axis.

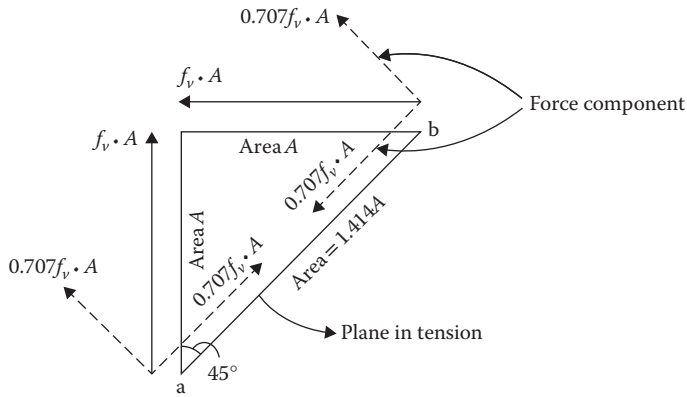


FIGURE 16.3 Free body diagram along plane a–b of element of Figure 16.2.

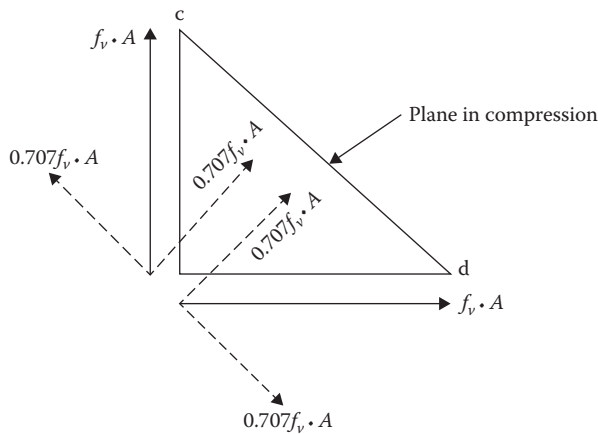


FIGURE 16.4 Free body diagram along plane c–d of element of Figure 16.2.

## DIAGONAL CRACKING OF CONCRETE

There is a tendency for concrete to crack along the plane subjected to tension when the level of stress exceeds a certain value. The cracks will form near the mid-depth where the shear stress (including the diagonal tension) is maximum and will move in a diagonal path to the tensile surface, as shown in Figure 16.5. These are known as the *web-shear cracks*. These are nearer to the support where shear is high. In a region where the moment is higher than the cracking moment capacity, the vertical flexure cracks will appear first and the diagonal shear cracks will develop as an extension to the flexure cracks. Such cracks are known as the *flexure-shear cracks*. These are more frequent in beams. The longitudinal (tensile) reinforcement does not prevent shear cracks but it restrains the cracks from widening up.

After a crack develops, the shear resistance along the cracked plane is provided by the following factors:

1. Shear resistance provided by the uncracked section above the crack,  $V_{cz}$ . This is about 20%–40% of the total shear resistance of the cracked section.
2. Friction developed due to interlocking of the aggregates on opposite sides of the crack,  $V_a$ . This is about 30%–50% of the total.
3. Frictional resistance between concrete and longitudinal (main) reinforcement called the *dowel action*,  $V_d$ . This is about 15%–25% of the total.

In a deep beam, some tie–arch action is achieved by the longitudinal bars acting as a tie and the uncracked concrete above and to the sides of the crack acting as an arch.

Once the applied shear force exceeds the shear resistance offered by the above three factors in a cracked section, the beam will fail suddenly unless a reinforcement known as the *web* or *shear reinforcement* is provided to prevent the further opening up of the crack. It should be understood that the web reinforcement does not prevent the diagonal cracks that will happen at almost the same loads with or without a web reinforcement. It is only after a crack develops that the tension that was previously held by the concrete is transferred to the web reinforcement.

## STRENGTH OF WEB (SHEAR) REINFORCED BEAM

As stated above, the web reinforcement handles the tension that cannot be sustained by a diagonally cracked section. The actual behavior of web reinforcement is not clearly understood in spite of many theories presented. The truss analogy is the classic theory, which is very simple and widely used. The theory assumes that a reinforced concrete beam with web reinforcement behaves like a truss. A concrete beam with vertical web reinforcement in a diagonally cracked section is shown in Figure 16.6. The truss members shown by dotted lines are superimposed in Figure 16.6. The analogy between the beam and the truss members is as shown in Table 16.1.

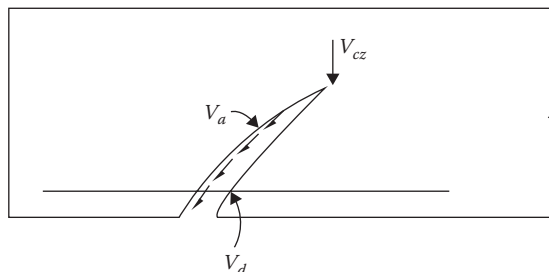


FIGURE 16.5 Shear resistance of cracked concrete.

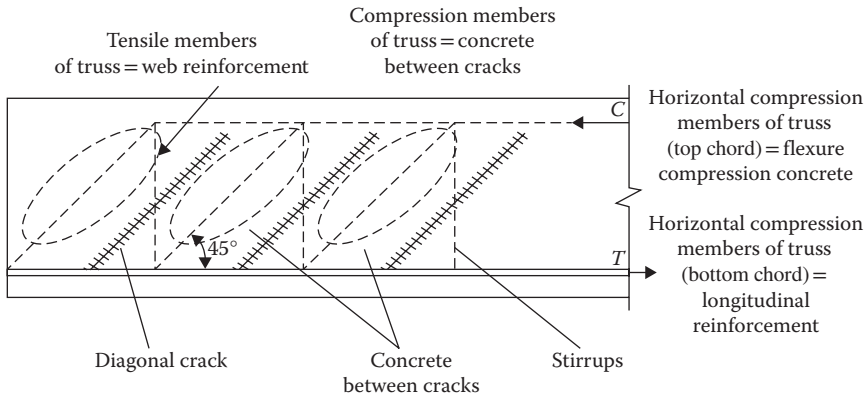


FIGURE 16.6 Truss analogy of beam.

TABLE 16.1  
Beam–Truss Analogy

Truss	Beam
Horizontal tensile member (bottom chord)	Longitudinal reinforcement
Horizontal compression member (top chord)	Flexure compression concrete
Vertical tensile members	Web reinforcement
Diagonal compression members	Web concrete between the cracks in the compression zone

According to the above concept, the web reinforcement represents the tensile member. According to the truss analogy theory, the entire applied shear force that induces the diagonal tension is resisted only by the web reinforcement. But observations have shown that the tensile stress in the web reinforcement is much smaller than the tension produced by the entire shear force. Accordingly, the truss analogy theory was modified to consider that the applied shear force is resisted by two components: the web reinforcement and the cracked concrete section. Thus,

$$V_n = V_c + V_s \tag{16.2}$$

Including a capacity reduction factor,  $\phi$ ,

$$V_u \leq \phi V_n \tag{16.3}$$

For the limiting condition

$$V_u = \phi V_c + \phi V_s \tag{16.4}$$

where

- $V_n$  is nominal shear strength
- $V_u$  is factored design shear force
- $V_c$  is shear contribution of concrete
- $V_s$  is shear contribution of web reinforcement
- $\phi$  is capacity reduction factor for shear = 0.75 (Table 14.1)

Equation 16.4 serves as a design basis for web (shear) reinforcement.

### SHEAR CONTRIBUTION OF CONCRETE

Concrete (with flexure reinforcement but without web reinforcement) does not contribute in resisting the diagonal tension once the diagonal crack is formed. Therefore, the shear stress in concrete at the time of diagonal cracking can be assumed to be the ultimate strength of concrete in shear. Many empirical relations have been suggested for the shear strength. The American Concrete Institute (ACI) has suggested the following relation:

$$V_c = 2\lambda\sqrt{f'_c}bd \tag{16.5}$$

The expression  $\lambda$  was introduced in the ACI 2008 code, to account for lightweight concrete; for normal weight concrete  $\lambda = 1$ . An alternative, much more complicated expression has been proposed by the ACI, which is a function of the longitudinal reinforcement, bending moment, and shear force at various points of beam.

### SHEAR CONTRIBUTION OF WEB REINFORCEMENT

The web reinforcement takes a form of stirrups that run along the face of a beam. The stirrups enclose the longitudinal reinforcement. The common types of stirrups, as shown in Figure 16.7, are U shaped or □ shaped and are arranged vertically or diagonally. When a significant amount of torsion is present, the closed stirrups are used, as shown in Figure 16.7c.

The strength of a stirrup of area  $A_v$  is  $f_y A_v$ . If  $n$  number of stirrups cross a diagonal crack, then the shear strength by stirrups across a diagonal will be

$$V_s = f_y A_v n \tag{16.6}$$

In a 45° diagonal crack, the horizontal length of crack equals the effective depth  $d$ , as shown in Figure 16.8. For stirrups spaced  $s$  on center,  $n = d/s$ . Substituting this in Equation 16.6, we have

$$V_s = f_y A_v \frac{d}{s} \tag{16.7}$$

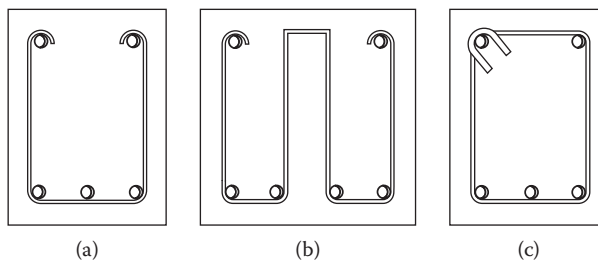


FIGURE 16.7 Types of stirrups: (a) open stirrup, (b) double stirrup, (c) closed stirrup.

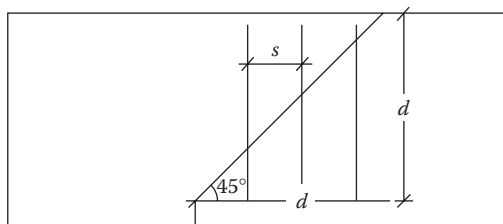


FIGURE 16.8 Vertical stirrup in a diagonal crack.

where

$A_v$  is area of stirrups

$s$  is spacing of stirrups

For a  $\sqcup$  shaped stirrup,  $A_v$  is twice the area of the bar and for a  $\square$  stirrup,  $A_v$  is four times the bar area.

When the stirrups are inclined at  $45^\circ$ , the shear force component along the diagonal will match the stirrups (web reinforcement) strength, or

$$V_s = 1.414 f_y A_v \frac{d}{s} \quad (16.8)$$

Equations 16.7 and 16.8 can be expressed as a single relation:

$$V_s = \alpha f_y A_v \frac{d}{s} \quad (16.9)$$

where  $\alpha = 1$  for the vertical stirrups, and 1.414 for the inclined stirrups.

## SPECIFICATIONS FOR WEB (SHEAR) REINFORCEMENT

The requirements of ACI 318-11 for web reinforcement are summarized below:

1. According to Equation 16.4, when  $V_u \leq \phi V_c$ , no web reinforcement is necessary. However, the ACI code requires that a minimum web reinforcement should be provided when  $V_u$  exceeds  $1/2\phi V_c$ , except for slabs, shallow beams ( $\leq 10$  in.), and footing.
2. *Minimum steel:* When web reinforcement is provided, its amount should fall between the specified lower and upper limits. The reinforcing should not be so low as to make the web reinforcement steel yield as soon as a diagonal crack develops. The minimum web reinforcement area should be the *higher* of the following two values:

$$(A_v)_{min} = \frac{0.75\sqrt{f'_c}bs}{f_y} \quad (16.10)$$

or

$$(A_v)_{min} = \frac{50bs}{f_y} \quad (16.11)$$

3. *Maximum steel:* The maximum limit of web reinforcement is set because the concrete will eventually disintegrate no matter how much steel is added. The upper limit is

$$(A_v)_{max} = \frac{8\sqrt{f'_c}bs}{f_y} \quad (16.12)$$

4. *Stirrup size:* The most common stirrup size is #3 bar. Where the value of shear force is large, #4 bar might be used. The use of larger than #4 size is unusual. For a beam width of  $\leq 24$  in., a single loop stirrup  $\sqcup$  is satisfactory. Up to a width of 48 in. a double loop  $\square$  is satisfactory.

### 5. *Stirrup spacing*

- a. *Minimum spacing*: The vertical stirrups are generally not closer than 4 in. on center.  
 b. *Maximum spacing* when  $V_s \leq 4\sqrt{f'_c}bd$ .

The maximum spacing is the smaller of the following:

- i.  $s_{max} = \frac{d}{2}$
- ii.  $s_{max} = 24$  in.
- iii.  $s_{max} = \frac{A_v f_y}{0.75\sqrt{f'_c}b}$  (based on Equation 16.10)
- iv.  $s_{max} = \frac{A_v f_y}{50b}$  (based on Equation 16.11)

- c. *Maximum spacing* when  $V_s > 4\sqrt{f'_c}bd$

The maximum spacing is the smaller of the following:

- i.  $s_{max} = \frac{d}{4}$
- ii.  $s_{max} = 12$  in.
- iii.  $s_{max} = \frac{A_v f_y}{0.75\sqrt{f'_c}b}$  (based on Equation 16.10)
- iv.  $s_{max} = \frac{A_v f_y}{50b}$  (based on Equation 16.11)

6. *Stirrups pattern*: The size of stirrups is held constant while the spacing of stirrups is varied. Generally the shear force decreases from the support toward the middle of the span indicating that the stirrups spacing can continually increase from the end toward the center. From a practical point of view, the stirrups are placed in groups; each group has the same spacing. Only two to three such groups of the incremental spacing are used within a pattern. The increment of spacing shall be in a multiple of whole inches perhaps in a multiple of 3 in. or 4 in.

7. *Critical section*: For a normal kind of loading where a beam is loaded at the top and there is no concentrated load applied within a distance  $d$  (effective depth) from the support, the section located at a distance  $d$  from the face of the support is called the *critical section*. The shear force at the critical section is taken as the design shear value  $V_u$ , and the shear force from the face of the support to the critical section is assumed to be the same as at the critical section. When the support reaction is in tension at the end region of a beam or the loads are applied at the bottom (to the tension flange), or it is a bracket (cantilevered) section, no design shear force reduction is permitted and the critical section is taken at the face of the support itself.

Some designers place their first stirrup at a distance  $d$  from the face of the support while others place the first stirrup at one-half of the spacing calculated at the end.

## ANALYSIS FOR SHEAR CAPACITY

The process involves the following steps to check for the shear strength of an existing member and to verify the other code requirements:

1. Compute the concrete shear capacity by Equation 16.5.
2. Compute the web reinforcement shear capacity by Equation 16.9.

- Determine the total shear capacity by Equation 16.4. This should be more than the applied factored shear force on the beam.
- Check for the spacing of the stirrups from the “Specifications for Web (Shear) Reinforcement” section, step 5.

### Example 16.1

Determine the factored shear force permitted on a reinforced concrete beam shown in Figure 16.9. Check for the web reinforcement spacing. Use  $f'_c = 4,000$  psi,  $f_y = 60,000$  psi.

### SOLUTION

A. Concrete shear capacity from Equation 16.5

$$\begin{aligned} V_c &= 2\lambda\sqrt{f'_c}bd \\ &= 2(1)\sqrt{4000}(16)(27) = 54644 \text{ lb or } 54.64 \text{ k} \end{aligned}$$

B. Web shear capacity from Equation 16.9

$$A_v = 2(0.11) = 0.22 \text{ in.}^2$$

$$\begin{aligned} V_s &= \alpha f_y A_v \frac{d}{s} \\ &= 1(60,000)(0.22)\left(\frac{27}{12}\right) = 29,700 \text{ lb or } 29.7 \text{ k} \end{aligned}$$

C. Design shear force from Equation 16.4

$$\begin{aligned} V_u &= \phi V_c + \phi V_s \\ &= 0.75(54.64) + 0.75(29.7) = 63.26 \text{ k} \end{aligned}$$

D. Maximum spacing

- $4\sqrt{f'_c}bd/1000 = 4\sqrt{4000}(16)(27)/1000 = 109.3 \text{ k}$
- Since  $V_s$  of 29.7 k < 109.3 k

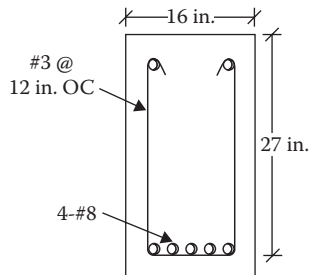


FIGURE 16.9 Section for Example 16.1.



Maximum spacing is smaller of

a.  $\frac{d}{2} = \frac{27}{2} = 13.5 \text{ in.} \leftarrow \text{Controls} > 12 \text{ in. (as given in Example) OK}$

b. 24 in.

c.  $s_{max} = \frac{A_v f_y}{0.75 \sqrt{f'_c} b}$   
 $= \frac{(0.22)(60,000)}{(0.75)\sqrt{4,000}(16)} = 17.4$

d.  $s_{max} = \frac{A_v f_y}{50b}$   
 $= \frac{(0.22)(60,000)}{50(16)} = 16.5 \text{ in.}$

## DESIGN FOR SHEAR CAPACITY

A summary of the steps to design for web reinforcement is presented below:

1. Based on the factored loads and clear span, draw a shear force,  $V_u$ , diagram.
2. Calculate the critical  $V_u$  at a distance  $d$  from the support and show this on the  $V_u$  diagram as the critical section. When the support reaction is in tension, the shear force at the end is the critical  $V_u$ .
3. Calculate  $\phi V_c = (0.75)2\sqrt{f'_c}bd$  and draw a horizontal line at  $\phi V_c$  level on the  $V_u$  diagram. The portion of the  $V_u$  diagram above this line represents  $\phi V_s$ , the portion of the shear force that has to be provided by the web reinforcement or stirrups.
4. Calculate  $1/2\phi V_c$  and show it by a point on the  $V_u$  diagram. The stirrups are needed from the support to this point. Below the  $1/2\phi V_c$  point on the diagram toward the center, no stirrups are needed.
5. Make the tabular computations indicated in steps 5, 6, and 7 for the theoretical stirrups spacing.

Starting at the critical section, divide the span into a number of segments. Determine  $V_u$  at the beginning of each segment from the slope of the  $V_u$  diagram. At each segment, calculate  $V_s$  from the following rearranged Equation 16.4:

$$V_s = \frac{(V_u - \phi V_c)}{\phi}$$

6. Calculate the stirrup spacing for a selected stirrup size at each segment from the following rearranged Equation 16.9:

$$s = \alpha f_y A_v \frac{d}{V_s} \quad (\alpha \text{ being } 1 \text{ for vertical stirrup})$$

7. Compute the maximum stirrup spacing from the equations in the “Specifications for Web (Shear) Reinforcement” section, step 5.

8. Draw a spacing versus distance diagram from step 6. On this diagram, draw a horizontal line at the maximum spacing of step 7 and a vertical line from step 4 for the cut off limit stirrup.
9. From the diagram, select a few groups of different spacing and sketch the design.

**Example 16.2**

The service loads on a reinforced beam are shown in Figure 16.10 along with the designed beam section. Design the web reinforcement. Use  $f'_c = 4,000$  psi and  $f_y = 60,000$  psi.

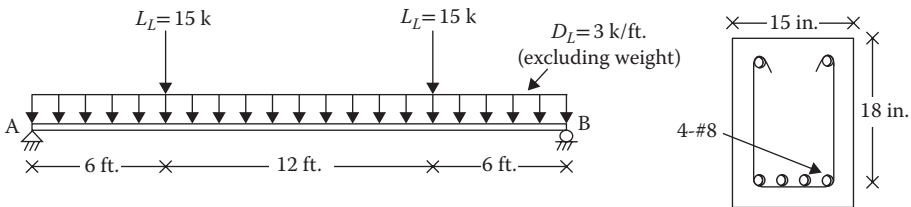
**SOLUTION**

A:  $V_u$  diagram

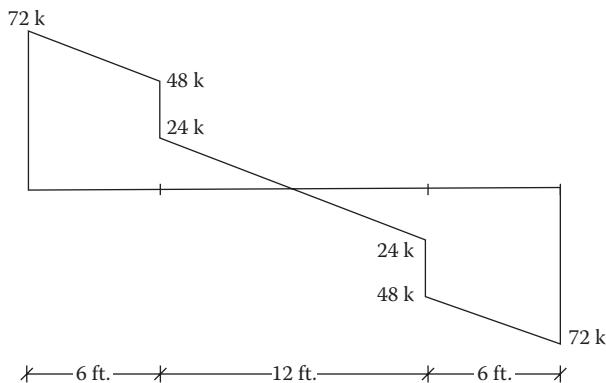
1. Weight of beam =  $(15/12) \times (21/12) \times 1 \times (150/1000) = 0.33$  k/ft.
2.  $w_u = 1.2(3 + 0.33) = 4$  k/ft.
3.  $P_u = 1.6(15) = 24$  k
4.  $M @ B = 0$   
 $R_A(24) - 4(24)(12) - 24(18) - 24(6) = 0$   
 $R_A = 72$  k
5. Shear force diagram is shown in Figure 16.11
6.  $V_u$  diagram for one-half span is shown in Figure 16.12

B. Concrete and steel strengths

1. Critical  $V_u$  at a distance,  $d = 72 - (18/12)(4) = 66$  k
2.  $\phi V_c = 0.75(2)\sqrt{f'_c}bd = 0.75(2)\sqrt{4000}(15)(18)/1000 = 25.61$  k
3.  $1/2\phi V_c = 12.8$  k
4. Distance from the beam center line to  $(1/2)(\phi V_c/\text{slope}) = 12.8/4 = 3.2$  ft.



**FIGURE 16.10** Load on beam and section for Example 16.2.



**FIGURE 16.11** Shear force diagram for Example 16.2.

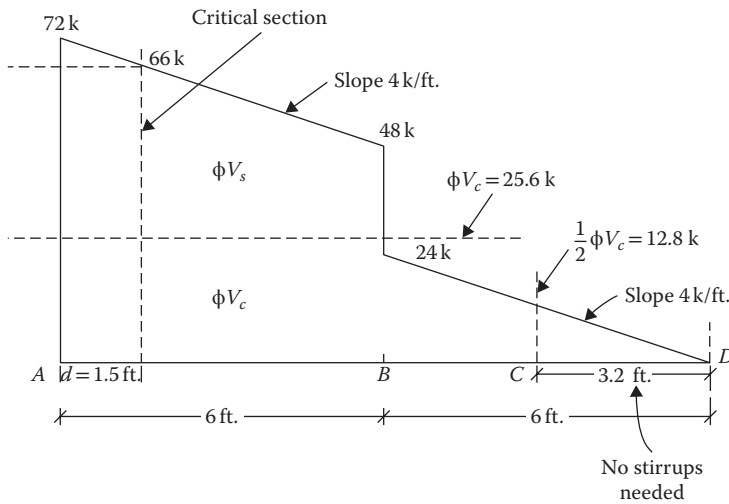


FIGURE 16.12  $V_u$  diagram for Example 16.2.

C. Stirrups design: Use #3 stirrups

Distance from Support, $x$ , ft.	$V_u$ , k	$V_s = \frac{V_u - \phi V_c}{\phi}$ , k	$s = f_y A_v \frac{d}{V_s}$ , in.
1	2	3 <sup>c</sup>	4 <sup>d</sup>
$D = 1.5$	66 <sup>a</sup>	53.87	4.41
2	64	51.20	4.64
4	56	40.53	5.86
6 <sup>-</sup>	48	29.87	7.96
6 <sup>+</sup>	24 <sup>b</sup>	0	$\infty$

<sup>a</sup>  $V_u = V_u@end - (\text{slope})(\text{distance}) = 72 - 4 (\text{Col. 1})$ .  
<sup>b</sup>  $V_u = V_u@B$  in Figure 16.12  $- (\text{slope})(\text{distance} - 6) = 24 - 4 (\text{Col. 1} - 6)$ .  
<sup>c</sup>  $(\text{Col. 2} - 25.61)/0.75$ .  
<sup>d</sup>  $(60,000/1000)(0.22)(18)/\text{Col. 3}$ .

Distance versus spacing from the above table are plotted in Figure 16.13.

D. Maximum spacing

- $4\sqrt{f'_c}bd/1000 = 4\sqrt{4000}(15)(18)/1000 = 68.3$  k
- $V_{s\text{critical}}$  of 53.87 k < 68.3 k
- Maximum spacing is the smaller of

a.  $\frac{d}{2} = \frac{18}{2} = 9$  in. ← Controls

b. 24 in.

c.  $s_{max} = \frac{A_v f_y}{0.75\sqrt{f'_c}b}$   
 $= \frac{(0.22)(60,000)}{(0.75)\sqrt{4,000}(15)} = 18.55$

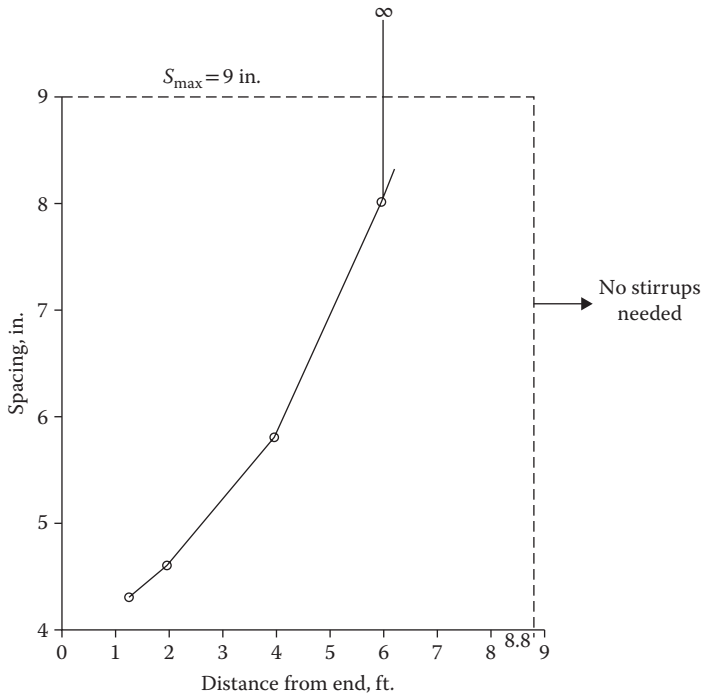


FIGURE 16.13 Distance-spacing graph for Example 16.2.

$$\begin{aligned}
 \text{d. } s_{max} &= \frac{A_v f_y}{50b} \\
 &= \frac{(0.22)(60,000)}{50(15)} = 17.6 \text{ in.}
 \end{aligned}$$

The  $s_{max}$  line is shown in Figure 16.13.

E. Selected spacings

Distance Covered, ft.	Spacing, in.	No. of Stirrups
0-5	4	15
5-6	6	2
6-8.8	9	4

### TORSION IN CONCRETE

Torsion occurs when a member is subjected to a twist about its longitudinal axis due to a load acting off center of the longitudinal axis. Such a situation can be seen in a spandrel girder shown in Figure 16.14.

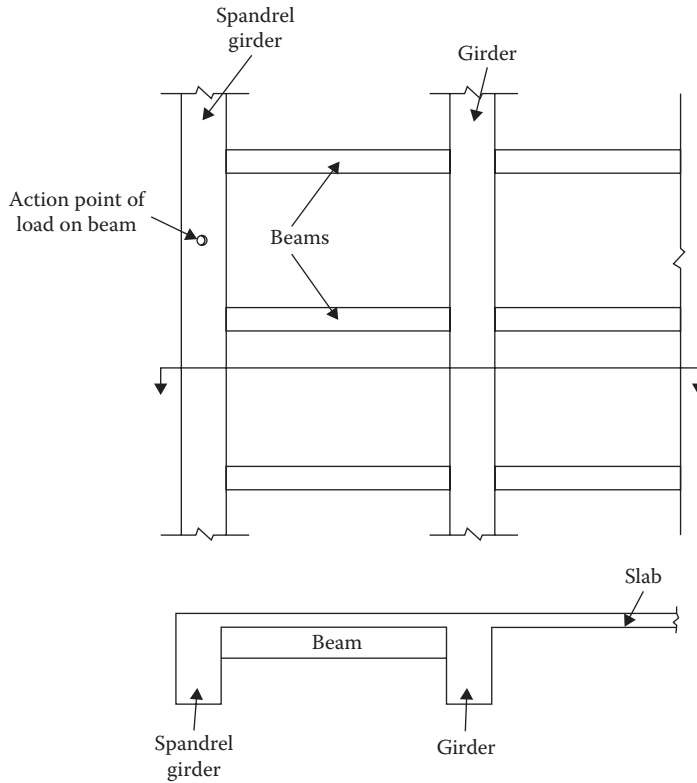
The moment developed at the end of the beam will produce a torsion in the spandrel girder. A similar situation develops when a beam supports a member that overhangs across the beam. An earthquake can cause substantial torsion to the members. The magnitude of torsion can be given by

$$T = Fr \tag{16.13}$$

where

$F$  is force or reaction

$r$  is perpendicular distance of the force from the longitudinal axis



**FIGURE 16.14** Beam subjected to torsion.

A load factor is applied to the torsion to convert  $T$  to  $T_u$  similar to the moment. A torsion produces torsional shear on all faces of a member. The torsional shear leads to diagonal tensile stress very similar to that caused by the flexure shear. The concrete will crack along the spiral lines that will run at  $45^\circ$  from the faces of a member when this diagonal tension exceeds the strength of concrete. After the cracks develop, any additional torsion will make the concrete fail suddenly unless torsional reinforcement is provided. Similar to shear reinforcement, providing torsional reinforcement will not change the magnitude of the torsion at which the cracks will form. However, once the cracks are formed the torsional tension will be taken over by the torsional reinforcement to provide additional strength against the torsional tension.

**PROVISION FOR TORSIONAL REINFORCEMENT**

ACI 318-11 provides that as long as the factored applied torsion,  $T_u$ , is less than one-fourth of the cracking torque  $T_r$ , torsional reinforcement is not required. Equating  $T_u$  to one-fourth of cracking torque  $T_r$ , the threshold limit is expressed as

$$[T_u]_{limit} = \phi \sqrt{f'_c} \frac{A_{cp}^2}{P_{cp}} \tag{16.14}$$

where

$T_u$  is factored design torsion

$A_{cp}$  is area enclosed by the outside parameter of the concrete section = width  $\times$  height

$P_{cp}$  is outside parameter of concrete =  $2(b + h)$

$\phi = 0.75$  for torsion

When  $T_u$  exceeds the above threshold limit, torsional reinforcement has to be designed. The process consists of performing the following computations:

1. Verifying from Equation 16.14 that the cross-sectional dimensions of the member are sufficiently large to support the torsion acting on the beam.
2. If required, designing the closed loop stirrups to support the torsional tension ( $T_u = \phi T_n$ ) as well as the shear-induced tension ( $V_u = \phi V_n$ ).
3. Computing the additional longitudinal reinforcement to resist the horizontal component of the torsional tension. There must be a longitudinal bar in each corner of the stirrups.

When an appreciable torsion is present that exceeds the threshold value, it might be more expedient and economical to select a larger section than would normally be chosen, to satisfy Equation 16.14, so that torsional reinforcement does not have to be provided. The book uses this approach.

### Example 16.3

The concentrated service loads, as shown in Figure 16.15, are located at the end of a balcony cantilever section, 6 in. to one side of the centerline. Is the section adequate without any torsional reinforcement? If not, redesign the section so that no torsional reinforcement has to be provided. Use  $f'_c = 4,000$  psi and  $f_y = 60,000$  psi.

### SOLUTION

The beam is subjected to moment, shear force, and torsion. It is being analyzed for torsion only.

A. Checking the existing section

1. Design load contributing to torsion

$$P_u = 1.2(10) + 1.6(15) = 36 \text{ k}$$

2. Design torsion

$$T_u = 36 \left( \frac{6}{12} \right) = 18 \text{ ft. k}$$

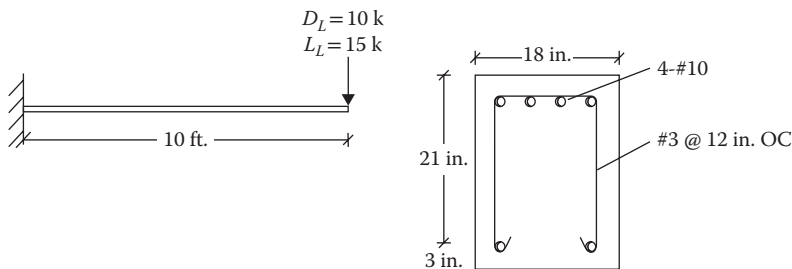


FIGURE 16.15 Cantilever beam and section for Example 16.3.

3. Area enclosed by the outside parameter

$$A_{cp} = bh = 18 \times 24 = 432 \text{ in.}^2$$

4. Outside parameter

$$P_{cp} = 2(b+h) = 2(18+24) = 84 \text{ in.}$$

5. Torsional capacity of concrete

$$\begin{aligned} &= \phi \sqrt{f'_c} \frac{A_{cp}^2}{P_{cp}} \\ &= (0.75) \sqrt{4000} \frac{(432)^2}{84} \\ &= 105,385.2 \text{ in.-lb or } 8.78 \text{ ft.-k} < 18 \text{ k NG} \end{aligned}$$

**B. Redesign the section**

1. Assume a width of 24 in.  
 2. Area enclosed by the outside parameter  $A_{cp} = (24h)$   
 3. Parameter enclosed  $P_{cp} = 2(24 + h)$

4. Torsional capacity  $= \phi \sqrt{f'_c} \frac{A_{cp}^2}{P_{cp}}$

$$\begin{aligned} &= (0.75) \sqrt{4000} \frac{(24h)^2}{2(24+h)} \\ &= 13,661 \frac{h^2}{(24+h)} \text{ in.-lb or } 1.138 \frac{h^2}{(24+h)} \text{ ft.-k} \end{aligned}$$

5. For no torsional reinforcement

$$T_u = \phi \sqrt{f'_c} \frac{A_{cp}^2}{P_{cp}}$$

or

$$18 = 1.138 \frac{h^2}{(24+h)}$$

or

$$h = 29 \text{ in.}$$

A section  $24 \times 29$  will be adequate.

## PROBLEMS

- 16.1–16.3** Determine the concrete shear capacity, web reinforcement shear capacity, and design shear force permitted on the beam sections shown in Figures P16.1 through P16.3. Check for the spacing of web reinforcement. Use  $f'_c = 3,000$  psi and  $f_y = 40,000$  psi.
- 16.4** A reinforced beam of span 20 ft. shown in Figure P16.4 is subjected to a dead load of 1 k/ft. (excluding beam weight) and live load of 2 k/ft. Is the beam satisfactory to resist the maximum shear force? Use  $f'_c = 3,000$  psi and  $f_y = 60,000$  psi.
- 16.5** The service dead load (excluding the beam) is one-half of the service live load on the beam of span 25 ft. shown in Figure P16.5. What is the magnitude of these loads from shear consideration? Use  $f'_c = 4,000$  psi and  $f_y = 60,000$  psi.

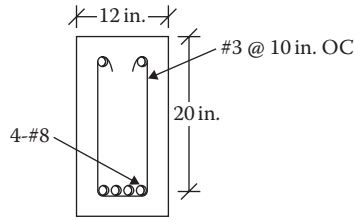


FIGURE P16.1 Beam section for Problem 16.1.

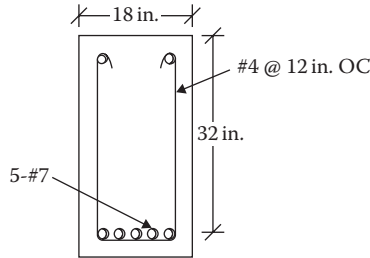


FIGURE P16.2 Beam section for Problem 16.2.

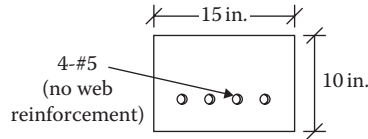


FIGURE P16.3 Beam section for Problem 16.3.

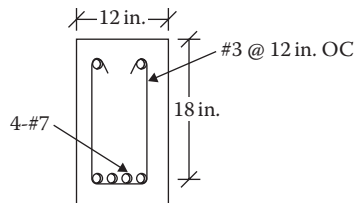


FIGURE P16.4 Beam section for Problem 16.4.

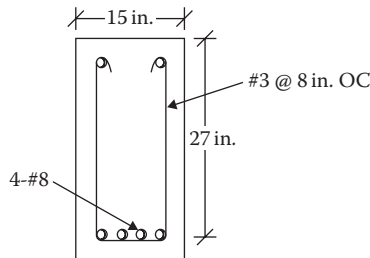


FIGURE P16.5 Beam section for Problem 16.5.

- 16.6** A simply supported beam is 15 in. wide and has an effective depth of 24 in. It supports a total factored load of 10 k/ft. (including the beam weight) on a clear span of 22 ft. Design the web reinforcement. Use  $f'_c = 4,000$  psi and  $f_y = 60,000$  psi.
- 16.7** Design the web reinforcement for the service loads shown in Figure P16.6. Use  $f'_c = 4,000$  psi and  $f_y = 60,000$  psi.



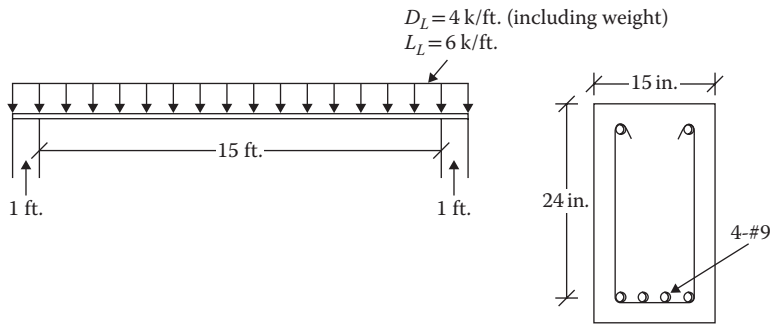


FIGURE P16.6 Loads on beam and section for Problem 16.7.

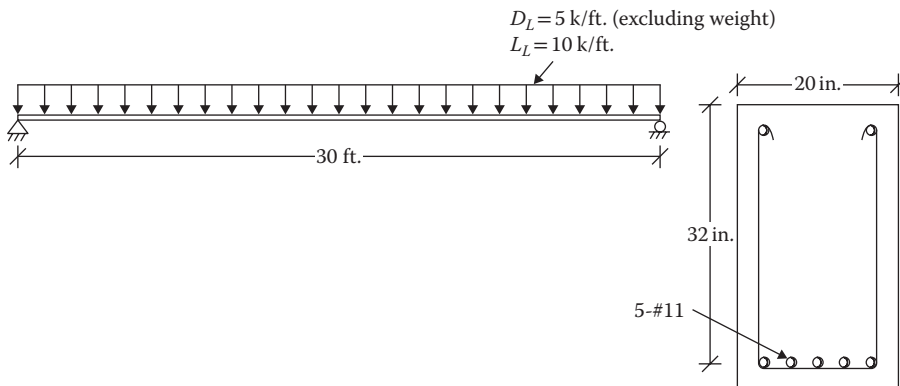


FIGURE P16.7 Loads on beam and section for Problem 16.8.

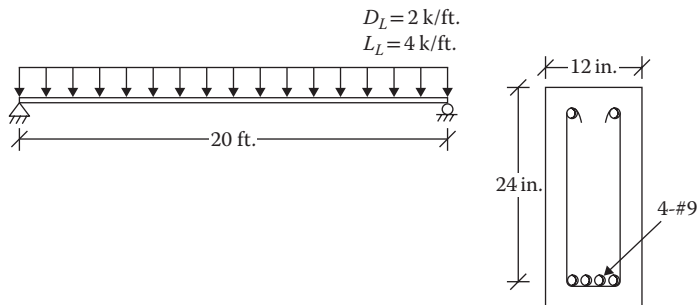


FIGURE P16.8 Loads on beam and section for Problem 16.9.

- 16.8 For the beam and service loads shown in Figure P16.7, design the web reinforcement using #4 stirrups. Use  $f'_c = 5,000$  psi and  $f_y = 60,000$  psi.
- 16.9 For the service loads on a beam (excluding beam weight) shown in Figure P16.8, design the web reinforcement. Use  $f'_c = 4,000$  psi and  $f_y = 50,000$  psi.
- 16.10 Design the web reinforcement for the service loads on the beam shown in Figure P16.9. Use  $f'_c = 3,000$  psi and  $f_y = 40,000$  psi.
- 16.11 A simply supported beam carries the service loads (excluding the beam weight) shown in Figure P16.10. Design the web reinforcement. Use  $f'_c = 4,000$  psi and  $f_y = 60,000$  psi.
- 16.12 A simply supported beam carries the service loads (excluding the beam weight) shown in Figure P16.11. Design the web reinforcement. Use #4 size stirrups. Use  $f'_c = 4,000$  psi and  $f_y = 60,000$  psi.

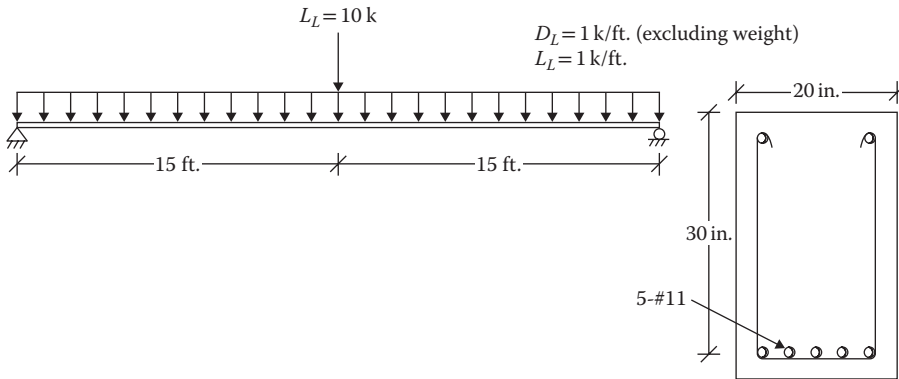


FIGURE P16.9 Loads on beam and section for Problem 16.10.

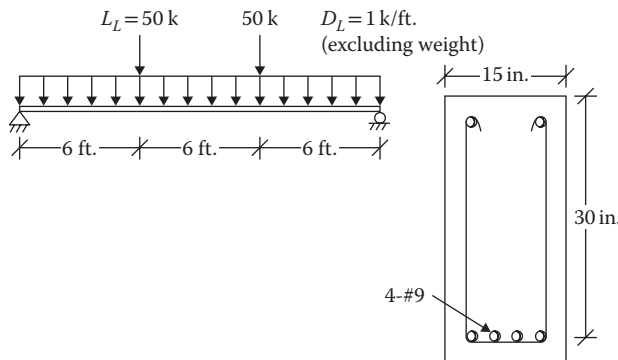


FIGURE P16.10 Loads on beam and section for Problem 16.11.

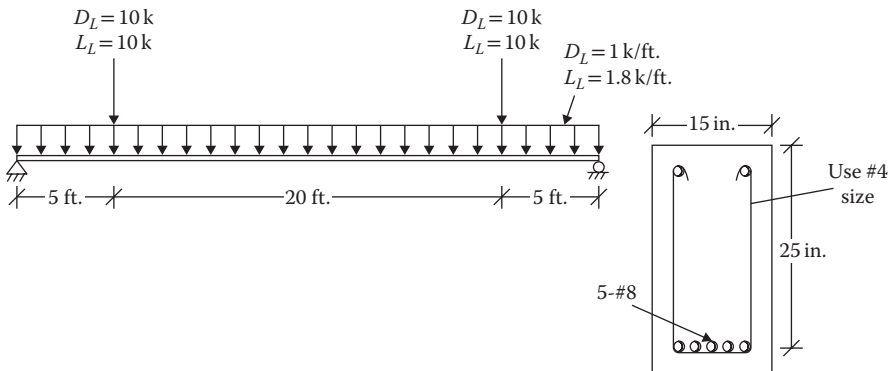


FIGURE P16.11 Loads on beam and section for Problem 16.12.

- 16.13 A cantilever beam carries the service loads, including the beam weight, shown in Figure P16.12. Design the web reinforcement. Use  $f'_c = 4,000$  psi and  $f_y = 60,000$  psi. [Hint:  $V_{critical}$  is at the support.]
- 16.14 A beam carries the factored loads (including beam weight) shown in Figure P16.13. Design the #3 size web reinforcement. Use  $f'_c = 3,000$  psi and  $f_y = 40,000$  psi.
- 16.15 A beam supported on the walls carries the uniform distributed loads and the concentrated loads from the upper floor shown in Figure P16.14. The loads are service loads

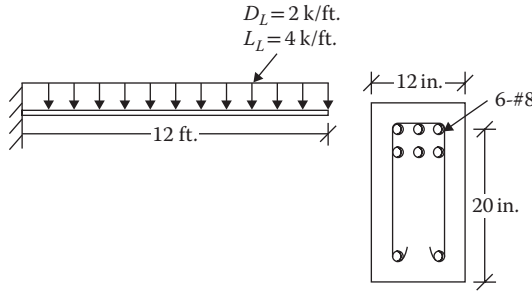


FIGURE P16.12 Loads on cantilever beam and section for Problem 16.13.

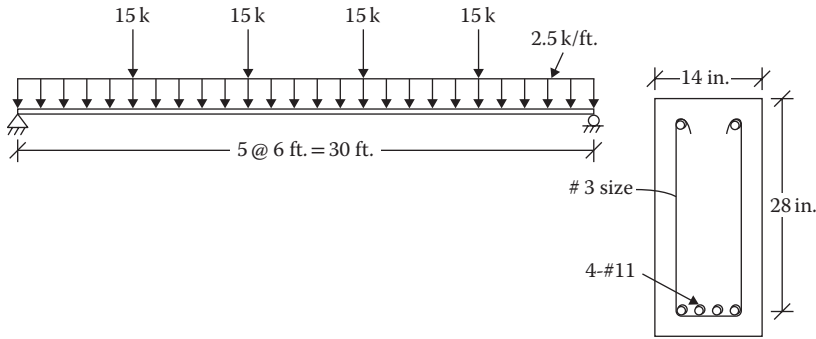


FIGURE P16.13 Loads on beam and section for Problem 16.14.

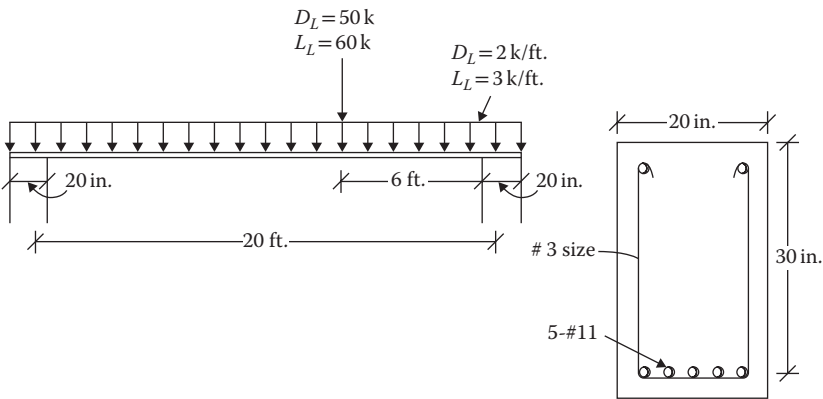


FIGURE P16.14 Loads and section of beam.

including the weight of the beam. Design the #3 size web reinforcement. Use  $f'_c = 4,000$  psi and  $f_y = 50,000$  psi.

**16.16** Determine the torsional capacity of the beam section in Figure P16.15 without torsional reinforcement. Use  $f'_c = 4,000$  psi and  $f_y = 60,000$  psi.

**16.17** Determine the torsional capacity of the cantilever beam section shown in Figure P16.16 without torsional reinforcement. Use  $f'_c = 3,000$  psi and  $f_y = 40,000$  psi.

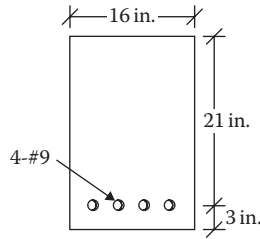


FIGURE P16.15 Beam section under torsion for Problem 16.16.

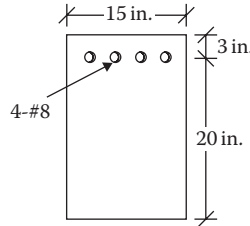


FIGURE P16.16 Cantilever section under torsion for Problem 16.17.

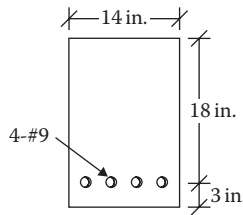


FIGURE P16.17 Beam section under torsion for Problem 16.18.

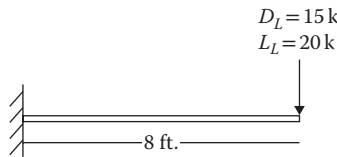


FIGURE P16.18 Torsional loads on cantilever for Problem 16.19.

- 16.18 A spandrel beam shown in Figure P16.17 is subjected to a factored torsion of 8 ft.-k. Is this beam adequate if no torsional reinforcement is used? If not, redesign the section. The width cannot exceed 16 in. Use  $f'_c = 4,000$  psi and  $f_y = 50,000$  psi.
- 16.19 Determine the total depth of a 24 in. wide beam if no torsional reinforcement is used. The service loads, as shown in Figure P16.18, act 5 in. to one side of the centerline. Use  $f'_c = 4,000$  psi and  $f_y = 60,000$  psi.
- 16.20 A spandrel beam is exposed to a service dead load of 8 k and live load of 14 k acting 8 in. off center of the beam. The beam section is 20 in. wide and 25 in. deep. Is the section adequate without torsional reinforcement? If not, redesign the section using the same width. Use  $f'_c = 5,000$  psi and  $f_y = 60,000$  psi.

---

# 17 Compression and Combined Forces Reinforced Concrete Members

## TYPES OF COLUMNS

Concrete columns are divided into four categories.

### PEDESTALS

The column height is less than three times the least lateral dimension. A pedestal is designed with plain concrete (without reinforcement) for a maximum compression strength of  $0.85 \phi f'_c A_g$ , where  $\phi$  is 0.65 and  $A_g$  is the cross-sectional area of the column.

### COLUMNS WITH AXIAL LOADS

The compressive load acts coinciding with the longitudinal axis of the column or at a small eccentricity so that there is no induced moment or there is a moment of little significance. This is a basic case although not quite common in practice.

### SHORT COLUMNS WITH COMBINED LOADS

The columns are subjected to an axial force and a bending moment. However, the buckling effect is not present and the failure is initiated by crushing of the material.

### LARGE OR SLENDER COLUMNS WITH COMBINED LOADS

In this case the buckling effect is present. Due to an axial load,  $P$ , the column axis buckles by an amount  $\Delta$ . Thus, the column is subjected to the secondary moment or the  $P-\Delta$  moment.

As concrete and steel both can share compression loads, steel bars directly add to the strength of a concrete column. The compression strain is equally distributed between concrete and steel that are bonded together. It causes a lengthwise shortening and a lateral expansion of the column due to Poisson's effect. The column capacity can be enhanced by providing a lateral restraint. The column is known as a *tied* or a *spiral* column depending on whether the lateral restraint is in the form of the closely spaced ties or the helical spirals wrapped around the longitudinal bars, as shown in Figure 17.1a and b.

Tied columns are ordinarily square or rectangular and spiral columns are round but they could be otherwise too. The spiral columns are more effective in terms of the column strength because of their hoop stress capacity. But they are more expensive. As such tied columns are more common and spiral columns are used only for heavy loads.

The *composite columns* are reinforced by steel shapes that are contained within the concrete sections or by concrete being filled in within the steel section or tubing as shown in Figure 17.1c and d. The latter are commonly called the *lally* columns.

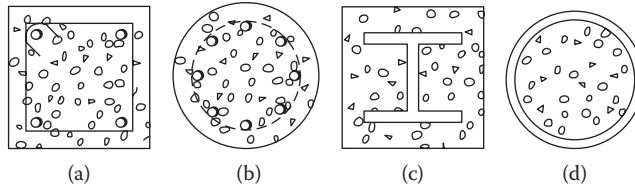


FIGURE 17.1 Types of columns: (a) tied column, (b) spiral column, and (c) and (d) composite columns.

**AXIALLY LOADED COLUMNS**

This category includes columns with a small eccentricity. The small eccentricity is defined when the compression load acts at a distance,  $e$ , from the longitudinal axis controlled by the following conditions:

$$\text{For spiral columns: } e \leq 0.05h \tag{17.1}$$

$$\text{For tied columns: } e \leq 0.1h \tag{17.2}$$

where  $h$  is column dimension along distance,  $e$ .

In the case of columns, unlike beams, it does not matter whether the concrete or steel reaches ultimate strength first because both of them deform/strain together, which distributes the matching stresses between them.

Also, high strength is more effective in columns because the entire concrete area contributes to the strength, unlike the contribution from concrete in the compression zone only in beams, which is about 30%–40% of the total area.

The basis of design is the same as for wood or steel columns, that is,

$$P_u \leq \phi P_n \tag{17.3}$$

where

- $P_u$  is factored axial load on the column
- $P_n$  is nominal axial strength
- $\phi$  = strength reduction factor
  - = 0.70 for spiral column
  - = 0.65 for tied column

The nominal strength is the sum of the strength of concrete and the strength of steel. The concrete strength is the ultimate (uniform) stress  $0.85f'_c$  times the concrete area ( $A_g - A_{st}$ ) and the steel strength is the yield stress,  $f_y$ , times the steel area,  $A_{st}$ . However, to account for the small eccentricity, a factor (0.85 for spiral and 0.8 for tied) is applied.

Thus,

$$P_n = 0.85[0.85f'_c(A_g - A_{st}) + f_y A_{st}] \text{ for spiral columns} \tag{17.4}$$

$$P_n = 0.80[0.85f'_c(A_g - A_{st}) + f_y A_{st}] \text{ for tied columns} \tag{17.5}$$

Including a strength reduction factor of 0.7 for spiral and 0.65 for tied columns in the previous equations, Equation 17.3 for column design is as follows:

For spiral columns with  $e \leq 0.05h$

$$P_u = 0.60[0.85f'_c(A_g - A_{st}) + f_y A_{st}] \tag{17.6}$$

For tied columns with  $e \leq 0.1 h$

$$P_u = 0.52[0.85f'_c(A_g - A_{st}) + f_y A_{st}] \tag{17.7}$$

**STRENGTH OF SPIRALS**

It could be noticed that a higher factor is used for spiral columns than tied columns. The reason is that in a tied column, as soon as the shell of a column spalls off, the longitudinal bars will buckle immediately with the lateral support gone. But a spiral column will continue to stand and resist more load with the spiral and longitudinal bars forming a cage to confine the concrete.

Because the utility of a column is lost once its shell spalls off, the American Concrete Institute (ACI) assigns only slightly more strength to the spiral as compared to strength of the shell that gets spalled off.

With reference to Figure 17.2,

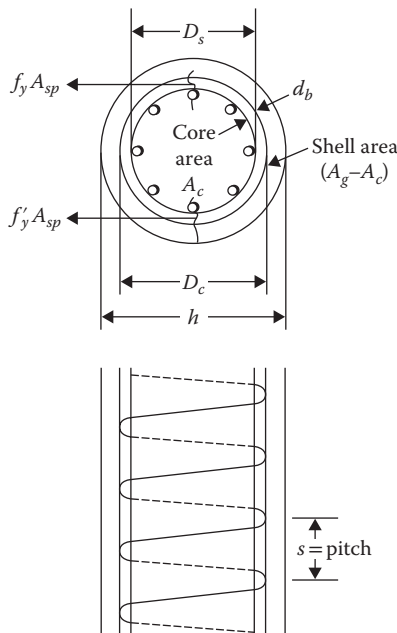
$$\text{Strength of shell} = 0.85f'_c(A_g - A_c) \tag{a}$$

$$\text{Hoop tension in spiral} = 2f_y A_{sp} = 2f_y \rho_s A_c \tag{b}$$

where  $\rho_s$  is spiral steel ratio =  $A_{sp}/A_c$ .

Equating the two expressions (a) and (b) and solving for  $\rho_s$ ,

$$\rho_s = 0.425 \frac{f'_c}{f_y} \left( \frac{A_g}{A_c} - 1 \right) \tag{c}$$



**FIGURE 17.2** Spiral column section and profile.

Making the spiral a little stronger,

$$\rho_s = 0.45 \frac{f'_c}{f_y} \left( \frac{A_g}{A_c} - 1 \right) \quad (17.8)$$

Once the spiral steel is determined, the following expression derived from the definition of  $\rho_s$  is used to set the spacing or pitch of the spiral.

By definition, from Figure 17.2,

$$\rho_s = \frac{\text{volume of spiral in one loop}}{\text{volume of concrete in pitch, } s} \quad (d)$$

$$= \frac{\pi(D_c - d_b)A_{sp}}{(\pi D_c^2/4)s} \quad (e)$$

If the diameter difference, that is,  $d_b$ , is neglected,

$$\rho_s = \frac{4A_{sp}}{D_c s} \quad (f)$$

or

$$s = \frac{4A_{sp}}{D_c \rho_s} \quad (17.9)$$

Appendix D, Table D.13, based on Equations 17.8 and 17.9, can be used to select the size and pitch of spirals for a given diameter of a column.

## SPECIFICATIONS FOR COLUMNS

1. *Main steel ratio*: The steel ratio,  $\rho_g$ , should not be less than 0.01 (1%) and not more than 0.08. Usually a ratio of 0.03 is adopted.
2. *Minimum number of bars*: A minimum of four bars are used within the rectangular or circular ties and six within the spirals.
3. *Cover*: A minimum cover over the ties or spiral shall be  $1\frac{1}{2}$  in.
4. *Spacing*: The clear distance between the longitudinal bars should neither be less than 1.5 times the bar diameter nor  $1\frac{1}{2}$  in. To meet these requirements, Appendix D, Table D.14 can be used to determine the maximum number of bars that can be accommodated in one row within a given size of a column.
5. *Tie requirements*:
  - a. The minimum size of the tie bars is #3 when the size of longitudinal bars is #10 or smaller or when the column diameter is 18 in. or less. The minimum size is #4 for longitudinal bars larger than #10 or a column larger than 18 in. Usually, #5 is the maximum size.
  - b. The center-to-center spacing of ties should be the smaller of the following:
    - i. 16 times the diameter of longitudinal bars
    - ii. 48 times the diameter of ties
    - iii. Least column dimension
  - c. The ties shall be so arranged that every corner and alternate longitudinal bar will have the lateral support provided by the corner of a tie having an included angle of not more than  $135^\circ$ . Figure 17.3 shows the tie arrangements for several columns.



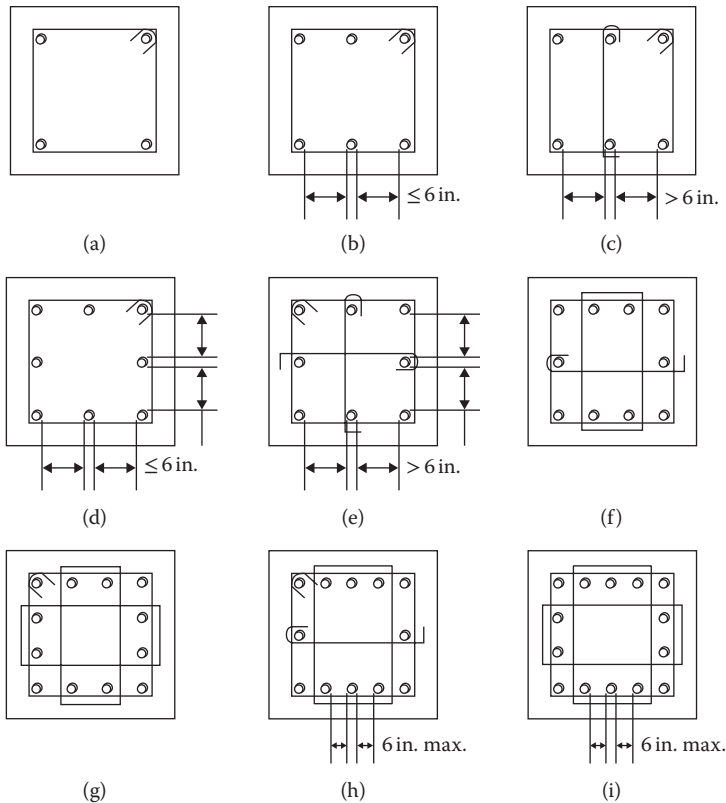


FIGURE 17.3 Tie arrangements for several columns (a) through (i).

- d. Longitudinal bar shall not have more than 6 in. clear distance on either side of a tie. If it is more than 6 in., a tie is provided as shown in Figure 17.3c and e.
6. *Spiral requirements:*
- a. The minimum spiral size is 3/8 in. (#3). Usually the maximum size is 5/8 in. (#5).
  - b. The clear space between spirals should not be less than 1 in. or more than 3 in.

### ANALYSIS OF AXIALLY LOADED COLUMNS

The analysis of columns of small eccentricity involves determining the maximum design load capacity and verifying the amount and details of the reinforcement according to the code. The procedure is summarized below:

1. Check that the column meets the eccentricity requirement ( $\leq 0.05h$  for spiral and  $\leq 0.1h$  for tied column).
2. Check that the steel ratio,  $\rho_g$ , is within 0.01–0.08.
3. Check that there are at least four bars for a tied column and six bars for a spiral column and that the clear spacing between bars is determined according to the “Specifications for Columns” section.
4. Calculate the design column capacity using Equation 17.6 or 17.7.
5. For ties, check the size, spacing, and arrangement using the information in the “Specifications for Columns” section. For spirals, check the size and spacing using the information in the “Specifications for Columns” section.

**Example 17.1**

Determine the design axial load on a 16 in. square axially loaded column reinforced with eight #8 size bars. Ties are #3 at 12 in. on center. Use  $f'_c = 4,000$  psi and  $f_y = 60,000$  psi.

**SOLUTION**

1.  $A_{st} = 6.32$  in.<sup>2</sup> (from Appendix D, Table D.2)
2.  $A_g = 16 \times 16 = 256$  in.<sup>2</sup>
3.  $\rho_g = \frac{A_{st}}{A_g} = \frac{6.32}{256} = 0.0247$   
This is  $>0.01$  and  $<0.08$  **OK**
4.  $h = 2(\text{cover}) + 2(\text{tie diameter}) + 3(\text{bar diameter}) + 2(\text{spacing})$   
or  $16 = 2(1.5) + 2(0.375) + 3(1) + 2(s)$   
or  $s = 4.625$  in.  
 $s_{min} = 1.5(1) = 1.5$  in., spacing  $s$  is more than  $s_{min}$  **OK**  
 $s_{max} = 6$  in., spacing  $s$  is less than  $s_{max}$  **OK**
5. From Equation 17.7

$$P_u = \frac{0.52[0.85(4,000)(256 - 6.32) + (60,000)(6.32)]}{1,000}$$

$$= 638.6 \text{ k}$$

6. Check the ties
  - a. #3 size **OK**
  - b. The spacing should be the smaller of the following:
    - i.  $16 \times 1 = 16$  in. ← Controls, more than given 12 in. **OK**
    - ii.  $48 \times 0.375 = 18$  in.
    - iii. 16 in.
  - c. Clear distance from the tie = 4.625 in. (step 4)  $< 6$  in. **OK**

**Example 17.2**

A service dead load of 150 k and live load of 220 k is axially applied on a 15 in. diameter circular spiral column reinforced with six #9 bars. The lateral reinforcement consists of 3/8 in. spiral at 2 in. on center. Is the column adequate? Use  $f'_c = 4,000$  psi and  $f_y = 60,000$  psi.

**SOLUTION**

1.  $A_{st} = 6$  in.<sup>2</sup> (from Appendix D, Table D.2)
2.  $A_g = \frac{\pi}{4}(15)^2 = 176.63$  in.<sup>2</sup>
3.  $\rho_g = \frac{A_{st}}{A_g} = \frac{6}{176.63} = 0.034$   
This is  $>0.01$  and  $<0.08$ : **OK**
4.  $(D_c - d_b) = h - 2(\text{cover}) - 2(\text{spiral diameter})$   
 $= 15 - 2(1.5) - 2(0.375) = 11.25$  in.
5. Perimeter,  $p = \pi(D_c - d_b) = \pi(11.25) = 35.33$  in.  
 $p = 6(\text{bar diameter}) + 6(\text{spacing})$   
or  $35.33 = 6(1.128) + 6(s)$   
or  $s = 4.76$  in.  
 $s_{min} = 1.5(1) = 1.5$  in., spacing  $s$  is more than  $s_{min}$  **OK**  
 $s_{max} = 6$  in., spacing  $s$  is less than  $s_{max}$  **OK**
6.  $\phi P_n = \frac{0.60[0.85(4,000)(176.63 - 6) + (60,000)(6)]}{1,000} = 564 \text{ k}$

$$7. P_u = 1.2(150) + 1.6(220) = 532 \text{ k} < 564 \text{ k} \text{ OK}$$

8. Check for spiral

a. 3/8 in. diameter **OK**

$$D_c = 15 - 3 = 12 \text{ in.}$$

$$b. A_c = \frac{\pi}{4}(12)^2 = 113.04 \text{ in.}^2$$

$$A_{sp} = 0.11 \text{ in.}^2$$

From Equation 17.8

$$\rho_s = 0.45 \frac{(4)}{(60)} \left( \frac{176.63}{113.04} - 1 \right) = 0.017$$

From Equation 17.9

$$s = \frac{4(0.11)}{(12)(0.017)} = 2.16 \text{ in.} > 2 \text{ in. (given) OK}$$

c. Clear distance =  $2 - 3/8 = 1.625 \text{ in.} > 1 \text{ in. OK}$

## DESIGN OF AXIALLY LOADED COLUMNS

Design involves fixing of the column dimensions, selecting reinforcement, and deciding the size and spacing of ties and spirals. For a direct application, Equations 17.6 and 17.7 are rearranged as follows by substituting  $A_{st} = \rho_g A_g$ .

For spiral columns:

$$P_u = 0.60 A_g [0.85 f'_c (1 - \rho_g) + f_y \rho_g] \quad (17.10)$$

For tied columns:

$$P_u = 0.52 A_g [0.85 f'_c (1 - \rho_g) + f_y \rho_g] \quad (17.11)$$

The design procedure involves the following:

1. Determine the factored design load for various load combinations.
2. Assume  $\rho_g = 0.03$ . A lower or higher value could be taken depending upon a bigger or smaller size of column being acceptable.
3. Determine the gross area,  $A_g$ , from Equation 17.10 or 17.11. Select the column dimensions to a full-inch increment.
4. For the actual gross area, calculate the adjusted steel area from Equation 17.6 or 17.7. Make the selection of steel using Appendix D, Table D.2 and check from Appendix D, Table D.14 that the number of bars can fit in a single row of the column.
5. (For spirals) select the spiral size and pitch from Appendix D, Table D.13. (For ties) select the size of tie, decide the spacing, and arrange ties as per item 5 of "Specifications for Columns" section.
6. Sketch the design.

### Example 17.3

Design a tied column for an axial service dead load of 200 k and service live load of 280 k. Use  $f'_c = 4,000 \text{ psi}$  and  $f_y = 60,000 \text{ psi}$ .

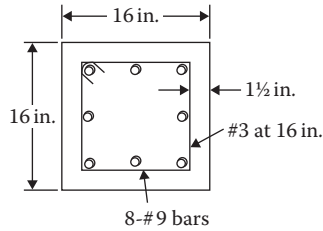


FIGURE 17.4 Tied column section of Example 17.3.

### SOLUTION

1.  $P_u = 1.2(200) + 1.6(280) = 688$  k
2. For  $\rho_g = 0.03$ , from Equation 17.11,

$$A_g = \frac{P_u}{0.52[0.85f'_c(1-\rho_g) + f_y\rho_g]}$$

$$= \frac{688}{0.52[0.85(4)(1-0.03) + 60(0.03)]}$$

$$= 259.5 \text{ in.}^2$$

For a square column,  $h = \sqrt{259.5} = 16.1$  in., use 16 in.  $\times$  16 in.,  $A_g = 256$  in.<sup>2</sup>

3. From Equation 17.7,  
 $688 = 0.52 [0.85(4)(256 - A_{st}) + 60(A_{st})]$   
 $688 = 0.52(870.4 + 56.6A_{st})$   
 $A_{st} = 8$  in.<sup>2</sup>  
 Select 8 bars of #9 size,  $A_{st}$  (provided) = 8 in.<sup>2</sup>

From Appendix D, Table D.14, for a core size of  $16 - 3 = 13$  in., 8 bars of #9 size can be arranged in a row.

4. Design of ties:
  - a. Select #3 size
  - b. Spacing should be the smaller of the following:
    - i.  $16(1.128) = 18$  in.
    - ii.  $48(0.375) = 18$  in.
    - iii. 16 in.  $\leftarrow$  Controls
  - c. Clear distance  
 $16 = 2(\text{cover}) + 2(\text{tie diameter}) + 3(\text{bar diameter}) + 2(\text{spacing})$   
 $16 = 2(1.5) + 2(0.375) + 3(1.128) + 2s$   
 or  $s = 4.43$  in.  $<$  6 in. **OK**
5. The sketch is shown in Figure 17.4.

### Example 17.4

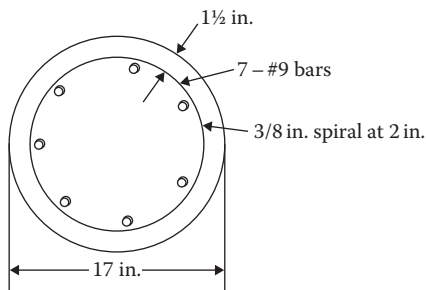
For Example 17.3, design a circular spiral column.

### SOLUTION

1.  $P_u = 1.2(200) + 1.6(280) = 688$  k
2. For  $\rho_g = 0.03$ , from Equation 17.10,

$$A_g = \frac{P_u}{0.60[0.85f'_c(1-\rho_g) + f_y\rho_g]}$$

$$= \frac{688}{0.60[0.85(4)(1-0.03) + 60(0.03)]} = 225 \text{ in.}^2$$



**FIGURE 17.5** Spiral column of Example 17.4.

For a circular column,  $\frac{\pi h^2}{4} = 225$ ,  $h = 16.93$  in., use 17 in.,  $A_g = 227$  in.<sup>2</sup>

3. From Equation 17.6,

$$688 = 0.60 [0.85(4)(227 - A_{st}) + 60(A_{st})]$$

$$688 = 0.60(771.8 + 56.6 A_{st})$$

$$\text{or } A_{st} = 6.62 \text{ in.}^2$$

Select 7 bars of #9 size,  $A_{st}$  (provided) = 7 in.<sup>2</sup>

From Appendix D, Table D.14, for a core size of  $17 - 3 = 14$  in., 9 bars of #9 can be arranged in a single row. **OK**

4. Design of spiral:

a. From Appendix D, Table D.13, for 17 in. diameter column,  
 spiral size = 3/8 in.  
 pitch = 2 in.

b. Clear distance  
 $2 - 0.375 = 1.625$  in. > 1 in. **OK**

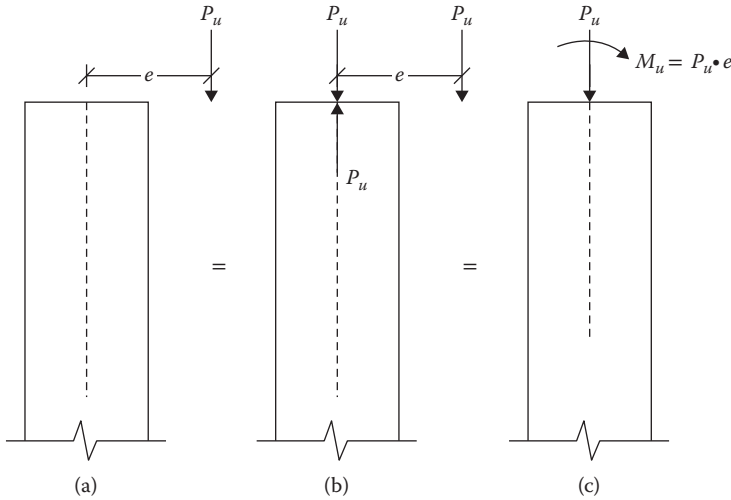
5. The sketch is shown in Figure 17.5.

## SHORT COLUMNS WITH COMBINED LOADS

Most of the reinforced concrete columns belong to this category. The condition of an axial loading or a small eccentricity is rare. The rigidity of the connection between beam and column makes the column rotate with the beam resulting in a moment at the end. Even an interior column of equally spanned beams will receive unequal loads due to variations in the applied loads, producing a moment on the column.

Consider that a load,  $P_u$ , acts at an eccentricity,  $e$ , as shown in Figure 17.6a. Apply a pair of loads  $P_u$ , one acting up and one acting down through the column axis, as shown in Figure 17.6b. The applied loads cancel each other and, as such, have no technical significance. When we combine the load  $P_u$  acting down at an eccentricity  $e$  with the load  $P_u$  acting upward through the axis, a couple,  $M_u = P_u e$ , is produced. In addition, the downward load  $P_u$  acts through the axis. Thus, a system of force acting at an eccentricity is equivalent to a force and a moment acting through the axis, as shown in Figure 17.6c. Inverse to this, a force and a moment when acting together are equivalent to a force acting with an eccentricity.

As discussed with wood and steel structures, buckling is a common phenomenon associated with columns. However, concrete columns are stocky and a great number of columns are not affected by buckling. These are classified as the *short columns*. It is the slenderness ratio that determines



**FIGURE 17.6** Equivalent force system on a column: (a) eccentric load on a column, (b) equivalent loaded column with axial and eccentric loads, and (c) equivalent column with axial load and moment.

whether a column could be considered a short or a slender (long) column. The ACI sets the following limits when it is a short column and the slenderness effects could be ignored:

- a. For members not braced against sidesway:

$$\frac{Kl}{r} \leq 22 \tag{17.12}$$

- b. For members braced against sidesway:

$$\frac{Kl}{r} \leq 34 - 12 \left( \frac{M_1}{M_2} \right) \tag{17.13a}$$

or

$$\frac{Kl}{r} \leq 40 \tag{17.13b}$$

where

$M_1$  and  $M_2$  are small and large end moments. The ratio  $M_1/M_2$  is positive if a column bends in a single curvature, that is, the end moments have opposite signs. It is negative for a double curvature when the end moments have the same sign. (This is opposite of the sign convention for steel in the “Magnification Factor,  $B_1$ ” section in Chapter 12.)

$l$  is length of column

$K$  is effective length factor given in Figure 7.6 and the alignment charts in Figures 10.5 and 10.6

$r$  = radius of gyration =  $\sqrt{I/A}$   
 =  $0.3h$  for rectangular column  
 =  $0.25h$  for circular column

If a clear bracing system is not visible, the ACI provides certain rules to decide whether a frame is braced or unbraced. However, conservatively it can be assumed to be unbraced.

The effective length factor has been discussed in detail in the “Column Stability Factor” section in Chapter 7, and the “Effective Length Factor for Slenderness Ratio” section in Chapter 10. For columns braced against sidesway, the effective length factor is 1 or less; conservatively it can be set as 1. For members subjected to sidesway, the effective length factor is greater than 1. It is 1.2 for a column fixed at one end and the other end has the rotation fixed but is free to translate (sway).

### EFFECTS OF MOMENT ON SHORT COLUMNS

To consider the effect of an increasing moment (eccentricity) together with an axial force on a column, the following successive cases have been presented accompanied with respective stress/strain diagrams.

#### ONLY AXIAL LOAD ACTING

The entire section will be subjected to a uniform compression stress,  $\sigma_c = P_u/A_g$ , and a uniform strain of  $\epsilon = \sigma_c/E_c$ , as shown in Figure 17.7. The column will fail by the crushing of concrete. By another measure the column will fail when the compressive concrete strain reaches 0.003. In the following other cases, the strain measure will be considered because the strain diagrams are linear. The stress variations in concrete are nonlinear.

#### LARGE AXIAL LOAD AND SMALL MOMENT (SMALL ECCENTRICITY)

Due to axial load there is a uniform strain,  $-\epsilon_c$ , and due to moment, there is a bending strain of compression on one side and tension on the other side. The sum of these strains is shown in the last diagram of Figure 17.8b. As the maximum strain due to the axial load and moment together cannot exceed 0.003, the strain due to the load will be smaller than 0.003 because a part of the contribution is made by the moment. Hence, the axial load  $P_u$  will be smaller than the previous case.

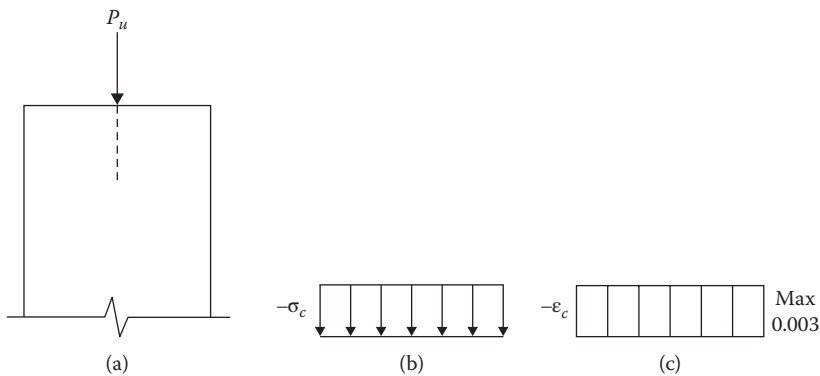


FIGURE 17.7 Axial load only on column: (a) load on column, (b) stress, (c) strain.

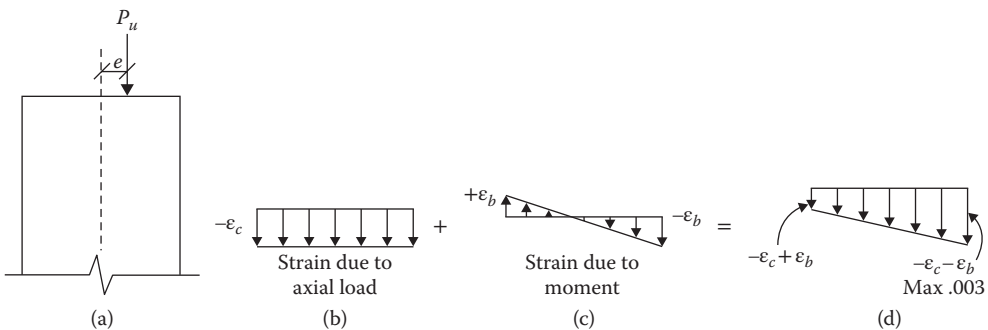


FIGURE 17.8 Axial load with small moment on column: (a) load on column, (b) axial strain, (c) bending strain, (d) combined strain.

**LARGE AXIAL LOAD AND MOMENT LARGER THAN CASE 2 SECTION**

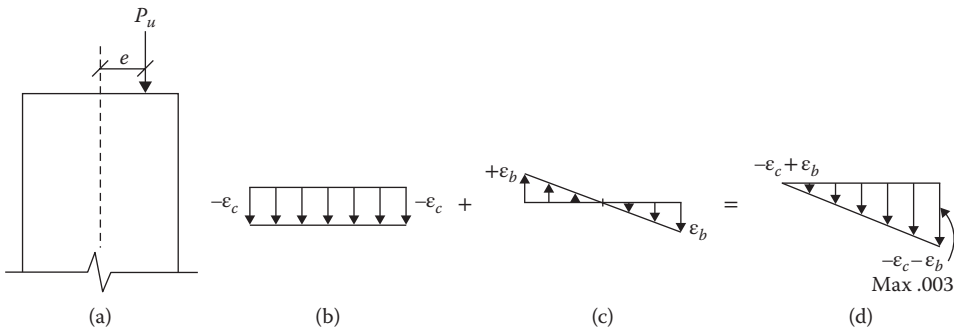
This is a case when the strain is zero at one face. To attain the maximum crushing strain of 0.003 on the compression side, the strain contribution from both the axial load and moment will be 0.0015.

**LARGE AXIAL LOAD AND MOMENT LARGER THAN CASE 3 SECTION**

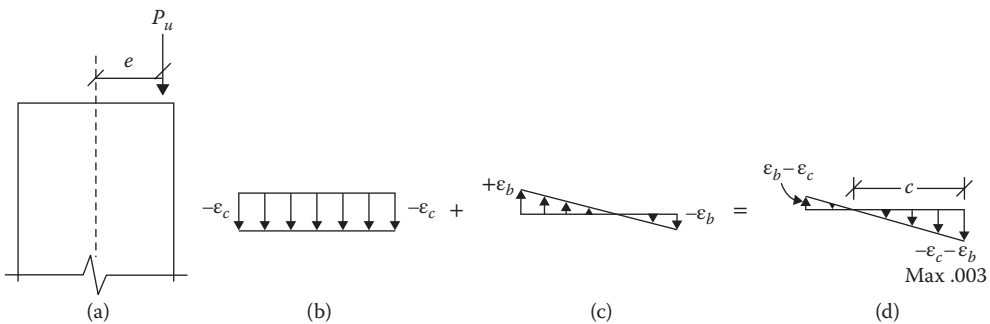
When the moment (eccentricity) increases somewhat from the previous case, the tension will develop on one side of the column as the bending strain will exceed the axial strain. The entire tensile strain contribution will come from steel.\* The concrete on the compression side will contribute to compression strain. The strain diagram will be as shown in Figure 17.10d. The neutral axis (the point of zero strain) will be at a distance  $c$  from the compression face. As the strain in steel is less than yielding, the failure will occur by crushing of concrete on the compression side.

**BALANCED AXIAL LOAD AND MOMENT**

As the moment (eccentricity) continues to increase, the tensile strain steadily rises. A condition will be reached when the steel on the tension side will attain the yield strain,  $\epsilon_y = f_y/E$  (for Grade 60 steel, this strain is 0.002), simultaneously as the compression strain in concrete reaches the crushing strain of 0.003. The failure of concrete will occur at the same time as steel yields. This is known as the *balanced condition*. The strain diagrams in this case are shown in Figure 17.11. The value of  $c$  in Figure 17.11d is less as compared to the previous case, that is, the neutral axis moves up toward the compression side.



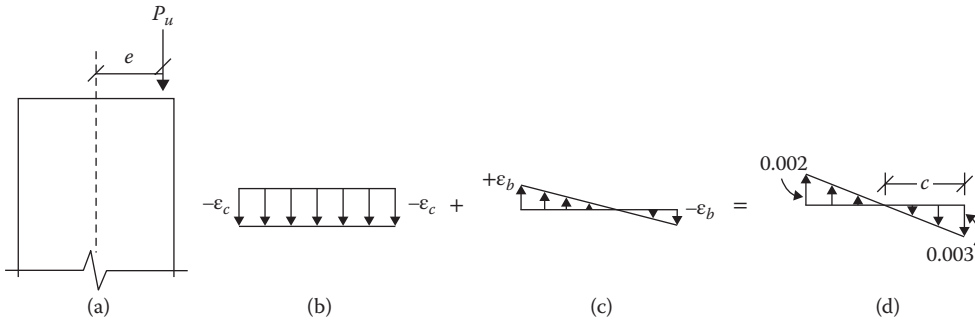
**FIGURE 17.9** Axial load and moment (Case 3) on column: (a) load on column, (b) axial strain, (c) bending strain, (d) combined strain.



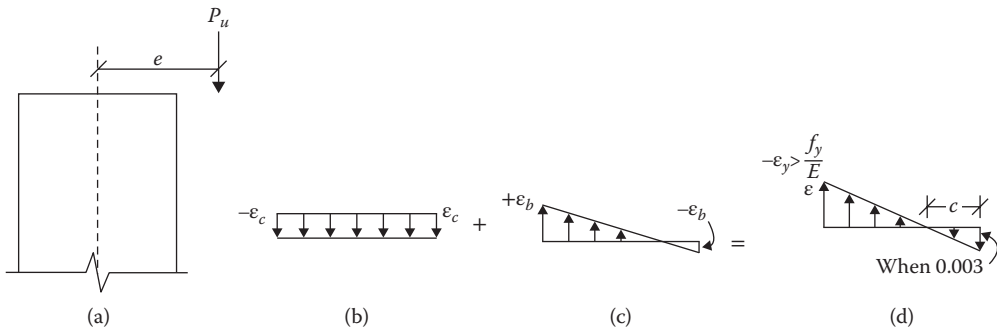
**FIGURE 17.10** Axial load and moment (Case 4) on column: (a) load on column, (b) axial strain, (c) bending strain, (d) combined strain.

\* The concrete being weak in tension, its contribution is neglected.





**FIGURE 17.11** Balanced axial load and moment (Case 5) on column: (a) load on column, (b) axial strain, (c) bending strain, (d) combined strain.



**FIGURE 17.12** Small axial load and large moment (Case 6) on column: (a) load on column, (b) axial strain, (c) bending strain, (d) combined strain.

**SMALL AXIAL LOAD AND LARGE MOMENT**

As the moment (eccentricity) is further increased, steel will reach to the yield strain,  $\epsilon_y = f_y/E$ , before concrete attains the crushing strain of 0.003. In other words, when compared to the concrete strain of 0.003, the steel strain has already exceeded its yield limit,  $\epsilon_y$ , as shown in Figure 17.12d. The failure will occur by yielding of steel. This is called the *tension-controlled condition*.

**NO APPRECIABLE AXIAL LOAD AND LARGE MOMENT**

This is the case when the column acts as a beam. The eccentricity is assumed to be at infinity. The steel has long before yielded prior to concrete reaching a level of 0.003. In other words, when compared to a concrete strain of 0.003, the steel strain is 0.005 or more. This is shown in Figure 17.13b.

As discussed in the “Axially Loaded Columns” section, when a member acts as a column, the strength (capacity) reduction factor,  $\phi$ , is 0.7 for spiral columns and 0.65 for tied columns. This is the situation for Cases 1 through 5. For beams, as in Case 7, the factor is 0.9. For Case 6, between the column and the beam condition, the magnitude of  $\phi$  is adjusted by Equation 14.13, based on the value of strain in steel,  $\epsilon_t$ .

If the magnitudes of the axial loads and the moments for all seven cases are plotted, it will appear like the shape shown in Figure 17.14. This is known as the *interaction diagram*.

**CHARACTERISTICS OF THE INTERACTION DIAGRAM**

The interaction diagram presents the capacity of a column for various proportions of the loads and moments. Any combination of loading that falls inside the diagram is satisfactory whereas any combination falling outside represents a failure condition.

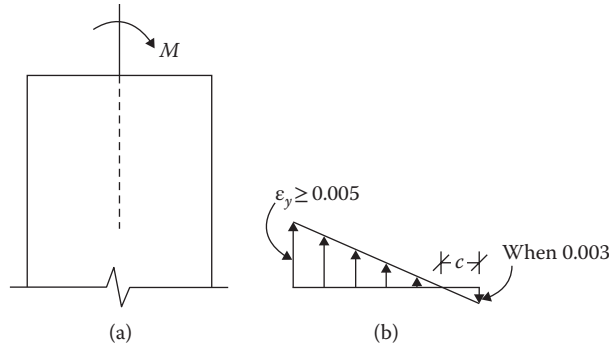


FIGURE 17.13 Moment only column (Case 7): (a) load on column, (b) combined strain.

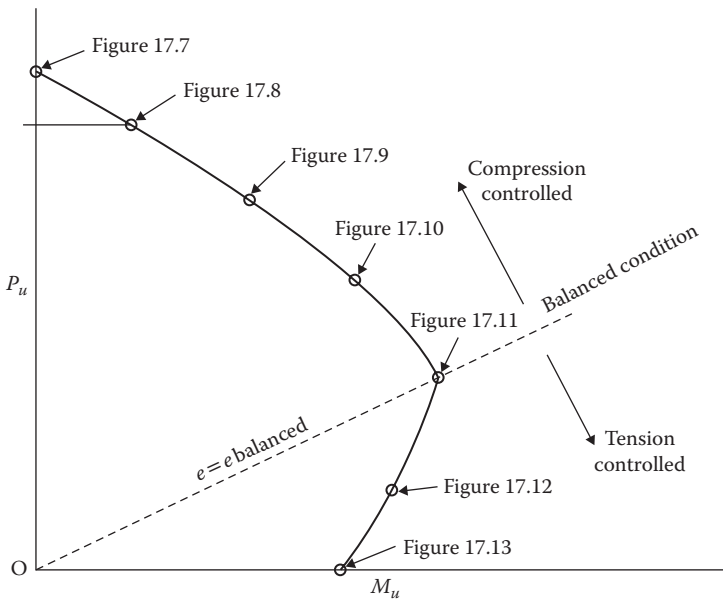


FIGURE 17.14 Column interaction diagram.

From Cases 1 through 5 where compression control exists, as the axial load decreases the moment capacity increases. Below this stage, the position is different. First of all, for the same moment, the axial capacity is higher in the compression control zone than in the tensile control zone. Further in the tensile control zone, as the axial load increases the moment capacity also increases. This is due to the fact that any axial compression load tends to reduce the tensile strain (and stress), which results in raising of the moment-resisting capacity.

Any radial line drawn from origin  $O$  to any point on the diagram represents a constant eccentricity, that is, a constant ratio of the moment to the axial load. A line from point  $O$  to a point on the diagram for the “Balanced Axial Load and Moment” (Case 5) condition represents the  $e_{balanced}$  eccentricity.

Within the same column, as the amount of steel varies, although the shape of the diagram (curve) remains similar to Figure 17.4, the location of the curve shifts to represent the appropriate magnitudes of the axial force and the moment; that is, the shapes of the curves are parallel.

The interaction diagram serves as a very useful tool in the analysis and design of columns for the combined loads.

### APPLICATION OF THE INTERACTION DIAGRAM

The ACI has prepared the interaction diagrams in dimensionless units for rectangular and circular columns with different arrangements of bars for various grades of steel and various strengths of concrete. The abscissa has been represented as  $R_n = M_u / \phi f'_c A_g h$  and the ordinate as  $K_n = P_u / \phi f'_c A_g$ . Several of these diagrams for concrete strength of 4,000 psi and steel strength of 60,000 psi are included in Appendix D, Tables D.15 through D.22.

On these diagrams, the radial strain line of value = 1 represents the balanced condition. Any point on or above this line represents compression control and  $\phi = 0.7$  (spiral) or 0.65 (tied). Similarly the line of  $\epsilon_t = 0.005$  represents that the steel has yielded or beam behavior. Any point on or below this line will have  $\phi = 0.9$ . In between these two lines is the transition zone for which  $\phi$  has to be corrected by Equation 14.13.

The line labeled  $K_{max}$  indicates the maximum axial load with the limiting small eccentricity of  $0.05h$  for spiral and  $0.1h$  for tied columns.

The other terms in these diagrams are

1.  $\rho_g = \frac{A_{st}}{A_g}$
2.  $h$  = column dimension in line with eccentricity (perpendicular to the plane of bending)
3.  $\gamma = \frac{\text{center-to-center distance of outer row of steel}}{h}$  (17.14)
4. Slope of radial line from origin =  $h/e$

### ANALYSIS OF SHORT COLUMNS FOR COMBINED LOADING

This involves determining the axial load strength and the moment capacity of a known column. The steps comprise the following:

1. From Equation 17.12 or 17.13, confirm that it is a short column (there is no slenderness effect).
2. Calculate the steel ratio,  $\rho_g = A_{st}/A_g$ , and check for the value to be between 0.01 and 0.08.
3. Calculate  $\gamma$  from Equation 17.14
4. Select the right interaction diagram to be used based on  $\gamma$ , type of cross section,  $f'_c$ , and  $f_y$ .
5. Calculate the slope of the radial line =  $h/e$
6. Locate a point for coordinates  $K_n = 1$  and  $R_n = 1/\text{slope}$ , or  $R_n = e/h$  (or for any value of  $K_n$ ,  $R_n = K_n e/h$ ). Draw a radial line connecting the coordinate point to the origin. Extend the line to intersect with  $\rho_g$  of step 2. If necessary, interpolate the interaction curve.
7. At the intersection point, read  $K_n$  and  $R_n$ .
8. If the intersection point is on or above the strain line = 1,  $\phi = 0.7$  or 0.65. If it is on or below  $\epsilon_t = 0.005$ ,  $\phi = 0.9$ . If it is in between, correct  $\phi$  by Equation 14.13. This correction is rarely applied.
9. Compute  $P_u = K_n \phi f'_c A_g$  and  $M_u = R_n \phi f'_c A_g h$ .

#### Example 17.5

A 10 ft. long braced column with a cross section is shown in Figure 17.15. Find the axial design load and the moment capacity for an eccentricity of 6 in. The end moments are equal and have the same sign. Use  $f'_c = 4,000$  psi and  $f_y = 60,000$  psi.

#### SOLUTION

1. For same sign (double curvature),  $\frac{M_1}{M_2} = -1$ .
2.  $K = 1$  (braced),  $l = 10 \times 12 = 120$  in.,  $r = 0.3h = 0.3(16) = 4.8$  in.

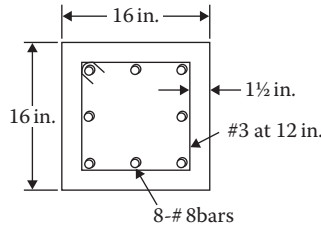


FIGURE 17.15 Eccentrically loaded column for Example 17.5.

$$3. \frac{Kl}{r} = \frac{1(120)}{4.8} = 25$$

4. Limiting value from Equation 17.13

$$\begin{aligned} \frac{Kl}{r} &= 34 - 12 \left( \frac{M_1}{M_2} \right) \\ &= 34 - 12(-1) = 46 > 40 \end{aligned}$$

Limit value of 40 used

Since step (3) < step (4), short column

$$5. A_g = 16 \times 16 = 256 \text{ in.}^2$$

$$A_{st} = 6.32 \text{ in.}^2$$

$$\rho_g = \frac{6.32}{256} = 0.025$$

$$6. \text{ Center to center of steel} = 16 - 2(\text{cover}) - 2(\text{tie diameter}) - 1(\text{bar diameter}) \\ = 16 - 2(1.5) - 2(0.375) - 1(1) = 11.25 \text{ in.}$$

$$\gamma = \frac{11.25}{16} = 0.70$$

7. Use the interaction diagram in Appendix D, Table D.17

$$8. \text{ slope} = \frac{h}{e} = \frac{16}{6} = 2.67$$

$$9. K_n = 1, R_n = \frac{1}{\text{slope}} = \frac{1}{2.67} = 0.375$$

Draw a radial line connecting the aforementioned coordinates to origin

$$10. \text{ At } \rho_g = 0.025, K_n = 0.48 \text{ and } R_n = 0.18$$

$$11. \text{ The point is above the line where strain} = 1, \text{ hence } \phi = 0.65$$

$$12. P_u = K_n \phi f'_c A_g = 0.48(0.65)(4)(256) = 319.5 \text{ k}$$

$$M_u = R_n \phi f'_c A_g h = 0.18(0.65)(4)(256)(16) = 1917 \text{ in.-k or } 159.74 \text{ ft.-k.}$$

## DESIGN OF SHORT COLUMNS FOR COMBINED LOADING

This involves determining the size, selecting steel, and fixing ties or spirals for a column. The steps are as follows:

1. Determine the design-factored axial load and moment.
2. Based on  $\rho_g = 1\%$  and axial load only, estimate the column size by Equation 17.10 or 17.11, rounding on the lower side.
3. For a selected size (diameter) of bars, estimate  $\gamma$  for the column size of step 2.
4. Select the right interaction diagram based on  $f'_c$ ,  $f_y$ , the type of cross section, and  $\gamma$  of step 3.
5. Calculate  $K_n = P_u / \phi f'_c A_g$  and  $R_n = M_u / \phi f'_c A_g h$ , assuming  $\phi = 0.7$  (spiral) or 0.65 (ties).

6. Entering the appropriate diagram at Appendix D, Tables D.15 through D.22, read  $\rho_g$  at the intersection point of  $K_n$  and  $R_n$ . This should be less than 0.05. If not, change the dimension and repeat steps 3–6.
7. Check that the interaction point of step 6 is above the line where strain = 1. If not adjust  $\phi$  and repeat steps 5 and 6.
8. Calculate the required steel area,  $A_{st} = \rho_g A_g$  and select reinforcement from Appendix D, Table D.2 and check that it fits in one row from Appendix D, Table D.14.
9. Design ties or spirals from steps 5 and 6 of the “Specification for Columns” section.
10. Confirm from Equation 17.12 or 17.13 that the column is short (no slenderness effect).

### Example 17.6

Design a 10 ft. long circular spiral column for a braced system to support service dead and live loads of 300 k and 460 k, respectively, and service dead and live moments of 100 ft.-k each. The moment at one end is zero. Use  $f'_c = 4,000$  psi and  $f_y = 60,000$  psi.

### SOLUTION

1.  $P_u = 1.2(300) + 1.6(460) = 1096$  k  
 $M_u = 1.2(100) + 1.6(100) = 280$  ft.-k or 3360 in.-k
2. Assume  $\rho_g = 0.01$ , from Equation 17.10:

$$\begin{aligned} A_g &= \frac{P_u}{0.60[0.85f'_c(1-\rho_g) + f_y\rho_g]} \\ &= \frac{1096}{0.60[0.85(4)(1-0.01) + 60(0.01)]} \\ &= 460.58 \text{ in.}^2 \end{aligned}$$

$$\frac{\pi h^2}{4} = 460.58$$

or  $h = 24.22$  in.

Use  $h = 24$  in.,  $A_g = 452$  in.<sup>2</sup>

3. Assume #9 size of bar and 3/8 in. spiral center-to-center distance  
 Center to center distance = 24 – 2(cover) – 2(spiral diameter) – 1(bar diameter)  
 = 24 – 2(1.5) – 2(3/8) – 1.128 = 19.12 in.

$$\gamma = \frac{19.12}{24} = 0.8$$

Use the interaction diagram in Appendix D, Table D.21

4.  $K_n = \frac{P_u}{\phi f'_c A_g} = \frac{1096}{(0.7)(4)(452)} = 0.866$   
 $R_n = \frac{M_u}{\phi f'_c A_g h} = \frac{3360}{(0.7)(4)(452)(24)} = 0.11$

5. At the intersection point of  $K_n$  and  $R_n$ ,  $\rho_g = 0.025$
6. The point is above the strain line = 1, hence  $\phi = 0.7$  **OK**
7.  $A_{st} = (0.025)(452) = 11.3$  in.<sup>2</sup>

From Appendix D, Table D.2, select 12 bars of #9,  $A_{st} = 12$  in.<sup>2</sup>

From Appendix D, Table D.14 for a core diameter of 24 – 3 = 21 in., 15 bars of #9 can be arranged in a row

## 8. Selection of spirals

From Appendix D, Table D.13, size = 3/8 in., pitch = 2 1/4 in.

Clear distance = 2.25 - 3/8 = 1.875 > 1 in. **OK**

9.  $K = 1$ ,  $l = 10 \times 12 = 120$  in.,  $r = 0.25(24) = 6$  in.

$$\frac{Kl}{r} = \frac{1(120)}{6} = 20$$

$$\left( \frac{M_1}{M_2} \right) = 0$$

$$34 - 12 \left( \frac{M_1}{M_2} \right) = 34$$

Because  $(Kl/r) \leq 34$ , short column.

## LONG OR SLENDER COLUMNS

When the slenderness ratio of a column exceeds the limits given by Equation 17.12 or 17.13, it is classified as a *long* or *slender* column. In a physical sense, when a column bends laterally by an amount,  $\Delta$ , the axial load,  $P$ , introduces an additional moment equal to  $P \Delta$ . When this  $P \Delta$  moment cannot be ignored, the column is a long or slender column.

There are two approaches to deal with this additional or secondary moment. The nonlinear second-order analysis is based on a theoretical analysis of the structure under application of an axial load, a moment, and the deflection. As an alternative approach, the ACI provides a first-order method that magnifies the moment acting on the column to account for the  $P-\Delta$  effect. The magnification expressions for the braced (nonsway) and unbraced (sway) frames are similar to the steel magnification factors discussed in the “Magnification Factor,  $B_1$ ” section in Chapter 12 and the “Magnification Factor for Sway,  $B_2$ ” section in Chapter 12. After the moments are magnified, the procedure for short columns from the “Analysis of Short Columns for Combined Loading” and “Design of Short Columns for Combined Loading” sections can be applied for analysis and design of the column using the interaction diagrams.

The computation of the magnification factors is appreciably complicated for concrete because of the involvement of the modulus of elasticity of concrete and the moment of inertia with creep and cracks in concrete.

A large percent of columns do not belong to the slender category. It is advisable to avoid the slender columns whenever possible by increasing the column dimensions, if necessary. As a rule of thumb, a column dimension of one-tenth of the column length in braced frames will meet the short column requirement. For a 10 ft. length, a column of 1 ft. or 12 in. or more will be a short braced column. For unbraced frames, a column dimension one-fifth of the length will satisfy the short column requirement. A 10 ft. long unbraced column of 2 ft. or 24 in. dimension will avoid the slenderness effect.

## PROBLEMS

- 17.1** Determine the design axial load capacity and check whether the reinforcements meet the specifications for the column shown in Figure P17.1. Use  $f'_c = 4,000$  psi and  $f_y = 60,000$  psi.
- 17.2** Determine the design axial load capacity and check whether the reinforcements meet the specifications for the column shown in Figure P17.2. Use  $f'_c = 4,000$  psi and  $f_y = 60,000$  psi.

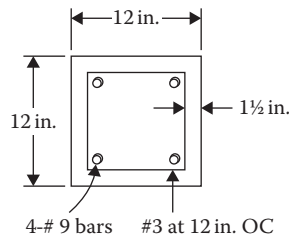


FIGURE P17.1 Column section for Problem 17.1.

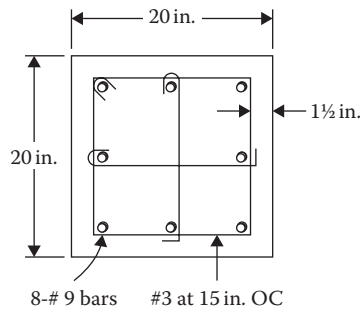


FIGURE P17.2 Column section for Problem 17.2.

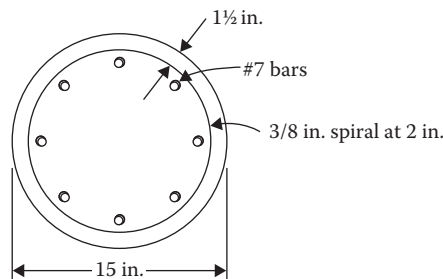


FIGURE P17.3 Column section for Problem 17.3.

- 17.3 Determine the design axial load capacity of the column in Figure P17.3 and check whether the reinforcement is adequate. Use  $f'_c = 5,000$  psi and  $f_y = 60,000$  psi.
- 17.4 Determine whether the maximum service dead load and live load carried by the column shown in Figure P17.4 are equal. Check for spiral steel. Use  $f'_c = 3,000$  psi and  $f_y = 40,000$  psi.
- 17.5 Compute the maximum service live load that may be axially placed on the column shown in Figure P17.5. The service dead load is 150 k. Check for ties specifications. Use  $f'_c = 3,000$  psi and  $f_y = 40,000$  psi.
- 17.6 A service dead load of 100 k and service live load of 450 k are axially applied on a 20 in. diameter circular column reinforced with six #8 bars. The cover is 1 1/2 in. and the spiral size is 1/2 in. at a 2 in. pitch. Is the column adequate? Use  $f'_c = 4,000$  psi and  $f_y = 60,000$  psi.
- 17.7 Design a tied column to carry a factored axial design load of 900 k. Use  $f'_c = 5,000$  psi and  $f_y = 60,000$  psi.
- 17.8 For Problem 17.7, design a circular spiral column.

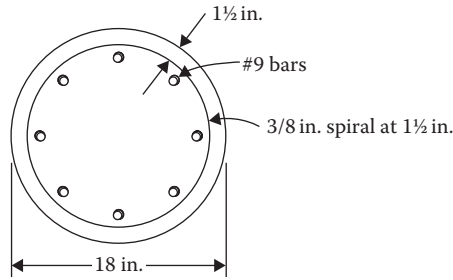


FIGURE P17.4 Column section for Problem 17.4.

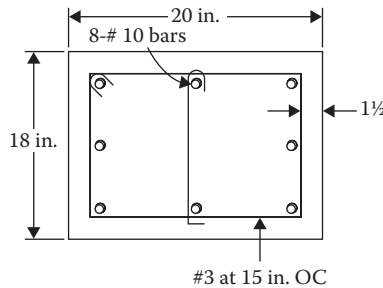


FIGURE P17.5 Column section for Problem 17.5.

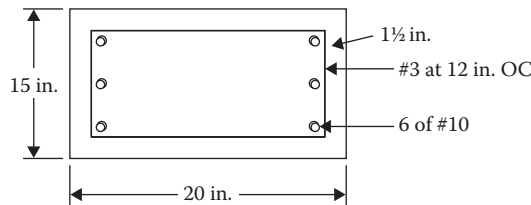
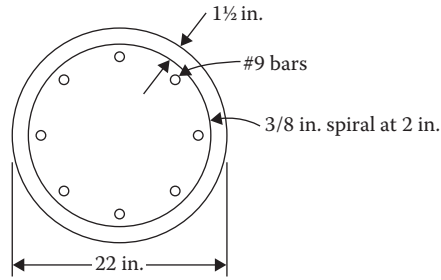


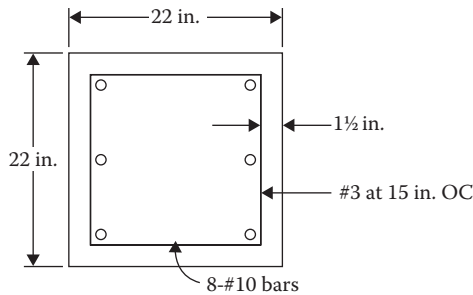
FIGURE P17.6 Column section for Problem 17.13.

- 17.9** Design a tied column to support a service dead axial load of 300 k and live load of 480 k. Use  $f'_c = 4,000$  psi and  $f_y = 60,000$  psi.
- 17.10** Redesign a circular spiral column for Problem 17.9.
- 17.11** Design a rectangular tied column to support an axial service dead load of 400 k and live load of 590 k. The larger dimension of the column is approximately twice the shorter dimension. Use  $f'_c = 5,000$  psi and  $f_y = 60,000$  psi.
- 17.12** Design the smallest circular spiral column to carry an axial service dead load of 200 k and live load of 300 k. Use  $f'_c = 3,000$  psi and  $f_y = 60,000$  psi. [Hint: For the smallest dimension, use 8% steel and it is desirable to use #11 steel to reduce the number of bars to be accommodated in a single row.]
- 17.13** For the 8 ft. long braced column shown in Figure P17.6, determine the axial load strength and the moment capacity at an eccentricity of 5 in in the larger dimension. Use  $f'_c = 4,000$  psi and  $f_y = 60,000$  psi.
- 17.14** An unbraced column shown in Figure P17.7 has a length of 8 ft. and a cross section as shown. The factored moment-to-load ratio on the column is 0.5 ft. Determine the strength of the column.  $K = 1.2$ . Use  $f'_c = 4,000$  psi and  $f_y = 60,000$  psi.
- 17.15** On a 10 ft. long column of an unbraced frame system, the load acts at an eccentricity of 5 in. The column section is shown in Figure P17.8. What are the axial load capacity and moment strength of the column? Use  $f'_c = 4,000$  psi and  $f_y = 60,000$  psi.





**FIGURE P17.7** Column section for Problem 17.14.



**FIGURE P17.8** Column section for Problem 17.15.

- 17.16** Design a 8 ft. long circular spiral column of a braced system to support a factored axial load of 1200 k and a factored moment of 300 ft.-k. The end moments are equal and have the same signs. Use  $f'_c = 4,000$  psi and  $f_y = 60,000$  psi.
- 17.17** Design a tied column for Problem 17.16. Arrange the reinforcement on all faces.
- 17.18** For an unbraced frame, design a circular column of 10 ft. length that supports service dead and live loads of 400 k and 600 k, respectively, and service dead and live moments of 120 ft.-k and 150 ft.-k, respectively. The end moments are equal and have opposite signs.  $K = 1.2$ . Use  $f'_c = 4,000$  psi and  $f_y = 60,000$  psi.
- 17.19** Design a tied column for Problem 17.18 having reinforcement on all faces.
- 17.20** A braced frame has a 10 ft. long column. Design a tied column with reinforcing bars on two end faces only to support the following service loads and moments. If necessary, adjust the column dimensions to qualify it as a short column. The column has equal end moments and a single curvature. Use  $f'_c = 4,000$  psi and  $f_y = 60,000$  psi.  
 $P_D = 150$  k,  $P_L = 200$  k  
 $M_D = 50$  ft.-k,  $M_L = 70$  ft.-k.



---

# Bibliography

- Alsamsam, I. M. and Kamara, M. E. (eds.), *Simplified Design: Reinforced Concrete Buildings of Moderate Size and Height*, 3rd Ed., Portland Cement Association, Skokie, IL, 2004.
- Ambrose, J. and Tripeny, P., *Simplified Engineering for Architects and Builders*, John Wiley & Sons, Hoboken, NJ, 2006.
- Ambrose, J. and Tripeny, P., *Building Structures*, 3rd Ed., John Wiley & Sons, Hoboken, NJ, 2011.
- American Concrete Institute, *ACI Design Handbook*, SP-17, American Concrete Institute, Farmington Hills, MI, 1997.
- American Concrete Institute, *Building Code Requirements for Structural Concrete and Commentary*, ACI 318-11, American Concrete Institute, Farmington Hills, MI, 2011.
- American Forest & Paper Association, *ASD/LRFD Manual for Engineered Wood Construction*, 2012 Ed., AF&PA American Wood Council, Washington, DC, 2012.
- American Forest & Paper Association, *National Design Specification for Wood Construction*, 2012 Ed., AF&PA American Wood Council, Washington, DC, 2012.
- American Forest & Paper Association, *National Design Specification Supplement, Design Values for Wood Construction*, AF&PA American Wood Council, Washington, DC, 2012.
- American Forest & Paper Association, *Solved Example Problems, ASD/LRFD*, 2005 Ed., AF&PA American Wood Council, Washington, DC, 2006.
- American Forest & Paper Association, *Special Design Provisions for Wind and Seismic, ASD/LRFD*, 2008 Ed., AF&PA American Wood Council, Washington, DC, 2009.
- American Institute of Steel Construction, *Steel Construction Manual*, 14th Ed. (2010 AISC Specifications), American Institute of Steel Construction, Chicago, IL, 2011.
- American Institute of Steel Construction, *Seismic Design Manual*, 2nd Ed. (2010 AISC Specifications), American Institute of Steel Construction, Chicago, IL, 2013.
- American Institute of Timber Construction, *Timber Construction Manual*, 6th Ed., John Wiley & Sons, Hoboken, NJ, 2012.
- American Society of Civil Engineers, *Minimum Design Loads for Buildings and Other Structures*, ASCE 7-10, American Society of Civil Engineers, Reston, VA, 2010.
- Breyer, D. E. et al., *Design of Wood Structures, ASD/LRFD*, 6th Ed., McGraw-Hill, New York, NY, 2007.
- Brockenbrough, R. L. and Merritt, F. S., *Structural Steel Designer's Handbook*, 5th Ed., ASCE Press, Reston, VA, 2011.
- Buckner, C. D., *Concrete Design for the Civil and Structural PE Exams*, Professional Publications, Belmont, CA, 2012.
- Building Seismic Safety Council, *NEHRP Recommended Provisions: Design Examples*, FEMA 451, National Institute of Building Sciences, Washington, DC, 2006.
- Building Seismic Safety Council, *NEHRP Recommended Seismic Provisions for New Buildings and Other Structures*, 2009 Ed., FEMA P-750, National Institute of Building Sciences, Washington, DC, 2009.
- Ching, F. D. and Winkel, S. R., *Building Codes Illustrated: A Guide to Understanding the 2012 International Building Code*, 4th Ed., John Wiley & Sons, Hoboken, NJ, 2012.
- Concrete Reinforcing Steel Institute, *Manual of Standard Practice*, 28th Ed., Concrete Reinforcing Steel Institute, Chicago, IL, 2009.
- Fanella, D. A., *Seismic Detailing of Concrete Buildings*, 2nd Ed., Portland Cement Association, Skokie, IL, 2007.
- Federal Emergency Management Agency, *Seismic Load Analysis*, Federal Emergency Management Agency, Washington, DC, 2006.
- Fisher, J. M. et al., *Technical Digest No 11—Design of Lateral Load Resisting Frames Using Steel Joists and Joist Girders*, Steel Joist Institute, Myrtle Beach, SC, 2007.
- Galambos, T. V. et al., *Basic Steel Design with LRFD*, Prentice Hall, Englewood Cliffs, NJ, 1996.
- Geschwinder, L. F., *Design Steel Your Way with the 2005 AISC Specifications*, American Institute of Steel Construction, Chicago, IL, 2006.
- Ghosh, S. K. and Shen, Q., *Seismic and Wind Design of Concrete Buildings*, Portland Cement Association, Chicago, IL, 2009.

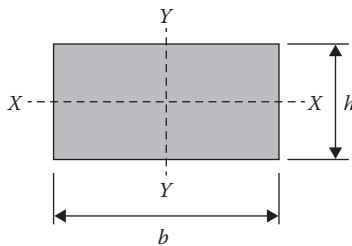
- Ghosh, S. K. et al., *Significant Changes to the Seismic Load Provisions of ASCE 7-10: An Illustrated Guide*, ASCE Press, Reston, VA, 2011.
- International Code Council, *International Building Code, 2012*, International Code Council, Country Club Hills, IL, 2011.
- International Code Council, *International Residential Code for One- and Two-Family Dwellings, 2012*, International Code Council, Country Club Hills, IL, 2011.
- Kamara, M. and Novak, L., *Simplified Design of Reinforced Concrete Buildings*, Portland Cement Association, Chicago, IL, 2011.
- Kamara, M. E. (ed.), *Notes on ACI 318-05 with Design Applications*, Portland Cement Association, Skokie, IL, 2005.
- Limbrunner, G. F. and Aghayere, A. O., *Reinforced Concrete Design*, 7th Ed., Prentice Hall, Englewood Cliffs, NJ, 2010.
- McCormac, J. C. and Brown, R. H., *Design of Reinforced Concrete*, 8th Ed., John Wiley & Sons, Hoboken, NJ, 2008.
- McCormac, J. C. and Csernak, S. F., *Structural Steel Design*, 5th Ed., Prentice Hall, Upper Saddle River, NJ, 2011.
- Mitchell, D. et al., *AASHTO LRFD Strut-and-Tie Model: Design Examples*, Engineering Bulletin, EB 231, Portland Cement Association, Skokie, IL, 2004.
- O'Rourke, M., *Snow Loads: Guide to the Snow Load Provisions of ASCE 7-10*, American Society of Civil Engineers, Reston, VA, 2010.
- Reese, R. C., *CRSI Design Handbook*, Literary Licensing, LLC, MT, 2012.
- Roland, F. S., *Steel Design for the Civil PE and Structural SE Exams*, Professional Publications, Belmont, CA, 2012.
- Segui, W. T., *Steel Design*, 5th Ed., Cengage Learning, Stamford, CT, 2012.
- Simiu, E. *Design of Buildings for Wind: A Guide for ASCE 7-10 Standard Users and Designers of Special Structures*, John Wiley & Sons, Hoboken, NJ, 2011.
- Stafford, T. E., *Significant Changes to the Wind Load Provisions of ASCE 7-10: An Illustrated Guide*, ASCE Press, Reston, VA, 2010.
- Steel Joist Institute, *Standard Specification for Joist Girders*, American National Standard SJI-JG-1.1, Revised November 2003, Steel Joist Institute, Forest, VA, 2005.
- Steel Joist Institute, *Standard Specification for Open Web Steel Joists, K-series*, American National Standard SJI-K-1.1, Revised November 2003, Steel Joist Institute, Forest, VA, 2005.
- Steel Joist Institute, *Standard Specifications and Load and Weight Tables for Steel Joists and Joist Girders*, 43rd Ed., Steel Joist Institute, Forest, VA, 2010.
- Steel Joist Institute, *SJI Publications Package*, Steel Joist Institute, Forest, VA, 2012.
- Underwood, R. and Chiuini, M., *Structural Design: A Practical Guide for Architects*, 2nd Ed., John Wiley & Sons, Hoboken, NJ, 2007.
- Whitney, C. S., Plastic theory of reinforced concrete design. *Transactions of the American Society of Civil Engineers*, 68, 1942, pp. 251–326.
- Wilden, H., FPCI (ed.), *PCI Design Handbook: Precast and Prestressed Concrete*, 7th Ed., Precast/Prestressed Concrete Institute, Chicago, IL, 2010.
- Williams, A., *Steel Structures Design, ASD/LRFD*, McGraw-Hill, New York, NY, 2011.
- Winkel, S. R. et al., *Building Codes Illustrated for Elementary and Secondary Schools*, John Wiley & Sons, Hoboken, NJ, 2007.
- Wright, J. K. and MacGregor, J. G., *Reinforced Concrete: Mechanics and Design*, 6th Ed., Prentice Hall, Upper Saddle River, NJ, 2011.

# Appendix A: General

**TABLE A.1**  
**Useful Conversion Factors**

Multiply	By	To Obtain
Pounds (m)	0.4356	Kilogram
Kilogram	2.205	Pounds (m)
Mass in slug	32.2	Weight in pound
Mass in kilogram	9.81	Weight in Newton (N)
Pound (f)	4.448	Newton
Newton	0.225	Pounds
U.S. or short ton	2000	Pounds
Metric ton	1000	Kilogram
U.S. ton	0.907	Metric ton
Foot	0.3048	Meter
Meter	3.281	Feet
Mile	5280	Feet
Mile	1609	Meter
	1.609	Kilometer
Square feet	0.0929	Square meter
Square mile	2.59	Square kilometer
Square kilometer	100	Hectare (ha)
Liter	1000	Cubic centimeter
Pounds per ft. <sup>2</sup>	47.88	N/m <sup>2</sup> or pascal
Standard atmosphere	101.325	Kilopascal (kPa)
Horsepower	550	Foot-pound/second
	745.7	Newton-meter/second or Watt
°F	$5/9(^{\circ}\text{F} - 32)$	°C
°C	$9/5(^{\circ}\text{C} + 32)$	°F
Log to base $e$ (i.e., $\log_e$ , where $e = 2.718$ )	0.434	Log to base 10 (i.e., $\log_{10}$ )

**TABLE A.2**  
**Geometric Properties of Common Shapes**



*Rectangle:*

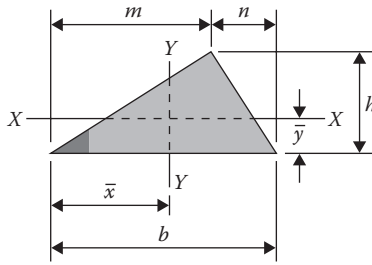
$$A = bh,$$

$$I_x = \frac{1}{12} bh^3,$$

$$r_x = \sqrt{\frac{I_x}{A}} = 0.288h.$$

(Continued)

**TABLE A.2 (Continued)**  
**Geometric Properties of Common Shapes**



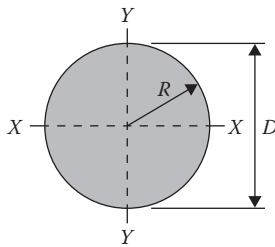
*Triangle:*

$$A = \frac{1}{2} bh,$$

$$\bar{y} = \frac{h}{3},$$

$$\bar{x} = \frac{b+m}{3},$$

$$I_x = \frac{1}{36} bh^3.$$



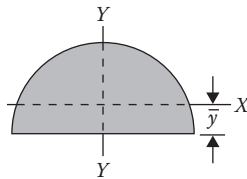
*Circle:*

$$A = \frac{1}{4} \pi D^2 = \pi R^2,$$

$$I_x = \frac{\pi D^4}{64} = \frac{\pi R^4}{4},$$

$$r_x = \sqrt{\frac{I_x}{A}} = \frac{D}{4} = \frac{R}{2},$$

$$J = I_x + I_y = \frac{\pi D^4}{32} = \frac{\pi R^4}{2}.$$



*Semicircle:*

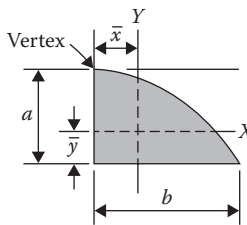
$$A = \frac{1}{8} \pi D^2 = \frac{1}{2} \pi R^2,$$

$$\bar{y} = \frac{4r}{3\pi},$$

$$I_x = 0.00682D^4 = 0.11R^4,$$

$$I_y = \frac{\pi D^4}{128} = \frac{\pi R^4}{8},$$

$$r_x = 0.264R.$$

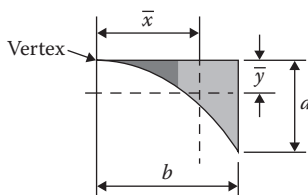


*Parabola:*

$$A = \frac{2}{3} ab,$$

$$\bar{x} = \frac{3}{8} b,$$

$$\bar{y} = \frac{2}{5} a.$$



*Spandrel of parabola:*

$$A = \frac{1}{3} ab,$$

$$\bar{x} = \frac{3}{4} b,$$

$$\bar{y} = \frac{3}{10} a.$$

**TABLE A.3**  
Shears, Moments, and Deflections

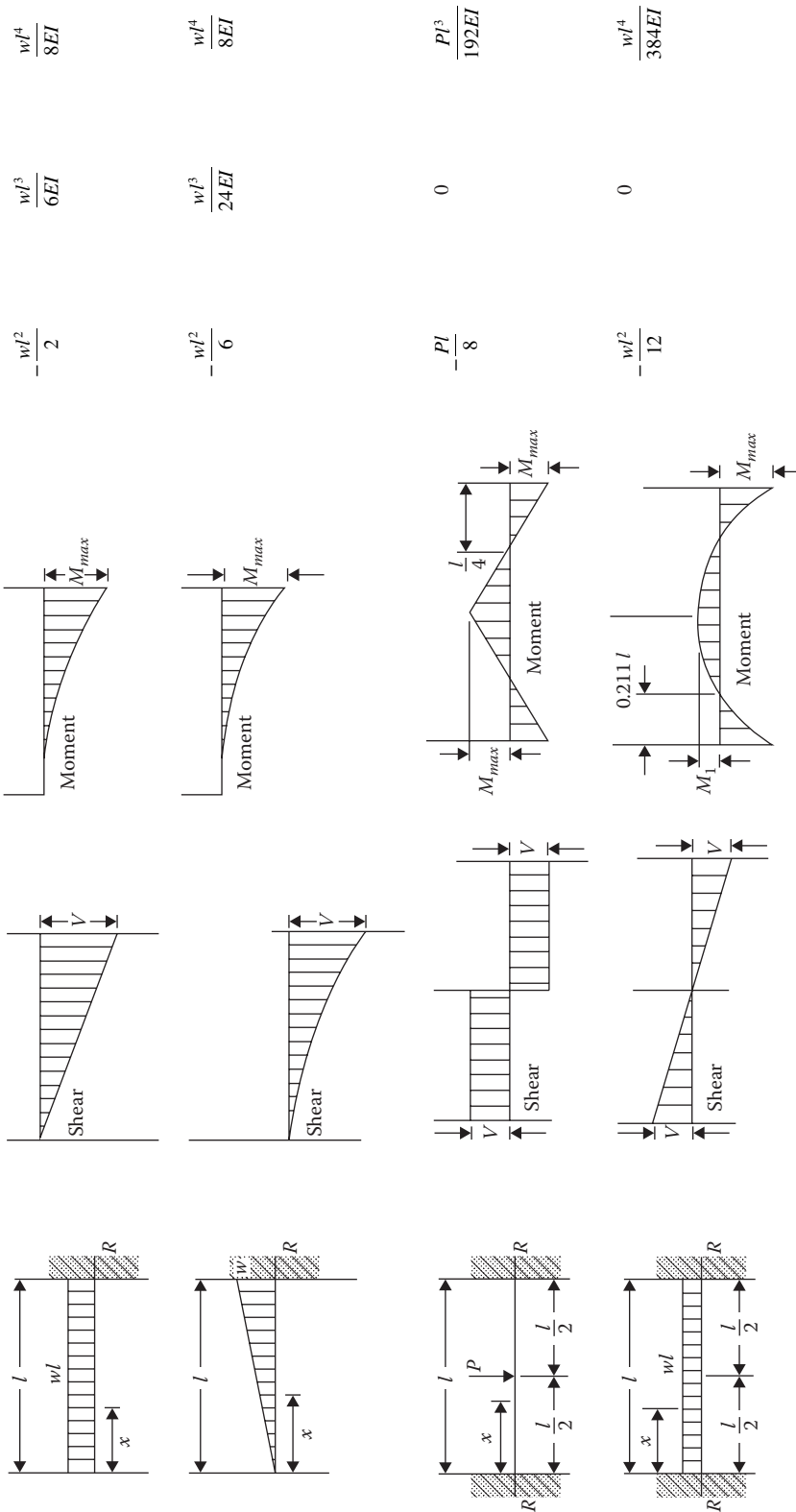
Loading	Shear Force Diagram	Moment Diagram	Maximum Moment	Slope at End	Maximum Deflection
			$\frac{Pl}{4}$	$\frac{Pl^2}{16EI}$	$\frac{Pl^3}{48EI}$
			$\frac{Pab}{l}$ at $x = a$	$\frac{Pa(l^2 - a^2)}{6EI}$ at $R_2$	$\frac{Pb(l^2 - b^2)^{3/2}}{9\sqrt{3}EI}$ at $x = \sqrt{\frac{l^2 - b^2}{3}}$
			$Pa$	$\frac{Pa(l - a)}{2EI}$	$\frac{Pa(3l^2 - 4a^2)}{24EI}$
			$\frac{wl^2}{8}$	$\frac{wl^3}{24EI}$	$\frac{5wl^4}{384EI}$

(Continued)

**TABLE A.3 (Continued)**  
Shears, Moments, and Deflections

Diagram	Maximum Moment	Slope at End	Maximum Deflection
	$\frac{wl^2}{9\sqrt{3}}$	$\frac{8wl^3}{360EI}$ at $R_2$	$\frac{2.5wl^4}{384EI}$ at $x = 0.519l$
	$\frac{wl^2}{12}$	$\frac{5wl^3}{192EI}$	$\frac{wl^4}{120EI}$
	$-Pl$	$\frac{Pl^2}{2EI}$	$\frac{Pl^3}{3EI}$
	$-Pb$	$\frac{Pl^2}{2EI}$	$\frac{Pb^2(3l-b)}{6EI}$ at free end





Note: w, load per unit length; W, total load.

**TABLE A.4**  
**Typical Properties of Engineering Materials**

Material	Strength (psi) (Yield Values Except Where Noted)			Modulus of Elasticity ( $E$ ) (ksi)	Coefficient of Thermal Expansion ( $F^{-1}$ ) ( $10^{-6}$ )
	Tension	Compression	Shear		
Wood (dry)					
Douglas fir	6,000	3,500 <sup>a</sup>	500	1,500	2
Redwood	6,500	4,500 <sup>a</sup>	450	1,300	2
Southern Pine	8,500	5,000 <sup>a</sup>	600	1,500	3
Steel	50,000	50,000	30,000	29,000	6.5
Concrete					
Structural, lightweight	150 <sup>b</sup>	3,500 <sup>b</sup>	130 <sup>b</sup>	2,100	5.5
Brick masonry	300 <sup>b</sup>	4,500 <sup>b</sup>	300 <sup>b</sup>	4,500	3.4
Aluminum, structural	30,000	30,000	18,000	10,000	12.8
Iron, cast	20,000 <sup>b</sup>	85,000 <sup>b</sup>	25,000 <sup>b</sup>	25,000	6
Glass, plate	10,000 <sup>b</sup>	36,000 <sup>b</sup>	—	10,000	4.5
Polyester, glass-reinforced	10,000 <sup>b</sup>	25,000 <sup>b</sup>	25,000 <sup>b</sup>	1,000	35

<sup>a</sup> For the parallel-to-grain direction.

<sup>b</sup> Denotes ultimate strength for brittle materials.

---

# Appendix B: Wood

**TABLE B.1**  
**Section Properties of Standard Dressed (S4S) Sawn Lumber**

Nominal Size ( <i>b</i> × <i>d</i> )	Standard Dressed Size (S4S) ( <i>b</i> × <i>d</i> ) (in. × in.)	x-x Axis		y-y Axis		Approximate Weight in Pounds per Linear Foot (lb./ft.) of Piece When Density of Wood Equals					
		Section Modulus <i>S<sub>xx</sub></i> (in. <sup>3</sup> )	Moment of Inertia <i>I<sub>xx</sub></i> (in. <sup>4</sup> )	Section Modulus <i>S<sub>yy</sub></i> (in. <sup>3</sup> )	Moment of Inertia <i>I<sub>yy</sub></i> (in. <sup>4</sup> )	35 lbs/ft <sup>3</sup>	40 lbs/ft <sup>3</sup>	45 lbs/ft <sup>3</sup>	50 lbs/ft <sup>3</sup>		
1 × 3	3/4 × 2 1/2	0.781	0.977	0.234	0.088	0.326	0.391	0.456	0.521	0.586	0.651
1 × 4	3/4 × 3 1/2	1.531	2.680	0.328	0.123	0.456	0.547	0.638	0.729	0.820	0.911
1 × 6	3/4 × 5 1/2	3.781	10.40	0.516	0.193	0.716	0.859	1.003	1.146	1.289	1.432
1 × 8	3/4 × 7 1/4	6.570	23.82	0.680	0.255	0.944	1.133	1.322	1.510	1.699	1.888
1 × 10	3/4 × 9 1/4	10.70	49.47	0.867	0.325	1.204	1.445	1.686	1.927	2.168	2.409
1 × 12	3/4 × 11 1/4	15.82	88.99	1.055	0.396	1.465	1.758	2.051	2.344	2.637	2.930
<b>Boards</b>											
<b>Dimension Lumber (see NDS 4.1.3.2) and Decking (see NDS 4.1.3.5)</b>											
2 × 3	1 1/2 × 2 1/2	1.56	1.953	0.938	0.703	0.651	0.781	0.911	1.042	1.172	1.302
2 × 4	1 1/2 × 3 1/2	3.06	5.359	1.313	0.984	0.911	1.094	1.276	1.458	1.641	1.823
2 × 5	1 1/2 × 4 1/2	5.06	11.39	1.688	1.266	1.172	1.406	1.641	1.875	2.109	2.344
2 × 6	1 1/2 × 5 1/2	7.56	20.80	2.063	1.547	1.432	1.719	2.005	2.292	2.578	2.865
2 × 8	1 1/2 × 7 1/4	13.14	47.63	2.719	2.039	1.888	2.266	2.643	3.021	3.398	3.776
2 × 10	1 1/2 × 9 1/4	21.39	98.93	3.469	2.602	2.409	2.891	3.372	3.854	4.336	4.818
2 × 12	1 1/2 × 11 1/4	31.64	178.0	4.219	3.164	2.930	3.516	4.102	4.688	5.273	5.859
2 × 14	1 1/2 × 13 1/4	43.89	290.8	4.969	3.727	3.451	4.141	4.831	5.521	6.211	6.901
3 × 4	2 1/2 × 3 1/2	5.10	8.932	3.646	4.557	1.519	1.823	2.127	2.431	2.734	3.038
3 × 5	2 1/2 × 4 1/2	8.44	18.98	4.688	5.859	1.953	2.344	2.734	3.125	3.516	3.906
3 × 6	2 1/2 × 5 1/2	12.60	34.66	5.729	7.161	2.387	2.865	3.342	3.819	4.297	4.774
3 × 8	2 1/2 × 7 1/4	21.90	79.39	7.552	9.440	3.147	3.776	4.405	5.035	5.664	6.293
3 × 10	2 1/2 × 9 1/4	35.65	164.9	9.635	12.04	4.015	4.818	5.621	6.424	7.227	8.030
3 × 12	2 1/2 × 11 1/4	52.73	296.6	11.72	14.65	4.883	5.859	6.836	7.813	8.789	9.766
3 × 14	2 1/2 × 13 1/4	73.15	484.6	13.80	17.25	5.751	6.901	8.051	9.201	10.35	11.50

3 × 16	2 1/2 × 15 1/4	38.13	96.90	738.9	15.89	19.86	6.619	7.943	9.266	10.59	11.91	13.24
4 × 4	3 1/2 × 3 1/2	12.25	7.15	12.51	7.146	12.51	2.127	2.552	2.977	3.403	3.828	4.253
4 × 5	3 1/2 × 4 1/2	15.75	11.81	26.58	9.188	16.08	2.734	3.281	3.828	4.375	4.922	5.469
4 × 6	3 1/2 × 5 1/2	19.25	17.65	48.53	11.23	19.65	3.342	4.010	4.679	5.347	6.016	6.684
4 × 8	3 1/2 × 7 1/4	25.38	30.66	111.1	14.80	25.90	4.405	5.286	6.168	7.049	7.930	8.811
4 × 10	3 1/2 × 9 1/4	32.38	49.91	230.8	18.89	33.05	5.621	6.745	7.869	8.993	10.12	11.24
4 × 12	3 1/2 × 11 1/4	39.38	73.83	415.3	22.97	40.20	6.836	8.203	9.570	10.94	12.30	13.67
4 × 14	3 1/2 × 13 1/4	46.38	102.41	678.5	27.05	47.34	8.051	9.661	11.27	12.88	14.49	16.10
4 × 16	3 1/2 × 15 1/4	53.38	135.66	1,034	31.14	54.49	9.266	11.12	12.97	14.83	16.68	18.53
<b>Timbers (5 in. × 5 in. and larger)</b>												
<b>Post and Timber (see NDS 4.1.3.4)</b>												
5 × 5	4 1/2 × 4 1/2	20.25	15.19	34.17	15.19	34.17	3.516	4.219	4.922	5.625	6.328	7.031
6 × 6	5 1/2 × 5 1/2	30.25	27.73	76.26	27.73	76.26	5.252	6.302	7.352	8.403	9.453	10.50
6 × 8	5 1/2 × 7 1/4	39.88	48.18	174.7	36.55	100.5	6.923	8.307	9.69	11.08	12.46	13.85
8 × 8	7 1/4 × 7 1/4	52.56	63.51	230.2	63.51	230.2	9.125	10.95	12.78	14.60	16.43	18.25
8 × 10	7 1/4 × 9 1/4	67.06	103.4	478.2	81.03	293.7	11.64	13.97	16.30	18.63	20.96	23.29
10 × 10	9 1/4 × 9 1/4	85.56	131.9	610.1	131.9	610.1	14.85	17.83	20.80	23.77	26.74	29.71
10 × 12	9 1/4 × 11 1/4	104.1	195.1	1,098	160.4	742.0	18.07	21.68	25.29	28.91	32.52	36.13
12 × 12	11 1/4 × 11 1/4	126.6	237.3	1,335	237.3	1,335	21.97	26.37	30.76	35.16	39.55	43.95
12 × 14	11 1/4 × 13 1/4	149.1	329.2	2,181	279.5	1,572	25.68	31.05	36.23	41.41	46.58	51.76
14 × 14	13 1/4 × 13 1/4	175.6	387.7	2,569	387.7	2,569	30.48	36.58	42.67	48.77	54.86	60.96
14 × 16	13 1/4 × 15	198.8	496.9	3,727	438.9	2,908	34.51	41.41	48.31	55.21	62.11	69.01
16 × 16	15 × 15	225.0	562.5	4,219	562.5	4,219	39.06	46.88	54.69	62.50	70.31	78.13
16 × 18	15 × 17	255.0	722.5	6,141	637.5	4,781	44.27	53.13	61.98	70.83	79.69	88.54
18 × 18	17 × 17	289.0	818.8	6,960	818.8	6,960	50.17	60.21	70.24	80.28	90.31	100.3
18 × 20	17 × 19	323.0	1,023	9,717	915.2	7,779	56.08	67.29	78.51	89.72	100.9	112.2
20 × 20	19 × 19	361.0	1,143	10,860	1,143	10,860	62.67	75.21	87.7	100.3	112.8	125.3
20 × 22	19 × 21	399.0	1,397	14,663	1,264	12,003	69.27	83.13	97.0	110.8	124.7	138.5
22 × 22	21 × 21	441.0	1,544	16,207	1,544	16,207	76.56	91.88	107.2	122.5	137.8	153.1
22 × 24	21 × 23	483.0	1,852	21,292	1,691	17,750	83.85	100.6	117.4	134.2	150.9	167.7
24 × 24	23 × 23	529.0	2,028	23,320	2,028	23,320	91.84	110.2	128.6	146.9	165.3	183.7

(Continued)

**TABLE B.1 (Continued)**  
**Section Properties of Standard Dressed (S4S) Sawn Lumber**

Nominal Size ( <i>b</i> × <i>d</i> )	Standard Dressed Size (S4S) ( <i>b</i> × <i>d</i> ) (in. × in.)	x-x Axis			y-y Axis			Approximate Weight in Pounds per Linear Foot (lb./ft.) of Piece When Density of Wood Equals					
		Area of Section A (in. <sup>2</sup> )	Section Modulus S <sub>xx</sub> (in. <sup>3</sup> )	Moment of Inertia I <sub>xx</sub> (in. <sup>4</sup> )	Section Modulus S <sub>yy</sub> (in. <sup>3</sup> )	Moment of Inertia I <sub>yy</sub> (in. <sup>4</sup> )	25 lbs/ft <sup>3</sup>	30 lbs/ft <sup>3</sup>	35 lbs/ft <sup>3</sup>	40 lbs/ft <sup>3</sup>	45 lbs/ft <sup>3</sup>	50 lbs/ft <sup>3</sup>	
<b>Beams and Stringers (see NDS 4.1.3.3)</b>													
6 × 10	5 1/2 × 9 1/4	50.88	78	363	47	128	8.83	10.6	12.4	14.1	15.9	17.7	
6 × 12	5 1/2 × 11 1/4	61.88	116.0	653	56.72	156.0	10.74	12.89	15.04	17.19	19.34	21.48	
6 × 14	5 1/2 × 13 1/4	72.88	160.9	1,066	66.80	183.7	12.65	15.18	17.71	20.24	22.77	25.30	
6 × 16	5 1/2 × 15	82.50	206.3	1,547	75.63	208.0	14.32	17.19	20.05	22.92	25.78	28.65	
6 × 18	5 1/2 × 17	93.50	264.9	2,252	85.71	235.7	16.23	19.48	22.73	25.97	29.22	32.47	
6 × 20	5 1/2 × 19	104.5	330.9	3,144	95.79	263.4	18.14	21.77	25.40	29.03	32.66	36.28	
6 × 22	5 1/2 × 21	115.5	404.3	4,245	105.9	291.2	20.05	24.06	28.07	32.08	36.09	40.10	
6 × 24	5 1/2 × 23	126.5	484.9	5,577	116.0	318.9	21.96	26.35	30.75	35.14	39.53	43.92	
8 × 12	7 1/2 × 11 1/4	81.6	152.9	860.2	98.6	357.3	14.16	16.99	19.82	22.66	25.49	28.32	
8 × 14	7 1/4 × 13 1/4	96.1	212.1	1,405	116.1	420.8	16.68	20.01	23.35	26.68	30.02	33.36	
8 × 16	7 1/4 × 15	108.8	271.9	2,039	131.4	476.3	18.88	22.66	26.43	30.21	33.98	37.76	
8 × 18	7 1/4 × 17	123.3	349.2	2,968	148.9	539.9	21.40	25.68	29.96	34.24	38.52	42.80	
8 × 20	7 1/4 × 19	137.8	436.2	4,144	166.4	603.4	23.91	28.70	33.48	38.26	43.05	47.83	
8 × 22	7 1/4 × 21	152.3	532.9	5,595	184.0	666.9	26.43	31.72	37.01	42.29	47.58	52.86	
8 × 24	7 1/4 × 23	166.8	639.2	7,351	201.5	730.4	28.95	34.74	40.53	46.32	52.11	57.90	
10 × 14	9 1/4 × 13 1/4	122.6	270.7	1,793	189.0	873.9	21.28	25.53	29.79	34.05	38.30	42.56	
10 × 16	9 1/4 × 15	138.8	346.9	2,602	213.9	989	24.09	28.91	33.72	38.54	43.36	48.18	
10 × 18	9 1/4 × 17	157.3	445.5	3,787	242.4	1,121	27.30	32.76	38.22	43.68	49.14	54.60	
10 × 20	9 1/4 × 19	175.8	556.5	5,287	270.9	1,253	30.51	36.61	42.72	48.82	54.92	61.02	
10 × 22	9 1/4 × 21	194.3	679.9	7,139	299.5	1,385	33.72	40.47	47.21	53.96	60.70	67.45	
10 × 24	9 1/4 × 23	212.8	815.5	9,379	328.0	1,517	36.94	44.32	51.71	59.10	66.48	73.87	
12 × 16	11 1/4 × 15	168.8	421.9	3,164	316.4	1,780	29.30	35.16	41.02	46.88	52.73	58.59	
12 × 18	11 1/4 × 17	191.3	541.9	4,606	358.6	2,017	33.20	39.84	46.48	53.13	59.77	66.41	

12 × 20	11 1/4 × 19	213.8	676.9	6,430	400.8	2,254	37.11	44.53	51.95	59.38	66.80	74.22
12 × 22	11 1/4 × 21	236.3	826.9	8,682	443.0	2,492	41.02	49.22	57.42	65.63	73.83	82.03
12 × 24	11 1/4 × 23	258.8	992	11,407	485.2	2,729	44.92	53.91	62.89	71.88	80.86	89.84
14 × 18	13 1/4 × 17	225.3	638.2	5,425	497.4	3,295	39.11	46.93	54.75	62.57	70.39	78.21
14 × 20	13 1/4 × 19	251.8	797.2	7,573	555.9	3,683	43.71	52.45	61.19	69.93	78.67	87.41
14 × 22	13 1/4 × 21	278.3	974	10,226	614.5	4,071	48.31	57.97	67.63	77.29	86.95	96.6
14 × 24	13 1/4 × 23	304.8	1,168	13,434	673.0	4,459	52.91	63.49	74.07	84.65	95.23	105.8
16 × 20	15 × 19	285.0	902.5	8,574	712.5	5,344	49.48	59.38	69.27	79.17	89.06	99.0
16 × 22	15 × 21	315.0	1,103	11,576	787.5	5,906	54.69	65.63	76.56	87.50	98.4	109.4
16 × 24	15 × 23	345.0	1,323	15,209	862.5	6,469	59.90	71.88	83.85	95.8	107.8	119.8
18 × 22	17 × 21	357.0	1,250	13,120	1,012	8,598	61.98	74.38	86.77	99.2	111.6	124.0
18 × 24	17 × 23	391.0	1,499	17,237	1,108	9,417	67.88	81.46	95.03	108.6	122.2	135.8
20 × 24	19 × 23	437.0	1,675	19,264	1,384	13,146	75.87	91.04	106.2	121.4	136.6	151.7

Source: Courtesy of the American Wood Council.

Note: NDS, National Design Specification.

**TABLE B.2**  
**Size Factor and Flat Use Factor (All Species except Southern Pine)**

**Flat Use Factor,  $C_{fu}$**

Bending design values adjusted by size factors are based on edgewise use (load applied to narrow face). When dimension lumber is used flatwise (load applied to wide face), the bending design value,  $F_b$ , shall also be multiplied by the following flat use factors:

Width (Depth)	Thickness (Breadth)	
	2 in. and 3 in.	4 in.
2 in. and 3 in.	1.0	—
4 in.	1.1	1.0
5 in.	1.1	1.05
6 in.	1.15	1.05
8 in.	1.15	1.05
10 in. and wider	1.2	1.1

**Size Factor,  $C_F$**

Tabulated bending, tension, and compression parallel to grain design values for dimension lumber 2 in.–4 in. thick shall be multiplied by the following size factors:

Grades	Width (Depth)	$F_b$		$F_t$	$F_c$
		2 in. and 3 in.	4 in.		
Select structural, No. 1 and Btr, No. 1, No. 2, No. 3	2 in., 3 in., and 4 in.	1.5	1.5	1.5	1.15
	5 in.	1.4	1.4	1.4	1.1
	6 in.	1.3	1.3	1.3	1.1
	8 in.	1.2	1.3	1.2	1.05
	10 in.	1.1	1.2	1.1	1.0
	12 in.	1.0	1.1	1.0	1.0
	14 in. and wider	0.9	1.0	0.9	0.9
Stud	2 in., 3 in., and 4 in.	1.1	1.1	1.1	1.05
	5 in. and 6 in.	1.0	1.0	1.0	1.0
	8 in. and wider	Use No. 3 Grade tabulated design values and size factors			
Construction, standard	2 in., 3 in., and 4 in.	1.0	1.0	1.0	1.0
Utility	4 in.	1.0	1.0	1.0	1.0
	2 in. and 3 in.	0.4	—	0.4	0.6



**TABLE B.2**  
**Reference Design Values for Visually Graded Dimension Lumber (2–4 in. Breadth) (All Species except Southern Pine)**

Species and Commercial Grade	Size Classification	Design Values in Pounds per Square Inch (psi)							Modulus of Elasticity		Grading Rules Agency
		Bending, $F_b$	Tension Parallel to Grain, $F_t$	Shear Parallel to Grain, $F_v$	Compression Perpendicular to Grain, $F_{c\perp}$	Compression Parallel to Grain, $F_c$	$E$	$E_{min}$			
<b>Beech-Birch-Hickory</b>											
Select structural	2 in. and wider	1,450	850	195	715	1,200	1,700,000	620,000	NELMA		
No. 1		1,050	600	195	715	950	1,600,000	580,000			
No. 2		1,000	600	195	715	750	1,500,000	550,000			
No. 3		575	350	195	715	425	1,300,000	470,000			
Stud	2 in. and wider	775	450	195	715	475	1,300,000	470,000			
Construction	2–4 in. wide	1,150	675	195	715	1,000	1,400,000	510,000			
Standard		650	375	195	715	775	1,300,000	470,000			
Utility		300	175	195	715	500	1,200,000	440,000			
<b>Cottonwood</b>											
Select structural	2 in. and wider	875	525	125	320	775	1,200,000	440,000	NSLB		
No. 1		625	375	125	320	625	1,200,000	440,000			
No. 2		625	350	125	320	475	1,100,000	400,000			
No. 3		350	200	125	320	275	1,000,000	370,000			
Stud	2 in. and wider	475	275	125	320	300	1,000,000	370,000			
Construction	2–4 in. wide	700	400	125	320	650	1,000,000	370,000			
Standard		400	225	125	320	500	900,000	330,000			
Utility		175	100	125	320	325	900,000	330,000			
<b>Douglas Fir-Larch</b>											
Select structural	2 in. and wider	1,500	1,000	180	625	1,700	1,900,000	690,000	WCLIB		
No. 1 and Btr		1,200	800	180	625	1,550	1,800,000	660,000	WWPA		

(Continued)

**TABLE B.2 (Continued)**  
**Reference Design Values for Visually Graded Dimension Lumber (2–4 in. Breadth) (All Species except Southern Pine)**

Species and Commercial Grade	Size Classification	Design Values in Pounds per Square Inch (psi)							Modulus of Elasticity		Grading Rules Agency
		Bending, $F_b$	Tension Parallel to Grain, $F_t$	Shear Parallel to Grain, $F_v$	Compression Perpendicular to Grain, $F_{c\perp}$	Compression Parallel to Grain, $F_c$	$E$	$E_{min}$			
No. 1		1,000	675	180	625	1,500	1,700,000	620,000			
No. 2		900	575	180	625	1,350	1,600,000	580,000			
No. 3		525	325	180	625	775	1,400,000	510,000			
Stud	2 in. and wider	700	450	180	625	850	1,400,000	510,000			
Construction	2–4 in. wide	1,000	650	180	625	1,650	1,500,000	550,000			
Standard		575	375	180	625	1,400	1,400,000	510,000			
Utility		275	175	180	625	900	1,300,000	470,000			
<b>Douglas Fir-Larch (North)</b>											
Select structural	2 in. and wider	1,350	825	180	625	1,900	1,900,000	690,000		NLGA	
No. 1 and Btr		1,150	750	180	625	1,800	1,800,000	660,000			
No. 1/No. 2		850	500	180	625	1,400	1,600,000	580,000			
No. 3		475	300	180	625	825	1,400,000	510,000			
Stud	2 in. and wider	650	400	180	625	900	1,400,000	510,000			
Construction	2–4 in. wide	950	575	180	625	1,800	1,500,000	550,000			
Standard		525	325	180	625	1,450	1,400,000	510,000			
Utility		250	150	180	625	950	1,300,000	470,000			
<b>Douglas Fir (South)</b>											
Select structural	2 in. and wider	1,350	900	180	520	1,600	1,400,000	510,000		WWPA	
No. 1		925	600	180	520	1,450	1,300,000	470,000			
No. 2		850	525	180	520	1,350	1,200,000	440,000			
No. 3		500	300	180	520	775	1,100,000	400,000			
Stud	2 in. and wider	675	425	180	520	850	1,100,000	400,000			
Construction	2–4 in. wide	975	600	180	520	1,650	1,200,000	440,000			

Standard	550	350	180	520	1,400	1,100,000	400,000
Utility	250	150	180	520	900	1,000,000	370,000
<b>Eastern Hemlock-Balsam Fir</b>							
Select structural	1,250	575	140	335	1,200	1,200,000	440,000
No. 1	775	350	140	335	1,000	1,100,000	400,000
No. 2	575	275	140	335	825	1,100,000	400,000
No. 3	350	150	140	335	475	900,000	330,000
Stud	450	200	140	335	525	900,000	330,000
Construction	675	300	140	335	1,050	1,000,000	370,000
Standard	375	175	140	335	850	900,000	330,000
Utility	175	75	140	335	550	800,000	290,000
<b>Eastern Hemlock-Tamarack</b>							
Select structural	1,250	575	170	555	1,200	1,200,000	440,000
No. 1	775	350	170	555	1,000	1,100,000	400,000
No. 2	575	275	170	555	825	1,100,000	400,000
No. 3	350	150	170	555	475	900,000	330,000
Stud	450	200	170	555	525	900,000	330,000
Construction	675	300	170	555	1,050	1,000,000	370,000
Standard	375	175	170	555	850	900,000	330,000
Utility	175	75	170	555	550	800,000	290,000
<b>Eastern Softwoods</b>							
Select structural	1,250	575	140	335	1,200	1,200,000	440,000
No. 1	775	350	140	335	1,000	1,100,000	400,000
No. 2	575	275	140	335	825	1,100,000	400,000
No. 3	350	150	140	335	475	900,000	330,000
Stud	450	200	140	335	525	900,000	330,000
Construction	675	300	140	335	1,050	1,000,000	370,000
Standard	375	175	140	335	850	900,000	330,000
Utility	175	75	140	335	550	800,000	290,000

(Continued)

**TABLE B.2 (Continued)**  
**Reference Design Values for Visually Graded Dimension Lumber (2–4 in. Breadth) (All Species except Southern Pine)**

Species and Commercial Grade	Size Classification	Design Values in Pounds per Square Inch (psi)							Modulus of Elasticity		Grading Rules Agency
		Bending, $F_b$	Tension Parallel to Grain, $F_t$	Shear Parallel to Grain, $F_v$	Compression Perpendicular to Grain, $F_{c\perp}$	Compression Parallel to Grain, $F_c$	$E$	$E_{min}$			
<b>Eastern White Pine</b>											
Select structural	2 in. and wider	1,250	575	135	350	1,200	1,200,000	440,000	NELMA		
No. 1		775	350	135	350	1,000	1,100,000	400,000	NSLB		
No. 2		575	275	135	350	825	1,100,000	400,000			
No. 3		350	150	135	350	475	900,000	330,000			
Stud	2 in. and wider	450	200	135	350	525	900,000	330,000			
Construction	2–4 in. wide	675	300	135	350	1,050	1,000,000	370,000			
Standard		375	175	135	350	850	900,000	330,000			
Utility		175	75	135	350	550	800,000	290,000			
<b>Hem-Fir</b>											
Select structural	2 in. and wider	1,400	925	150	405	1,500	1,600,000	580,000	WCLIB		
No. 1 and Btr		1,100	725	150	405	1,350	1,500,000	550,000	WWPA		
No. 1		975	625	150	405	1,350	1,500,000	550,000			
No. 2		850	525	150	405	1,300	1,300,000	470,000			
No. 3		500	300	150	405	725	1,200,000	440,000			
Stud	2 in. and wider	675	400	150	405	800	1,200,000	440,000			
Construction	2–4 in. wide	975	600	150	405	1,550	1,300,000	470,000			
Standard		550	325	150	405	1,300	1,200,000	440,000			
Utility		250	150	150	405	850	1,100,000	400,000			
<b>Hem-Fir (North)</b>											
Select structural	2 in. and wider	1,300	775	145	405	1,700	1,700,000	620,000	NLGA		
No. 1 and Btr		1,200	725	145	405	1,550	1,700,000	620,000			
No. 1/No. 2		1,000	575	145	405	1,450	1,600,000	580,000			
No. 3		575	325	145	405	850	1,400,000	510,000			

Stud	2 in. and wider	775	450	145	405	925	1,400,000	510,000
Construction	2-4 in. wide	1,150	650	145	405	1,750	1,500,000	550,000
Standard		650	350	145	405	1,500	1,400,000	510,000
Utility		300	175	145	405	975	1,300,000	470,000
Select structural		1,000	600	<b>Mixed Maple</b>				
No. 1	2 in. and wider	725	425	195	620	875	1,300,000	470,000
No. 2		700	425	195	620	700	1,200,000	440,000
No. 3		400	250	195	620	550	1,100,000	400,000
Stud	2 in. and wider	550	325	195	620	325	1,000,000	370,000
Construction	2-4 in. wide	800	475	195	620	350	1,000,000	370,000
Standard		450	275	195	620	725	1,100,000	400,000
Utility		225	125	195	620	575	1,000,000	370,000
						375	900,000	330,000

Source: Courtesy of the American Forest & Paper Association, Washington, DC.

Notes: Tabulated design values are for normal load duration and dry service conditions. See NDS 4.3 for a comprehensive description of design value adjustment factors.

**TABLE B.3**  
**Size Factor and Flat Use Factor for Southern Pine**

**Flat Use Factor,  $C_{fu}$**

Bending design values adjusted by size factors are based on edgewise use (load applied to narrow face). When dimension lumber is used flatwise (load applied to wide face), the bending design value,  $F_b$ , shall also be multiplied by the following flat use factors:

Width (depth)	Thickness (breadth)	
	2 in. and 3 in.	4 in.
2 in. and 3 in.	1.0	—
4 in.	1.1	1.0
5 in.	1.1	1.05
6 in.	1.15	1.05
8 in.	1.15	1.05
10 in. and wider	1.2	1.1

**Size Factor,  $C_F$**

Appropriate size adjustment factors have already been included in the tabular design values of Southern Pine and mixed Southern Pine dimension lumber, except the following cases:

Grade	Size	$F_b$	$F_c$	$F_t$	$F_v, F_{c\perp}, E, E_{min}$
All grades (except Dense Structural 86, Dense Structural 72, Dense Structural 65)	(1) For 4-in. breadth $\times$ 8 in. or more depth	1.1			
	(2) For all dimension lumber >12-in. depth, the table values of 12-in. depth multiplied as shown across	0.9	0.9	0.9	1.00
Dense Structural 86, Dense Structural 72, Dense Structural 65	For dimension lumber >12-in. depth, $F_b$ table value of 12 in. multiplied as shown across	$(12/d)^{1/9}$			

**TABLE B.3**  
**Reference Design Values for Visually Graded Southern Pine Dimension Lumber (2 in.-4 in. Thick)**

Species and Commercial Grade	Size Classification	Design Values in Pounds per Square Inch (psi)										Specific Gravity <i>G</i>	Grading Rules Agency
		Bending <i>F<sub>b</sub></i>	Tension Parallel to Grain <i>F<sub>t</sub></i>	Shear Parallel to Grain <i>F<sub>v</sub></i>	Compression		Modulus of Elasticity		Compression Parallel to Grain <i>F<sub>c</sub></i>	<i>E</i>	<i>E<sub>min</sub></i>		
					Perpendicular to Grain <i>F<sub>c⊥</sub></i>	Parallel to Grain <i>F<sub>c</sub></i>	<i>E</i>	<i>E<sub>min</sub></i>					
Southern Pine													
Dense select structural	2 in.-4 in. wide	3,050	1,650	175	660	2,250	1,900,000	690,000	0.55			SPIB	
Select structural		2,850	1,600	175	565	2,100	1,800,000	660,000					
Nondense select structural		2,650	1,350	175	480	1,950	1,700,000	620,000					
No. 1 Dense		2,000	1,100	175	660	2,000	1,800,000	660,000					
No. 1		1,850	1,050	175	565	1,850	1,700,000	620,000					
No. 1 Nondense		1,700	900	175	480	1,700	1,600,000	580,000					
No. 2 Dense		1,150	750	175	660	1,250	1,500,000	550,000					
No. 2		1,050	650	175	565	1,100	1,400,000	510,000					
No. 2 Nondense		975	575	175	480	1,050	1,200,000	440,000					
No. 3 and stud		600	375	175	565	625	1,200,000	440,000	0.55				
Construction	4 in. wide	800	500	175	565	1,150	1,300,000	470,000					
Standard		450	275	175	565	950	1,200,000	440,000					
Utility		200	125	175	565	625	1,100,000	400,000					
Dense select structural	5 in.-6 in. wide	2,700	1,500	175	660	2,150	1,900,000	690,000	0.55				
Select structural		2,550	1,400	175	565	2,000	1,800,000	660,000					
Nondense select structural		2,350	1,200	175	480	1,850	1,700,000	620,000					
No. 1 Dense		1,750	950	175	660	1,900	1,800,000	660,000					
No. 1		1,650	900	175	565	1,750	1,700,000	620,000					
No. 1 Nondense		1,500	800	175	480	1,600	1,600,000	580,000					
No. 2 Dense		1,450	775	175	660	1,750	1,700,000	620,000					
No. 2		1,250	725	175	565	1,600	1,600,000	580,000					
No. 2 Nondense		1,150	675	175	480	1,500	1,400,000	510,000					

(Continued)

**TABLE B.3 (Continued)**  
**Reference Design Values for Visually Graded Southern Pine Dimension Lumber (2 in.-4 in. Thick)**

Species and Commercial Grade	Size Classification	Design Values in Pounds per Square Inch (psi)										Specific Gravity $G$	Grading Rules Agency
		Bending $F_b$	Tension Parallel to Grain $F_t$	Shear Parallel to Grain $F_v$	Compression Perpendicular to Grain $F_{c\perp}$	Compression Parallel to Grain $F_{c\parallel}$	Modulus of Elasticity		Specific Gravity $G$	Grading Rules Agency			
							$E$	$E_{min}$					
<b>Southern Pine</b>													
No. 3 and stud		750	425	175	565	925	1,400,000	510,000					
Dense select structural	8 in. wide	2,450	1,350	175	660	2,050	1,900,000	690,000			0.55		
Select structural		2,300	1,300	175	565	1,900	1,800,000	660,000					
Non-dense select structural		2,100	1,100	175	480	1,750	1,700,000	620,000					
No. 1 Dense		1,650	875	175	660	1,800	1,800,000	660,000					
No. 1		1,500	825	175	565	1,650	1,700,000	620,000					
No. 1 Non-dense		1,350	725	175	480	1,550	1,600,000	580,000					
No. 2 Dense		1,400	675	175	660	1,700	1,700,000	620,000					
No. 2		1,200	650	175	565	1,550	1,600,000	580,000					
No. 2 Nondense		1,100	600	175	480	1,450	1,400,000	510,000					
No. 3 and stud		700	400	175	565	875	1,400,000	510,000					
Dense select structural	10 in. wide	2,150	1,200	175	660	2,000	1,900,000	690,000			0.55		
Select structural		2,050	1,100	175	565	1,850	1,800,000	660,000					
Nondense select structural		1,850	950	175	480	1,750	1,700,000	620,000					
No. 1 Dense		1,450	775	175	660	1,750	1,800,000	660,000					
No. 1		1,300	725	175	565	1,600	1,700,000	620,000					
No. 1 Nondense		1,200	650	175	480	1,500	1,600,000	580,000					
No. 2 Dense		1,200	625	175	660	1,650	1,700,000	620,000					
No. 2		1,050	575	175	565	1,500	1,600,000	580,000					
No. 2 Nondense		950	550	175	480	1,400	1,400,000	510,000					
No. 3 and stud		600	325	175	565	850	1,400,000	510,000					



Dense select structural	12 in. wide	2,050	1,100	175	660	1,950	1,900,000	690,000	0.55
Select structural		1,900	1,050	175	565	1,800	1,800,000	660,000	
Nondense select structural		1,750	900	175	480	1,700	1,700,000	620,000	
No. 1 Dense		1,350	725	175	660	1,700	1,800,000	660,000	
No. 1		1,250	675	175	565	1,600	1,700,000	620,000	
No. 1 Nondense		1,150	600	175	480	1,500	1,600,000	580,000	
No. 2 Dense		1,150	575	175	660	1,600	1,700,000	620,000	
No. 2		975	550	175	565	1,450	1,600,000	580,000	
No. 2 Nondense		900	525	175	480	1,350	1,400,000	510,000	
No. 3 and stud		575	325	175	565	825	1,400,000	510,000	
<b>Southern Pine (Surfaced Dry – Used in dry service conditions – 19% or less moisture content)</b>									
Dense structural 86	2 in. and wider	2,600	1,750	175	660	2,000	1,800,000	660,000	0.55
Dense structural 72		2,200	1,450	175	660	1,650	1,800,000	660,000	
Dense structural 65		2,000	1,300	175	660	1,500	1,800,000	660,000	
<b>Southern Pine (Surfaced Green – Used in any service condition)</b>									
Dense structural 86	2-1/2 in. and wider	2,100	1,400	165	440	1,300	1,600,000	580,000	0.55
Dense structural 72		1,750	1,200	165	440	1,100	1,600,000	580,000	
Dense structural 65	2-1/2 in.–4 in. thick	1,600	1,050	165	440	1,000	1,600,000	580,000	
<b>Mixed Southern Pine</b>									
Select structural	2 in.–4 in. wide	2,050	1,200	175	565	1,800	1,600,000	580,000	0.51
No. 1		1,450	875	175	565	1,650	1,500,000	550,000	
No. 2		1,050	650	175	565	1,100	1,400,000	510,000	
No. 3 and stud		600	375	175	565	625	1,200,000	440,000	
Construction	4 in. wide	800	500	175	565	1,150	1,300,000	470,000	0.51
Standard		450	275	175	565	950	1,200,000	440,000	
Utility		200	125	175	565	625	1,100,000	400,000	
Select structural	5 in.–6 in. wide	1,850	1,100	175	565	1,700	1,600,000	580,000	
No. 1		1,300	750	175	565	1,550	1,500,000	550,000	
No. 2		1,150	675	175	565	1,550	1,400,000	510,000	
No. 3 and stud		675	400	175	565	875	1,200,000	440,000	

(Continued)

**TABLE B.3 (Continued)**  
**Reference Design Values for Visually Graded Southern Pine Dimension Lumber (2 in.-4 in. Thick)**

Species and Commercial Grade	Size Classification	Design Values in Pounds per Square Inch (psi)							Modulus of Elasticity		Specific Gravity $G$	Grading Rules Agency
		Bending $F_b$	Tension Parallel to Grain $F_t$	Shear Parallel to Grain $F_v$	Compression Perpendicular to Grain $F_{c\perp}$	Compression Parallel to Grain $F_c$	$E$	$E_{min}$	Modulus of Elasticity			
									Conversion Factors for Determining Design Values for Spruce Pine			
<b>Mixed Southern Pine</b>												
Select structural	8 in. wide	1,750	1,000	175	565	1,600	1,600,000	580,000	0.51			
No. 1		1,200	700	175	565	1,450	1,500,000	550,000				
No. 2		1,050	625	175	565	1,450	1,400,000	510,000				
No. 3 and stud		625	375	175	565	850	1,200,000	440,000				
Select structural	10 in. wide	1,500	875	175	565	1,600	1,600,000	580,000	0.51			
No. 1		1,050	600	175	565	1,450	1,500,000	550,000				
No. 2		925	550	175	565	1,450	1,400,000	510,000				
No. 3 and stud		525	325	175	565	825	1,200,000	440,000				
Select structural	12 in. wide	1,400	825	175	565	1,550	1,600,000	580,000	0.51			
No. 1		975	575	175	565	1,400	1,500,000	550,000				
No. 2		875	525	175	565	1,400	1,400,000	510,000				
No. 3 and stud		500	300	175	565	800	1,200,000	440,000				

**Spruce Pine**

To obtain recommended design values for Spruce Pine graded to SPIB rules, multiply the appropriate design values for Mixed Southern Pine by the corresponding conversion factor shown below. Round off the values to the nearest 100,000 psi for  $E$ ; to the nearest 10,000 psi for  $E_{min}$ ; to the next lower multiple of 5 psi for  $F_v$  and  $F_{c\perp}$ ; and to the next lower multiple of 50 psi for  $F_b$ ,  $F_t$ , and  $F_c$  if the value is 1,000 psi or greater, 25 psi otherwise

Conversion Factors for Determining Design Values for Spruce Pine				
Bending $F_b$	Tension Parallel to Grain $F_t$	Shear Parallel to Grain $F_v$	Compression Perpendicular to Grain $F_{c\perp}$	Compression Parallel to Grain $F_c$
0.78	0.78	0.98	0.73	0.78
Conversion factor				Modulus of Elasticity $E$ and $E_{min}$
				0.82

**TABLE B.4**  
**Size Factor and Flat Use Factor for Timbers**

**Size Factor,  $C_F$**

When visually graded timbers are subjected to loads applied to the narrow face, tabulated design values shall be multiplied by the following size factors:

Depth	$F_b$	$F_t$	$F_c$
$d > 12$ in.	$(12/d)^{1/9}$	1.0	1.0
$d \leq 12$ in.	1.0	1.0	1.0

**Flat Use Factor,  $C_{fu}$**

When members designated as Beams and Stringers in Table B.4 are subjected to loads applied to the wide face, tabulated design values shall be multiplied by the following flat use factors:

Grade	$F_b$	$E$ and $E_{\min}$	Other Properties
Select structural	0.86	1.00	1.00
No. 1	0.74	0.90	1.00
No. 2	1.00	1.00	1.00

**TABLE B.4**  
**Reference Design Values for Visually Graded Timbers (5 in. × 5 in. and Larger)**

Species and Commercial Grade	Size Classification	Design Values in Pounds per Square Inch (psi)										Specific Gravity <i>G</i>	Grading Rules Agency
		Bending $F_b$	Tension Parallel to Grain $F_t$	Shear Parallel to Grain $F_v$	Compression Perpendicular to Grain $F_{c\perp}$	Compression Parallel to Grain $F_c$	Modulus of Elasticity		Specific Gravity <i>G</i>	Grading Rules Agency			
							$E$	$E_{min}$					
<b>Beech-Birch-Hickory</b>													
Select structural	Beams and stringers	1,650	975	180	715	975	1,500,000	550,000	0.71	NELMA			
No. 1		1,400	700	180	715	825	1,500,000	550,000		NSLB			
No. 2		900	450	180	715	525	1,200,000	440,000					
Select structural	Posts and timbers	1,550	1,050	180	715	1,050	1,500,000	550,000					
No. 1		1,250	850	180	715	900	1,500,000	550,000					
No. 2		725	475	180	715	425	1,200,000	440,000					
<b>Coast Sitka Spruce</b>													
Select structural	Beams and stringers	1,150	675	115	455	775	1,500,000	550,000	0.43	NLGA			
No. 1		950	475	115	455	650	1,500,000	550,000					
No. 2		625	325	115	455	425	1,200,000	440,000					
Select structural	Posts and timbers	1,100	725	115	455	825	1,500,000	550,000					
No. 1		875	575	115	455	725	1,500,000	550,000					
No. 2		525	350	115	455	500	1,200,000	440,000					
<b>Douglas Fir-Larch</b>													
Dense select structural	Beams and stringers	1,900	1,100	170	730	1,300	1,700,000	620,000	0.50	WWPA			
Select structural		1,600	950	170	625	1,100	1,600,000	580,000					
Dense No. 1		1,550	775	170	730	1,100	1,700,000	620,000					
No. 1		1,350	675	170	625	925	1,600,000	580,000					
No. 2 Dense		1,000	500	170	730	700	1,400,000	510,000					
No. 2		875	425	170	625	600	1,300,000	470,000					
Dense select structural	Posts and timbers	1,750	1,150	170	730	1,350	1,700,000	620,000					
Select structural		1,500	1,000	170	625	1,150	1,600,000	580,000					

Dense No. 1		1,400	950	170	730	1,200	1,700,000	620,000	
No. 1		1,200	825	170	625	1,000	1,600,000	580,000	
No. 2 Dense		850	550	170	730	825	1,400,000	510,000	
No. 2		750	475	170	625	700	1,300,000	470,000	
<b>Douglas Fir-Larch (North)</b>									
Select structural	Beams and stringers	1,600	950	170	625	1,100	1,600,000	580,000	0.49
No. 1		1,300	675	170	625	925	1,600,000	580,000	
No. 2		875	425	170	625	600	1,300,000	470,000	
Select structural	Posts and timbers	1,500	1,000	170	625	1,150	1,600,000	580,000	
No. 1		1,200	825	170	625	1,000	1,600,000	580,000	
No. 2		725	475	170	625	700	1,300,000	470,000	
<b>Douglas Fir-South</b>									
Select structural	Beams and stringers	1,550	900	165	520	1,000	1,200,000	440,000	0.46
No. 1		1,300	625	165	520	850	1,200,000	440,000	
No. 2		825	425	165	520	550	1,000,000	370,000	
Select structural	Posts and timbers	1,450	950	165	520	1,050	1,200,000	440,000	
No. 1		1,150	775	165	520	925	1,200,000	440,000	
No. 2		675	450	165	520	650	1,000,000	370,000	
<b>Eastern Hemlock</b>									
Select structural	Beams and stringers	1,350	925	155	550	950	1,200,000	440,000	0.41
No. 1		1,150	775	155	550	800	1,200,000	440,000	
No. 2		750	375	155	550	550	900,000	330,000	
Select structural	Posts and timbers	1,250	850	155	550	1,000	1,200,000	440,000	
No. 1		1,050	700	155	500	875	1,200,000	440,000	
No. 2		600	400	155	550	400	900,000	330,000	
<b>Eastern Hemlock-Tamarack</b>									
Select structural	Beams and stringers	1,400	925	155	555	950	1,200,000	440,000	0.41
No. 1		1,150	775	155	555	800	1,200,000	440,000	
No. 2		750	375	155	555	500	900,000	330,000	
Select structural	Posts and timbers	1,300	875	155	555	1,000	1,200,000	440,000	
No. 1		1,050	700	155	555	875	1,200,000	440,000	
No. 2		600	400	155	555	400	900,000	330,000	

(Continued)

**TABLE B.4 (Continued)**  
**Reference Design Values for Visually Graded Timbers (5 in. × 5 in. and Larger)**

Species and Commercial Grade	Size Classification	Design Values in Pounds per Square Inch (psi)										Specific Gravity <i>G</i>	Grading Rules Agency
		Bending $F_b$	Tension Parallel to Grain $F_t$	Shear Parallel to Grain $F_v$	Compression Perpendicular to Grain $F_{c\perp}$	Compression Parallel to Grain $F_c$	Modulus of Elasticity		Specific Gravity <i>G</i>	Grading Rules Agency			
							$E$	$E_{min}$					
<b>Eastern Spruce</b>													
Select structural No. 1	Beams and stringers	1,050	725	135	390	750	1,400,000	510,000	0.41	NELMA			
Select structural No. 2	Posts and timbers	900	600	135	390	625	1,400,000	510,000		NSLB			
Select structural No. 1		575	275	135	390	375	1,000,000	370,000					
Select structural No. 1		1,000	675	135	390	775	1,400,000	510,000					
Select structural No. 2		800	550	135	390	675	1,400,000	510,000					
Select structural No. 2		450	300	135	390	300	1,000,000	370,000					
<b>Eastern White Pine</b>													
Select structural No. 1	Beams and stringers	1,050	700	125	350	675	1,100,000	400,000	0.36	NELMA			
Select structural No. 2		875	600	125	350	575	1,100,000	400,000		NSLB			
Select structural No. 1		575	275	125	350	400	900,000	330,000					
Select structural No. 1		975	650	125	350	725	1,100,000	400,000					
Select structural No. 2		800	525	125	350	625	1,100,000	400,000					
Select structural No. 2		450	300	125	350	325	900,000	330,000					
<b>Hem-Fir</b>													
Select structural No. 1	Beams and stringers	1,300	750	140	405	925	1,300,000	470,000	0.43	WCLJB WWPA			
Select structural No. 2		1,050	525	140	405	750	1,300,000	470,000					
Select structural No. 1		675	350	140	405	500	1,100,000	400,000					
Select structural No. 1		1,200	800	140	405	975	1,300,000	470,000					
Select structural No. 2		975	650	140	405	850	1,300,000	470,000					
Select structural No. 2		575	375	140	405	575	1,100,000	400,000					

		Hem-Fir (North)								
Select structural	Beams and stringers	1,250	725	135	405	900	1,300,000	470,000	0.46	NLGA
No. 1		1,000	500	135	405	750	1,300,000	470,000		
No. 2		675	325	135	405	475	1,100,000	400,000		
Select structural	Posts and timbers	1,150	775	135	405	950	1,300,000	470,000		
No. 1		925	625	135	405	850	1,300,000	470,000		
No. 2		550	375	135	405	575	1,100,000	400,000		
<b>Mixed Maple</b>										
Select structural	Beams and stringers	1,150	700	180	620	725	1,100,000	400,000	0.55	NELMA
No. 1		975	500	180	620	600	1,100,000	400,000		
No. 2		625	325	180	620	375	900,000	330,000		
Select structural	Posts and timbers	1,100	725	180	620	750	1,100,000	400,000		
No. 1		875	600	180	620	650	1,100,000	400,000		
No. 2		500	350	180	620	300	900,000	330,000		
<b>Mixed Oak</b>										
Select structural	Beams and stringers	1,350	800	155	800	825	1,000,000	370,000	0.68	NELMA
No. 1		1,150	550	155	800	700	1,000,000	370,000		
No. 2		725	375	155	800	450	800,000	290,000		
Select structural	Posts and timbers	1,250	850	155	800	875	1,000,000	370,000		
No. 1		1,000	675	155	800	775	1,000,000	370,000		
No. 2		575	400	155	800	350	800,000	290,000		
<b>Mixed Southern Pine (Wet service conditions)</b>										
Select structural	5 in. × 5 in. and larger	1,500	1,000	165	375	900	1,300,000	470,000	0.51	SPIB
No. 1		1,350	900	165	375	800	1,300,000	470,000		
No. 2		850	550	165	375	525	1,000,000	370,000		
<b>Southern Pine (Wet service conditions)</b>										
Dense select structural	5 in. × 5 in. and larger	1,750	1,200	165	440	1,100	1,600,000	580,000	0.55	SPIB
Select structural		1,500	1,000	165	375	950	1,500,000	550,000		
No. 1 Dense		1,550	1,050	165	440	975	1,600,000	580,000		
No. 1		1,350	900	165	375	825	1,500,000	550,000		

(Continued)

**TABLE B.4 (Continued)**  
**Reference Design Values for Visually Graded Timbers (5 in. × 5 in. and Larger)**

Species and Commercial Grade	Size Classification	Design Values in Pounds per Square Inch (psi)							Specific Gravity <i>G</i>	Grading Rules Agency
		Bending $F_b$	Tension Parallel to Grain $F_t$	Shear Parallel to Grain $F_v$	Compression Perpendicular to Grain $F_{c\perp}$	Compression Parallel to Grain $F_c$	Modulus of Elasticity			
							$E$	$E_{min}$		
No. 2 Dense		975	650	165	440	625	1,300,000	470,000		
No. 2		850	550	165	375	525	1,200,000	440,000		
Dense select structural 86		2,100	1,400	165	440	1,300	1,600,000	580,000		
Dense select structural 72		1,750	1,200	165	440	1,100	1,600,000	580,000		
Dense select structural 65		1,600	1,050	165	440	1,000	1,600,000	580,000		
<b>Spruce Pine</b>										
To obtain recommended design values for Spruce Pine graded to Southern Pine Inspection Bureau (SPIB) rules, multiply the appropriate design values for Mixed Southern Pine by the corresponding conversion factor shown below. Round off the values to the nearest 100,000 psi for $E$ ; to the nearest 10,000 psi for $E_{min}$ to the next lower multiple of 5 psi for $F_v$ and $F_{c\perp}$ and to the next lower multiple of 50 psi for $F_b$ , $F_t$ , and $F_c$ if the value 1,000 psi or greater, 25 psi otherwise										
		Conversion Factors for Determining Design Values for Spruce Pine							Modulus of Elasticity $E$ and $E_{min}$	
Bending $F_b$	Tension Parallel to Grain $F_t$	Shear Parallel to Grain $F_v$	Compression Perpendicular to Grain $F_{c\perp}$	Compression Parallel to Grain $F_c$					$E$ and $E_{min}$	
0.78	0.78	0.98	0.73	0.78					0.82	



**TABLE B.5**  
**Section Properties of Western Species Structural Glued Laminated Timber (GLULAM)**

Depth $d$ (in.)	Area $A$ (in. <sup>2</sup> )	$x$ - $x$ Axis			$y$ - $y$ Axis	
		$I_x$ (in. <sup>4</sup> )	$S_x$ (in. <sup>3</sup> )	$r_x$ (in.)	$I_y$ (in. <sup>4</sup> )	$S_y$ (in. <sup>3</sup> )
		<b>3<math>\frac{3}{8}</math> in. width</b>			<b>(<math>r_y = 0.902</math> in.)</b>	
6	18.75	56.25	18.75	1.732	15.26	9.766
7-1/2	23.44	109.9	29.30	2.165	19.07	12.21
9	28.13	189.8	42.19	2.598	22.89	14.65
10-1/2	32.81	301.5	57.42	3.031	26.70	17.09
12	37.50	450.0	75.00	3.464	30.52	19.53
13-1/2	42.19	640.7	94.92	3.897	34.33	21.97
15	46.88	878.9	117.2	4.330	38.15	24.41
16-1/2	51.56	1,170	141.8	4.763	41.96	26.86
18	56.25	1,519	168.8	5.196	45.78	29.30
19-1/2	60.94	1,931	198.0	5.629	49.59	31.74
21	65.63	2,412	229.7	6.062	53.41	34.18
22-1/2	70.31	2,966	263.7	6.495	57.22	36.62
24	75.00	3,600	300.0	6.928	61.04	39.06
		<b>5-1/8 in. width</b>			<b>(<math>r_y = 1.479</math> in.)</b>	
6	30.75	92.25	30.75	1.732	67.31	26.27
7-1/2	38.44	180.2	48.05	2.165	84.13	32.83
9	46.13	311.3	69.19	2.598	101.0	39.40
10-1/2	53.81	494.4	94.17	3.031	117.8	45.96
12	61.50	738.0	123.0	3.464	134.6	52.53
13-1/2	69.19	1,051	155.7	3.897	151.4	59.10
15	76.88	1,441	192.2	4.330	168.3	65.66
16-1/2	84.56	1,919	232.5	4.763	185.1	72.23
18	92.25	2,491	276.8	5.196	201.9	78.80
19-1/2	99.94	3,167	324.8	5.629	218.7	85.36
21	107.6	3,955	376.7	6.062	235.6	91.93
22-1/2	115.3	4,865	432.4	6.495	252.4	98.50
24	123.0	5,904	492.0	6.928	269.2	105.1
25-1/2	130.7	7,082	555.4	7.361	286.0	111.6
27	138.4	8,406	622.7	7.794	302.9	118.2
28-1/2	146.1	9,887	693.8	8.227	319.7	124.8
30	153.8	11,530	768.8	8.660	336.5	131.3
31-1/2	161.4	13,350	847.5	9.093	353.4	137.9
33	169.1	15,350	930.2	9.526	370.2	144.5
34-1/2	176.8	17,540	1,017	9.959	387.0	151.0
36	184.5	19,930	1,107	10.39	403.8	157.6
		<b>6-3/4 in. width</b>			<b>(<math>r_y = 1.949</math> in.)</b>	
7-1/2	50.63	237.3	63.28	2.165	192.2	56.95
9	60.75	410.1	91.13	2.598	230.7	68.34
10-1/2	70.88	651.2	124.0	3.031	269.1	79.73
12	81.00	972.0	162.0	3.464	307.5	91.13
13-1/2	91.13	1,384	205.0	3.897	346.0	102.5
15	101.3	1,898	253.1	4.330	384.4	113.9

(Continued)

**TABLE B.5 (Continued)**  
**Section Properties of Western Species Structural Glued Laminated Timber (GLULAM)**

Depth $d$ (in.)	Area $A$ (in. <sup>2</sup> )	$x$ - $x$ Axis			$y$ - $y$ Axis		
		$I_x$ (in. <sup>4</sup> )	$S_x$ (in. <sup>3</sup> )	$r_x$ (in.)	$I_y$ (in. <sup>4</sup> )	$S_y$ (in. <sup>3</sup> )	
			<b>6-3/4 in. width</b>			<b>(<math>r_y = 1.949</math> in.)</b>	
16-1/2	111.4	2,527	306.3	4.763	422.9	125.3	
18	121.5	3,281	364.5	5.196	461.3	136.7	
19-1/2	131.6	4,171	427.8	5.629	499.8	148.1	
21	141.8	5,209	496.1	6.062	538.2	159.5	
22-1/2	151.9	6,407	569.5	6.495	576.7	170.9	
24	162.0	7,776	648.0	6.928	615.1	182.3	
25-1/2	172.1	9,327	731.5	7.361	653.5	193.6	
27	182.3	11,070	820.1	7.794	692.0	205.0	
28-1/2	192.4	13,020	913.8	8.227	730.4	216.4	
30	202.5	15,190	1,013	8.660	768.9	227.8	
31-1/2	212.6	17,580	1,116	9.093	807.3	239.2	
33	222.8	20,210	1,225	9.526	845.8	250.6	
34-1/2	232.9	23,100	1,339	9.959	884.2	262.0	
36	243.0	26,240	1,458	10.39	922.6	273.4	
37-1/2	253.1	29,660	1,582	10.83	961.1	284.8	
39	263.3	33,370	1,711	11.26	999.5	296.2	
40-1/2	273.4	37,370	1,845	11.69	1,038	307.5	
42	283.5	41,670	1,985	12.12	1,076	318.9	
43-1/2	293.6	46,300	2,129	12.56	1,115	330.3	
45	303.8	51,260	2,278	12.99	1,153	341.7	
46-1/2	313.9	56,560	2,433	13.42	1,192	353.1	
48	324.0	62,210	2,592	13.86	1,230	364.5	
49-1/2	334.1	68,220	2,757	14.29	1,269	375.9	
51	344.3	74,620	2,926	14.72	1,307	387.3	
52-1/2	354.4	81,400	3,101	15.16	1,346	398.7	
54	364.5	88,570	3,281	15.59	1,384	410.1	
55-1/2	374.6	96,160	3,465	16.02	1,422	421.5	
57	384.8	104,200	3,655	16.45	1,461	432.8	
58-1/2	394.9	112,600	3,850	16.89	1,499	444.2	
60	405.0	121,500	4,050	17.32	1,538	455.6	
			<b>8-3/4 in. width</b>			<b>(<math>r_y = 2.526</math> in.)</b>	
9	78.75	531.6	118.1	2.598	502.4	114.8	
10-1/2	91.88	844.1	160.8	3.031	586.2	134.0	
12	105.0	1,260	210.0	3.464	669.9	153.1	
13-1/2	118.1	1,794	265.8	3.897	753.7	172.3	
15	131.3	2,461	328.1	4.330	837.4	191.4	
16-1/2	144.4	3,276	397.0	4.763	921.1	210.5	
18	157.5	4,253	472.5	5.196	1,005	229.7	
19-1/2	170.6	5,407	554.5	5.629	1,089	248.8	
21	183.8	6,753	643.1	6.062	1,172	268.0	
22-1/2	196.9	8,306	738.3	6.495	1,256	287.1	
24	210.0	10,080	840.0	6.928	1,340	306.3	
25-1/2	223.1	12,090	948.3	7.361	1,424	325.4	
27	236.3	14,350	1,063	7.794	1,507	344.5	
28-1/2	249.4	16,880	1,185	8.227	1,591	363.7	

**TABLE B.5 (Continued)**  
**Section Properties of Western Species Structural Glued Laminated Timber (GLULAM)**

Depth $d$ (in.)	Area $A$ (in. <sup>2</sup> )	$x$ - $x$ Axis			$y$ - $y$ Axis	
		$I_x$ (in. <sup>4</sup> )	$S_x$ (in. <sup>3</sup> )	$r_x$ (in.)	$I_y$ (in. <sup>4</sup> )	$S_y$ (in. <sup>3</sup> )
		<b>8-3/4 in. width</b>			<b>(<math>r_y = 2.526</math> in.)</b>	
30	262.5	19,690	1,313	8.660	1,675	382.8
31-1/2	275.6	22,790	1,447	9.093	1,759	402.0
33	288.8	26,200	1,588	9.526	1,842	421.1
34-1/2	301.9	29,940	1,736	9.959	1,926	440.2
36	315.0	34,020	1,890	10.39	2,010	459.4
37-1/2	328.1	38,450	2,051	10.83	2,094	478.5
39	341.3	43,250	2,218	11.26	2,177	497.7
40-1/2	354.4	48,440	2,392	11.69	2,261	516.8
42	367.5	54,020	2,573	12.12	2,345	535.9
43-1/2	380.6	60,020	2,760	12.56	2,428	555.1
45	393.8	66,450	2,953	12.99	2,512	574.2
46-1/2	406.9	73,310	3,153	13.42	2,596	593.4
48	420.0	80,640	3,360	13.86	2,680	612.5
49-1/2	433.1	88,440	3,573	14.29	2,763	631.6
51	446.3	96,720	3,793	14.72	2,847	650.8
52-1/2	459.4	105,500	4,020	15.16	2,931	669.9
54	472.5	114,800	4,253	15.59	3,015	689.1
55-1/2	485.6	124,700	4,492	16.02	3,098	708.2
57	498.8	135,000	4,738	16.45	3,182	727.3
58-1/2	511.9	146,000	4,991	16.89	3,266	746.5
60	525.0	157,500	5,250	17.32	3,350	765.6
		<b>10-3/4 in. width</b>			<b>(<math>r_y = 3.103</math> in.)</b>	
12	129.0	1,548	258.0	3.464	1,242	231.1
13-1/2	145.1	2,204	326.5	3.897	1,398	260.0
15	161.3	3,023	403.1	4.330	1,553	288.9
16-1/2	177.4	4,024	487.8	4.763	1,708	317.8
18	193.5	5,225	580.5	5.196	1,863	346.7
19-1/2	209.6	6,642	681.3	5.629	2,019	375.6
21	225.8	8,296	790.1	6.062	2,174	404.5
22-1/2	241.9	10,200	907.0	6.495	2,329	433.4
24	258.0	12,380	1,032	6.928	2,485	462.3
25-1/2	274.1	14,850	1,165	7.361	2,640	491.1
27	290.3	17,630	1,306	7.794	2,795	520.0
28-1/2	306.4	20,740	1,455	8.227	2,950	548.9
30	322.5	24,190	1,613	8.660	3,106	577.8
31-1/2	338.6	28,000	1,778	9.093	3,261	606.7
33	354.8	32,190	1,951	9.526	3,416	635.6
34-1/2	370.9	36,790	2,133	9.959	3,572	664.5
36	387.0	41,800	2,322	10.39	3,727	693.4
37-1/2	403.1	47,240	2,520	10.83	3,882	722.3
39	419.3	53,140	2,725	11.26	4,037	751.2
40-1/2	435.4	59,510	2,939	11.69	4,193	780.0
42	451.5	66,370	3,161	12.12	4,348	808.9
43-1/2	467.6	73,740	3,390	12.56	4,503	837.8
45	483.8	81,630	3,628	12.99	4,659	866.7

(Continued)

**TABLE B.5 (Continued)**  
**Section Properties of Western Species Structural Glued Laminated Timber (GLULAM)**

Depth $d$ (in.)	Area $A$ (in. <sup>2</sup> )	$x-x$ Axis			$y-y$ Axis	
		$I_x$ (in. <sup>4</sup> )	$S_x$ (in. <sup>3</sup> )	$r_x$ (in.)	$I_y$ (in. <sup>4</sup> )	$S_y$ (in. <sup>3</sup> )
		<b>10-3/4 in. width</b>			<b>(<math>r_y = 3.103</math> in.)</b>	
46-1/2	499.9	90,070	3,874	13.42	4,814	895.6
48	516.0	99,070	4,128	13.86	4,969	924.5
49-1/2	532.1	108,700	4,390	14.29	5,124	953.4
51	548.3	118,800	4,660	14.72	5,280	982.3
52-1/2	564.4	129,600	4,938	15.16	5,435	1,011
54	580.5	141,100	5,225	15.59	5,590	1,040
55-1/2	596.6	153,100	5,519	16.02	5,746	1,069
57	612.8	165,900	5,821	16.45	5,901	1,098
58-1/2	628.9	179,300	6,132	16.89	6,056	1,127
60	645.0	193,500	6,450	17.32	6,211	1,156

Source: Courtesy of the American Forest & Paper Association, Washington, DC.

**TABLE B.6**  
**Section Properties of Southern Pine Structural Glued Laminated Timber (GLULAM)**

Depth $d$ (in.)	Area $A$ (in. <sup>2</sup> )	$x-x$ Axis			$y-y$ Axis	
		$I_x$ (in. <sup>4</sup> )	$S_x$ (in. <sup>3</sup> )	$r_x$ (in.)	$I_y$ (in. <sup>4</sup> )	$S_y$ (in. <sup>3</sup> )
		<b>3 in. width</b>			<b>(<math>r_y = 0.866</math> in.)</b>	
5-1/2	16.50	41.59	15.13	1.588	12.38	8.250
6-7/8	20.63	81.24	23.63	1.985	15.47	10.31
8-1/4	24.75	140.4	34.03	2.382	18.56	12.38
9-5/8	28.88	222.9	46.32	2.778	21.66	14.44
11	33.00	332.8	60.50	3.175	24.75	16.50
12-3/8	37.13	473.8	76.57	3.572	27.84	18.56
13-3/4	41.25	649.9	94.53	3.969	30.94	20.63
15-1/8	45.38	865.0	114.4	4.366	34.03	22.69
16-1/2	49.50	1,123	136.1	4.763	37.13	24.75
17-7/8	53.63	1,428	159.8	5.160	40.22	26.81
19-1/4	57.75	1,783	185.3	5.557	43.31	28.88
20-5/8	61.88	2,193	212.7	5.954	46.41	30.94
22	66.00	2,662	242.0	6.351	49.50	33.00
23-3/8	70.13	3,193	273.2	6.748	52.59	35.06
		<b>5 in. width</b>			<b>(<math>r_y = 1.443</math> in.)</b>	
6-7/8	34.38	135.4	39.39	1.985	71.61	28.65
8-1/4	41.25	234.0	56.72	2.382	85.94	34.38
9-5/8	48.13	371.5	77.20	2.778	100.3	40.10
11	55.00	554.6	100.8	3.175	114.6	45.83
12-3/8	61.88	789.6	127.6	3.572	128.9	51.56
13-3/4	68.75	1,083	157.6	3.969	143.2	57.29
15-1/8	75.63	1,442	190.6	4.366	157.6	63.02
16-1/2	82.50	1,872	226.9	4.763	171.9	68.75

**TABLE B.6 (Continued)**  
**Section Properties of Southern Pine Structural Glued Laminated Timber (GLULAM)**

Depth <i>d</i> (in.)	Area <i>A</i> (in. <sup>2</sup> )	x-x Axis			y-y Axis	
		<i>I<sub>x</sub></i> (in. <sup>4</sup> )	<i>S<sub>x</sub></i> (in. <sup>3</sup> )	<i>r<sub>x</sub></i> (in.)	<i>I<sub>y</sub></i> (in. <sup>4</sup> )	<i>S<sub>y</sub></i> (in. <sup>3</sup> )
		<b>5 in. width</b>			<b>(<i>r<sub>y</sub></i> = 1.443 in.)</b>	
17-7/8	89.38	2,380	266.3	5.160	186.2	74.48
19-1/4	96.25	2,972	308.8	5.557	200.5	80.21
20-5/8	103.1	3,656	354.5	5.954	214.8	85.94
22	110.0	4,437	403.3	6.351	229.2	91.67
23-3/8	116.9	5,322	455.3	6.748	243.5	97.40
24-3/4	123.8	6,317	510.5	7.145	257.8	103.1
26-1/8	130.6	7,429	568.8	7.542	272.1	108.9
27-1/2	137.5	8,665	630.2	7.939	286.5	114.6
28-7/8	144.4	10,030	694.8	8.335	300.8	120.3
30-1/4	151.3	11,530	762.6	8.732	315.1	126.0
31-5/8	158.1	13,180	833.5	9.129	329.4	131.8
33	165.0	14,970	907.5	9.526	343.8	137.5
34-3/8	171.9	16,920	984.7	9.923	358.1	143.2
35-3/4	178.8	19,040	1,065	10.32	372.4	149.0
		<b>6-3/4 in. width</b>			<b>(<i>r<sub>y</sub></i> = 1.949 in.)</b>	
6-7/8	46.41	182.8	53.17	1.985	176.2	52.21
8-1/4	55.69	315.9	76.57	2.382	211.4	62.65
9-5/8	64.97	501.6	104.2	2.778	246.7	73.09
11	74.25	748.7	136.1	3.175	281.9	83.53
12-3/8	83.53	1,066	172.3	3.572	317.2	93.97
13-3/4	92.81	1,462	212.7	3.969	352.4	104.4
15-1/8	102.1	1,946	257.4	4.366	387.6	114.9
16-1/2	111.4	2,527	306.3	4.763	422.9	125.3
17-7/8	120.7	3,213	359.5	5.160	458.1	135.7
19-1/4	129.9	4,012	416.9	5.557	493.4	146.2
20-5/8	139.2	4,935	478.6	5.954	528.6	156.6
22	148.5	5,990	544.5	6.351	563.8	167.1
23-3/8	157.8	7,184	614.7	6.748	599.1	177.5
24-3/4	167.1	8,528	689.1	7.145	634.3	187.9
26-1/8	176.3	10,030	767.8	7.542	669.6	198.4
27-1/2	185.6	11,700	850.8	7.939	704.8	208.8
28-7/8	194.9	13,540	938.0	8.335	740.0	219.3
30-1/4	204.2	15,570	1,029	8.732	775.3	229.7
31-5/8	213.5	17,790	1,125	9.129	810.5	240.2
33	222.8	20,210	1,225	9.526	845.8	250.6
34-3/8	232.0	22,850	1,329	9.923	881.0	261.0
35-3/4	241.3	25,700	1,438	10.32	916.2	271.5
37-1/8	250.6	28,780	1,551	10.72	951.5	281.9
38-1/2	259.9	32,100	1,668	11.11	986.7	292.4
39-7/8	269.2	35,660	1,789	11.51	1,022	302.8
41-1/4	278.4	39,480	1,914	11.91	1,057	313.2
42-5/8	287.7	43,560	2,044	12.30	1,092	323.7
44	297.0	47,920	2,178	12.70	1,128	334.1
45-3/8	306.3	52,550	2,316	13.10	1,163	344.6
46-3/4	315.6	57,470	2,459	13.50	1,198	355.0
48-1/8	324.8	62,700	2,606	13.89	1,233	365.4

(Continued)

**TABLE B.6 (Continued)**  
**Section Properties of Southern Pine Structural Glued Laminated Timber (GLULAM)**

Depth <i>d</i> (in.)	Area <i>A</i> (in. <sup>2</sup> )	x-x Axis			y-y Axis	
		<i>I<sub>x</sub></i> (in. <sup>4</sup> )	<i>S<sub>x</sub></i> (in. <sup>3</sup> )	<i>r<sub>x</sub></i> (in.)	<i>I<sub>y</sub></i> (in. <sup>4</sup> )	<i>S<sub>y</sub></i> (in. <sup>3</sup> )
		<b>6-3/4 in. width</b>			<b>(<i>r<sub>y</sub></i> = 1.949 in.)</b>	
49-1/2	334.1	68,220	2,757	14.29	1,269	375.9
50-7/8	343.4	74,070	2,912	14.69	1,304	386.3
52-1/4	352.7	80,240	3,071	15.08	1,339	396.8
53-5/8	362.0	86,740	3,235	15.48	1,374	407.2
55	371.3	93,590	3,403	15.88	1,410	417.7
56-3/8	380.5	100,800	3,575	16.27	1,445	428.1
57-3/4	389.8	108,300	3,752	16.67	1,480	438.5
59-1/8	399.1	116,300	3,933	17.07	1,515	449.0
60-1/2	408.4	124,600	4,118	17.46	1,551	459.4
		<b>8-1/2 in. width</b>			<b>(<i>r<sub>y</sub></i> = 2.454 in.)</b>	
9-5/8	81.81	631.6	131.2	2.778	492.6	115.9
11	93.50	942.8	171.4	3.175	562.9	132.5
12-3/8	105.2	1,342	216.9	3.572	633.3	149.0
13-3/4	116.9	1,841	267.8	3.969	703.7	165.6
15-1/8	128.6	2,451	324.1	4.366	774.1	182.1
16-1/2	140.3	3,182	385.7	4.763	844.4	198.7
17-7/8	151.9	4,046	452.6	5.160	914.8	215.2
19-1/4	163.6	5,053	525.0	5.557	985.2	231.8
20-5/8	175.3	6,215	602.6	5.954	1,056	248.4
22	187.0	7,542	685.7	6.351	1,126	264.9
23-3/8	198.7	9,047	774.1	6.748	1,196	281.5
24-3/4	210.4	10,740	867.8	7.145	1,267	298.0
26-1/8	222.1	12,630	966.9	7.542	1,337	314.6
27-1/2	233.8	14,730	1,071	7.939	1,407	331.1
28-7/8	245.4	17,050	1,181	8.335	1,478	347.7
30-1/4	257.1	19,610	1,296	8.732	1,548	364.3
31-5/8	268.8	22,400	1,417	9.129	1,618	380.8
33	280.5	25,460	1,543	9.526	1,689	397.4
34-3/8	292.2	28,770	1,674	9.923	1,759	413.9
35-3/4	303.9	32,360	1,811	10.32	1,830	430.5
37-1/8	315.6	36,240	1,953	10.72	1,900	447.0
38-1/2	327.3	40,420	2,100	11.11	1,970	463.6
39-7/8	338.9	44,910	2,253	11.51	2,041	480.2
41-1/4	350.6	49,720	2,411	11.91	2,111	496.7
42-5/8	362.3	54,860	2,574	12.30	2,181	513.3
44	374.0	60,340	2,743	12.70	2,252	529.8
45-3/8	385.7	66,170	2,917	13.10	2,322	546.4
46-3/4	397.4	72,370	3,096	13.50	2,393	562.9
48-1/8	409.1	78,950	3,281	13.89	2,463	579.5
49-1/2	420.8	85,910	3,471	14.29	2,533	596.1
50-7/8	432.4	93,270	3,667	14.69	2,604	612.6
52-1/4	444.1	101,000	3,868	15.08	2,674	629.2
53-5/8	455.8	109,200	4,074	15.48	2,744	645.7
55	467.5	117,800	4,285	15.88	2,815	662.3
56-3/8	479.2	126,900	4,502	16.27	2,885	678.8

**TABLE B.6 (Continued)**  
**Section Properties of Southern Pine Structural Glued Laminated Timber (GLULAM)**

Depth <i>d</i> (in.)	Area <i>A</i> (in. <sup>2</sup> )	<i>x-x</i> Axis			<i>y-y</i> Axis	
		<i>I<sub>x</sub></i> (in. <sup>4</sup> )	<i>S<sub>x</sub></i> (in. <sup>3</sup> )	<i>r<sub>x</sub></i> (in.)	<i>I<sub>y</sub></i> (in. <sup>4</sup> )	<i>S<sub>y</sub></i> (in. <sup>3</sup> )
		<b>8-1/2 in. width</b>			<b>(<i>r<sub>y</sub></i> = 2.454 in.)</b>	
57-3/4	490.9	136,400	4,725	16.67	2,955	695.4
59-1/8	502.6	146,400	4,952	17.07	3,026	712.0
60-1/2	514.3	156,900	5,185	17.46	3,096	728.5
		<b>10-1/2 in. width</b>			<b>(<i>r<sub>y</sub></i> = 3.031 in.)</b>	
11	115.5	1,165	211.8	3.175	1,061	202.1
12-3/8	129.9	1,658	268.0	3.572	1,194	227.4
13-3/4	144.4	2,275	330.9	3.969	1,326	252.7
15-1/8	158.8	3,028	400.3	4.366	1,459	277.9
16-1/2	173.3	3,931	476.4	4.763	1,592	303.2
17-7/8	187.7	4,997	559.2	5.160	1,724	328.5
19-1/4	202.1	6,242	648.5	5.557	1,857	353.7
20-5/8	216.6	7,677	744.4	5.954	1,990	379.0
22	231.0	9,317	847.0	6.351	2,122	404.3
23-3/8	245.4	11,180	956.2	6.748	2,255	429.5
24-3/4	259.9	13,270	1,072	7.145	2,388	454.8
26-1/8	274.3	15,600	1,194	7.542	2,520	480.0
27-1/2	288.8	18,200	1,323	7.939	2,653	505.3
28-7/8	303.2	21,070	1,459	8.335	2,786	530.6
30-1/4	317.6	24,220	1,601	8.732	2,918	555.8
31-5/8	332.1	27,680	1,750	9.129	3,051	581.1
33	346.5	31,440	1,906	9.526	3,183	606.4
34-3/8	360.9	35,540	2,068	9.923	3,316	631.6
35-3/4	375.4	39,980	2,237	10.32	3,449	656.9
37-1/8	389.8	44,770	2,412	10.72	3,581	682.2
38-1/2	404.3	49,930	2,594	11.11	3,714	707.4
39-7/8	418.7	55,480	2,783	11.51	3,847	732.7
41-1/4	433.1	61,420	2,978	11.91	3,979	758.0
42-5/8	447.6	67,760	3,180	12.30	4,112	783.2
44	462.0	74,540	3,388	12.70	4,245	808.5
45-3/8	476.4	81,740	3,603	13.10	4,377	833.8
46-3/4	490.9	89,400	3,825	13.50	4,510	859.0
48-1/8	505.3	97,530	4,053	13.89	4,643	884.3
49-1/2	519.8	106,100	4,288	14.29	4,775	909.6
50-7/8	534.2	115,200	4,529	14.69	4,908	934.8
52-1/4	548.6	124,800	4,778	15.08	5,040	960.1
53-5/8	563.1	134,900	5,032	15.48	5,173	985.4
55	577.5	145,600	5,294	15.88	5,306	1,011
56-3/8	591.9	156,800	5,562	16.27	5,438	1,036
57-3/4	606.4	168,500	5,836	16.67	5,571	1,061
59-1/8	620.8	180,900	6,118	17.07	5,704	1,086
60-1/2	635.3	193,800	6,405	17.46	5,836	1,112

Source: Courtesy of the American Forest & Paper Association, Washington, DC.

**TABLE B.7**  
**Reference Design Values for Structural Glued Laminated Softwood Timber Combinations<sup>a</sup> (Members Stressed Primarily in Bending)**

Combination Symbol	Species Outer/Core	Bending About x-x Axis (Loaded Perpendicular to Wide Faces of Laminations)										Bending About y-y Axis (Loaded Parallel to Wide Faces of Laminations)											
		Bottom of Beam Stressed in Tension (Positive Bending)					Top of Beam Stressed in Tension (Negative Bending)					Bottom Face					Top Face						
		$F_{bx}^+$ (psi)	$F_{bx}^-$ (psi)	$F_{ct,x}$ (psi)	Tension Face	Compression Face	$F_{bx}^+$ (psi)	$F_{bx}^-$ (psi)	$F_{ct,y}$ (psi)	Tension Face	Compression Face	$F_{cy}$ (psi)	$F_{cy}^{b,c}$ (psi)	For Deflection Calculations	For Stability Calculations	$E_y$ ( $10^6$ psi)	$E_{min}$ ( $10^6$ psi)	$F_t$ (psi)	Compression Parallel to Grain	Tension Parallel to Grain	Axially Loaded	Fasteners	
16F-1.3E		1600	925	315	560	560	195	1.3	0.69	800	315	170	1.1	0.58	675	925	0.41						
16F-V3	DF/DF	1600	1250	560	560	560	265	1.5	0.79	1450	560	230	1.5	0.79	975	1500	0.50	0.50					
16F-V6	DF/DF	1600	1600	560	560	560	265	1.6	0.85	1450	560	230	1.5	0.79	1000	1600	0.50	0.50					
16F-E2	HE/HE	1600	1050	375	375	375	215	1.4	0.74	1200	375	190	1.3	0.69	825	1150	0.43	0.43					
16F-E3	DF/DF	1600	1200	560	560	560	265	1.6	0.85	1400	560	230	1.5	0.79	975	1600	0.50	0.50					
16F-E6	DF/DF	1600	1600	560	560	560	265	1.6	0.85	1550	560	230	1.5	0.79	1000	1600	0.50	0.50					
16F-E7	HE/HE	1600	1600	375	375	375	215	1.4	0.74	1350	375	190	1.3	0.74	875	1250	0.43	0.43					
16F-V2	SP/SP	1600	1400	740	740	740	300	1.5	0.79	1450	650	260	1.4	0.74	1000	1300	0.55	0.55					
16F-V3	SP/SP	1600	1450	740	740	740	300	1.4	0.74	1450	650	260	1.4	0.74	975	1400	0.55	0.55					
16F-V5	SP/SP	1600	1600	650	650	650	300	1.6	0.85	1600	650	260	1.5	0.79	1000	1550	0.55	0.55					
16F-E1	SP/SP	1600	1250	650	650	650	300	1.6	0.85	1400	650	260	1.6	0.85	1050	1550	0.55	0.55					
16F-E3	SP/SP	1600	1600	650	650	650	300	1.7	0.90	1650	650	260	1.6	0.85	1100	1550	0.55	0.55					
20F-1.5E		2000	1100	425	500	500	195	1.5	0.79	800	315	170	1.2	0.63	725	925	0.41						
20F-V3	DF/DF	2000	1450	650	650	650	265	1.6	0.85	1450	560	230	1.5	0.79	1000	1550	0.50	0.50					
20F-V7	DF/DF	2000	2000	650	650	650	265	1.6	0.85	1450	560	230	1.6	0.85	1050	1600	0.50	0.50					
20F-V12	AC/AC	2000	1400	560	560	560	265	1.5	0.79	1250	470	230	1.4	0.74	925	1500	0.46	0.46					
20F-V13	AC/AC	2000	2000	560	560	560	265	1.5	0.79	1250	470	230	1.4	0.74	950	1550	0.46	0.46					
20F-V14	POC/POC	2000	1450	560	560	560	265	1.5	0.79	1300	470	230	1.4	0.74	900	1600	0.46	0.46					
20F-V15	POC/POC	2000	2000	560	560	560	265	1.5	0.79	1300	470	230	1.4	0.74	900	1600	0.46	0.46					
20F-E2	HE/HE	2000	1400	500	500	500	215	1.6	0.85	1200	375	190	1.4	0.74	925	1350	0.43	0.43					



20F-E3	DF/DF	2000	1200	560	560	265	1.7	0.90	1400	560	230	1.6	0.85	1050	1600	0.50	0.50
20F-E6	DF/DF	2000	2000	560	560	265	1.7	0.90	1550	560	230	1.6	0.85	1150	1650	0.50	0.50
20F-E7	HF/HF	2000	2000	500	500	215	1.6	0.85	1450	375	190	1.4	0.74	1050	1450	0.43	0.43
20F-E8	ES/ES	2000	1300	450	450	200	1.5	0.79	1000	315	175	1.4	0.74	825	1100	0.41	0.41
24F-E/SPF1	SPF/SPF	2400	2400	560	560	215	1.6	0.85	1150	470	190	1.6	0.85	1150	2000	0.42	0.42
24F-E/SPF3	SPF/SPF	2400	1550	560	560	215	1.6	0.85	1200	470	195	1.5	0.79	900	1750	0.42	0.42
20F-V2	SP/SP	2000	2000	740	740	300	1.5	0.79	1450	650	260	1.4	0.74	1000	1400	0.55	0.55
20F-V3	SP/SP	2000	1450	650	650	300	1.5	0.79	1600	650	260	1.5	0.79	1000	1400	0.55	0.55
20F-V5	SP/SP	2000	2000	740	740	300	1.6	0.85	1450	650	260	1.4	0.74	1050	1500	0.55	0.55
20F-E1	SP/SP	2000	1300	650	650	300	1.7	0.90	1400	650	260	1.6	0.85	1050	1550	0.55	0.55
20F-E3	SP/SP	2000	2000	650	650	300	1.7	0.90	1700	650	260	1.6	0.85	1150	1600	0.55	0.55
<b>24F-1.7E</b>		<b>2400</b>	<b>1450</b>	<b>500</b>		<b>210</b>	<b>1.7</b>	<b>0.90</b>	<b>1050</b>	<b>315</b>	<b>185</b>	<b>1.3</b>	<b>0.69</b>	<b>775</b>	<b>1000</b>	<b>0.42</b>	
24F-V5	DF/HF	2400	1600	650	650	215	1.7	0.90	1350	375	200	1.5	0.79	1100	1450	0.50	0.43
24F-V10	DF/HF	2400	2400	650	650	215	1.8	0.95	1450	375	200	1.5	0.79	1150	1550	0.50	0.43
24F-E11	HF/HF	2400	2400	500	500	215	1.8	0.95	1550	375	190	1.5	0.79	1150	1550	0.43	0.43
24F-E15	HF/HF	2400	1600	500	500	215	1.7	0.95	1200	375	190	1.5	0.79	975	1500	0.43	0.43
24F-V1	SP/SP	2400	1750	740	650	300	1.7	0.90	1450	650	260	1.5	0.79	1100	1500	0.55	0.55
24F-V4 <sup>4</sup>	SP/SP	2400	1650	740	650	210	1.7	0.90	1350	470	230	1.5	0.79	975	1350	0.55	0.43
24F-V5	SP/SP	2400	2400	740	740	300	1.7	0.90	1700	650	260	1.6	0.85	1150	1600	0.55	0.55
<b>24F-1.8E</b>		<b>2400</b>	<b>1450</b>	<b>650</b>		<b>265</b>	<b>1.8</b>	<b>0.95</b>	<b>1450</b>	<b>560</b>	<b>230</b>	<b>1.6</b>	<b>0.85</b>	<b>1100</b>	<b>1600</b>	<b>0.50</b>	
24F-V4	DF/DF	2400	1850	650	650	265	1.8	0.95	1450	560	230	1.6	0.85	1100	1650	0.50	0.50
24F-V8	DF/DF	2400	2400	650	650	265	1.8	0.95	1550	560	230	1.6	0.85	1100	1650	0.50	0.50
24F-E4	DF/DF	2400	1450	650	650	265	1.8	0.95	1400	560	230	1.7	0.90	1100	1700	0.50	0.50
24F-E13	DF/DF	2400	2400	650	650	265	1.8	0.95	1750	560	230	1.7	0.90	1250	1700	0.50	0.50
24F-E18	DF/DF	2400	2400	650	650	265	1.8	0.95	1550	560	230	1.7	0.90	975	1700	0.50	0.50
24F-V3	SP/SP	2400	2000	740	740	300	1.8	0.95	1700	650	260	1.6	0.85	1150	1650	0.55	0.55
24F-V8	SP/SP	2400	2400	740	740	300	1.8	0.95	1700	650	260	1.6	0.85	1150	1650	0.55	0.55
24F-E1	SP/SP	2400	1450	805	650	300	1.8	0.95	1550	650	260	1.7	0.90	1150	1600	0.55	0.55
24F-E4	SP/SP	2400	2400	805	805	300	1.9	1.00	1850	650	260	1.8	0.95	1450	1750	0.55	0.55
<b>26F-1.9E</b>		<b>2600</b>	<b>1950</b>	<b>650</b>		<b>265</b>	<b>1.9</b>	<b>1.00</b>	<b>1600</b>	<b>560</b>	<b>230</b>	<b>1.6</b>	<b>0.85</b>	<b>1150</b>	<b>1600</b>	<b>0.50</b>	
26F-V1	DF/DF	2600	1950	650	650	265	2.0	1.06	1850	560	230	1.8	0.95	1350	1850	0.50	0.50
26F-V2	DF/DF	2600	2600	650	650	265	2.0	1.06	1850	560	230	1.8	0.95	1350	1850	0.50	0.50
26F-V1	SP/SP	2600	2000	740	740	300	1.8	0.95	1700	650	260	1.6	0.85	1150	1600	0.55	0.55
26F-V2	SP/SP	2600	2100	740	740	300	1.9	1.00	1950	740	260	1.8	0.95	1300	1850	0.55	0.55
26F-V3	SP/SP	2600	2100	740	740	300	1.9	1.00	1950	650	260	1.8	0.95	1250	1800	0.55	0.55
26F-V4	SP/SP	2600	2600	740	740	300	1.9	1.00	1700	650	260	1.8	0.95	1200	1600	0.55	0.55

(Continued)

**TABLE B.7 (Continued)**  
**Reference Design Values for Structural Glued Laminated Softwood Timber Combinations<sup>a</sup> (Members Stressed Primarily in Bending)**

Combination Symbol	Species Outer/Core	Bending About x-x Axis (Loaded Perpendicular to Wide Faces of Laminations)						Bending About y-y Axis (Loaded Parallel to Wide Faces of Laminations)						Fasteners								
		Bottom of Beam			Top of Beam			Shear Parallel to Grain			Shear Parallel to Grain				Axially Loaded							
		Stressed in Tension (Positive Bending)	$F_{t\alpha}^-$ (psi)	$F_{t\alpha}^+$ (psi)	Stressed in Tension (Negative Bending)	$F_{t\alpha}^-$ (psi)	$F_{t\alpha}^+$ (psi)	Compression Perpendicular to Grain	Compression Parallel to Grain	Modulus of Elasticity	Bending	Compression Perpendicular to Grain	Compression Parallel to Grain		Modulus of Elasticity	Tension Parallel to Grain	Compression Parallel to Grain	Specific Gravity for Fastener Design				
26F-V5	SP/SP	2600	2600	740	740	740	$F_{c\perp\alpha}$ (psi)	$F_{c\parallel\alpha}$ (psi)	$E_x$ (10 <sup>6</sup> psi)	$E_y$ (10 <sup>6</sup> psi)	$E_{min}$ (10 <sup>6</sup> psi)	$F_{b\perp}$ (psi)	$F_{b\parallel}$ (psi)	$F_{c\perp y}$ (psi)	$F_{c\parallel y}$ (psi)	$E_y$ (10 <sup>6</sup> psi)	$E_{min}$ (10 <sup>6</sup> psi)	$F_t$ (psi)	$F_c$ (psi)	G	0.55	0.55
28F-2.1E SP	SP/SP	2800	2300	805	805	805	805	805	2.1	1.1	1.1	1600	1600	650	650	1.7	0.90	1250	1750	0.55	0.55	
28F-E1	SP/SP	2800	2300	805	805	805	805	805	2.1	1.1	1.1	1600	1600	650	650	1.7	0.90	1300	1850	0.55	0.55	
28F-E2	SP/SP	2600	2800	805	805	805	805	805	2.1	1.1	1.1	2000	2000	650	650	1.7	0.90	1300	1300	0.55	0.55	
30F-2.1E SP	SP/SP	3000	2400	805	805	805	805	805	2.1	1.1	1.1	1750	1750	650	650	1.7	0.90	1250	1750	0.55	0.55	
30F-E1	SP/SP	3000	2400	805	805	805	805	805	2.1	1.1	1.1	1750	1750	650	650	1.7	0.90	1250	1750	0.55	0.55	
30F-E2	SP/SP	3000	3000	805	805	805	805	805	2.1	1.1	1.1	1750	1750	650	650	1.7	0.90	1350	1750	0.55	0.55	

<sup>a</sup> The combinations in this table are applicable to members consisting of four or more laminations and are intended primarily for members stressed in bending due to loads applied perpendicular to the wide faces of the laminations. However, reference design values are tabulated for loading both perpendicular and parallel to the wide faces of the laminations. For combinations and reference design values applicable to members loaded primarily axially or parallel to the wide faces of the laminations, see Table B.8. For members of two or three laminations, see Table B.8.

<sup>b</sup> The reference design values for shear,  $F_{t\alpha}$ , and  $F_{t\beta}$  shall be multiplied by the shear reduction factor,  $C_{1p}$ , for the conditions defined in NDS 5.3.10.

<sup>c</sup> Reference design values are for structural glued laminated timbers with laminations made from a single piece of lumber across the width or multiple pieces that have been edge-bonded. For structural glued laminated timber manufactured from multiple reference design values (across width) that are not edge-bonded, value shall be multiplied by 0.4 for members with five, seven, or nine laminations or by 0.5 for all other members. This reduction shall be cumulative with the adjustment in the preceding footnote.

<sup>d</sup> This combination may contain lumber with wane. If lumber with wane is used, the reference design value for shear parallel to grain,  $F_{t\alpha}$ , shall be multiplied by 0.67 if wane is allowed on both sides. If wane is limited to one side,  $F_{t\alpha}$  shall be multiplied by 0.83. This reduction shall be cumulative with the adjustment in footnote b.

**TABLE B.8**  
**Reference Design Values for Structural Glued Laminated Softwood Timber (Members Stressed Primarily in Axial Tension or Compression)**

Combination Symbol	Species	Grade	All Loading			Axially Loaded				Bending About y-y Axis (Loaded Parallel to Wide Faces of Laminations)				Bending About x-x Axis (Loaded Perpendicular to Wide Faces of Laminations)		Fasteners	
			Modulus of Elasticity			Tension Parallel to Grain		Compression Parallel to Grain		Bending		Shear Parallel to Grain <sup>a,b,c</sup>		Bending			Shear Parallel to Grain <sup>c</sup>
			Deflection Calculations	For Stability Calculations	$E_{min}$ (10 <sup>6</sup> psi)	$F_t$ (psi)	Two or More Laminations	Four or More Laminations	Two or Three or More Laminations	Three Laminations	Four or More Laminations	Two Laminations	$F_{by}$ (psi)	$F_{bx}$ (psi)	Two Laminations to 15 in. Deep <sup>d</sup>		
																	$E$ (10 <sup>6</sup> psi)
Visually Graded Western Species																	
1	DF	L3	1.5	0.79	560	950	1550	1250	1450	1250	1000	230	1250	265	0.50		
2	DF	L2	1.6	0.85	560	1250	1950	1600	1800	1600	1300	230	1700	265	0.50		
3	DF	L2D	1.9	1.00	650	1450	2300	1900	2100	1850	1550	230	2000	265	0.50		
4	DF	L1CL	1.9	1.00	590	1400	2100	1950	2200	2000	1650	230	2100	265	0.50		
5	DF	L1	2.0	1.06	650	1650	2400	2100	2400	2100	1800	230	2200	265	0.50		
14	HF	L3	1.3	0.69	375	800	1100	1050	1200	1050	850	190	1100	215	0.43		
15	HF	L2	1.4	0.74	375	1050	1350	1350	1500	1350	1100	190	1450	215	0.43		
16	HF	L1	1.6	0.85	375	1200	1500	1500	1750	1550	1300	190	1600	215	0.43		
17	HF	L1D	1.7	0.90	500	1400	1750	1750	2000	1850	1550	190	1900	215	0.43		
22	SW	L3	1.0	0.53	315	525	850	725	800	700	575	170	725	195	0.35		
69	AC	L3	1.2	0.63	470	725	1150	1100	1100	975	775	230	1000	265	0.46		
70	AC	L2	1.3	0.69	470	975	1450	1450	1400	1250	1000	230	1350	265	0.46		
71	AC	L1D	1.6	0.85	560	1250	1900	1900	1850	1650	1400	230	1750	265	0.46		
72	AC	L1S	1.6	0.85	560	1250	1900	1900	1850	1650	1400	230	1900	265	0.46		
73	POC	L3	1.3	0.69	470	775	1500	1200	1200	1050	825	230	1050	265	0.46		
74	POC	L2	1.4	0.74	470	1050	1900	1550	1450	1300	1100	230	1400	265	0.46		
75	POC	L1D	1.7	0.90	560	1350	2300	2050	1950	1750	1500	230	1850	265	0.46		
Visually Graded Southern Pine																	
47	SP	N2M12	1.4	0.74	650	1200	1900	1150	1750	1550	1300	260	1400	300	0.55		
47 1:10	SP	N2M10	1.4	0.74	650	1150	1700	1150	1750	1550	1300	260	1400	300	0.55		
47 1:8	SP	N2M	1.4	0.74	650	1000	1500	1150	1600	1550	1300	260	1400	300	0.55		

(Continued)

**TABLE B.8 (Continued)**  
**Reference Design Values for Structural Glued Laminated Softwood Timber (Members Stressed Primarily in Axial Tension or Compression)**

Combination Symbol	Species	Grade	All Loading			Axially Loaded				Bending About y-y Axis (Loaded Parallel to Wide Faces of Laminations)				Bending About x-x Axis (Loaded Perpendicular to Wide Faces of Laminations)		Fasteners	
			Modulus of Elasticity			Tension Parallel to Grain		Compression Parallel to Grain		Bending		Shear Parallel to Grain <sup>a,b,c</sup>		Bending			Shear Parallel to Grain
			For Deflection Calculations	For Stability Calculations	$E_{min}$ (10 <sup>6</sup> psi)	$F_t$ (psi)	Two or More Laminations	Four or More Laminations	Two or Three or More Laminations	$F_c$ (psi)	Two or More Laminations	Four or More Laminations	Three Laminations	Two Laminations	$F_{by}$ (psi)		
48	SP	N2D12	1.7	0.90	740	1400	2200	1350	1800	1500	260	1600	300	0.55			
48 1:10	SP	N2D10	1.7	0.90	740	1350	2000	1350	1800	1500	260	1600	300	0.55			
48 1:8	SP	N2D	1.7	0.90	740	1150	1750	1350	1800	1500	260	1600	300	0.55			
49	SP	N1M16	1.7	0.90	650	1350	2100	1450	1750	1500	260	1800	300	0.55			
49 1:14	SP	N1M14	1.7	0.90	650	1350	2000	1450	1750	1500	260	1800	300	0.55			
49 1:12	SP	N1M12	1.7	0.90	650	1300	1900	1450	1750	1500	260	1800	300	0.55			
49 1:10	SP	N1M	1.7	0.90	650	1150	1700	1450	1850	1500	260	1800	300	0.55			
50	SP	N1D14	1.9	1.00	740	1550	2300	1700	2100	1750	260	2100	300	0.55			
50 1:12	SP	N1D12	1.9	1.00	740	1500	2200	1700	2100	1750	260	2100	300	0.55			
50 1:10	SP	N1D	1.9	1.00	740	1350	2000	1700	2100	1750	260	2100	300	0.55			

<sup>a</sup> For members with two or three laminations, the reference shear design value for transverse loads parallel to the wide faces of the laminations,  $F_{vt}$ , shall be reduced by multiplying by a factor of 0.84 for two laminations or 0.95, for three laminations.  
<sup>b</sup> The reference shear design value for transverse loads applied parallel to the wide faces of the laminations,  $F_{vt}$ , shall be multiplied by 0.4 for members with five, seven, or nine laminations manufactured from multiple piece laminations (across width) that are not edge-bonded. The reference shear design value,  $F_{vt}$ , shall be multiplied by 0.5 for all other members manufactured from multiple-piece laminations with unbonded edge joints. This reduction shall be cumulative with the adjustments in footnotes a and c.  
<sup>c</sup> The reference design values for shear,  $F_{vt}$ , and  $F_{vs}$  shall be multiplied by the shear reduction factor,  $C_{vt}$ , for the conditions defined in NDS 5.3.10.  
<sup>d</sup> For members greater than 15 in. deep, the reference bending design value,  $F_{bx}$ , shall be reduced by multiplying by a factor of 0.88.

**TABLE B.9**  
**Reference Design Values for Structural Composite Lumber**

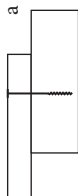
Grade	Orientation	Shear of Elasticity $G$ (psi)	Modulus of Elasticity	Flexural Stress $F_b^a$ (psi)	Tension Stress $F_t^b$ (psi)	Compression Perpendicular to Grain $F_{c\perp}^c$ (psi)	Compression Parallel to Grain $F_{c\parallel}$ (psi)	Horizontal Shear Parallel to Grain $F_v$ (psi)
			Elasticity $E$ (psi)					
<b>TimberStrand LSL</b>								
1.3E	Beam/Column	81,250	$1.3 \times 10^6$	3,140	1,985	1,240	2,235	745
	Plank	81,250	$1.3 \times 10^6$	3,510		790	2,235	280
1.55E	Beam	96,875	$1.55 \times 10^6$	4,295	1,975	1,455	3,270	575
<b>Microllam LVL</b>								
1.9E	Beam	118,750	$1.9 \times 10^6$	4,805	2,870	1,365	4,005	530
<b>Parallam PSL</b>								
1.8E			$1.8 \times 10^6$					
and 2.0E	Column	112,500	$2.0 \times 10^6$	4,435	3,245	775	3,990	355
2.0E	Beam	125,000	$2.0 \times 10^6$	5,360	3,750	1,365	4,630	540

<sup>a</sup> For 12-in. depth and for other depths, multiply,  $F_b$ , by the factors as follows: For TimberStrand LSL, multiply by  $[12/d]^{0.092}$ ; for Microllam LVL, multiply by  $[12/d]^{0.136}$ ; for Parallam, PSL, multiply by  $[12/d]^{0.111}$ .

<sup>b</sup>  $F_t$  has been adjusted to reflect the volume effects for most standard applications.

<sup>c</sup>  $F_{c\perp}$  shall not be increased for duration of load.

**TABLE B.10**  
**Common Wire, Box, or Sinker Nails: Reference Lateral Design Values (Z) for Single-Shear (Two-Member) Connections**



Side Member Thickness, $t_s$ (in.)	Nail Diameter, $D$ (in.)	Common Wire Nail		Sinker Nail	Pennyweight	$G = 0.67$ , Red Oak (lb)			$G = 0.55$ , Mixed Maple Southern Pine (lb)		$G = 0.5$ , Douglas Fir-Larch (lb)		$G = 0.49$ , Douglas Fir-Larch (North) (lb)		$G = 0.46$ , Douglas Fir Hem-Fir (North) (lb)		$G = 0.43$ , Hem-Fir (lb)		$G = 0.42$ , Spruce-Pine-Fir (lb)		$G = 0.37$ , Redwood (Open Grain) (lb)		$G = 0.36$ , Eastern Softwoods Spruce-Pine-Fir (South) Western Cedars Western Woods (lb)		$G = 0.35$ , Northern Species (lb)		
		Box Nail	Box Nail																								
3/4	0.099			6d	7d	73		61	55	54	51	48	47	39	38										36		
	0.113	6d		8d		94	79	72	71	71	65	58	57	47	46										44		
	0.120				10d	107	89	80	77	77	71	64	62	52	50										48		
	0.128				10d	121	101	87	84	84	78	70	68	57	56										54		
	0.131		8d			127	104	90	87	87	80	73	70	60	58										56		
	0.135			16d	12d	135	108	94	91	91	84	76	74	63	61										58		
	0.148	10d		20d	16d	154	121	105	102	102	94	85	83	70	69										66		
	0.162	16d		40d		183	138	121	117	117	108	99	96	82	80										77		
	0.177				20d	200	153	134	130	130	121	111	107	92	90										87		
	0.192	20d			30d	206	157	138	134	134	125	114	111	96	93										90		
	0.207	30d			40d	216	166	147	143	143	133	122	119	103	101										97		
	0.225	40d				229	178	158	154	154	144	132	129	112	110										106		
	0.244	50d			60d	234	182	162	158	158	147	136	132	115	113										109		
1	0.099			6d	7d	73		61	55	54	51	48	47	42	41										40		
	0.113			8d		94	79	72	71	71	67	63	61	55	54										51		
	0.120				10d	107	89	81	80	80	76	71	69	60	59										56		
	0.128				10d	121	101	93	91	91	86	80	79	66	64										61		
	0.131		8d			127	106	97	95	95	90	84	82	68	66										63		
	0.135			16d	12d	135	113	103	101	101	96	89	86	71	69										66		
	0.148	10d		20d	16d	154	128	118	115	115	109	99	96	80	77										74		
	0.162	16d		40d		184	154	141	137	137	125	113	109	91	89										85		
	0.177				20d	213	178	155	150	150	138	125	121	102	99										95		
	0.192	20d			30d	222	183	159	154	154	142	128	124	105	102										98		
	0.207	30d			40d	243	192	167	162	162	149	135	131	111	109										104		

	0.225	40d		268	202	177	171	159	144	140	120	117	112
	0.244	50d	60d	274	207	181	175	162	148	143	123	120	115
1/4	0.099		6d	73	61	55	54	51	48	47	42	41	40
	0.113	6d	8d	94	79	72	71	67	63	61	55	54	52
	0.120		10d	107	89	81	80	76	71	69	62	60	59
	0.128		10d	121	101	93	91	86	80	79	70	69	67
	0.131	8d		127	106	97	95	90	84	82	73	72	70
	0.135		16d	135	113	103	101	96	89	88	78	76	74
	0.148	10d	20d	154	128	118	115	109	102	100	89	87	84
	0.162	16d	40d	184	154	141	138	131	122	120	103	100	95
	0.177			213	178	163	159	151	141	136	113	110	105
	0.192	20d	30d	222	185	170	166	157	145	140	116	113	108
	0.207	30d	40d	243	203	186	182	169	152	147	123	119	114
	0.225	40d		268	224	200	193	177	160	155	130	127	121
	0.244	50d	60d	276	230	204	197	181	163	158	133	129	124
1/2	0.099		7d	73	61	55	54	51	48	47	42	41	40
	0.113		8d	94	79	72	71	67	63	61	56	54	52
	0.120		10d	107	89	81	80	76	71	69	62	60	59
	0.128		10d	121	101	93	91	86	80	79	70	69	67
	0.131	8d		127	106	97	95	90	84	82	73	72	70
	0.135		16d	135	113	103	101	96	89	88	78	76	74
	0.148	10d	20d	154	128	118	115	109	102	100	89	87	84
	0.162	16d	40d	184	154	141	138	131	122	120	106	104	101
	0.177			213	178	163	159	151	141	138	123	121	117
	0.192	20d	30d	222	185	170	166	157	147	144	128	126	120
	0.207	30d	40d	243	203	186	182	172	161	158	135	131	125
	0.225	40d		268	224	205	201	190	178	172	143	138	132
	0.244	50d	60d	276	230	211	206	196	181	175	146	141	135
3/4	0.113		8d	94	79	72	71	67	63	61	55	54	52
	0.120		10d	107	89	81	80	76	71	69	62	60	59
	0.128		10d	121	101	93	91	86	80	79	70	69	67
	0.135		16d	135	113	103	101	96	89	88	78	76	74
	0.148	10d	20d	154	128	118	115	109	102	100	89	87	84
	0.162	16d	40d	184	154	141	138	131	122	120	106	104	101
	0.177		20d	213	178	163	159	151	141	138	123	121	117

(Continued)

**TABLE B.10 (Continued)**  
**Common Wire, Box, or Sinker Nails: Reference Lateral Design Values (*Z*) for Single-Shear (Two-Member) Connections**

Side Member Thickness, <i>t<sub>s</sub></i> (in.)	Nail Diameter, <i>D</i> (in.)	Common Wire Nail		Sinker Nail	<i>G</i> = 0.55,				<i>G</i> = 0.49,		<i>G</i> = 0.46,		<i>G</i> = 0.42,		<i>G</i> = 0.37,		<i>G</i> = 0.36, Eastern Softwoods	
		20d	30d		40d	60d	Mixed Maple Southern Pine (lb)	Douglas Fir-Larch (North) (lb)	Douglas Fir-Larch (South) Hem-Fir (North) (lb)	Douglas Fir (South) Hem-Fir (North) (lb)	Spruce-Pine-Fir (lb)	Hem-Fir (lb)	Redwood (Open Grain) (lb)	Spruce-Pine-Fir (lb)	Spruce-Pine-Fir (South) Western Cedars Western Woods (lb)	Spruce-Pine-Fir (South) Western Cedars Western Woods (lb)	Spruce-Pine-Fir (South) Western Cedars Western Woods (lb)	Spruce-Pine-Fir (South) Western Cedars Western Woods (lb)
0.192	0.192	20d	30d	40d	60d	185	170	166	157	147	144	128	126	126	126	126	126	122
0.207	0.207	30d	40d	60d		203	186	182	172	161	158	140	137	137	137	137	137	133
0.225	0.225	40d				224	205	201	190	178	174	155	151	151	151	151	151	144
0.244	0.244	50d	60d			230	211	206	196	183	179	159	154	154	154	154	154	147

Source: Courtesy of the American Forest & Paper Association, Washington, DC.

<sup>a</sup> Single-shear connection.

<sup>b</sup> Italic *d* indicates that the nail length is insufficient to provide 10 times nail diameter penetration. Multiply the tabulated values by the ratio (penetration/10 × nail diameter).

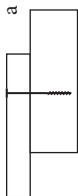


**TABLE B.11**  
**Nail and Spike Reference Withdrawal Design Values (W)**

Specific gravity, <i>G</i>	Pounds per Inch of Nail Penetration																							
	Common Wire Nails, Box Nails, and Common Wire Spikes Diameter, <i>D</i>												Common Nails/Spikes, Box Nails											
	0.099 in.	0.113 in.	0.128 in.	0.131 in.	0.135 in.	0.148 in.	0.162 in.	0.192 in.	0.207 in.	0.225 in.	0.244 in.	0.263 in.	0.283 in.	0.312 in.	0.375 in.	0.120 in.	0.135 in.	0.148 in.	0.177 in.	0.207 in.				
0.73	62	71	80	82	85	93	102	121	130	141	153	165	178	196	236	82	93	102	121	141				
0.71	58	66	75	77	79	87	95	113	121	132	143	154	166	183	220	77	87	95	113	132				
0.68	52	59	67	69	71	78	85	101	109	118	128	138	149	164	197	69	78	85	101	118				
0.67	50	57	65	66	68	75	82	97	105	114	124	133	144	158	190	66	75	82	97	114				
0.58	35	40	45	46	48	52	57	68	73	80	86	93	100	110	133	46	52	57	68	80				
0.55	31	35	40	41	42	46	50	59	64	70	76	81	88	97	116	41	46	50	59	70				
0.51	25	29	33	34	35	38	42	49	53	58	63	67	73	80	96	34	38	42	49	58				
0.50	24	28	31	32	33	36	40	47	50	55	60	64	69	76	91	32	36	40	47	55				
0.49	23	26	30	30	31	34	38	45	48	52	57	61	66	72	87	30	34	38	45	52				
0.47	21	24	27	27	28	31	34	40	43	47	51	55	59	65	78	27	31	34	40	47				
0.46	20	22	25	26	27	29	32	38	41	45	48	52	56	62	74	26	29	32	38	45				
0.44	18	20	23	23	24	26	29	34	37	40	43	47	50	55	66	23	26	29	34	40				
0.43	17	19	21	22	23	25	27	32	35	38	41	44	47	52	63	22	25	27	32	38				
0.42	16	18	20	21	21	23	26	30	33	35	38	41	45	49	59	21	23	26	30	35				
0.41	15	17	19	19	20	22	24	29	31	33	36	39	42	46	56	19	22	24	29	33				
0.40	14	16	18	18	19	21	23	27	29	31	34	37	40	44	52	18	21	23	27	31				
0.39	13	15	17	17	18	19	21	25	27	29	32	34	37	41	49	17	19	21	25	29				
0.38	12	14	16	16	17	18	20	24	25	28	30	32	35	38	46	16	18	20	24	28				
0.37	11	13	15	15	16	17	19	22	24	26	28	30	33	36	43	15	17	19	22	26				
0.36	11	12	14	14	14	16	17	21	22	24	26	28	30	33	40	14	16	17	21	24				
0.35	10	11	13	13	14	15	16	19	21	23	24	26	28	31	38	13	15	16	19	23				
0.31	7	8	9	10	10	11	12	14	15	17	18	19	21	23	28	10	11	12	14	17				

Source: Courtesy of the American Forest & Paper Association, Washington, DC.

**TABLE B.12**  
**Post-Frame Ring Shank Nails: Reference Lateral Design Values,  $Z$ , for Single-Shear (Two-Member) Connections**



Side Member Thickness $t_s$ (in.)	Nail Diameter $D$ (in.)	Nail Length $L$ (in.)	$G = 0.67$ , Red Oak		$G = 0.55$ , Mixed Maple, Southern Pine		$G = 0.5$ , Douglas Fir-Larch		$G = 0.49$ , Douglas Fir-Larch (North)		$G = 0.46$ , Douglas Fir (South), Hem-Fir (North)		$G = 0.43$ , Hem-Fir		$G = 0.42$ , Spruce-Pine-Fir		$G = 0.37$ , Redwood (Open Grain)		$G = 0.36$ , Eastern Spruce-Pine-Fir (South), Western Cedars, Western Woods		Northern Species lb
			lb	lb	lb	lb	lb	lb	lb	lb	lb	lb	lb	lb	lb	lb	lb	lb	lb		
1/2	0.135	3, 3.5	114	89	80	78	73	67	65	57	56	54									
	0.148	3-4.5	127	100	89	87	81	75	73	64	63	61									
	0.177	3-8	173	139	125	122	115	107	105	93	91	88									
	0.200	3.5-8	188	151	137	134	126	118	115	102	100	95									
3/4	0.207	4-8	193	156	142	138	131	122	119	106	102	96									
	0.135	3, 3.5	138	106	93	90	83	75	73	62	61	58									
	0.148	3-4.5	156	118	103	100	92	84	81	70	68	65									
	0.177	3-8	204	157	139	134	125	115	112	97	94	91									
1	0.200	3.5-8	218	168	149	145	135	124	121	105	103	99									
	0.207	4-8	223	173	153	149	139	128	125	109	106	103									
	0.135	3, 3.5	138	115	106	103	97	87	84	70	68	65									
	0.148	3-4.5	156	130	119	116	107	96	93	78	76	73									
	0.177	3-8	227	181	158	153	141	128	124	105	102	98									
	0.200	3.5-8	250	193	168	163	151	137	133	113	110	106									
1/4	0.207	4-8	259	197	172	166	154	140	136	116	113	109									
	0.135	3, 3.5	138	115	106	103	98	92	90	80	77	74									
	0.148	3-4.5	156	130	119	116	110	103	101	88	86	82									
	0.177	3-8	227	189	173	170	160	143	139	116	112	107									

0.200	3.5-8	250	208	191	184	169	152	147	123	120	115
0.207	4-8	259	216	195	188	172	155	150	126	123	118
0.135	3, 3.5	138	115	106	103	98	92	90	80	78	76
0.148	3-4.5	156	130	119	116	110	103	101	90	88	85
0.177	3-8	227	189	173	170	161	150	147	128	124	118
0.200	3.5-8	250	208	191	187	177	166	162	136	132	126
0.207	4-8	259	216	198	194	184	172	167	139	134	128
0.135	3, 3.5	138	115	106	103	98	92	90	80	78	76
0.148	3-4.5	156	130	119	116	110	103	101	90	88	85
0.177	3 <sup>b</sup> , 3.5 <sup>b</sup> , 4-8	227	189	173	170	161	150	147	131	128	125
0.200	3.5 <sup>b</sup> , 4-8	250	208	191	187	177	166	162	144	141	137
0.207	4-8	259	216	198	194	184	172	168	149	147	140
0.135	3.5 <sup>b</sup>	138	115	106	103	98	92	90	80	78	76
0.148	3.5 <sup>b</sup> , 4, 4.5	156	130	119	116	110	103	101	90	88	85
0.177	4 <sup>b</sup> , 4.5, 5, 6, 8	227	189	173	170	161	150	147	131	128	125
0.200	4 <sup>b</sup> , 4.5, 5, 6, 8	250	208	191	187	177	166	162	144	141	137
0.207	4 <sup>b</sup> , 4.5 <sup>b</sup> , 5, 6, 8	259	216	198	194	184	172	168	149	147	142
0.148	4.5 <sup>b</sup>	156	130	119	116	110	103	101	90	88	85
0.177	5 <sup>b</sup> , 6, 8	227	189	173	170	161	150	147	131	128	125
0.200	5 <sup>b</sup> , 6, 8	250	208	191	187	177	166	162	144	141	137
0.207	5 <sup>b</sup> , 6, 8	259	216	198	194	184	172	168	149	147	142
0.135	3, 3.5	130	111	102	100	95	89	88	78	77	75
0.148	3-4.5	142	125	115	113	107	101	99	88	87	84
0.177	3-8	171	171	167	164	156	146	143	128	126	122
0.200	3.5-8	177	177	177	177	172	161	158	141	139	135
0.207	4-8	178	178	178	178	178	167	164	146	144	140
0.135	3, 3.5	131	111	103	101	96	90	88	79	78	76
0.148	3-4.5	147	125	116	113	108	101	99	89	87	85
0.177	3-8	213	182	168	164	156	147	144	129	127	123
0.200	3.5-8	235	200	184	181	172	162	158	142	139	135
0.207	4-8	237	207	191	187	178	168	164	147	144	140

(Continued)

**TABLE B.12 (Continued)**  
**Post-Frame Ring Shank Nails: Reference Lateral Design Values,  $Z$ , for Single-Shear (Two-Member) Connections**

Side Member Thickness	Nail Diameter $D$ (in.)	Nail Length $L$ (in.)	$G = 0.67$ , Red Oak		$G = 0.55$ , Mixed Maple, Southern Pine		$G = 0.5$ , Douglas Fir-Larch		$G = 0.49$ , Douglas Fir-Larch (North)		$G = 0.46$ , Douglas Fir (South), Hem-Fir (North)		$G = 0.43$ , Hem-Fir		$G = 0.42$ , Spruce-Pine-Fir		$G = 0.37$ , Redwood (Open Grain)		$G = 0.36$ , Eastern Softwoods, Spruce-Pine-Fir (South), Western Cedars, Western Woods		$G = 0.35$ , Northern Species			
			lb	lb	lb	lb	lb	lb	lb	lb	lb	lb	lb	lb	lb	lb	lb	lb	lb	lb	lb	lb	lb	lb
0.060 (16 gage)	0.135	3, 3.5	132	113	104	102	97	92	90	81	79	77	77	77	77	77	77	77	77	77	77	77	77	
	0.148	3-4.5	148	126	117	115	109	103	101	90	89	86	86	86	86	86	86	86	86	86	86	86	86	
	0.177	3-8	214	183	169	165	157	148	145	130	128	124	124	124	124	124	124	124	124	124	124	124	124	124
	0.200	3.5-8	235	201	185	182	173	163	159	143	140	136	136	136	136	136	136	136	136	136	136	136	136	136
0.075 (14 gage)	0.207	4-8	244	208	192	188	179	168	165	148	145	141	141	141	141	141	141	141	141	141	141	141	141	141
	0.135	3, 3.5	134	115	106	104	100	94	92	83	81	79	79	79	79	79	79	79	79	79	79	79	79	79
	0.148	3-4.5	150	129	119	117	112	105	103	93	91	88	88	88	88	88	88	88	88	88	88	88	88	88
	0.177	3-8	216	185	171	167	160	150	147	132	130	126	126	126	126	126	126	126	126	126	126	126	126	126
0.105 (12 gage)	0.200	3.5-8	237	203	187	183	175	164	161	145	142	138	138	138	138	138	138	138	138	138	138	138	138	138
	0.207	4-8	246	210	194	190	181	170	167	150	147	143	143	143	143	143	143	143	143	143	143	143	143	143
	0.135	3, 3.5	142	122	113	111	106	100	98	88	87	83	83	83	83	83	83	83	83	83	83	83	83	83
	0.148	3-4.5	159	137	127	124	119	112	110	99	97	94	94	94	94	94	94	94	94	94	94	94	94	94
0.120 (11 gage)	0.177	3-8	223	192	178	174	166	157	154	138	136	132	132	132	132	132	132	132	132	132	132	132	132	132
	0.200	3.5-8	244	209	194	190	181	171	167	150	148	144	144	144	144	144	144	144	144	144	144	144	144	144
	0.207	4-8	252	216	200	196	187	176	173	155	153	148	148	148	148	148	148	148	148	148	148	148	148	148
	0.135	3, 3.5	147	127	118	115	110	104	102	92	90	86	86	86	86	86	86	86	86	86	86	86	86	86
	0.148	3-4.5	164	141	131	129	123	116	114	103	101	98	98	98	98	98	98	98	98	98	98	98	98	98
	0.177	3-8	228	197	182	179	171	161	158	142	140	136	136	136	136	136	136	136	136	136	136	136	136	136
	0.200	3.5-8	249	214	198	194	185	175	171	154	152	147	147	147	147	147	147	147	147	147	147	147	147	147
	0.207	4-8	257	221	204	200	191	180	177	159	156	152	152	152	152	152	152	152	152	152	152	152	152	152

0.134 (10 gage)	0.135	3, 3.5	152	132	122	120	115	108	106	96	93	88
	0.148	3-4.5	169	147	136	134	128	120	118	107	105	102
	0.177	3-8	234	202	187	184	175	165	162	146	144	140
	0.200	3.5-8	254	219	203	199	190	179	176	158	156	151
	0.207	4-8	262	225	209	205	196	185	181	163	160	156
0.179 (7 gage)	0.135	3, 3.5	172	149	139	136	131	123	121	105	102	98
	0.148	3-4.5	191	166	154	151	145	137	134	121	118	113
	0.177	3-8	256	222	206	202	193	183	179	162	159	153
	0.200	3.5-8	276	238	221	217	208	196	192	174	171	166
	0.207	4-8	283	245	227	223	213	201	197	178	175	170
0.239 (3 gage)	0.135	3, 3.5	184	156	144	141	134	126	124	106	102	98
	0.148	3-4.5	207	176	162	159	151	142	139	124	120	114
	0.177	3-8	293	255	236	232	220	207	203	179	174	165
	0.200	3.5-8	312	271	252	248	237	224	220	199 <sup>a</sup>	195	189
	0.207	4-8	319	277	258	253	242	229	224	203	199	194

<sup>a</sup> Single shear connection.

<sup>b</sup> Nail length is insufficient to provide 10 times nail diameter penetration. Tabulated lateral design values,  $Z$ , shall be multiplied by (penetration/10 × nail diameter).

**TABLE B.13**  
**Post-Frame Ring Shank Nail Reference Withdrawal**  
**Design Values,  $W$ , Pounds per Inch of Ring Shank**  
**Penetration into Side Grain of Wood Member**

Specific Gravity, $G$	Diameter, $D$ (in.)				
	0.135	0.148	0.177	0.200	0.207
0.73	129	142	170	192	199
0.71	122	134	161	181	188
0.68	112	123	147	166	172
0.67	109	120	143	162	167
0.58	82	90	107	121	125
0.55	74	81	96	109	113
0.51	63	69	83	94	97
0.50	61	67	80	90	93
0.49	58	64	76	86	89
0.47	54	59	70	80	82
0.46	51	56	67	76	79
0.44	47	52	62	70	72
0.43	45	49	59	67	69
0.42	43	47	56	64	66
0.41	41	45	54	61	63
0.40	39	43	51	58	60
0.39	37	41	48	55	57
0.38	35	38	46	52	54
0.37	33	36	44	49	51
0.36	31	35	41	47	48
0.35	30	33	39	44	46
0.31	23	26	31	35	36

**TABLE B.14**  
**Wood Screws: Reference Lateral Design Values (Z) for Single-Shear (Two-Member) Connections**



Side Member Thickness, $t_s$ (in.)	Wood Screw Diameter, $D$ (in.)	Wood Screw Number	G = 0.55,		G = 0.49,		G = 0.46,		G = 0.42,		G = 0.37,		G = 0.36, Eastern Softwoods Spruce-Pine-Fir (South) Western Cedars Western Woods (lb)	G = 0.35, Northern Species (lb)
			Mixed Maple Southern Pine (lb)	Douglas Fir-Larch (North) (lb)	Douglas Fir (South) Hem-Fir (North) (lb)	Hem-Fir (lb)	Spruce-Pine-Fir (lb)	Redwood (Open Grain) (lb)						
1/2	0.138	6	88	59	57	53	49	47	41	40	38			
	0.151	7	96	65	63	59	54	52	45	44	42			
	0.164	8	107	73	71	66	61	59	51	50	48			
	0.177	9	121	83	81	76	70	68	59	58	56			
	0.190	10	130	90	87	82	75	73	64	63	60			
	0.216	12	156	110	107	100	93	91	79	78	75			
	0.242	14	168	120	117	110	102	99	87	86	83			
	5/8	0.138	6	94	66	64	59	53	52	44	43	41		
		0.151	7	104	72	70	64	58	56	48	47	45		
		0.164	8	120	80	77	72	65	63	54	53	51		
		0.177	9	136	91	88	81	74	72	62	61	58		
		0.190	10	146	97	94	88	80	78	67	65	63		
		0.216	12	173	117	114	106	97	95	82	80	77		
		0.242	14	184	126	123	115	106	103	89	87	84		
3/4		0.138	6	94	72	71	65	58	57	47	46	44		
	0.151	7	104	80	77	71	64	62	52	50	48			
	0.164	8	120	88	85	78	71	69	58	56	54			

(Continued)

**TABLE B.14 (Continued)**  
**Wood Screws: Reference Lateral Design Values (Z) for Single-Shear (Two-Member) Connections**

Side Member Thickness, $t_s$ (in.)	Wood Screw Diameter, $D$ (in.)	Wood Screw Number	Reference Lateral Design Values (Z) (lb)										
			$G = 0.67$ , Red Oak	$G = 0.55$ , Mixed Maple Southern Pine	$G = 0.5$ , Douglas Fir-Larch	$G = 0.49$ , Douglas Fir-Larch	Douglas Fir (South) Hem-Fir (North)	$G = 0.43$ , Hem-Fir	$G = 0.42$ , Spruce-Pine-Fir	$G = 0.37$ , Redwood (Open Grain)	$G = 0.36$ , Eastern Softwoods Spruce-Pine-Fir (South) Western Cedars Western Woods	$G = 0.35$ , Northern Species	
1	0.177	9	142	114	99	96	88	80	78	66	64	61	
	0.190	10	153	122	107	103	95	86	83	71	69	66	
	0.216	12	192	144	126	122	113	103	100	86	84	80	
	0.242	14	203	154	135	131	122	111	108	93	91	87	
	0.138	6	94	79	72	71	67	63	61	55	54	51	
	0.151	7	104	87	80	78	74	69	68	60	59	56	
	0.164	8	120	101	92	90	85	80	78	67	65	62	
	0.177	9	142	118	108	106	100	94	90	75	73	70	
	0.190	10	153	128	117	114	108	101	97	81	78	75	
	0.216	12	193	161	147	143	131	118	114	96	93	89	
	0.242	14	213	178	157	152	139	126	122	102	100	95	
	1/4	0.138	6	94	79	72	71	67	63	61	55	54	52
		0.151	7	104	87	80	78	74	69	68	60	59	57
		0.164	8	120	101	92	90	85	80	78	70	68	66
0.177		9	142	118	108	106	100	94	92	82	80	78	
0.190		10	153	128	117	114	108	101	99	88	87	84	
0.216		12	193	161	147	144	137	128	125	108	105	100	



1½	0.242	14	213	178	163	159	151	141	138	115	111	106
	0.138	6	94	79	72	71	67	63	61	55	54	52
	0.151	7	104	87	80	78	74	69	68	60	59	57
	0.164	8	120	101	92	90	85	80	78	70	68	66
	0.177	9	142	118	108	106	100	94	92	82	80	78
	0.190	10	153	128	117	114	108	101	99	88	87	84
	0.216	12	193	161	147	144	137	128	125	111	109	106
	0.242	14	213	178	163	159	151	141	138	123	120	117
1¾	0.138	6	94	79	72	71	67	63	61	55	54	52
	0.151	7	104	87	80	78	74	69	68	60	59	57
	0.164	8	120	101	92	90	85	80	78	70	68	66
	0.177	9	142	118	108	106	100	94	92	82	80	78
	0.190	10	153	128	117	114	108	101	99	88	87	84
	0.216	12	193	161	147	144	137	128	125	111	109	106
	0.242	14	213	178	163	159	151	141	138	123	120	117

Source: Courtesy of the American Forest & Paper Association, Washington, DC.

<sup>a</sup> Single-shear connection.

**TABLE B.15**  
**Cut Thread or Rolled Thread Wood Screw Reference Withdrawal Design Values (W)**

Pounds per Inch of Thread Penetration

Specific Gravity, <i>G</i>	Wood Screw Number										
	6	7	8	9	10	12	14	16	18	20	24
0.73	209	229	249	268	288	327	367	406	446	485	564
0.71	198	216	235	254	272	310	347	384	421	459	533
0.68	181	199	216	233	250	284	318	352	387	421	489
0.67	176	193	209	226	243	276	309	342	375	409	475
0.58	132	144	157	169	182	207	232	256	281	306	356
0.55	119	130	141	152	163	186	208	231	253	275	320
0.51	102	112	121	131	141	160	179	198	217	237	275
0.50	98	107	117	126	135	154	172	191	209	228	264
0.49	94	103	112	121	130	147	165	183	201	219	254
0.47	87	95	103	111	119	136	152	168	185	201	234
0.46	83	91	99	107	114	130	146	161	177	193	224
0.44	76	83	90	97	105	119	133	148	162	176	205
0.43	73	79	86	93	100	114	127	141	155	168	196
0.42	69	76	82	89	95	108	121	134	147	161	187
0.41	66	72	78	85	91	103	116	128	141	153	178
0.40	63	69	75	81	86	98	110	122	134	146	169
0.39	60	65	71	77	82	93	105	116	127	138	161
0.38	57	62	67	73	78	89	99	110	121	131	153
0.37	54	59	64	69	74	84	94	104	114	125	145
0.36	51	56	60	65	70	80	89	99	108	118	137
0.35	48	53	57	62	66	75	84	93	102	111	130
0.31	38	41	45	48	52	59	66	73	80	87	102

*Source:* Courtesy of the American Forest & Paper Association, Washington, DC.

*Note:* Tabulated withdrawal design values (*W*) are in pounds per inch of thread penetration into side grain of main member. Thread length is approximately two-thirds the total wood screw length.

**TABLE B.16**  
**Bolts: Reference Lateral Design Values ( $Z$ ) for Single-Shear (Two-Member) Connections**



Main member, $t_m$ (in.)	Side member, $t_s$ (in.)	Bolt diameter, $D$ (in.)	$G = 0.67$ , Red Oak			$G = 0.55$ , Mixed Maple Southern Pine			$G = 0.50$ , Douglas Fir-Larch			$G = 0.49$ , Douglas Fir-Larch (North)			$G = 0.46$ , Douglas Fir (South) Hem-Fir (North)		
			$Z_{s-L}$ (lb)	$Z_{m-L}$ (lb)	$Z_{-L}$ (lb)	$Z_{s-L}$ (lb)	$Z_{m-L}$ (lb)	$Z_{-L}$ (lb)	$Z_{s-L}$ (lb)	$Z_{m-L}$ (lb)	$Z_{-L}$ (lb)	$Z_{s-L}$ (lb)	$Z_{m-L}$ (lb)	$Z_{-L}$ (lb)	$Z_{s-L}$ (lb)	$Z_{m-L}$ (lb)	$Z_{-L}$ (lb)
1/2	1/2	1/2	650	420	330	530	330	250	480	300	220	290	290	210	440	270	190
		5/8	810	500	370	660	400	280	600	360	240	350	350	240	560	320	220
		3/4	970	580	410	800	460	310	720	420	270	400	400	260	670	380	240
7/8	7/8	1	1130	660	440	930	520	330	850	470	290	460	460	280	780	420	250
		1	1290	740	470	1060	580	350	970	530	310	510	510	300	890	480	280
		1/2	760	490	390	620	390	290	560	350	250	340	340	250	520	320	230
1 3/4	5/8	5/8	940	590	430	770	470	330	700	420	280	410	410	280	650	380	250
		3/4	1130	680	480	930	540	360	850	480	310	470	470	300	780	440	280
		7/8	1320	770	510	1080	610	390	990	550	340	530	530	320	910	500	300
2 1/2	1	1	1510	860	550	1240	680	410	1130	610	360	610	600	350	1040	560	320
		1/2	770	480	340	660	400	260	610	370	240	360	360	260	580	340	220
		5/8	1070	660	450	930	560	390	850	520	340	420	420	330	780	470	300
3 1/2	3/4	3/4	1360	890	570	1120	660	430	1020	590	380	500	500	360	940	520	330
		7/8	1590	960	620	1300	720	470	1190	630	410	550	540	390	1090	550	360
		1	1820	1020	660	1490	770	490	1360	680	440	610	650	420	1250	600	390
3 1/2	1/2	1/2	770	480	340	660	400	260	610	370	240	360	360	260	580	340	220
		5/8	1070	660	450	930	560	390	850	520	340	420	420	330	780	470	300
		3/4	1450	890	570	1270	660	430	1200	590	380	510	510	360	1140	520	330
3 1/2	7/8	7/8	1890	960	620	1680	720	470	1590	630	410	550	540	390	1470	550	360
		1	2410	1020	660	2010	770	490	1830	680	440	590	650	420	1680	600	390
		1/2	830	510	340	720	400	260	670	380	240	460	460	340	620	360	220
3 1/2	5/8	5/8	1160	680	450	1000	580	400	930	530	350	560	550	450	880	500	310
		3/4	1530	900	540	1330	770	480	1250	680	460	520	520	360	1190	600	360

(Continued)

**TABLE B.16 (Continued)**  
**Bolts: Reference Lateral Design Values (Z) for Single-Shear (Two-Member) Connections**

Main member, $t_m$ (in.)	Side member, $t_s$ (in.)	Bolt diameter, $D$ (in.)	G = 0.67, Red Oak			G = 0.55, Mixed Maple Southern Pine			G = 0.50, Douglas Fir-Larch			G = 0.49, Douglas Fir-Larch (North)			G = 0.46, Douglas Fir (South) Hem-Fir (North)						
			Z <sub>sL</sub> (lb)	Z <sub>mL</sub> (lb)	Z <sub>L</sub> (lb)	Z <sub>sL</sub> (lb)	Z <sub>mL</sub> (lb)	Z <sub>L</sub> (lb)	Z <sub>sL</sub> (lb)	Z <sub>mL</sub> (lb)	Z <sub>L</sub> (lb)	Z <sub>sL</sub> (lb)	Z <sub>mL</sub> (lb)	Z <sub>L</sub> (lb)	Z <sub>sL</sub> (lb)	Z <sub>mL</sub> (lb)	Z <sub>L</sub> (lb)				
3/2	7/8	1	1970	1040	840	1730	840	810	640	1620	740	710	550	1590	700	690	530	1490	640	640	490
		1	2480	1190	1130	2030	890	880	670	1850	790	780	590	1820	750	760	570	1700	700	700	530
	3/4	1/2	830	590	530	750	520	520	460	720	490	490	430	710	480	480	420	690	460	460	410
		5/8	1290	880	880	1170	780	780	650	1120	700	700	560	1110	690	690	550	1070	650	650	500
5/4	7/8	3/4	1860	1190	1190	1690	960	960	710	1610	870	870	630	1600	850	850	600	1540	800	800	560
		1	2540	1410	1410	2170	1160	1160	780	1970	1060	1060	680	1940	1040	1040	650	1810	980	980	590
	1	1/2	3020	1670	1670	2480	1360	1360	820	2260	1230	1230	720	2210	1190	1190	690	2070	1110	1110	640
		5/8	1070	660	660	940	560	560	400	880	520	520	360	870	520	520	390	830	470	470	330
5/4	3/4	3/4	1450	890	890	1270	660	660	480	1200	590	590	430	1190	560	560	400	1140	520	520	370
		7/8	1890	960	1260	1680	720	1060	720	1590	630	940	630	1570	600	900	600	1520	550	830	550
	1	1/4	2410	1020	1500	2150	770	1140	770	2050	680	1010	680	2030	650	970	650	1930	600	910	600
		5/8	1160	680	820	1000	580	690	520	930	530	630	470	920	530	630	470	880	500	590	440
5/4	3/4	3/4	1530	900	1050	1330	770	890	680	1250	680	830	630	1240	660	810	620	1190	600	780	590
		7/8	1970	1120	1320	1730	840	1090	840	1640	740	960	740	1620	700	920	700	1550	640	850	640
	1	3/2	2480	1190	1530	2200	890	1170	890	2080	790	1040	790	2060	750	1000	750	1990	700	930	700
		5/8	1290	880	880	1170	780	780	680	1120	700	730	630	1110	690	720	620	1070	650	690	580
5/2	3/4	3/4	1860	1190	1240	1690	960	1090	850	1610	870	1030	780	1600	850	1010	750	1540	800	970	710
		7/8	2540	1410	1640	2300	1160	1380	1000	2190	1060	1230	870	2170	1040	1190	840	2060	980	1100	770
	1	1/2	3310	1670	1940	2870	1390	1520	1060	2660	1290	1360	940	2630	1260	1320	900	2500	1210	1230	830
		5/8	1070	660	760	940	560	640	500	880	520	590	460	870	520	590	450	830	470	560	430
5/2	3/4	3/4	1450	890	990	1270	660	850	660	1200	590	790	590	1190	560	780	560	1140	520	740	520
		7/8	1890	960	1260	1680	720	1090	720	1590	630	980	630	1570	600	940	600	1520	550	860	550
	1	1/2	2410	1020	1560	2150	770	1190	770	2050	680	1060	680	2030	650	1010	650	1930	600	940	600
		5/8	1160	680	820	1000	580	690	520	930	530	630	470	920	530	630	470	880	500	590	440

5/2	3 1/2	5/8	1290	880	880	780	1170	780	780	680	1120	700	730	630	1110	690	720	620	1070	650	690	580
		3/4	1860	1190	1240	1080	1690	960	1090	850	1610	870	1030	780	1600	850	1010	750	1540	800	970	710
		7/8	2540	1410	1640	1260	2300	1160	1410	1020	2190	1060	1260	910	2170	1040	1220	870	2060	980	1130	790
		1	3310	1670	1980	1470	2870	1390	1550	1100	2660	1290	1390	970	2630	1260	1340	930	2500	1210	1250	860
7/2	1 1/2	5/8	1070	660	760	590	940	560	640	500	880	520	590	460	870	520	590	450	830	470	560	430
		3/4	1450	890	990	780	1270	660	850	660	1200	590	790	590	1190	560	780	560	1140	520	740	520
		7/8	1890	960	1260	960	1680	720	1090	720	1590	630	1010	630	1570	600	990	600	1520	550	950	550
		1	2410	1020	1560	1020	2150	770	1350	770	2050	680	1270	680	2030	650	1240	650	1930	600	1190	600
7/2	3/2	5/8	1290	880	880	780	1170	780	780	680	1120	700	730	630	1110	690	720	620	1070	650	690	580
		3/4	1860	1190	1240	1080	1690	960	1090	850	1610	870	1030	780	1600	850	1010	750	1540	800	970	710
		7/8	2540	1410	1640	1260	2300	1160	1450	1020	2190	1060	1360	930	2170	1040	1340	900	2060	980	1280	850
		1	3310	1670	2090	1470	2870	1390	1830	1210	2660	1290	1630	1110	2630	1260	1570	1080	2500	1210	1470	1030

Source: Courtesy of the American Forest & Paper Association, Washington, DC.

<sup>a</sup> Single-shear connection.

**TABLE B.17**  
**Lag Screws: Reference Lateral Design Values (*Z*) for Single-Shear (Two-Member) Connections**



Side Member Thickness, $t_1$ (in.)	Lag Screw Diameter, $D$ (in.)	$G = 0.67$ , Red Oak				$G = 0.55$ , Mixed Maple Southern Pine				$G = 0.50$ , Douglas Fir-Larch				$G = 0.49$ , Douglas Fir-Larch (North)				$G = 0.46$ , Douglas Fir (South) Hem-Fir (North)							
		$Z_{s-L}$ (lb)	$Z_{m-L}$ (lb)	$Z_{-L}$ (lb)	$Z_{-L}$ (lb)	$Z_{s-L}$ (lb)	$Z_{m-L}$ (lb)	$Z_{-L}$ (lb)	$Z_{-L}$ (lb)	$Z_{s-L}$ (lb)	$Z_{m-L}$ (lb)	$Z_{-L}$ (lb)	$Z_{-L}$ (lb)	$Z_{s-L}$ (lb)	$Z_{m-L}$ (lb)	$Z_{-L}$ (lb)	$Z_{-L}$ (lb)	$Z_{s-L}$ (lb)	$Z_{m-L}$ (lb)	$Z_{-L}$ (lb)	$Z_{-L}$ (lb)				
1/2	1/4	150	110	110	110	130	90	100	90	120	90	80	80	120	90	90	80	110	80	90	80	110	80	90	80
	5/16	170	130	130	120	150	110	120	100	150	100	100	100	140	100	110	90	140	100	100	90	140	100	100	90
5/8	3/8	180	130	130	120	160	110	110	100	150	100	90	90	150	90	110	90	140	90	100	90	140	90	100	90
	1/4	160	120	130	120	140	100	110	100	130	90	90	90	130	90	100	90	120	90	100	90	120	90	90	80
3/4	5/16	190	140	140	130	160	110	120	110	150	110	100	100	150	100	110	100	150	100	110	90	150	100	110	90
	3/8	180	130	140	120	170	110	120	100	160	100	100	100	160	100	110	90	150	100	110	90	150	100	110	90
1	5/16	210	150	160	140	180	120	130	120	170	110	100	100	170	110	120	100	160	100	110	90	160	100	110	100
	3/8	210	140	160	130	180	120	130	110	170	110	100	100	170	110	120	100	160	100	110	90	160	100	110	100
1 1/4	5/16	180	140	140	140	160	120	120	120	150	120	110	110	150	110	120	100	150	110	110	90	150	110	110	100
	3/8	230	170	170	160	210	140	150	130	190	130	120	120	190	120	140	120	180	120	130	110	180	120	130	110
1 1/2	5/16	230	160	170	160	160	130	150	120	200	120	110	110	190	120	140	110	190	120	140	100	180	110	130	100
	3/8	180	140	140	140	160	120	120	120	150	120	110	110	150	110	120	100	150	110	110	90	150	110	110	100
1 3/4	5/16	230	170	170	160	210	150	150	140	200	140	130	130	200	140	140	130	200	140	140	100	180	130	140	120
	3/8	230	170	170	160	210	150	150	140	200	140	130	130	200	140	140	130	200	140	140	100	180	130	140	120
1 3/8	5/16	360	260	260	240	320	220	230	200	310	200	180	180	310	190	210	180	300	180	200	160	370	210	250	190
	3/8	460	310	320	280	410	250	290	230	390	220	200	200	390	220	260	200	370	210	250	160	460	210	250	190
1 3/4	5/8	700	410	500	370	600	340	420	310	560	310	280	280	550	310	380	270	530	290	360	260	700	210	360	260
	3/4	950	550	660	490	830	470	560	410	770	440	380	380	760	430	510	370	730	400	480	360	950	210	480	360
1 3/8	7/8	1240	720	830	630	1080	560	710	540	1020	490	490	490	1010	470	650	470	970	430	610	430	1240	210	610	430
	1	1550	800	1010	780	1360	600	870	600	1290	530	530	530	1280	500	790	500	1230	470	760	470	1550	210	760	470
1 3/4	1/4	180	140	140	140	160	120	120	120	150	120	110	110	150	110	110	110	150	110	110	90	150	110	110	100

5/16	230	170	170	160	210	150	150	140	200	140	140	130	200	140	140	190	140	140	130
3/8	230	170	170	160	210	150	150	140	200	140	140	130	200	140	140	190	140	140	120
7/16	360	260	260	240	320	230	230	210	310	210	210	190	310	210	210	190	300	200	180
1/2	460	320	320	290	410	270	290	250	390	240	270	220	390	240	260	380	220	250	200
5/8	740	440	500	400	660	360	440	320	610	330	420	290	600	320	410	570	300	390	270
3/4	1030	580	720	520	890	480	600	430	830	450	550	390	820	440	540	780	420	510	360
7/8	1320	740	890	650	1150	630	750	550	1070	570	700	510	1060	550	680	1010	500	650	470
2½	1	1630	910	1070	790	1420	700	670	1340	610	850	610	1320	590	830	1270	550	790	550
1/4	180	140	140	140	160	120	120	120	150	120	120	110	150	110	110	150	110	110	100
5/16	230	170	170	160	210	150	150	140	200	140	140	130	200	140	140	190	140	140	130
3/8	230	170	170	160	210	150	150	140	200	140	140	130	200	140	140	190	140	140	120
7/16	360	260	260	240	320	230	230	210	310	210	210	190	310	210	210	190	300	200	180
1/2	460	320	320	290	410	290	290	250	390	270	270	240	390	260	260	380	250	250	220
5/8	740	500	500	450	670	430	440	390	640	390	420	350	630	380	410	610	360	390	320
3/4	1110	680	740	610	1010	550	650	490	960	500	610	450	950	490	600	920	460	580	410
7/8	1550	830	1000	740	1370	690	880	600	1280	630	830	550	1260	620	810	1190	580	770	500
3½	1	1940	980	1270	860	1660	830	1080	1550	770	990	660	1520	750	970	1450	720	920	620
1/4	180	140	140	140	160	120	120	120	150	120	120	110	150	110	110	150	110	110	100
5/16	230	170	170	160	210	150	150	140	200	140	140	130	200	140	140	190	140	140	130
3/8	230	170	170	160	210	150	150	140	200	140	140	130	200	140	140	190	140	140	120
7/16	360	260	260	240	320	230	230	210	310	210	210	190	310	210	210	190	300	200	180
1/2	460	320	320	290	410	290	290	250	390	270	270	240	390	260	260	380	250	250	220
5/8	740	500	500	450	670	440	440	390	640	390	420	350	630	380	410	610	360	390	320
3/4	1110	680	740	610	1010	550	650	490	960	500	610	450	950	490	600	920	460	580	410
7/8	1550	830	1000	740	1370	690	880	600	1280	630	830	550	1260	620	810	1190	580	770	500
1	2020	1140	1270	1010	1830	930	1120	810	1740	850	1060	740	1730	830	1040	1670	790	1000	680

Source: Courtesy of the American Forest & Paper Association, Washington, DC.  
<sup>a</sup> Single-shear connection.

**TABLE B.18**  
**Lag Screw Reference Withdrawal Design Values (W)**

Specific Gravity, <i>G</i>	Pounds per Inch of Thread Penetration										
	Lag Screw Unthreaded Shank Diameter, <i>D</i>										
	1/4 in.	5/16 in.	3/8 in.	7/16 in.	1/2 in.	5/8 in.	3/4 in.	7/8 in.	1 in.	1 1/8 in.	1 1/4 in.
0.73	397	469	538	604	668	789	905	1016	1123	1226	1327
0.71	381	450	516	579	640	757	868	974	1077	1176	1273
0.68	357	422	484	543	600	709	813	913	1009	1103	1193
0.67	349	413	473	531	587	694	796	893	987	1078	1167
0.58	281	332	381	428	473	559	641	719	795	869	940
0.55	260	307	352	395	437	516	592	664	734	802	868
0.51	232	274	314	353	390	461	528	593	656	716	775
0.50	225	266	305	342	378	447	513	576	636	695	752
0.49	218	258	296	332	367	434	498	559	617	674	730
0.47	205	242	278	312	345	408	467	525	580	634	686
0.46	199	235	269	302	334	395	453	508	562	613	664
0.44	186	220	252	283	312	369	423	475	525	574	621
0.43	179	212	243	273	302	357	409	459	508	554	600
0.42	173	205	235	264	291	344	395	443	490	535	579
0.41	167	198	226	254	281	332	381	428	473	516	559
0.40	161	190	218	245	271	320	367	412	455	497	538
0.39	155	183	210	236	261	308	353	397	438	479	518
0.38	149	176	202	227	251	296	340	381	422	461	498
0.37	143	169	194	218	241	285	326	367	405	443	479
0.36	137	163	186	209	231	273	313	352	389	425	460
0.35	132	156	179	200	222	262	300	337	373	407	441
0.31	110	130	149	167	185	218	250	281	311	339	367

*Source:* Courtesy of the American Forest and Paper Association, Washington, DC.

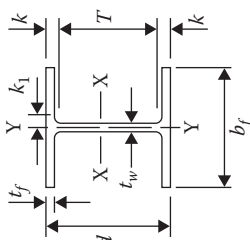
*Notes:* Tabulated withdrawal design values (*W*) are in pounds per inch of thread penetration into side grain of main member. Length of thread penetration in main member shall not include the length of the tapered tip.



---

# Appendix C: Steel

**TABLE C.1a**  
**W Shapes: Dimensions**



Shape	Area, A (in. <sup>2</sup> )	Depth, d (in.)	Web		Flange			Distance				Workable Gage (in.)
			Thickness, $t_w$ (in.)	$\frac{t_w}{2}$ (in.)	Width, $b_f$ (in.)	Thickness, $t_f$ (in.)	$k_{des}$ (in.)	$k_{det}$ (in.)	$k_1$ (in.)	T (in.)		
W21 × 93 × 83 <sup>a</sup> × 73 <sup>a</sup> × 68 <sup>a</sup> × 62 <sup>a</sup> × 55 <sup>a</sup> × 48 <sup>ab</sup> × 57 <sup>a</sup>	27.3	21.6	21 5/8	5/16	8.42	0.930	15/16	1.43	1 3/8	15/16	18 3/8	5 1/2
	24.4	21.4	21 3/8	1/4	8.36	0.835	13/16	1.34	1 1/2	7/8	18 3/8	5 1/2
	21.5	21.2	21 1/4	1/4	8.30	0.740	3/4	1.24	1 7/16	7/8	18 3/8	5 1/2
	20.0	21.1	21 1/8	1/4	8.27	0.685	11/16	1.19	1 3/8	7/8	18 3/8	5 1/2
	18.3	21.0	21	3/16	8.24	0.615	5/8	1.12	1 3/16	13/16	18 3/8	5 1/2
	16.2	20.8	20 3/4	3/8	8.22	0.522	1/2	1.02	1 3/16	13/16	18 3/8	5 1/2
	14.1	20.6	20 5/8	3/8	8.14	0.430	7/16	0.930	1 1/8	13/16	18 3/8	5 1/2
	16.7	21.1	21	3/8	8.14	0.650	5/8	1.15	1 3/16	13/16	18 3/8	5 1/2
W21 × 50 <sup>a</sup> × 44 <sup>a</sup> W18 × 311 <sup>d</sup> × 283 <sup>d</sup> × 258 <sup>d</sup> × 234 <sup>d</sup>	14.1	20.8	20	3/16	6.53	0.535	9/16	1.04	1 1/4	13/16	15 1/2	3 1/2
	13.0	20.7	20 5/8	3/8	6.50	0.450	7/16	0.950	1 1/8	13/16	15 1/2	3 1/2
	91.6	22.3	22 3/8	1 1/2	12.0	2.74	2 3/4	3.24	3 3/16	1 3/8	15 1/2	5 1/2
	83.3	21.9	21 7/8	1 3/8	11.8	2.50	2 1/2	3.00	3 3/16	1 1/4	15 1/2	5 1/2
	76.0	21.5	21 1/2	1 1/4	11.8	2.30	2 5/16	2.70	3	1 1/4	15 1/2	5 1/2
	68.8	21.1	21	1 1/16	11.7	2.11	2 1/8	2.51	2 3/4	1 3/16	15 1/2	5 1/2

× 211	62.3	20.7	20%	1.06	1 <sup>1</sup> / <sub>16</sub>	9/16	11.6	11½	1.91	1 <sup>1</sup> / <sub>16</sub>	2.31	2 <sup>1</sup> / <sub>16</sub>	1 <sup>3</sup> / <sub>16</sub>	→
× 192	56.2	20.4	20 <sup>3</sup> / <sub>8</sub>	0.960	15/16	1/2	11.5	11½	1.75	1 <sup>3</sup> / <sub>4</sub>	2.15	2 <sup>1</sup> / <sub>16</sub>	1 <sup>1</sup> / <sub>8</sub>	→
× 175	51.4	20.0	20	0.890	7/8	7/16	11.4	11 <sup>3</sup> / <sub>8</sub>	1.59	1 <sup>1</sup> / <sub>16</sub>	1.99	2 <sup>1</sup> / <sub>16</sub>	1 <sup>1</sup> / <sub>4</sub>	→
× 158	46.3	19.7	19 <sup>3</sup> / <sub>4</sub>	0.810	13/16	7/16	11.3	11¼	1.44	1 <sup>1</sup> / <sub>16</sub>	1.84	2 <sup>3</sup> / <sub>8</sub>	1 <sup>1</sup> / <sub>4</sub>	→
× 143	42.0	19.5	19½	0.730	3/4	3/8	11.2	11¼	1.32	1 <sup>1</sup> / <sub>16</sub>	1.72	2 <sup>1</sup> / <sub>16</sub>	1 <sup>3</sup> / <sub>8</sub>	→
× 130	38.3	19.3	19¼	0.670	11/16	3/8	11.2	11¼	1.20	1 <sup>3</sup> / <sub>16</sub>	1.60	2 <sup>1</sup> / <sub>16</sub>	1 <sup>3</sup> / <sub>16</sub>	→
× 119	35.1	19.0	19	0.655	5/8	5/16	11.3	11¼	1.06	1 <sup>1</sup> / <sub>16</sub>	1.46	1 <sup>5</sup> / <sub>16</sub>	1 <sup>3</sup> / <sub>16</sub>	→
× 106	31.1	18.7	18 <sup>3</sup> / <sub>4</sub>	0.590	9/16	5/16	11.2	11¼	0.940	15/16	1.34	1 <sup>5</sup> / <sub>16</sub>	1 <sup>1</sup> / <sub>8</sub>	→
× 97	28.5	18.6	18 <sup>5</sup> / <sub>8</sub>	0.535	9/16	5/16	11.1	11¼	0.870	7/8	1.27	1 <sup>3</sup> / <sub>4</sub>	1 <sup>1</sup> / <sub>8</sub>	→
× 86	25.3	18.4	18 <sup>3</sup> / <sub>8</sub>	0.480	1/2	1/4	11.1	11¼	0.770	3/4	1.17	1 <sup>5</sup> / <sub>8</sub>	1 <sup>1</sup> / <sub>16</sub>	→
× 76 <sup>a</sup>	22.3	18.2	18¼	0.425	7/16	1/4	11.0	11	0.680	11/16	1.08	1 <sup>1</sup> / <sub>16</sub>	1 <sup>1</sup> / <sub>16</sub>	→
W18 × 71	20.9	18.5	18½	0.495	1/2	1/4	7.64	7 <sup>5</sup> / <sub>8</sub>	0.810	13/16	1.21	1½	7/8	→
× 65	19.1	18.4	18 <sup>3</sup> / <sub>8</sub>	0.450	7/16	1/4	7.59	7 <sup>5</sup> / <sub>8</sub>	0.750	3/4	1.15	1 <sup>1</sup> / <sub>16</sub>	7/8	→
× 60 <sup>a</sup>	17.6	18.2	18¼	0.415	7/16	1/4	7.56	7½	0.695	11/16	1.10	1 <sup>3</sup> / <sub>8</sub>	13/16	→
× 55 <sup>a</sup>	16.2	18.1	18 <sup>1</sup> / <sub>8</sub>	0.390	3/8	3/16	7.53	7½	0.630	5/8	1.03	1 <sup>1</sup> / <sub>16</sub>	13/16	→
× 50 <sup>a</sup>	14.7	18.0	18	0.355	3/8	3/16	7.50	7½	0.570	9/16	0.972	1¼	13/16	→
W18 × 46 <sup>a</sup>	13.5	18.1	18	0.360	3/8	3/16	6.06	6	0.605	5/8	1.01	1¼	13/16	→
× 40 <sup>a</sup>	11.8	17.9	17 <sup>7</sup> / <sub>8</sub>	0.315	5/16	3/16	6.02	6	0.525	1/2	0.927	1 <sup>3</sup> / <sub>16</sub>	13/16	→
× 35 <sup>a</sup>	10.3	17.7	17¼	0.300	5/16	3/16	6.00	6	0.425	7/16	0.827	1 <sup>1</sup> / <sub>8</sub>	3/4	→
W16 × 100	29.4	17.0	17	0.585	9/16	5/16	10.4	10 <sup>5</sup> / <sub>8</sub>	0.985	1	1.39	1 <sup>7</sup> / <sub>8</sub>	1 <sup>1</sup> / <sub>8</sub>	→
× 89	26.2	16.8	16¼	0.525	1/2	1/4	10.4	10 <sup>5</sup> / <sub>8</sub>	0.875	7/8	1.28	1¼	1 <sup>1</sup> / <sub>16</sub>	→
× 77	22.6	16.5	16½	0.455	7/16	1/4	10.3	10¼	0.760	3/4	1.16	1 <sup>5</sup> / <sub>8</sub>	1 <sup>1</sup> / <sub>16</sub>	→
× 67 <sup>a</sup>	19.6	16.3	16 <sup>3</sup> / <sub>8</sub>	0.395	3/8	3/16	10.2	10¼	0.665	11/16	1.07	1 <sup>1</sup> / <sub>16</sub>	1	→
W16 × 57	16.8	16.4	16 <sup>3</sup> / <sub>8</sub>	0.430	7/16	1/4	7.12	7 <sup>7</sup> / <sub>8</sub>	0.715	11/16	1.12	1 <sup>3</sup> / <sub>8</sub>	7/8	→
× 50 <sup>a</sup>	14.7	16.3	16¼	0.380	3/8	3/16	7.07	7 <sup>7</sup> / <sub>8</sub>	0.630	5/8	1.03	1 <sup>5</sup> / <sub>16</sub>	13/16	→
× 45 <sup>a</sup>	13.3	16.1	16 <sup>1</sup> / <sub>8</sub>	0.345	3/8	3/16	7.04	7	0.565	9/16	0.967	1¼	13/16	→
× 40 <sup>a</sup>	11.8	16.0	16	0.305	5/15	3/16	7.00	7	0.505	1/2	0.907	1 <sup>3</sup> / <sub>16</sub>	13/16	→
× 36 <sup>a</sup>	10.6	15.9	15 <sup>7</sup> / <sub>8</sub>	0.295	5/16	3/16	6.99	7	0.430	7/16	0.832	1 <sup>1</sup> / <sub>8</sub>	3/4	→

(Continued)

**TABLE C.1a (Continued)**  
**W Shapes: Dimensions**

Shape	Area, A (in. <sup>2</sup> )	Depth, d (in.)	Web		Flange			Distance				Workable Cage (in.)			
			Thickness, $t_w$ (in.)	$\frac{t_w}{2}$ (in.)	Width, $b_f$ (in.)	Thickness, $t_f$ (in.)	$k_{fls}$ (in.)	$k_{det}$ (in.)	$k_1$ (in.)	T (in.)					
W16 × 31 <sup>a</sup>	9.13	15.9	15 $\frac{1}{8}$	0.275	1/4	1/8	5.53	5/2	0.440	7/16	0.842	1/8	3/4	13 $\frac{3}{8}$	3 1/2
× 26 <sup>a,c</sup>	7.68	15.7	15 $\frac{1}{4}$	0.250	1/4	1/8	5.50	5/2	0.345	3/8	0.747	1/16	3/4	13 $\frac{3}{8}$	3 1/2
W14 × 730 <sup>d</sup>	215	22.4	22 $\frac{3}{8}$	3.07	3/16	1/16	17.9	17 $\frac{3}{8}$	4.91	4 $\frac{15}{16}$	5.51	6 $\frac{3}{16}$	2/4	10	3-7 $\frac{1}{2}$ -3 <sup>e</sup>
× 665 <sup>d</sup>	196	21.6	21 $\frac{1}{8}$	2.83	2 $\frac{13}{16}$	1/16	17.7	17 $\frac{3}{8}$	4.52	4/2	5.12	5 $\frac{13}{16}$	2 $\frac{3}{8}$		3-7 $\frac{1}{2}$ -3 <sup>e</sup>
× 605 <sup>d</sup>	178	20.9	20 $\frac{3}{8}$	2.60	2 $\frac{1}{2}$	1/16	17.4	17 $\frac{3}{8}$	4.16	4 $\frac{3}{16}$	4.76	5 $\frac{1}{16}$	2 $\frac{1}{2}$		3-7 $\frac{1}{2}$ -3
× 550 <sup>d</sup>	162	20.2	20 $\frac{1}{4}$	2.38	2 $\frac{3}{8}$	1/16	17.2	17 $\frac{1}{4}$	3.82	3 $\frac{13}{16}$	4.42	5 $\frac{1}{8}$	2 $\frac{3}{8}$		
× 500 <sup>d</sup>	147	19.6	19 $\frac{3}{8}$	2.19	2 $\frac{1}{16}$	1/8	17.0	17	3.50	3/2	4.10	4 $\frac{13}{16}$	2 $\frac{5}{16}$		
× 455 <sup>d</sup>	134	19.0	19	2.02	2	1	16.8	16 $\frac{3}{8}$	3.21	3 $\frac{3}{16}$	3.81	4 $\frac{1}{2}$	2/4		
× 426 <sup>d</sup>	125	18.7	18 $\frac{3}{8}$	1.88	1 $\frac{7}{8}$	15/16	16.7	16 $\frac{3}{4}$	3.04	3/16	3.63	4 $\frac{5}{16}$	2 $\frac{1}{8}$		
× 398 <sup>d</sup>	117	18.3	18 $\frac{1}{4}$	1.77	1 $\frac{3}{4}$	7/8	16.6	16 $\frac{3}{8}$	2.85	2 $\frac{1}{8}$	3.44	4 $\frac{1}{8}$	2 $\frac{1}{8}$		
× 370 <sup>d</sup>	109	17.9	17 $\frac{3}{8}$	1.66	1 $\frac{5}{8}$	13/16	16.5	16 $\frac{1}{2}$	2.66	2 $\frac{13}{16}$	3.26	3 $\frac{15}{16}$	2 $\frac{1}{8}$		
× 342 <sup>d</sup>	101	17.5	17 $\frac{1}{2}$	1.54	1 $\frac{1}{16}$	13/16	16.4	16 $\frac{3}{8}$	2.47	2/2	3.07	3/4	2		
× 311 <sup>d</sup>	91.4	17.1	17 $\frac{1}{8}$	1.41	1 $\frac{1}{16}$	3/4	16.2	16 $\frac{1}{4}$	2.26	2/4	2.86	3 $\frac{1}{16}$	1 $\frac{15}{16}$		
× 283 <sup>d</sup>	83.3	16.7	16 $\frac{3}{4}$	1.29	1 $\frac{1}{16}$	11/16	16.1	16 $\frac{1}{8}$	2.07	2/16	2.67	3 $\frac{3}{8}$	1 $\frac{7}{8}$		
× 257	75.6	16.4	16 $\frac{3}{8}$	1.18	1 $\frac{1}{16}$	5/8	16.0	16	1.89	1 $\frac{7}{8}$	2.49	3 $\frac{3}{16}$	1 $\frac{13}{16}$		
× 233	68.5	16.0	16	1.07	1/16	9/16	15.9	15 $\frac{3}{8}$	1.72	1/4	2.32	3	1 $\frac{1}{4}$		
× 211	62.0	15.7	15 $\frac{1}{4}$	0.980	1	1/2	15.8	15 $\frac{1}{4}$	1.56	1/16	2.16	2 $\frac{7}{8}$	1 $\frac{11}{16}$		
× 193	56.8	15.5	15 $\frac{1}{2}$	0.890	7/8	7/16	15.7	15 $\frac{1}{4}$	1.44	1/16	2.04	2 $\frac{3}{4}$	1 $\frac{11}{16}$		
× 176	51.8	15.2	15 $\frac{1}{4}$	0.830	13/16	7/16	15.7	15 $\frac{3}{8}$	1.31	1/16	1.91	2 $\frac{5}{8}$	1 $\frac{5}{8}$		
× 159	46.7	15.0	15	0.745	3/4	3/8	15.6	15 $\frac{3}{8}$	1.19	1/16	1.79	2 $\frac{1}{2}$	1 $\frac{9}{16}$		
× 145	42.7	14.8	14 $\frac{3}{4}$	0.680	11/16	3/8	15.5	15 $\frac{1}{2}$	1.09	1/16	1.69	2 $\frac{3}{8}$	1 $\frac{9}{16}$		

W14 × 132	38.8	14.7	14 <sup>5</sup> / <sub>8</sub>	0.645	5/8	5/16	14.7	14 <sup>3</sup> / <sub>4</sub>	1.03	1	1.63	2 <sup>5</sup> / <sub>16</sub>	1 <sup>9</sup> / <sub>16</sub>	10	5 <sup>1</sup> / <sub>2</sub>
× 120	35.3	14.5	14 <sup>1</sup> / <sub>2</sub>	0.590	9/16	5/16	14.7	14 <sup>5</sup> / <sub>8</sub>	0.940	15/16	1.54	2 <sup>1</sup> / <sub>4</sub>	1 <sup>1</sup> / <sub>2</sub>	→	→
× 109	32.0	14.3	14 <sup>3</sup> / <sub>8</sub>	0.525	1/2	1/4	14.6	14 <sup>5</sup> / <sub>8</sub>	0.860	7/8	1.46	2 <sup>3</sup> / <sub>16</sub>	1 <sup>1</sup> / <sub>2</sub>	→	→
× 99 <sup>b</sup>	29.1	14.2	14 <sup>1</sup> / <sub>4</sub>	0.485	1/2	1/4	14.6	14 <sup>5</sup> / <sub>8</sub>	0.780	3/4	1.38	2 <sup>1</sup> / <sub>16</sub>	1 <sup>7</sup> / <sub>16</sub>	→	→
× 90 <sup>b</sup>	26.5	14.0	14	0.440	7/16	1/4	14.5	14 <sup>1</sup> / <sub>2</sub>	0.710	11/16	1.31	2	1 <sup>7</sup> / <sub>16</sub>	→	→
W14 × 82	24.0	14.3	14 <sup>1</sup> / <sub>4</sub>	0.510	1/2	1/4	10.1	10 <sup>5</sup> / <sub>8</sub>	0.855	7/8	1.45	1 <sup>11</sup> / <sub>16</sub>	1 <sup>1</sup> / <sub>16</sub>	10 <sup>7</sup> / <sub>8</sub>	5 <sup>1</sup> / <sub>2</sub>
× 74	21.8	14.2	14 <sup>1</sup> / <sub>8</sub>	0.450	7/16	1/4	10.1	10 <sup>5</sup> / <sub>8</sub>	0.785	13/16	1.38	1 <sup>5</sup> / <sub>8</sub>	1 <sup>1</sup> / <sub>16</sub>	→	→
× 68	20.0	14.0	14	0.415	7/16	1/4	10.0	10	0.720	3/4	1.31	1 <sup>1</sup> / <sub>16</sub>	1 <sup>1</sup> / <sub>16</sub>	→	→
× 61	17.9	13.9	13 <sup>3</sup> / <sub>8</sub>	0.375	3/8	3/16	10.0	10	0.645	5/8	1.24	1 <sup>1</sup> / <sub>2</sub>	1	→	→
W14 × 53	15.6	13.9	13 <sup>3</sup> / <sub>8</sub>	0.370	3/8	3/16	8.06	8	0.660	11/16	1.25	1 <sup>1</sup> / <sub>2</sub>	1	10 <sup>7</sup> / <sub>8</sub>	5 <sup>1</sup> / <sub>2</sub>
× 48	14.1	13.8	13 <sup>3</sup> / <sub>4</sub>	0.340	5/16	3/16	8.03	8	0.595	5/8	1.19	1 <sup>7</sup> / <sub>16</sub>	1	→	→
× 43 <sup>a</sup>	12.6	13.7	13 <sup>3</sup> / <sub>8</sub>	0.305	5/16	3/16	8.00	8	0.530	1/2	1.12	1 <sup>3</sup> / <sub>8</sub>	1	→	→
W14 × 38 <sup>a</sup>	11.2	14.1	14 <sup>1</sup> / <sub>8</sub>	0.310	5/16	3/16	6.77	6 <sup>3</sup> / <sub>4</sub>	0.515	1/2	0.915	1 <sup>1</sup> / <sub>4</sub>	13/16	11 <sup>5</sup> / <sub>8</sub>	3 <sup>1</sup> / <sub>2</sub>
× 34 <sup>a</sup>	10.0	14.0	14	0.285	5/16	3/16	6.75	6 <sup>3</sup> / <sub>4</sub>	0.455	7/16	0.855	1 <sup>3</sup> / <sub>16</sub>	3/4	→	→
× 30 <sup>a</sup>	8.85	13.8	13 <sup>3</sup> / <sub>8</sub>	0.270	1/4	1/8	6.73	6 <sup>3</sup> / <sub>4</sub>	0.385	3/8	0.785	1 <sup>1</sup> / <sub>8</sub>	3/4	→	→
W14 × 26 <sup>a</sup>	7.69	13.9	13 <sup>3</sup> / <sub>8</sub>	0.255	1/4	1/8	5.03	5	0.420	7/16	0.820	1 <sup>1</sup> / <sub>8</sub>	3/4	11 <sup>5</sup> / <sub>8</sub>	2 <sup>3</sup> / <sub>4</sub>
× 22 <sup>a</sup>	6.49	13.7	13 <sup>3</sup> / <sub>4</sub>	0.230	1/4	1/8	5.00	5	0.335	5/16	0.735	1 <sup>1</sup> / <sub>16</sub>	3/4	11 <sup>5</sup> / <sub>8</sub>	2 <sup>3</sup> / <sub>4</sub>
W12 × 336 <sup>d</sup>	98.9	16.8	16 <sup>6</sup> / <sub>8</sub>	1.78	1 <sup>3</sup> / <sub>4</sub>	7/8	13.4	13 <sup>3</sup> / <sub>4</sub>	2.96	2 <sup>5</sup> / <sub>16</sub>	3.55	3 <sup>3</sup> / <sub>8</sub>	1 <sup>11</sup> / <sub>16</sub>	9 <sup>3</sup> / <sub>8</sub>	5 <sup>1</sup> / <sub>2</sub>
× 305 <sup>d</sup>	89.5	16.3	16 <sup>6</sup> / <sub>8</sub>	1.63	1 <sup>5</sup> / <sub>8</sub>	13/16	13.2	13 <sup>3</sup> / <sub>4</sub>	2.71	2 <sup>1</sup> / <sub>16</sub>	3.30	3 <sup>3</sup> / <sub>8</sub>	1 <sup>3</sup> / <sub>8</sub>	→	→
× 279 <sup>d</sup>	81.9	15.9	15 <sup>7</sup> / <sub>8</sub>	1.53	1 <sup>1</sup> / <sub>2</sub>	3/4	13.1	13 <sup>3</sup> / <sub>8</sub>	2.47	2 <sup>1</sup> / <sub>2</sub>	3.07	3 <sup>3</sup> / <sub>8</sub>	1 <sup>5</sup> / <sub>8</sub>	→	→
× 252 <sup>d</sup>	74.1	15.4	15 <sup>5</sup> / <sub>8</sub>	1.40	1 <sup>3</sup> / <sub>8</sub>	11/16	13.0	13	2.25	2 <sup>1</sup> / <sub>4</sub>	2.85	3 <sup>1</sup> / <sub>8</sub>	1 <sup>1</sup> / <sub>2</sub>	→	→
× 230 <sup>d</sup>	67.7	15.1	15	1.29	1 <sup>5</sup> / <sub>16</sub>	11/16	12.9	12 <sup>7</sup> / <sub>8</sub>	2.07	2 <sup>1</sup> / <sub>16</sub>	2.67	2 <sup>5</sup> / <sub>16</sub>	1 <sup>1</sup> / <sub>2</sub>	→	→
× 210	61.8	14.7	14 <sup>3</sup> / <sub>4</sub>	1.18	1 <sup>1</sup> / <sub>16</sub>	5/8	12.8	12 <sup>3</sup> / <sub>4</sub>	1.90	1 <sup>7</sup> / <sub>8</sub>	2.50	2 <sup>13</sup> / <sub>16</sub>	1 <sup>7</sup> / <sub>16</sub>	→	→
× 190	56.0	14.4	14 <sup>3</sup> / <sub>8</sub>	1.06	1 <sup>1</sup> / <sub>16</sub>	9/16	12.7	12 <sup>5</sup> / <sub>8</sub>	1.74	1 <sup>3</sup> / <sub>4</sub>	2.33	2 <sup>5</sup> / <sub>8</sub>	1 <sup>3</sup> / <sub>8</sub>	→	→
× 170	50.0	14.0	14	0.960	15/16	1/2	12.6	12 <sup>5</sup> / <sub>8</sub>	1.56	1 <sup>9</sup> / <sub>16</sub>	2.16	2 <sup>7</sup> / <sub>16</sub>	1 <sup>3</sup> / <sub>16</sub>	→	→
× 152	44.7	13.7	13 <sup>3</sup> / <sub>4</sub>	0.870	7/8	7/16	12.5	12 <sup>1</sup> / <sub>2</sub>	1.40	1 <sup>3</sup> / <sub>8</sub>	2.00	2 <sup>5</sup> / <sub>16</sub>	1 <sup>1</sup> / <sub>4</sub>	→	→
× 136	39.9	13.4	13 <sup>3</sup> / <sub>8</sub>	0.790	13/16	7/16	12.4	12 <sup>3</sup> / <sub>8</sub>	1.25	1 <sup>1</sup> / <sub>4</sub>	1.85	2 <sup>1</sup> / <sub>8</sub>	1 <sup>1</sup> / <sub>4</sub>	→	→
× 120	35.2	13.1	13 <sup>1</sup> / <sub>8</sub>	0.710	11/16	3/8	12.3	12 <sup>3</sup> / <sub>8</sub>	1.11	1 <sup>1</sup> / <sub>8</sub>	1.70	2	1 <sup>3</sup> / <sub>16</sub>	→	→
× 106	31.2	12.9	12 <sup>7</sup> / <sub>8</sub>	0.610	5/8	5/16	12.2	12 <sup>1</sup> / <sub>4</sub>	0.990	1	1.59	1 <sup>7</sup> / <sub>8</sub>	1 <sup>1</sup> / <sub>8</sub>	→	→

(Continued)

**TABLE C.1a (Continued)**  
**W Shapes: Dimensions**

Shape	Area, A (in. <sup>2</sup> )	Depth, d (in.)	Web		Flange		Distance				Workable Gage (in.)	
			Thickness, $t_w$ (in.)	$\frac{t_w}{2}$ (in.)	Width, $b_f$ (in.)	Thickness, $t_f$ (in.)	$k_{des}$ (in.)	$k_{det}$ (in.)	$k_1$ (in.)	T (in.)		
× 96	28.2	12.7	12 <sup>3</sup> / <sub>4</sub>	5/16	12.2	12 <sup>1</sup> / <sub>2</sub>	0.900	7/8	1.50	1 <sup>3</sup> / <sub>16</sub>	1 <sup>1</sup> / <sub>2</sub>	↘
	× 87	12.5	12 <sup>1</sup> / <sub>2</sub>	1/4	12.1	12 <sup>1</sup> / <sub>2</sub>	0.810	13/15	1.41	1 <sup>1</sup> / <sub>16</sub>	1 <sup>1</sup> / <sub>2</sub>	
	× 79	12.4	12 <sup>3</sup> / <sub>4</sub>	1/4	12.1	12 <sup>1</sup> / <sub>2</sub>	0.735	3/4	1.33	1 <sup>3</sup> / <sub>8</sub>	1 <sup>1</sup> / <sub>2</sub>	
	× 72	12.3	12 <sup>1</sup> / <sub>2</sub>	1/4	12.0	12	0.670	11/16	1.27	1 <sup>1</sup> / <sub>16</sub>	1 <sup>1</sup> / <sub>2</sub>	
W12 × 58	× 65 <sup>b</sup>	12.1	12 <sup>1</sup> / <sub>2</sub>	3/16	12.0	12	0.605	5/8	1.20	1 <sup>1</sup> / <sub>2</sub>	1	↘
	× 53	17.0	12.2	3/8	10.0	10	0.640	5/8	1.24	1 <sup>1</sup> / <sub>2</sub>	15/16	5 <sup>1</sup> / <sub>2</sub>
	× 53	15.6	12.1	3/8	10.0	10	0.575	9/16	1.18	1 <sup>3</sup> / <sub>8</sub>	15/16	5 <sup>1</sup> / <sub>2</sub>
W12 × 50	14.6	12.2	12 <sup>1</sup> / <sub>4</sub>	3/16	8.08	8 <sup>1</sup> / <sub>2</sub>	0.640	5/8	1.14	1 <sup>1</sup> / <sub>2</sub>	15/16	5 <sup>1</sup> / <sub>2</sub>
	× 45	13.1	12.1	5/16	8.05	8	0.575	9/16	1.08	1 <sup>3</sup> / <sub>8</sub>	15/16	↘
× 40	11.7	11.9	12	3/16	8.01	8	0.515	1/2	1.02	1 <sup>3</sup> / <sub>8</sub>	7/8	↘
	W12 × 35 <sup>a</sup>	10.3	12.5	5/16	6.56	6 <sup>1</sup> / <sub>2</sub>	0.520	1/2	0.820	1 <sup>3</sup> / <sub>16</sub>	3/4	10 <sup>3</sup> / <sub>8</sub>
× 30 <sup>a</sup>	8.79	12.3	12 <sup>3</sup> / <sub>4</sub>	1/8	6.52	6 <sup>1</sup> / <sub>2</sub>	0.440	7/16	0.740	1 <sup>1</sup> / <sub>2</sub>	3/4	↘
	× 26 <sup>a</sup>	7.65	12.2	1/4	6.49	6 <sup>1</sup> / <sub>2</sub>	0.380	3/8	0.680	1 <sup>1</sup> / <sub>16</sub>	3/4	↘
W12 × 22 <sup>a</sup>	6.48	12.3	12 <sup>1</sup> / <sub>4</sub>	1/8	4.03	4	0.425	7/16	0.725	15/16	5/8	10 <sup>3</sup> / <sub>8</sub>
	× 19 <sup>a</sup>	5.57	12.2	1/4	4.01	4	0.350	3/8	0.650	7/8	9/16	2 <sup>1</sup> / <sub>4</sub> <sup>e</sup>
× 16 <sup>a</sup>	4.71	12.0	12	1/8	3.99	4	0.265	1/4	0.565	13/16	9/16	↘
	× 14 <sup>a,c</sup>	4.16	11.9	3/16	3.97	4	0.225	1/4	0.525	3/4	9/16	↘
W10 × 112	32.9	11.4	11 <sup>3</sup> / <sub>4</sub>	3/8	10.4	10 <sup>3</sup> / <sub>8</sub>	1.25	1 <sup>1</sup> / <sub>4</sub>	1.75	1 <sup>5</sup> / <sub>16</sub>	1	5 <sup>1</sup> / <sub>2</sub>
	× 100	29.3	11.1	11/16	10.3	10 <sup>3</sup> / <sub>8</sub>	1.12	1 <sup>1</sup> / <sub>8</sub>	1.62	1 <sup>3</sup> / <sub>16</sub>	1	↘
× 88	26.0	10.8	10 <sup>3</sup> / <sub>8</sub>	5/16	10.3	10 <sup>3</sup> / <sub>8</sub>	0.990	1	1.49	1 <sup>1</sup> / <sub>16</sub>	15/16	↘
	× 77	22.7	10.6	1/2	10.2	10 <sup>3</sup> / <sub>8</sub>	0.870	7/8	1.37	1 <sup>9</sup> / <sub>16</sub>	7/8	↘
× 68	19.9	10.4	10 <sup>3</sup> / <sub>8</sub>	1/4	10.1	10 <sup>3</sup> / <sub>8</sub>	0.770	3/4	1.27	1 <sup>7</sup> / <sub>16</sub>	7/8	↘
	× 60	17.7	10.2	7/16	10.1	10 <sup>3</sup> / <sub>8</sub>	0.680	11/16	1.18	1 <sup>3</sup> / <sub>8</sub>	13/16	↘
× 54	15.8	10.1	10 <sup>3</sup> / <sub>8</sub>	3/8	10.0	10	0.615	5/8	1.12	1 <sup>5</sup> / <sub>16</sub>	13/16	↘
	× 49	14.4	10.0	5/16	10.0	10	0.560	9/16	1.06	1 <sup>1</sup> / <sub>4</sub>	13/16	↘

W10 × 45	13.3	10.1	10%	0.350	3/8	3/16	8.02	8	0.620	5/8	1.12	1 3/16	13/16	7 1/2	5 1/2
× 39	11.5	9.92	9%	0.315	5/16	3/16	7.99	8	0.530	1/2	1.03	1 3/16	13/16	7 1/2	5 1/2
× 33	9.71	9.73	9 3/4	0.290	5/16	3/16	7.96	8	0.435	7/16	0.935	1 1/8	3/4	8 3/4	2 3/4 <sup>e</sup>
W10 × 30	8.84	10.5	10 1/2	0.300	5/16	3/16	5.81	5 3/4	0.510	1/2	0.810	1 1/8	11/16	8 3/4	2 3/4 <sup>e</sup>
× 26	7.61	10.3	10 3/8	0.260	1/4	1/8	5.77	5 3/4	0.440	7/16	0.740	1 1/16	11/16	8 3/4	2 3/4 <sup>e</sup>
× 22 <sup>a</sup>	6.49	10.2	10%	0.240	1/4	1/8	5.75	5 3/4	0.360	3/8	0.660	15/16	5/8	8 3/4	2 3/4 <sup>e</sup>
W10 × 19	5.62	10.2	10 1/4	0.250	1/4	1/8	4.02	4	0.395	3/8	0.695	15/16	5/8	8 3/4	2 3/4 <sup>e</sup>
× 17 <sup>a</sup>	4.99	10.1	10%	0.240	1/4	1/8	4.01	4	0.330	5/16	0.630	7/8	9/16	8 3/4	2 3/4 <sup>e</sup>
× 15 <sup>a</sup>	4.41	10.0	10	0.230	1/4	1/8	4.00	4	0.270	1/4	0.570	13/16	9/16	8 3/4	2 3/4 <sup>e</sup>
× 12 <sup>ab</sup>	3.54	9.87	9%	0.190	3/16	1/8	3.96	4	0.210	3/16	0.510	3/4	9/16	8 3/4	2 3/4 <sup>e</sup>

Source: Courtesy of the American Institute of Steel Construction, Chicago, Illinois.

<sup>a</sup> Shape is slender for compression with  $F_y = 50$  ksi.

<sup>b</sup> Shape exceeds compact limit for flexure with  $F_y = 50$  ksi.

<sup>c</sup> The actual size, combination, and orientation of fastener components should be compared with the geometry of the cross section to ensure compatibility.

<sup>d</sup> Flange thickness is greater than 2 in. Special requirements may apply per AISC Specification Section A3.1c.

<sup>e</sup> Shape does not meet the  $h/t_w$  limit for shear in Specification Section G2.1a with  $F_y = 50$  ksi.

**TABLE C.1b**  
**W Shapes Properties**

Shape	Compact Section Criteria		Axis x-x				Axis y-y				Torsional Properties			
	$\frac{b_f}{2t_f}$	$\frac{h}{t_w}$	$I$ (in. <sup>4</sup> )	$S$ (in. <sup>3</sup> )	$r$ (in.)	$Z$ (in. <sup>3</sup> )	$I$ (in. <sup>4</sup> )	$S$ (in. <sup>3</sup> )	$r$ (in.)	$Z$ (in. <sup>3</sup> )	$r_{ts}$ (in.)	$h_o$ (in.)	$J$ (in. <sup>4</sup> )	$C_w$ (in. <sup>6</sup> )
W21 × 93	4.53	32.3	2,070	192	8.70	221	92.9	22.1	1.84	34.7	2.24	20.7	6.03	9,940
× 83	5.00	36.4	1,830	171	8.67	196	81.4	19.5	1.83	30.5	2.21	20.6	4.34	8,630
× 73	5.60	41.2	1,600	151	8.64	172	70.6	17.0	1.81	26.6	2.19	20.5	3.02	7,410
× 68	6.04	43.6	1,480	140	8.60	160	64.7	15.7	1.80	24.4	2.17	20.4	2.45	6,760
× 62	6.70	46.9	1,330	127	8.54	144	57.5	14.0	1.77	21.7	2.15	20.4	1.83	5,960
× 55	7.87	50.0	1,140	110	8.40	126	48.4	11.8	1.73	18.4	2.11	20.3	1.24	4,980
× 48	9.47	53.6	959	93.0	8.24	107	38.7	9.52	1.66	14.9	2.05	20.2	0.803	3,950
W21 × 57	5.04	46.3	1,170	111	8.36	129	30.6	9.35	1.35	14.8	1.68	20.5	1.77	3,190
× 50	6.10	49.4	984	94.5	8.18	110	24.9	7.64	1.30	12.2	1.64	20.3	1.14	2,570
× 44	7.22	53.6	843	81.6	8.06	95.4	20.7	6.37	1.26	10.2	1.60	20.3	0.770	2,110
W18 × 311	2.19	10.4	6,970	624	8.72	754	795	132	2.95	207	3.53	19.6	176	76,200
× 283	2.38	11.3	6,170	565	8.61	676	704	118	2.91	185	3.47	19.4	134	65,900
× 258	2.56	12.5	5,510	514	8.53	611	628	107	2.88	166	3.42	19.2	103	57,600
× 234	2.76	13.8	4,900	466	8.44	549	558	95.8	2.85	149	3.37	19.0	78.7	50,100
× 211	3.02	15.1	4,330	419	8.35	490	493	85.3	2.82	132	3.32	18.8	58.6	43,400
× 192	3.27	16.7	3,870	380	8.28	442	440	76.8	2.79	119	3.28	18.6	44.7	38,000
× 175	3.58	18.0	3,450	344	8.20	398	391	68.8	2.76	106	3.24	18.4	33.8	33,300



× 158	3.92	19.8	3,060	310	8.12	356	347	61.4	2.74	94.8	3.20	18.3	25.2	29,000
× 143	4.25	22.0	2,750	282	8.09	322	311	55.5	2.72	85.4	3.17	18.2	19.2	25,700
× 130	4.65	23.9	2,460	256	8.03	290	278	49.9	2.70	76.7	3.13	18.1	14.5	22,700
× 119	5.31	24.5	2,190	231	7.90	262	253	44.9	2.69	69.1	3.13	17.9	10.6	20,300
× 106	5.96	27.2	1,910	204	7.84	230	220	39.4	2.66	60.5	3.10	17.8	7.48	17,400
× 97	6.41	30.0	1,750	188	7.82	211	201	36.1	2.65	55.3	3.08	17.7	5.86	15,800
× 86	7.20	33.4	1,530	166	7.77	186	175	31.6	2.63	48.4	3.05	17.6	4.10	13,600
× 76	8.11	37.8	1,330	146	7.73	163	152	27.6	2.61	42.2	3.02	17.5	2.83	11,700
W18 × 71	4.71	32.4	1,170	127	7.50	146	60.3	15.8	1.70	24.7	2.05	17.7	3.49	4,700
× 65	5.06	35.7	1,070	117	7.49	133	54.8	14.4	1.69	22.5	2.03	17.6	2.73	4,240
× 60	5.44	38.7	984	108	7.47	123	50.1	13.3	1.68	20.6	2.02	17.5	2.17	3,850
× 55	5.98	41.1	890	98.3	7.41	112	44.9	11.9	1.67	18.5	2.00	17.5	1.66	3,430
× 50	6.57	45.2	800	88.9	7.38	101	40.1	10.7	1.65	16.6	1.98	17.4	1.24	3,040
W18 × 46	5.01	44.6	712	78.8	7.25	90.7	22.5	7.43	1.29	11.7	1.58	17.5	1.22	1,720
× 40	5.73	50.9	612	68.4	7.21	78.4	19.1	6.35	1.27	10.0	1.56	17.4	0.810	1,440
× 35	7.06	53.5	510	57.6	7.04	66.5	15.3	5.12	1.22	8.06	1.51	17.3	0.506	1,140
× 100	5.29	24.3	1,490	175	7.10	198	186	35.7	2.51	54.9	2.92	16.0	7.73	11,900
× 89	5.92	27.0	1,300	155	7.05	175	163	31.4	2.49	48.1	2.88	15.9	5.45	10,200
× 77	6.77	31.2	1,110	134	7.00	150	138	26.9	2.47	41.1	2.85	15.7	3.57	8,590
× 67	7.70	35.9	954	117	6.96	130	119	23.2	2.46	35.5	2.82	15.6	2.39	7,300
W16 × 57	4.98	33.0	758	92.2	6.72	105	43.1	12.1	1.60	18.9	1.92	15.7	2.22	2,660
× 50	5.61	37.4	659	81.0	6.68	92.0	37.2	10.5	1.59	16.3	1.89	15.7	1.52	2,270
× 45	6.23	41.1	586	72.7	6.65	82.3	32.8	9.34	1.57	14.5	1.87	15.5	1.11	1,990
× 40	6.93	46.5	518	64.7	6.63	73.0	28.9	8.25	1.57	12.7	1.86	15.5	0.794	1,730
× 36	8.12	48.1	448	56.5	6.51	64.0	24.5	7.00	1.52	10.8	1.83	15.5	0.545	1,460
W16 × 31	6.28	51.6	375	47.2	6.41	54.0	12.4	4.49	1.17	7.03	1.42	15.5	0.461	739
× 26	7.97	56.8	301	38.4	6.26	44.2	9.59	3.49	1.12	5.48	1.38	15.4	0.262	565
W14 × 730	1.82	3.71	14,300	1280	8.17	1660	4720	527	4.69	816	5.68	17.5	1450	362,000
× 665	1.95	4.03	12,400	1150	7.98	1480	4170	472	4.62	730	5.57	17.1	1120	305,000
× 605	2.09	4.39	10,800	1040	7.80	1320	3680	423	4.55	652	5.44	16.7	869	258,000
× 550	2.25	4.79	9,430	931	7.63	1180	3250	378	4.49	583	5.35	16.4	669	219,000
× 500	2.43	5.21	8,210	838	7.48	1050	2880	339	4.43	522	5.26	16.1	514	187,000

(Continued)

**TABLE C.1b (Continued)**  
**W Shapes Properties**

Shape	Compact Section Criteria			Axis x-x			Axis y-y			Torsional Properties					
	$\frac{b_f}{2t_f}$	$\frac{h}{t_w}$		$I$ (in. <sup>4</sup> )	$S$ (in. <sup>3</sup> )	$r$ (in.)	$Z$ (in. <sup>3</sup> )	$I$ (in. <sup>4</sup> )	$S$ (in. <sup>3</sup> )	$r$ (in.)	$Z$ (in. <sup>3</sup> )	$r_{ts}$ (in.)	$h_0$ (in.)	$J$ (in. <sup>4</sup> )	$C_w$ (in. <sup>6</sup> )
× 455	2.62	5.66		7,190	756	7.33	936	2560	304	4.38	468	5.17	15.8	395	160,000
× 426	2.75	6.08		6,600	706	7.26	869	2360	283	4.34	434	5.11	15.7	331	144,000
× 398	2.92	6.44		6,000	656	7.16	801	2170	262	4.31	402	5.05	15.5	273	129,000
× 370	3.10	6.89		5,440	607	7.07	736	1990	241	4.27	370	5.00	15.2	222	116,000
× 342	3.31	7.41		4,900	558	6.98	672	1810	221	4.24	338	4.95	15.0	178	103,000
× 311	3.59	8.09		4,330	506	6.88	603	1610	199	4.20	304	4.87	14.8	136	89,100
× 283	3.89	8.84		3,840	459	6.79	542	1440	179	4.17	274	4.80	14.6	104	77,700
× 257	4.23	9.71		3,400	415	6.71	487	1290	161	4.13	246	4.75	14.5	79.1	67,800
× 233	4.62	10.7		3,010	375	6.63	436	1150	145	4.10	221	4.69	14.3	59.5	59,000
× 211	5.06	11.6		2,660	338	6.55	390	1030	130	4.07	198	4.64	14.1	44.6	51,500
× 193	5.45	12.8		2,400	310	6.50	355	931	119	4.05	180	4.59	14.1	34.8	45,900
× 176	5.97	13.7		2,140	281	6.43	320	838	107	4.02	163	4.55	13.9	26.5	40,500
× 159	6.54	15.3		1,900	254	6.38	287	748	96.2	4.00	146	4.51	13.8	19.7	35,600
× 145	7.11	16.8		1,710	232	6.33	260	677	87.3	3.98	133	4.47	13.7	15.2	31,700
W14 × 132	7.15	17.7		1,530	209	6.28	234	548	74.5	3.76	113	4.23	13.7	12.3	25,500
× 120	7.80	19.3		1,380	190	6.24	212	495	67.5	3.74	102	4.20	13.6	9.37	22,700
× 109	8.49	21.7		1,240	173	6.22	192	447	61.2	3.73	92.7	4.17	13.4	7.12	20,200
× 99	9.34	23.5		1,110	157	6.17	173	402	55.2	3.71	83.6	4.14	13.4	5.37	18,000
× 90	10.2	25.9		999	143	6.14	157	362	49.9	3.70	75.6	4.11	13.3	4.06	16,000
W14 × 82	5.92	22.4		881	123	6.05	139	148	29.3	2.48	44.8	2.85	13.4	5.07	6,710
× 74	6.41	25.4		795	112	6.04	126	134	26.6	2.48	40.5	2.82	13.4	3.87	5,990
× 68	6.97	27.5		722	103	6.01	115	121	24.2	2.46	36.9	2.80	13.3	3.01	5,380
× 61	7.75	30.4		640	92.1	5.98	102	107	21.5	2.45	32.8	2.78	13.3	2.19	4,710
W14 × 53	6.11	30.9		541	77.8	5.89	87.1	57.7	14.3	1.92	22.0	2.22	13.2	1.94	2,540
× 48	6.75	33.6		484	70.2	5.85	78.4	51.4	12.8	1.91	19.6	2.20	13.2	1.45	2,240
× 43	7.54	37.4		428	62.6	5.82	69.6	45.2	11.3	1.89	17.3	2.18	13.2	1.05	1,950
W14 × 38	6.57	39.6		385	54.6	5.87	61.5	26.7	7.88	1.55	12.1	1.82	13.6	0.798	1,230

× 34	7.41	43.1	340	48.6	5.83	54.6	23.3	6.91	1.53	10.6	1.80	13.5	0.569	1,070
× 30	8.74	45.4	291	42.0	5.73	47.3	19.6	5.82	1.49	8.99	1.77	13.4	0.380	887
W14 × 26	5.98	48.1	245	35.3	5.65	40.2	8.91	3.55	1.08	5.54	1.31	13.5	0.358	405
22	7.46	53.3	199	29.0	5.54	33.2	7.00	2.80	1.04	4.39	1.27	134	0.208	314
W12 × 336	2.26	5.47	4,060	483	6.41	603	1190	177	3.47	274	4.13	13.8	243	57,000
× 305	2.45	5.98	3,550	435	6.29	537	1050	159	3.42	244	4.05	13.6	185	48,600
× 279	2.66	6.35	3,110	393	6.16	481	937	143	3.38	220	4.00	13.4	143	42,000
× 252	2.89	6.96	2,720	353	6.06	428	828	127	3.34	196	3.93	13.2	108	35,800
× 230	3.11	7.56	2,420	321	5.97	386	742	115	3.31	177	3.87	13.0	83.8	31,200
× 210	3.37	8.23	2,140	29.2	5.89	348	664	104	3.28	159	3.82	12.8	64.7	27,200
× 190	3.65	9.16	1,890	263	5.82	311	589	93.0	3.25	143	3.76	12.7	48.8	23,600
× 170	4.03	10.1	1,650	235	5.74	275	517	82.3	3.22	126	3.71	12.4	35.6	20,100
× 152	4.46	11.2	1,430	209	5.66	243	454	72.8	3.19	111	3.66	12.3	25.8	17,200
× 136	4.96	12.3	1,240	186	5.58	214	398	64.2	3.16	98.0	3.61	12.2	18.5	14,700
× 120	5.57	13.7	1,070	163	5.51	186	345	56.0	3.13	85.4	3.56	12.0	12.9	12,400
× 106	6.17	15.9	933	145	5.47	164	301	49.3	3.11	75.1	3.52	11.9	9.13	10,700
× 96	6.76	17.7	833	131	5.44	147	270	44.4	3.09	67.5	3.49	11.8	6.85	9,410
× 87	7.48	18.9	740	118	5.38	132	241	39.7	3.07	60.4	3.46	11.7	5.10	8,270
× 79	8.22	20.7	662	107	5.34	119	216	35.8	3.05	54.3	3.43	11.7	3.84	7,330
× 72	8.99	22.6	597	97.4	5.31	108	195	32.4	3.04	49.2	3.40	11.6	2.93	6,540
× 65	9.92	24.9	533	87.9	5.28	96.8	174	29.1	3.02	44.1	3.38	11.5	2.18	5,780
W12 × 58	7.82	27.0	475	78.0	5.28	86.4	107	21.4	2.51	32.5	2.82	11.6	2.10	3,570
× 53	8.69	28.1	425	70.6	5.23	77.9	95.8	19.2	2.48	29.1	2.79	11.5	1.58	3,160
W12 × 50	6.31	26.8	391	64.2	5.18	71.9	56.3	13.9	1.96	21.3	2.25	11.6	1.71	1,880
× 45	7.00	29.6	348	57.7	5.15	64.2	50.0	12.4	1.95	19.0	2.23	11.5	1.26	1,650
× 40	7.77	33.6	307	51.5	5.13	37.0	44.1	11.0	1.94	16.8	2.21	11.4	0.906	1,440
W12 × 35	6.31	36.2	285	45.6	5.25	51.2	24.5	7.47	1.54	11.5	1.79	12.0	0.741	879
× 30	7.41	41.8	238	38.6	5.21	43.1	20.3	6.24	1.52	9.56	1.77	11.9	0.457	720
× 26	8.54	47.2	204	33.4	5.17	37.2	17.3	5.34	1.51	8.17	1.75	11.8	0.300	607
W12 × 22	4.74	41.8	156	25.4	4.91	29.3	4.66	2.31	0.848	3.66	1.04	11.9	0.293	164
× 19	5.72	46.2	130	21.3	4.82	24.7	3.76	1.88	0.822	2.98	1.02	11.9	0.180	131
× 16	7.53	49.4	103	17.1	4.67	20.1	2.82	1.41	0.773	2.26	0.983	11.7	0.103	96.9
× 14	8.82	54.3	88.6	14.9	4.62	17.4	2.36	1.19	0.753	1.90	0.961	11.7	0.0704	80.4

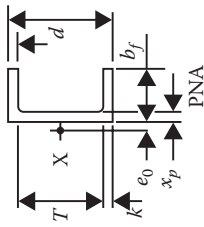
(Continued)

**TABLE C.1b (Continued)**  
**W Shapes Properties**

Shape	Compact Section Criteria		Axis x-x				Axis y-y				Torsional Properties			
	$\frac{b_f}{2t_f}$	$\frac{h}{t_w}$	$I$ (in. <sup>4</sup> )	$S$ (in. <sup>3</sup> )	$r$ (in.)	$Z$ (in. <sup>3</sup> )	$I$ (in. <sup>4</sup> )	$S$ (in. <sup>3</sup> )	$r$ (in.)	$Z$ (in. <sup>3</sup> )	$r_s$ (in.)	$h_o$ (in.)	$J$ (in. <sup>4</sup> )	$C_w$ (in. <sup>6</sup> )
W10 × 112	4.17	10.4	716	126	4.66	147	236	45.3	2.68	69.2	3.08	10.2	15.1	6,020
× 100	4.62	11.6	623	112	4.60	130	207	40.0	2.65	61.0	3.04	10.0	10.9	5,150
× 88	5.18	13.0	534	98.5	4.54	113	179	34.8	2.63	53.1	2.99	9.81	7.53	4,330
× 77	5.86	14.8	455	85.9	4.49	97.6	154	30.1	2.60	45.9	2.95	9.73	5.11	3,630
× 68	6.58	16.7	394	75.7	4.44	85.3	134	26.4	2.59	40.1	2.92	9.63	3.56	3,100
× 60	7.41	18.7	341	66.7	4.39	74.6	116	23.0	2.57	35.0	2.88	9.52	2.48	2,640
× 54	8.15	21.2	303	60.0	4.37	66.6	103	20.6	2.56	31.3	2.85	9.49	1.82	2,320
× 49	8.93	23.1	272	54.6	4.35	60.4	93.4	18.7	2.54	28.3	2.84	9.44	1.39	2,070
W10 × 45	6.47	22.5	248	49.1	4.32	54.9	53.4	13.3	2.01	20.3	2.27	9.48	1.51	1,200
× 39	7.53	25.0	209	42.1	4.27	46.8	45.0	11.3	1.98	17.2	2.24	9.39	0.976	992
× 33	9.15	27.1	171	35.0	4.19	38.8	36.6	9.20	1.94	14.0	2.20	9.30	0.583	791
W10 × 30	5.70	29.5	170	32.4	4.38	36.6	16.7	5.75	1.37	8.84	1.60	10.0	0.622	414
× 26	6.56	34.0	144	27.9	4.35	31.3	14.1	4.89	1.36	7.50	1.58	9.86	0.402	345
× 22	7.99	36.9	118	23.2	4.27	26.0	11.4	3.97	1.33	6.10	1.55	9.84	0.239	275
W30 × 19	5.09	35.4	96.3	18.8	4.14	21.6	4.29	2.14	0.874	3.35	1.06	9.81	0.233	104
× 17	6.08	36.9	81.9	16.2	4.05	18.7	3.56	1.78	0.845	2.80	1.04	9.77	0.156	85.1
× 15	7.41	38.5	68.9	13.8	3.95	16.0	2.89	1.45	0.810	2.30	1.01	9.72	0.104	68.3
× 12	9.43	46.6	53.8	10.9	3.90	12.6	2.18	1.10	0.785	1.74	0.983	9.66	0.0547	50.9

Source: Courtesy of the American Institute of Steel Construction, Chicago, Illinois.

**TABLE C.2a**  
**C Shapes Dimensions**



Shape	Area, A (in. <sup>2</sup> )	Web			Flange			Distance			$r_s$ (in.)	$h_o$ (in.)
		Depth, $d$ (in.)	Thickness, $t_w$ (in.)	$\frac{t_w}{\gamma}$ (in.)	Width, $b_f$ (in.)	Thickness, $t_f$ (in.)	$k$ (in.)	$T$ (in.)	Workable Gage (in.)			
C15 × 50	14.7	15.0	0.716	3/8	3.72	5/8	1 7/16	12 1/8	2 1/4	1.17	14.4	
× 40	11.8	15.0	0.520	1/2	3.52	5/8	1 7/16	12 1/8	2	1.15	14.4	
× 33.9	10.0	15.0	0.400	3/16	3.40	5/8	1 7/16	12 1/8	2	1.13	14.4	
C12 × 30	8.81	12.0	0.510	1/2	3.17	1/2	1 1/8	9 3/4	1 3/4	1.01	11.5	
× 25	7.34	12.0	0.387	3/8	3.05	1/2	1 1/8	9 3/4	1 3/4	1.00	11.5	
× 20.7	6.08	12.0	0.282	5/16	2.94	1/2	1 1/8	9 3/4	1 3/4	0.983	11.5	
C10 × 30	8.81	10.0	0.673	11/16	3.03	7/16	1	8	1 3/4	0.924	9.56	
× 25	7.35	10.0	0.526	1/2	2.89	7/16	1	8	1 3/4	0.911	9.56	
× 20	5.87	10.0	0.379	3/8	2.74	7/16	1	8	1 1/2	0.894	9.56	
× 15.3	4.48	10.0	0.240	1/4	2.60	7/16	1	8	1 1/2	0.868	9.56	
C9 × 20	5.87	9.00	0.448	7/16	2.65	7/16	1	7	1 1/2	0.850	8.59	
× 15	4.40	9.00	0.285	5/16	2.49	7/16	1	7	1 3/8	0.825	8.59	
× 13.4	3.94	9.00	0.233	1/4	2.43	7/16	1	7	1 3/8	0.814	8.59	
C8 × 18.7	5.51	8.00	0.487	1/2	2.53	3/8	15/16	6 1/8	1 1/2	0.800	7.61	
× 13.7	4.03	8.00	0.303	5/16	2.34	3/8	15/16	6 1/8	1 3/8	0.774	7.61	
× 11.5	3.37	8.00	0.220	1/4	2.26	3/8	15/16	6 1/8	1 3/8	0.756	7.61	

(Continued)

**TABLE C.2b (Continued)**  
**C Shapes Dimensions**

Shape	Area, <i>A</i> (in. <sup>2</sup> )	Web			Flange			Distance			<i>r<sub>s</sub></i> (in.)	<i>h<sub>o</sub></i> (in.)
		Thickness, <i>t<sub>w</sub></i> (in.)	$\frac{t_w}{2}$ (in.)	Depth, <i>d</i> (in.)	Width, <i>b<sub>f</sub></i> (in.)	Thickness, <i>t<sub>f</sub></i> (in.)	<i>k</i> (in.)	<i>T</i> (in.)	Workable Gage (in.)			
C7 × 14.7	4.33	0.419	1/4	7	2.30	3/8	7/8	5/4	1/4 <sup>a</sup>	0.738	6.63	
× 12.2	3.59	0.314	3/16	7	2.19	3/8	7/8	5/4	1/4 <sup>a</sup>	0.722	6.63	
× 9.8	2.87	0.210	1/8	7	2.09	3/8	7/8	5/4	1/4 <sup>a</sup>	0.698	6.63	
C6 × 13	3.82	0.437	1/4	6	2.16	5/16	13/16	4/8	1 3/8 <sup>a</sup>	0.689	5.66	
× 10.5	3.07	0.314	3/16	6	2.03	5/16	13/16	4 3/4	1 1/8 <sup>a</sup>	0.669	5.66	
× 8.2	2.39	0.200	1/8	6	1.92	5/16	13/16	4 3/4	1 1/8 <sup>a</sup>	0.643	5.66	
C5 × 9	2.64	0.325	3/16	5	1.89	5/16	3/4	3 1/2	1 1/8 <sup>a</sup>	0.616	4.68	
× 6.7	1.97	0.190	1/8	5	1.75	5/16	3/4	3 1/2	— <sup>b</sup>	0.584	4.68	
C4 × 7.2	2.13	0.321	3/16	4	1.72	5/16	3/4	2 1/2	1 <sup>a</sup>	0.563	3.70	
C4 × 6.25	1.77	0.247	1/4	4	1.65	5/16	3/4	2 1/2	— <sup>b</sup>	0.546	3.73	
× 5.4	1.58	0.184	3/16	4	1.58	5/16	3/4	2 1/2	— <sup>b</sup>	0.528	3.70	
× 4.5	1.38	0.125	1/8	4	1.58	5/16	3/4	2 1/2	— <sup>b</sup>	0.524	3.70	
C3 × 6	1.76	0.356	3/8	3	1.60	1/4	11/16	1 5/8	— <sup>b</sup>	0.519	2.73	
× 5	1.47	0.258	1/4	3	1.50	1/4	11/16	1 5/8	— <sup>b</sup>	0.496	2.73	
× 4.1	1.20	0.170	3/16	3	1.41	1/4	11/16	1 5/8	— <sup>b</sup>	0.469	2.73	
× 3.5	1.09	0.132	1/8	3	1.37	1/4	11/16	1 5/8	— <sup>b</sup>	0.456	2.73	

Source: Courtesy of the American Institute of Steel Constructors, Chicago, Illinois.

<sup>a</sup> The actual size, combination, and orientation of fastener components should be compared with the geometry of the cross section to ensure compatibility.

<sup>b</sup> Flange is too narrow to establish a workable gage.

**TABLE C.2b**  
**C Shapes Properties**

Shape	Shear Center, $e_p$ (in.)	Axis x-x				Axis y-y				Torsional Properties					
		$I$ (in. <sup>4</sup> )	$S$ (in. <sup>3</sup> )	$r$ (in.)	$Z$ (in. <sup>3</sup> )	$I$ (in. <sup>4</sup> )	$S$ (in. <sup>3</sup> )	$r$ (in.)	$\bar{x}$ (in.)	$Z$ (in. <sup>3</sup> )	$x_p$ (in.)	$J$ (in. <sup>4</sup> )	$C_w$ (in. <sup>6</sup> )	$\bar{r}_p$ (in.)	$H$
C15 × 50	0.583	404	53.8	5.24	68.5	11.0	3.77	0.865	0.799	8.14	0.490	2.65	492	5.49	0.937
× 40	0.767	348	46.5	5.43	57.5	9.17	3.34	0.883	0.778	6.84	0.392	1.45	410	5.71	0.927
× 33.9	0.896	315	42.0	5.61	50.8	8.07	3.09	0.901	0.788	6.19	0.332	1.01	358	5.94	0.920
C12 × 30	0.618	162	27.0	4.29	33.8	5.12	2.05	0.762	0.674	4.32	0.367	0.861	151	4.54	0.919
× 25	0.746	144	24.0	4.43	29.4	4.45	1.87	0.779	0.674	3.82	0.306	0.538	130	4.72	0.909
× 20.7	0.870	129	21.5	4.61	25.6	3.86	1.72	0.797	0.698	3.47	0.253	0.369	112	4.93	0.899
C10 × 30	0.368	103	20.7	3.43	26.7	3.93	1.65	0.668	0.649	3.78	0.441	1.22	79.5	3.63	0.921
× 25	0.494	91.1	18.2	3.52	23.1	3.34	1.47	0.675	0.617	3.18	0.367	0.687	68.3	3.76	0.912
× 20	0.636	78.9	15.8	3.67	19.4	2.80	1.31	0.690	0.606	2.70	0.294	0.368	56.9	3.93	0.900
× 15.3	0.796	67.3	13.5	3.88	15.9	2.27	1.15	0.711	0.634	2.34	0.224	0.209	45.5	4.19	0.884
C9 × 20	0.515	60.9	13.5	3.22	16.9	2.41	1.17	0.640	0.583	2.46	0.326	0.427	39.4	3.46	0.899
× 15	0.681	51.0	11.3	3.40	13.6	1.91	1.01	0.659	0.586	2.04	0.245	0.208	31.0	3.69	0.882
× 13.4	0.742	47.8	10.6	3.48	12.6	1.75	0.954	0.666	0.601	1.94	0.219	0.168	28.2	3.79	0.875
C8 × 18.7	0.431	43.9	11.0	2.82	13.9	1.97	1.01	0.598	0.565	2.17	0.344	0.434	25.1	3.05	0.894
× 13.7	0.604	36.1	9.02	2.99	11.0	1.52	0.848	0.613	0.554	1.73	0.252	0.186	19.2	3.26	0.874
× 11.5	0.697	32.5	8.14	3.11	9.63	1.31	0.775	0.623	0.572	1.57	0.211	0.130	16.5	3.41	0.862

(Continued)

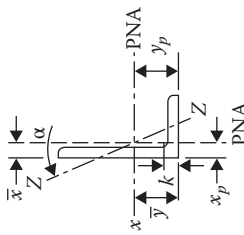
**TABLE C.2b (Continued)**  
**C Shapes Properties**

Shape	Shear Center, $e_0$ (in.)	Axis x-x				Axis y-y				Torsional Properties					
		$I$ (in. <sup>4</sup> )	$S$ (in. <sup>3</sup> )	$r$ (in.)	$Z$ (in. <sup>3</sup> )	$I$ (in. <sup>4</sup> )	$S$ (in. <sup>3</sup> )	$r$ (in.)	$\bar{x}$ (in.)	$Z$ (in. <sup>3</sup> )	$x_p$ (in.)	$J$ (in. <sup>4</sup> )	$C_w$ (in. <sup>6</sup> )	$\bar{r}_0$ (in.)	$H$
C7 × 14.7	0.441	27.2	7.78	2.51	9.75	1.37	0.772	0.561	0.532	1.63	0.309	0.267	13.1	2.75	0.875
× 12.2	0.538	24.2	6.92	2.59	8.46	1.16	0.696	0.568	0.525	1.42	0.257	0.161	11.2	2.86	0.862
× 9.8	0.647	21.2	6.07	2.72	7.19	0.957	0.617	0.578	0.541	1.26	0.205	0.0996	9.15	3.02	0.846
C6 × 13	0.380	17.3	5.78	2.13	7.29	1.05	0.638	0.524	0.514	1.35	0.318	0.237	7.19	2.37	0.858
× 10.5	0.486	15.1	5.04	2.22	6.18	0.860	0.561	0.529	0.500	1.14	0.256	0.128	5.91	2.48	0.842
× 8.2	0.599	13.1	4.35	2.34	5.16	0.687	0.488	0.536	0.512	0.987	0.199	0.0736	4.70	2.65	0.823
C5 × 9	0.427	8.89	3.56	1.84	4.39	0.624	0.444	0.486	0.478	0.913	0.264	0.109	2.93	2.10	0.815
× 6.7	0.552	7.48	2.99	1.95	3.55	0.470	0.372	0.489	0.484	0.757	0.215	0.0549	2.22	2.26	0.790
C4 × 7.2	0.386	4.58	2.29	1.47	2.84	0.425	0.337	0.447	0.459	0.695	0.266	0.0817	1.24	1.75	0.767
C4 × 6.25	0.434	4.00	2.00	1.50	2.43	0.345	0.284	0.441	0.435	0.569	0.221	0.0487	1.03	1.79	0.764
× 5.4	0.501	3.85	1.92	1.56	2.29	0.312	0.277	0.444	0.457	0.565	0.231	0.0399	0.921	1.88	0.742
× 4.5	0.587	3.65	1.83	1.63	2.12	0.289	0.265	0.457	0.493	0.531	0.321	0.0322	0.871	2.01	0.710
C3 × 6	0.322	2.07	1.38	1.09	1.74	0.300	0.263	0.413	0.455	0.543	0.294	0.0725	0.462	1.40	0.690
× 5	0.392	1.85	1.23	1.12	1.52	0.241	0.228	0.405	0.439	0.464	0.245	0.0425	0.379	1.45	0.673
× 4.1	0.461	1.65	1.10	1.17	1.32	0.191	0.196	0.398	0.437	0.399	0.262	0.0269	0.307	1.53	0.655
× 3.5	0.493	1.57	1.04	1.20	1.24	0.169	0.182	0.394	0.443	0.364	0.296	0.0226	0.276	1.57	0.646

Source: Courtesy of the American Institute of Steel Construction, Chicago, Illinois.



**TABLE C.3a**  
Angles Properties



Shape	k (in.)	Wt. (lb./ft.)	Area, A (in. <sup>2</sup> )	J (in. <sup>4</sup> )	S (in. <sup>3</sup> )	Axis x-x			Flexural-Torsional Properties			
						r (in.)	$\bar{y}$ (in.)	Z (in. <sup>3</sup> )	$y_p$ (in.)	J (in. <sup>4</sup> )	$C_w$ (in. <sup>4</sup> )	$\bar{r}_0$ (in.)
L4 × 3½ × 1/2	7/8	11.9	3.50	5.30	1.92	1.23	1.24	3.46	0.500	0.301	0.302	2.03
× 3/8	3/4	9.10	2.68	4.15	1.48	1.25	1.20	2.66	0.427	0.132	0.134	2.06
× 5/16	1/16	7.70	2.25	3.53	1.25	1.25	1.17	2.24	0.400	0.0782	0.0798	2.08
× 1/4	5/8	6.20	1.82	2.89	1.01	1.26	1.14	1.81	0.360	0.0412	0.0419	2.09
L4 × 3 × 5/8	1	13.6	3.99	6.01	2.28	1.23	1.37	4.08	0.808	0.529	0.472	1.91
× 1/2	7/8	11.1	3.25	5.02	1.87	1.24	1.32	3.36	0.750	0.281	0.255	1.94
× 3/8	3/4	8.50	2.49	3.94	1.44	1.26	1.27	2.60	0.680	0.123	0.114	1.97
× 5/16	1/16	7.20	2.09	3.36	1.22	1.27	1.25	2.19	0.656	0.0731	0.0676	1.98
× 1/4	5/8	5.80	1.69	2.75	0.988	1.27	1.22	1.77	0.620	0.0386	0.0356	1.99
L3½ × 3½ × 1/2	7/8	11.1	3.25	3.63	1.48	1.05	1.05	2.66	0.464	0.281	0.238	1.87
× 7/16	1/16	9.80	2.89	3.25	1.32	1.06	1.03	2.36	0.413	0.192	0.164	1.89
× 3/8	3/4	8.50	2.50	2.86	1.15	1.07	1.00	2.06	0.357	0.123	0.106	1.90
× 5/16	1/16	7.20	2.10	2.44	0.969	1.08	0.979	1.74	0.300	0.0731	0.0634	1.92
× 1/4	5/8	5.80	1.70	2.00	0.787	1.09	0.954	1.41	0.243	0.0386	0.0334	1.93
L3½ × 3 × 1/2	7/8	10.2	3.02	3.45	1.45	1.07	1.12	2.61	0.480	0.260	0.191	1.75
× 7/16	1/16	9.10	2.67	3.10	1.29	1.08	1.09	2.32	0.449	0.178	0.132	1.76
× 3/8	3/4	7.90	2.32	2.73	1.12	1.09	1.07	2.03	0.407	0.114	0.0858	1.78
× 5/16	1/16	6.60	1.95	2.33	0.951	1.09	1.05	1.72	0.380	0.0680	0.0512	1.79
× 1/4	5/8	5.40	1.58	1.92	0.773	1.10	1.02	1.39	0.340	0.0360	0.0270	1.80

(Continued)

**TABLE C.3a (Continued)**  
**Angles Properties**

Shape	k (in.)	Wt. (lb./ft.)	Area, A (in. <sup>2</sup> )	J (in. <sup>4</sup> )	S (in. <sup>3</sup> )	Axis x-x				Flexural-Torsional Properties			
						r (in.)	$\bar{y}$ (in.)	Z (in. <sup>3</sup> )	$y_p$ (in. <sup>4</sup> )	J (in. <sup>4</sup> )	$C_w$ (in. <sup>4</sup> )	$\bar{r}_0$ (in.)	
L3½ × 2½ × 1/2 × 3/8 × 5/16 × 1/4	7/8	9.40	2.77	3.24	1.41	1.08	1.20	2.52	0.730	0.234	0.159	1.66	
	3/4	7.20	2.12	2.56	1.09	1.10	1.15	1.96	0.673	0.103	0.0714	1.69	
	1½	6.10	1.79	2.20	0.925	1.11	1.13	1.67	0.636	0.0611	0.0426	1.71	
	5/8	4.90	1.45	1.81	0.753	1.12	1.10	1.36	0.600	0.0322	0.0225	1.72	
L3 × 3 × 1/2 × 7/16 × 3/8 × 5/16 × 1/4	7/8	9.40	2.76	2.20	1.06	0.895	0.929	1.91	0.460	0.230	0.144	1.59	
	1¾	8.30	2.43	1.98	0.946	0.903	0.907	1.70	0.405	0.157	0.100	1.60	
	3/4	7.20	2.11	1.75	0.825	0.910	0.884	1.48	0.352	0.101	0.0652	1.62	
	1½	6.10	1.78	1.50	0.699	0.918	0.860	1.26	0.297	0.0597	0.0390	1.64	
L3 × 2½ × 1/2 × 7/16 × 3/8 × 5/16 × 1/4	5/8	4.90	1.44	1.23	0.569	0.926	0.836	1.02	0.240	0.0313	0.0206	1.65	
	9/16	3.71	1.09	0.948	0.433	0.933	0.812	0.774	0.182	0.0136	0.00899	1.67	
	7/8	8.50	2.50	2.07	1.03	0.910	0.995	1.86	0.500	0.213	0.112	1.46	
	1¾	7.60	2.22	1.87	0.921	0.917	0.972	1.66	0.463	0.146	0.0777	1.48	
L3 × 2 × 1/2 × 3/8 × 5/16 × 1/4 × 3/16	3/4	6.60	1.93	1.65	0.803	0.924	0.949	1.45	0.427	0.0943	0.0507	1.49	
	1½	5.60	1.63	1.41	0.681	0.932	0.925	1.23	0.392	0.0560	0.0304	1.51	
	5/8	4.50	1.32	1.16	0.555	0.940	0.900	1.000	0.360	0.0296	0.0161	1.52	
	9/16	3.39	1.00	0.899	0.423	0.947	0.874	0.761	0.333	0.0130	0.00705	1.54	
L2½ × 2 × 1/2 × 3/8 × 5/16 × 1/4 × 3/16	1¾	7.70	2.26	1.92	1.00	0.922	1.08	1.78	0.740	0.192	0.0908	1.39	
	1½	5.90	1.75	1.54	0.779	0.937	1.03	1.39	0.667	0.0855	0.0413	1.42	
	5/8	5.00	1.48	1.32	0.662	0.945	1.01	1.19	0.632	0.0510	0.0248	1.43	
	9/16	4.10	1.20	1.09	0.541	0.953	0.980	0.969	0.600	0.0270	0.0132	1.45	
L2½ × 2½ × 1/2 × 3/8 × 5/16 × 1/4 × 3/16	1/2	3.07	0.917	0.847	0.414	0.961	0.952	0.743	0.555	0.0119	0.00576	1.46	
	3/4	7.70	2.26	1.22	0.716	0.735	0.803	1.29	0.452	0.188	0.0791	1.30	
	5/8	5.90	1.73	0.972	0.558	0.749	0.758	1.01	0.346	0.0833	0.0362	1.33	
	9/16	5.00	1.46	0.837	0.474	0.756	0.735	0.853	0.292	0.0495	0.0218	1.35	
L2 × 2 × 1/2 × 3/16	1/2	4.10	1.19	0.692	0.387	0.764	0.711	0.695	0.238	0.0261	0.0116	1.36	
	7/16	3.07	0.901	0.535	0.295	0.771	0.687	0.529	0.180	0.0114	0.00510	1.38	

$L2\frac{1}{2} \times 2 \times 3/8$	5/8	5.30	1.55	0.914	0.546	0.766	0.826	0.982	0.433	0.0746	0.0268	1.22
× 5/16	9/16	4.50	1.32	0.790	0.465	0.774	0.803	0.839	0.388	0.0444	0.0162	1.23
× 1/4	1/2	3.62	1.07	0.656	0.381	0.782	0.779	0.688	0.360	0.0235	0.00868	1.25
× 3/16	7/16	2.75	0.818	0.511	0.293	0.790	0.754	0.529	0.319	0.0103	0.00382	1.26
$L2\frac{1}{2} \times 1\frac{1}{2} \times 1/4$	1/2	3.19	0.947	0.594	0.364	0.792	0.866	0.644	0.606	0.0209	0.00694	1.19
× 3/16	7/16	2.44	0.724	0.464	0.280	0.801	0.839	0.497	0.569	0.00921	0.00306	1.20
$L2 \times 2 \times 3/8$	5/8	4.70	1.37	0.476	0.348	0.591	0.632	0.629	0.343	0.0658	0.0174	1.05
× 5/16	9/16	3.92	1.16	0.414	0.298	0.598	0.609	0.537	0.290	0.0393	0.0106	1.06
× 1/4	1/2	3.19	0.944	0.346	0.244	0.605	0.586	0.440	0.236	0.0209	0.00572	1.08
× 3/16	7/16	2.44	0.722	0.271	0.188	0.612	0.561	0.338	0.181	0.00921	0.00254	1.09
× 1/8	3/8	1.65	0.491	0.189	0.129	0.620	0.534	0.230	0.123	0.00293	0.000789	1.10

Source: Courtesy of the American Institute of Steel Construction, Chicago, Illinois.

Note: For compactness criteria, refer to the end of Table C.3b.

Workable Gages in Angles Legs (in.)

Leg	8	7	6	5	4	3 <sup>1/2</sup>	3	2 <sup>1/2</sup>	2	1 <sup>3/4</sup>	1 <sup>1/2</sup>	1 <sup>1/4</sup>	1	5/8
g	4 <sup>1/2</sup>	4	3 <sup>1/2</sup>	3	2 <sup>1/2</sup>	2	1 <sup>3/4</sup>	1 <sup>3/8</sup>	1 <sup>1/8</sup>	1	7/8	3/4	5/8	
g <sub>1</sub>	3	2 <sup>1/2</sup>	2 <sup>1/4</sup>	2										
g <sub>2</sub>	3	3	2 <sup>1/2</sup>	1 <sup>3/4</sup>										

Note: Other gages are permitted to suit specific requirements subject to clearances and edge distance limitations.

**TABLE C.3b**  
Angles Other Properties

Shape	Axis y-y				Axis z-z				$Q_s$ $F_y = 36 \text{ ksi}$		
	$I$ (in. <sup>4</sup> )	$S$ (in. <sup>3</sup> )	$r$ (in.)	$\bar{x}$ (in.)	$Z$ (in. <sup>3</sup> )	$x_p$ (in.)	$I$ (in. <sup>4</sup> )	$S$ (in. <sup>3</sup> )		$r$ (in.)	$\tan \alpha$
L4 × 3½ × 1/2 × 3/8 × 5/16 × 1/4	3.76 2.96 2.52 2.07	1.50 1.16 0.980 0.794	1.04 1.05 1.06 1.07	0.994 0.947 0.923 0.897	2.69 2.06 1.74 1.40	0.438 0.335 0.281 0.228	1.80 1.38 1.17 0.950	1.17 0.938 0.811 0.653	0.716 0.719 0.721 0.723	0.750 0.755 0.757 0.759	1.00 1.00 0.997 0.912
L4 × 3 × 5/8 × 1/2 × 3/8 × 5/16 × 1/4	2.85 2.40 1.89 1.62 1.33	1.34 1.10 0.851 0.721 0.585	0.845 0.858 0.873 0.880 0.887	0.867 0.822 0.775 0.750 0.725	2.45 1.99 1.52 1.28 1.03	0.499 0.406 0.311 0.261 0.211	1.59 1.30 1.01 0.851 0.691	1.13 0.927 0.705 0.591 0.476	0.631 0.633 0.636 0.638 0.639	0.534 0.542 0.551 0.554 0.558	1.00 1.00 1.00 0.997 0.912
L3½ × 3½ × 1/2 × 7/16 × 3/8 × 5/16 × 1/4	3.63 3.25 2.86 2.44 2.00	1.48 1.32 1.15 0.969 0.787	1.05 1.06 1.07 1.08 1.09	1.05 1.03 1.00 0.979 0.954	2.66 2.36 2.06 1.74 1.41	0.464 0.413 0.357 0.300 0.243	1.51 1.34 1.17 0.989 0.807	1.01 0.920 0.821 0.714 0.598	0.679 0.681 0.683 0.685 0.688	1.00 1.00 1.00 1.00 1.00	1.00 1.00 1.00 0.965 1.00
L3½ × 3 × 1/2 × 7/16 × 3/8 × 5/16 × 1/4	2.32 2.09 1.84 1.58 1.30	1.09 0.971 0.847 0.718 0.585	0.877 0.885 0.892 0.900 0.908	0.869 0.846 0.823 0.798 0.773	1.97 1.75 1.52 1.28 1.04	0.431 0.381 0.331 0.279 0.226	1.15 1.03 0.895 0.761 0.623	0.851 0.774 0.692 0.602 0.487	0.618 0.620 0.622 0.624 0.628	0.713 0.717 0.720 0.722 0.725	1.00 1.00 1.00 1.00 0.965
L3½ × 2½ × 1/2 × 3/8 × 5/16 × 1/4	1.36 1.09 0.937 0.775	0.756 0.589 0.501 0.410	0.701 0.716 0.723 0.731	0.701 0.655 0.632 0.607	1.39 1.07 0.900 0.728	0.396 0.303 0.256 0.207	0.782 0.608 0.518 0.425	0.649 0.496 0.419 0.340	0.532 0.535 0.538 0.541	0.485 0.495 0.500 0.504	1.00 1.00 1.00 0.965
L3 × 3 × 1/2 × 7/16 × 3/8	2.20 1.98 1.75	1.06 0.946 0.825	0.895 0.903 0.910	0.929 0.907 0.884	1.91 1.70 1.48	0.460 0.405 0.352	0.924 0.819 0.712	0.703 0.639 0.570	0.580 0.580 0.581	1.00 1.00 1.00	1.00 1.00 1.00

× 5/16	1.50	0.699	0.918	0.860	1.26	0.297	0.603	0.496	0.583	1.00	1.00
× 1/4	1.23	0.569	0.926	0.836	1.02	0.240	0.491	0.415	0.585	1.00	1.00
× 3/16	0.948	0.433	0.933	0.812	0.774	0.182	0.374	0.326	0.586	1.00	0.912
L3 × 2½ × 1/2	1.29	0.736	0.718	0.746	1.34	0.417	0.666	0.568	0.516	0.666	1.00
× 7/16	1.17	0.656	0.724	0.724	1.19	0.370	0.591	0.517	0.516	0.671	1.00
× 3/8	1.03	0.573	0.731	0.701	1.03	0.322	0.514	0.463	0.517	0.675	1.00
× 5/16	0.888	0.487	0.739	0.677	0.873	0.272	0.437	0.404	0.518	0.679	1.00
× 1/4	0.734	0.397	0.746	0.653	0.707	0.220	0.356	0.327	0.520	0.683	1.00
× 3/16	0.568	0.303	0.753	0.627	0.536	0.167	0.272	0.247	0.521	0.687	0.912
L3 × 2 × 1/2	0.667	0.470	0.543	0.580	0.887	0.377	0.409	0.411	0.425	0.413	1.00
× 3/8	0.539	0.368	0.555	0.535	0.679	0.292	0.318	0.313	0.426	0.426	1.00
× 5/16	0.467	0.314	0.562	0.511	0.572	0.247	0.271	0.264	0.428	0.432	1.00
× 1/4	0.390	0.258	0.569	0.487	0.463	0.200	0.223	0.214	0.431	0.437	1.00
× 3/16	0.305	0.198	0.577	0.462	0.351	0.153	0.173	0.163	0.435	0.442	0.912
L2½ × 2½ × 1/2	1.22	0.716	0.735	0.803	1.29	0.452	0.521	0.459	0.481	1.00	1.00
× 3/8	0.972	0.558	0.749	0.758	1.01	0.346	0.400	0.373	0.481	1.00	1.00
× 5/16	0.837	0.474	0.756	0.735	0.853	0.292	0.339	0.326	0.481	1.00	1.00
× 1/4	0.692	0.387	0.764	0.711	0.695	0.238	0.275	0.274	0.482	1.00	1.00
× 3/16	0.535	0.295	0.771	0.687	0.529	0.180	0.210	0.216	0.482	1.00	0.983
L2½ × 2 × 3/8	0.513	0.361	0.574	0.578	0.657	0.310	0.273	0.295	0.419	0.612	1.00
× 5/16	0.446	0.309	0.581	0.555	0.557	0.264	0.233	0.260	0.420	0.618	1.00
× 1/4	0.372	0.253	0.589	0.532	0.454	0.214	0.191	0.213	0.423	0.624	1.00
× 3/16	0.292	0.195	0.597	0.508	0.347	0.164	0.149	0.163	0.426	0.628	0.983
L2½ × 1½ × 1/4	0.160	0.142	0.411	0.372	0.261	0.189	0.0975	0.119	0.321	0.354	1.00
× 3/16	0.126	0.110	0.418	0.347	0.198	0.145	0.0760	0.091	0.324	0.360	0.983
L2 × 2 × 3/8	0.476	0.348	0.591	0.632	0.629	0.343	0.203	0.227	0.386	1.00	1.00
× 5/16	0.414	0.298	0.598	0.609	0.537	0.290	0.173	0.20	0.386	1.00	1.00
× 1/4	0.346	0.244	0.605	0.586	0.440	0.236	0.141	0.171	0.387	1.00	1.00
× 3/16	0.271	0.188	0.612	0.561	0.338	0.181	0.109	0.137	0.389	1.00	1.00
× 1/8	0.189	0.129	0.620	0.534	0.230	0.123	0.0751	0.0994	0.391	1.00	0.912

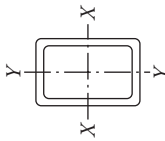
Source: Courtesy of the American Institute of Steel Constructors, Chicago, Illinois.  
 Note: For compactness criteria, refer to the end of this table.

**TABLE C.3c**  
**Compactness Criteria for Angles**

$t$	Compression	Flexure	
	Nonslender up to	Compact up to	Noncompact up to
	Width of Angle Leg (in.)		
1 1/8	8	8	—
1	↓	↓	—
7/8			—
3/4			—
5/8	↓		—
9/16	7	↓	8
1/2	6	7	↓
7/16	5	6	
3/8	4	5	↓
5/16	4	4	
1/4	3	3 1/2	6
3/16	2	2 1/2	4
1/8	1 1/2	1 1/2	3

*Note:* Compactness criteria given for  $F_y = 36$  ksi and  $C_v = 1.0$  for all angles.

**TABLE C.4a**  
**Rectangular HSS Dimensions and Properties**



Shape	Design Wall Thickness, $t$ (in.)	Nominal Wt. (lb./ft.)	Area, $A$ (in. <sup>2</sup> )	Axis $x-x$					
				$b/t$	$h/t$	$I$ (in. <sup>4</sup> )	$S$ (in. <sup>3</sup> )	$r$ (in.)	$Z$ (in. <sup>3</sup> )
HSS6 × 4 × 1/2	0.465	28.43	7.88	5.60	9.90	34.0	11.3	2.08	14.6
	0.349	22.37	6.18	8.46	14.2	28.3	9.43	2.14	11.9
	0.291	19.08	5.26	10.7	17.6	24.8	8.27	2.17	10.3
	0.233	15.62	4.30	14.2	22.8	20.9	6.96	2.20	8.53
HSS6 × 3 × 1/2	0.174	11.97	3.28	20.0	31.5	16.4	5.46	2.23	6.60
	0.116	8.16	2.23	31.5	48.7	11.4	3.81	2.26	4.56
	0.465	25.03	6.95	3.45	9.90	26.8	8.95	1.97	12.1
	0.349	19.82	5.48	5.60	14.2	22.7	7.57	2.04	9.90
HSS6 × 2 × 3/8	0.291	16.96	4.68	7.31	17.6	20.1	6.69	2.07	8.61
	0.233	13.91	3.84	9.88	22.8	17.0	5.66	2.10	7.19
	0.174	10.70	2.93	14.2	31.5	13.4	4.47	2.14	5.59
	0.116	7.31	2.00	22.9	48.7	9.43	3.14	2.17	3.87
HSS6 × 2 × 1/4	0.349	17.27	4.78	2.73	14.2	17.1	5.71	1.89	7.93
	0.291	14.83	4.10	3.87	17.6	15.3	5.11	1.93	6.95
	0.233	12.21	3.37	5.58	22.8	13.1	4.37	1.97	5.84
	0.174	9.42	2.58	8.49	31.5	10.5	3.49	2.01	4.58
HSS6 × 2 × 1/8	0.116	6.46	1.77	14.2	48.7	7.42	2.47	2.05	3.19

(Continued)

**TABLE C.4a (Continued)**  
 Rectangular HSS Dimensions and Properties

Shape	Design Wall Thickness, $t$ (in.)	Nominal Wt. (lb./ft.)	Area, $A$ (in. <sup>2</sup> )	Axis x-x					
				$b/t$	$h/t$	$I$ (in. <sup>4</sup> )	$S$ (in. <sup>3</sup> )	$r$ (in.)	$Z$ (in. <sup>3</sup> )
HSS5 × 4 × 1/2	0.465	25.03	6.95	5.60	7.75	21.2	8.49	1.75	10.9
	0.349	19.82	5.48	8.46	11.3	17.9	7.17	1.81	8.96
	0.291	16.96	4.68	10.7	14.2	15.8	6.32	1.84	7.79
	0.233	13.91	3.84	14.2	18.5	13.4	5.35	1.87	6.49
HSS5 × 3 × 1/2	0.174	10.70	2.93	20.0	25.7	10.6	4.22	1.90	5.05
	0.116	7.31	2.00	31.5	40.1	7.42	2.97	1.93	3.50
	0.465	21.63	6.02	3.45	7.75	16.4	6.57	1.65	8.83
	0.349	17.27	4.78	5.60	11.3	14.1	5.65	1.72	7.34
HSS5 × 2 1/2 × 1/4	0.291	14.83	4.10	7.31	14.2	12.6	5.03	1.75	6.42
	0.233	12.21	3.37	9.88	18.5	10.7	4.29	1.78	5.38
	0.174	9.42	2.58	14.2	25.7	8.53	3.41	1.82	4.21
	0.116	6.46	1.77	22.9	40.1	6.03	2.41	1.85	2.93
HSS5 × 2 × 3/8	0.233	11.36	3.14	7.73	18.5	9.40	3.76	1.73	4.83
	0.174	8.78	2.41	11.4	25.7	7.51	3.01	1.77	3.79
	0.116	6.03	1.65	18.6	40.1	5.34	2.14	1.80	2.65
	0.349	14.72	4.09	2.73	11.3	10.4	4.14	1.59	5.71
HSS5 × 2 × 1/4	0.291	12.70	3.52	3.87	14.2	9.35	3.74	1.63	5.05
	0.233	10.51	2.91	5.58	18.5	8.08	3.23	1.67	4.27
	0.174	8.15	2.24	8.49	25.7	6.50	2.60	1.70	3.37
	0.116	5.61	1.54	14.2	40.1	4.65	1.86	1.74	2.37



HSS4 × 3 × 3/8	0.349	14.72	4.09	5.60	8.46	7.93	3.97	1.39	5.12
	0.291	12.70	3.52	7.31	10.7	7.14	3.57	1.42	4.51
	0.233	10.51	2.91	9.88	14.2	6.15	3.07	1.45	3.81
	0.174	8.15	2.24	14.2	20.0	4.93	2.47	1.49	3.00
HSS4 × 2½ × 3/8	0.116	5.61	1.54	22.9	31.5	3.52	1.76	1.52	2.11
	0.349	13.44	3.74	4.16	8.46	6.77	3.38	1.35	4.48
	0.291	11.64	3.23	5.59	10.7	6.13	3.07	1.38	3.97
	0.233	9.66	2.67	7.73	14.2	5.32	2.66	1.41	3.38
HSS4 × 2 × 3/8	0.174	7.51	2.06	11.4	20.0	4.30	2.15	1.44	2.67
	0.116	5.18	1.42	18.6	31.5	3.09	1.54	1.47	1.88
	0.349	12.17	3.39	2.73	8.46	5.60	2.80	1.29	3.84
	0.291	10.58	2.94	3.87	10.7	5.13	2.56	1.32	3.43
HSS3½ × 2½ × 3/8	0.233	8.81	2.44	5.58	14.2	4.49	2.25	1.36	2.94
	0.174	6.87	1.89	8.49	20.0	3.66	1.83	1.39	2.34
	0.116	4.75	1.30	14.2	31.5	2.65	1.32	1.43	1.66
	0.349	12.17	3.39	4.16	7.03	4.75	2.72	1.18	3.59
HSS3½ × 2 × 1/4	0.291	10.58	2.94	5.59	9.03	4.34	2.48	1.22	3.20
	0.233	8.81	2.44	7.73	12.0	3.79	2.17	1.25	2.74
	0.174	6.87	1.89	11.4	17.1	3.09	1.76	1.28	2.18
	0.116	4.75	1.30	18.6	27.2	2.23	1.28	1.31	1.54
HSS3½ × 2 × 1/8	0.233	7.96	2.21	5.58	12.0	3.17	1.81	1.20	2.36
	0.174	6.23	1.71	8.49	17.1	2.61	1.49	1.23	1.89
HSS3½ × 2 × 1/8	0.116	4.33	1.19	14.2	27.2	1.90	1.09	1.27	1.34

Source: Courtesy of the American Institute of Steel Construction, Chicago, Illinois.

**TABLE C.4b**  
**Rectangular HSS Other Properties**



Shape	Axis y-y			Workable Flat		Torsion		Surface Area (ft. <sup>2</sup> /ft.)	
	<i>I</i> (in. <sup>4</sup> )	<i>S</i> (in. <sup>3</sup> )	<i>r</i> (in.)	<i>Z</i> (in. <sup>3</sup> )	Depth (in.)	Width (in.)	<i>J</i> (in. <sup>4</sup> )		<i>C</i> (in. <sup>3</sup> )
HSS6 × 4 × 1/2 × 3/8 × 5/16 × 1/4 × 3/16	17.8	8.89	1.50	11.0	3 <sup>3</sup> / <sub>4</sub>	— <sup>a</sup>	40.3	17.8	1.53
	14.9	7.47	1.55	8.94	4 <sup>5</sup> / <sub>16</sub>	2 <sup>5</sup> / <sub>16</sub>	32.8	14.2	1.57
	13.2	6.58	1.58	7.75	4 <sup>5</sup> / <sub>8</sub>	2 <sup>5</sup> / <sub>8</sub>	28.4	12.2	1.58
	11.1	5.56	1.61	6.45	4 <sup>7</sup> / <sub>8</sub>	2 <sup>7</sup> / <sub>8</sub>	23.6	10.1	1.60
	8.76	4.38	1.63	5.00	5 <sup>3</sup> / <sub>16</sub>	3 <sup>3</sup> / <sub>16</sub>	18.2	7.74	1.62
HSS6 × 3 × 1/2 × 3/8 × 5/16 × 1/4 × 3/16	6.15	3.08	1.66	3.46	5 <sup>7</sup> / <sub>16</sub>	3 <sup>7</sup> / <sub>16</sub>	12.6	5.30	1.63
	8.69	5.79	1.12	7.28	3 <sup>3</sup> / <sub>4</sub>	— <sup>a</sup>	23.1	12.7	1.37
	7.48	4.99	1.17	6.03	4 <sup>5</sup> / <sub>16</sub>	— <sup>a</sup>	19.3	10.3	1.40
	6.67	4.45	1.19	5.27	4 <sup>5</sup> / <sub>8</sub>	— <sup>a</sup>	16.9	8.91	1.42
	5.70	3.80	1.22	4.41	4 <sup>7</sup> / <sub>8</sub>	— <sup>a</sup>	14.2	7.39	1.43
HSS6 × 2 × 3/8 × 1/8 × 5/16 × 1/4 × 3/16	4.55	3.03	1.25	3.45	5 <sup>3</sup> / <sub>16</sub>	2 <sup>3</sup> / <sub>16</sub>	11.1	5.71	1.45
	3.23	2.15	1.27	2.40	5 <sup>7</sup> / <sub>16</sub>	2 <sup>7</sup> / <sub>16</sub>	7.73	3.93	1.47
	2.77	2.77	0.760	3.46	4 <sup>5</sup> / <sub>16</sub>	— <sup>a</sup>	8.42	6.35	1.23
	2.52	2.52	0.785	3.07	4 <sup>5</sup> / <sub>8</sub>	— <sup>a</sup>	7.60	5.58	1.25
	2.21	2.21	0.810	2.61	4 <sup>7</sup> / <sub>8</sub>	— <sup>a</sup>	6.55	4.70	1.27
HSS5 × 4 × 1/2 × 3/8 × 5/16 × 1/4 × 3/16	1.80	1.80	0.836	2.07	5 <sup>7</sup> / <sub>16</sub>	— <sup>a</sup>	5.24	3.68	1.28
	1.31	1.31	0.861	1.46	5 <sup>7</sup> / <sub>16</sub>	— <sup>a</sup>	3.72	2.57	1.30
	14.9	7.43	1.46	9.35	2 <sup>3</sup> / <sub>4</sub>	— <sup>a</sup>	30.3	14.5	1.37
	12.6	6.30	1.52	7.67	3 <sup>3</sup> / <sub>16</sub>	2 <sup>5</sup> / <sub>16</sub>	24.9	11.7	1.40
	11.1	5.57	1.54	6.67	3 <sup>5</sup> / <sub>8</sub>	2 <sup>5</sup> / <sub>8</sub>	21.7	10.1	1.42
HSS5 × 4 × 1/2 × 1/4 × 3/16	9.46	4.73	1.57	5.57	3 <sup>3</sup> / <sub>8</sub>	2 <sup>3</sup> / <sub>8</sub>	18.0	8.32	1.43
	7.48	3.74	1.60	4.34	4 <sup>3</sup> / <sub>16</sub>	3 <sup>3</sup> / <sub>16</sub>	14.0	6.41	1.45
	5.27	2.64	1.62	3.01	4 <sup>7</sup> / <sub>16</sub>	3 <sup>7</sup> / <sub>16</sub>	9.66	4.39	1.47

HSS5 × 3 × 1/2	7.18	4.78	1.09	6.10	2 <sup>3</sup> / <sub>4</sub>	— <sup>a</sup>	17.6	10.3	1.20
× 3/8	6.25	4.16	1.14	5.10	3 <sup>5</sup> / <sub>16</sub>	— <sup>a</sup>	14.9	8.44	1.23
× 5/16	5.60	3.73	1.17	4.48	3 <sup>3</sup> / <sub>8</sub>	— <sup>a</sup>	13.1	7.33	1.25
× 1/4	4.81	3.21	1.19	3.77	3 <sup>7</sup> / <sub>8</sub>	— <sup>a</sup>	11.0	6.10	1.27
× 3/16	3.85	2.57	1.22	2.96	4 <sup>3</sup> / <sub>16</sub>	2 <sup>3</sup> / <sub>16</sub>	8.64	4.73	1.28
× 1/8	2.75	1.83	1.25	2.07	4 <sup>7</sup> / <sub>16</sub>	2 <sup>7</sup> / <sub>16</sub>	6.02	3.26	1.30
HSS5 × 2 <sup>1</sup> / <sub>2</sub> × 1/4	3.13	2.50	0.999	2.95	3 <sup>7</sup> / <sub>8</sub>	— <sup>a</sup>	7.93	4.99	1.18
× 3/16	2.53	2.03	1.02	2.33	4 <sup>3</sup> / <sub>16</sub>	— <sup>a</sup>	6.26	3.89	1.20
× 1/8	1.82	1.46	1.05	1.64	4 <sup>7</sup> / <sub>16</sub>	— <sup>a</sup>	4.40	2.70	1.22
HSS5 × 2 × 3/8	2.28	2.28	0.748	2.88	3 <sup>5</sup> / <sub>16</sub>	— <sup>a</sup>	6.61	5.20	1.07
× 5/16	2.10	2.10	0.772	2.57	3 <sup>3</sup> / <sub>8</sub>	— <sup>a</sup>	5.99	4.59	1.08
× 1/4	1.84	1.84	0.797	2.20	3 <sup>7</sup> / <sub>8</sub>	— <sup>a</sup>	5.17	3.88	1.10
× 3/16	1.51	1.51	0.823	1.75	4 <sup>3</sup> / <sub>16</sub>	— <sup>a</sup>	4.15	3.05	1.12
× 1/8	1.10	1.10	0.848	1.24	4 <sup>7</sup> / <sub>16</sub>	— <sup>a</sup>	2.95	2.13	1.13
HSS4 × 3 × 3/8	5.01	3.34	1.11	4.18	2 <sup>5</sup> / <sub>16</sub>	— <sup>a</sup>	10.6	6.59	1.07
× 5/16	4.52	3.02	1.13	3.69	2 <sup>3</sup> / <sub>8</sub>	— <sup>a</sup>	9.41	5.75	1.08
× 1/4	3.91	2.61	1.16	3.12	2 <sup>7</sup> / <sub>8</sub>	— <sup>a</sup>	7.96	4.81	1.10
× 3/16	3.16	2.10	1.19	2.46	3 <sup>3</sup> / <sub>16</sub>	— <sup>a</sup>	6.26	3.74	1.12
× 1/8	2.27	1.51	1.21	1.73	3 <sup>7</sup> / <sub>16</sub>	— <sup>a</sup>	4.38	2.59	1.13
HSS4 × 2 <sup>1</sup> / <sub>2</sub> × 3/8	3.17	2.54	0.922	3.20	2 <sup>5</sup> / <sub>16</sub>	— <sup>a</sup>	7.57	5.32	0.983
× 5/16	2.89	2.32	0.947	2.85	2 <sup>3</sup> / <sub>8</sub>	— <sup>a</sup>	6.77	4.67	1.00
× 1/4	2.53	2.02	0.973	2.43	2 <sup>7</sup> / <sub>8</sub>	— <sup>a</sup>	5.78	3.93	1.02
× 3/16	2.06	1.65	0.999	1.93	3 <sup>3</sup> / <sub>8</sub>	— <sup>a</sup>	4.59	3.08	1.03
× 1/8	1.49	1.19	1.03	1.36	3 <sup>7</sup> / <sub>16</sub>	— <sup>a</sup>	3.23	2.14	1.05
HSS4 × 2 × 3/8	1.80	1.80	0.729	2.31	2 <sup>5</sup> / <sub>16</sub>	— <sup>a</sup>	4.83	4.04	0.900
× 5/16	1.67	1.67	0.754	2.08	2 <sup>3</sup> / <sub>8</sub>	— <sup>a</sup>	4.40	3.59	0.917
× 1/4	1.48	1.48	0.779	1.79	2 <sup>7</sup> / <sub>8</sub>	— <sup>a</sup>	3.82	3.05	0.933
× 3/16	1.22	1.22	0.804	1.43	3 <sup>3</sup> / <sub>16</sub>	— <sup>a</sup>	3.08	2.41	0.950
× 1/8	0.898	0.898	0.830	1.02	3 <sup>7</sup> / <sub>16</sub>	— <sup>a</sup>	2.20	1.69	0.967

(Continued)

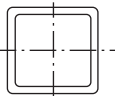
**TABLE C.4b (Continued)**  
**Rectangular HSS Other Properties**

Shape	Axis y-y				Workable Flat		Torsion		Surface Area (ft. <sup>2</sup> /ft.)
	<i>I</i> (in. <sup>4</sup> )	<i>S</i> (in. <sup>3</sup> )	<i>r</i> (in.)	<i>Z</i> (in. <sup>3</sup> )	Depth (in.)	Width (in.)	<i>J</i> (in. <sup>4</sup> )	<i>C</i> (in. <sup>3</sup> )	
HSS3 1/2 × 2 1/2 × 3/8 × 5/16 × 1/4 × 3/16 × 1/8	2.77	2.21	0.904	2.82	— <sup>a</sup>	— <sup>a</sup>	6.16	4.57	0.900
	2.54	2.03	0.930	2.52	2 1/8	— <sup>a</sup>	5.53	4.03	0.917
	2.23	1.78	0.956	2.16	2 3/8	— <sup>a</sup>	4.75	3.40	0.933
	1.82	1.46	0.983	1.72	2 11/16	— <sup>a</sup>	3.78	2.67	0.950
HSS3 1/2 × 2 × 1/4 × 3/16 × 1/8	1.33	1.06	1.01	1.22	2 15/16	— <sup>a</sup>	2.67	1.87	0.967
	1.30	1.30	0.766	1.58	2 3/8	— <sup>a</sup>	3.16	2.64	0.850
	1.08	1.08	0.792	1.27	2 11/16	— <sup>a</sup>	2.55	2.09	0.867
	0.795	0.795	0.818	0.912	2 15/16	— <sup>a</sup>	1.83	1.47	0.883

Source: Courtesy of the American Institute of Steel Construction, Chicago, Illinois.

<sup>a</sup> Flat depth or width is too small to establish a workable flat.

**TABLE C.5**  
**Square HSS: Dimensions and Properties**



**HSS7-HSS4 1/2**

Shape	Design Wall Thickness, <i>t</i> (in.)	Nominal Wt. (lb/ft.)	Area, <i>A</i> (in. <sup>2</sup> )	<i>b/t</i>	<i>h/t</i>	<i>I</i> (in. <sup>4</sup> )	<i>S</i> (in. <sup>3</sup> )	<i>r</i> (in.)	<i>Z</i> (in. <sup>3</sup> )	Workable Flat (in.)	Torsion		Surface Area (ft. <sup>2</sup> /ft.)
											<i>J</i> (in. <sup>4</sup> )	<i>C</i> (in. <sup>3</sup> )	
HSS7 × 7 × 5/8	0.581	50.81	14.0	9.05	9.05	93.4	26.7	2.58	33.1	4 <sup>3/16</sup>	158	47.1	2.17
	0.465	42.05	11.6	12.1	12.1	80.5	23.0	2.63	27.9	4 <sup>1/4</sup>	133	39.3	2.20
	0.349	32.58	8.97	17.1	17.1	65.0	18.6	2.69	22.1	5 <sup>1/16</sup>	105	30.7	2.23
	0.291	27.59	7.59	21.1	21.1	56.1	16.0	2.72	18.9	5 <sup>1/8</sup>	89.7	26.1	2.25
	0.233	22.42	6.17	27.0	27.0	46.5	13.3	2.75	15.5	5 <sup>1/4</sup>	73.5	21.3	2.27
	0.174	17.08	4.67	37.2	37.2	36.0	10.3	2.77	11.9	6 <sup>3/16</sup>	56.1	16.2	2.28
HSS6 × 6 × 5/8	0.116	11.56	3.16	57.3	57.3	24.8	7.09	2.80	8.13	6 <sup>1/16</sup>	38.2	11.0	2.30
	0.581	42.30	11.7	7.33	7.33	55.2	18.4	2.17	23.2	3 <sup>3/16</sup>	94.9	33.4	1.83
	0.465	35.24	9.74	9.90	9.90	48.3	16.1	2.23	19.8	3 <sup>1/4</sup>	81.1	28.1	1.87
	0.349	27.48	7.58	14.2	14.2	39.5	13.2	2.28	15.8	4 <sup>5/16</sup>	64.6	22.1	1.90
	0.291	23.34	6.43	17.6	17.6	34.3	11.4	2.31	13.6	4 <sup>1/2</sup>	55.4	18.9	1.92
	0.233	19.02	5.24	22.8	22.8	28.6	9.54	2.34	11.2	4 <sup>3/4</sup>	45.6	15.4	1.93
HSS5 1/2 × 5 1/2 × 3/8	0.174	14.53	3.98	31.5	31.5	22.3	7.42	2.37	8.63	5 <sup>3/16</sup>	35.0	11.8	1.95
	0.116	9.86	2.70	48.7	48.7	15.5	5.15	2.39	5.92	5 <sup>1/8</sup>	23.9	8.03	1.97
	0.349	24.93	6.88	12.8	12.8	29.7	10.8	2.08	13.1	3 <sup>13/16</sup>	49.0	18.4	1.73
	0.291	21.21	5.85	15.9	15.9	25.9	9.43	2.11	11.3	4 <sup>1/8</sup>	42.2	15.7	1.75
	0.233	17.32	4.77	20.6	20.6	21.7	7.90	2.13	9.32	4 <sup>1/4</sup>	34.8	12.9	1.77
	0.174	13.25	3.63	28.6	28.6	17.0	6.17	2.16	7.19	4 <sup>11/16</sup>	26.7	9.85	1.78
× 1/8	0.116	9.01	2.46	44.4	44.4	11.8	4.30	2.19	4.95	4 <sup>15/16</sup>	18.3	6.72	1.80

(continued)

**TABLE C.5 (Continued)**  
**Square HSS: Dimensions and Properties**

Shape	Design Wall Thickness, <i>t</i> (in.)	Nominal Wt. (lb./ft.)	Area, <i>A</i> (in. <sup>2</sup> )	<i>b/t</i>	<i>h/t</i>	<i>I</i> (in. <sup>4</sup> )	<i>S</i> (in. <sup>3</sup> )	<i>r</i> (in.)	<i>Z</i> (in. <sup>3</sup> )	Workable Flat (in.)	Torsion		Surface Area (ft. <sup>2</sup> /ft.)
											<i>J</i> (in. <sup>4</sup> )	<i>C</i> (in. <sup>3</sup> )	
HSS5 × 5 × 1/2 × 3/8 × 5/16 × 1/4 × 3/16 × 1/8	0.465	28.43	7.88	7.75	7.75	26.0	10.4	1.82	13.1	2 <sup>3</sup> / <sub>4</sub>	44.6	18.7	1.53
	0.349	22.37	6.18	11.3	11.3	21.7	8.68	1.87	10.6	3 <sup>5</sup> / <sub>16</sub>	36.1	14.9	1.57
	0.291	19.08	5.26	14.2	14.2	19.0	7.62	1.90	9.16	3 <sup>5</sup> / <sub>8</sub>	31.2	12.8	1.58
	0.233	15.62	4.30	18.5	18.5	16.0	6.41	1.93	7.61	3 <sup>3</sup> / <sub>8</sub>	25.8	10.5	1.60
	0.174	11.97	3.28	25.7	25.7	12.6	5.03	1.96	5.89	4 <sup>3</sup> / <sub>16</sub>	19.9	8.08	1.62
HSS4½ × 4½ × 1/2 × 3/8 × 5/16 × 1/4 × 3/16 × 1/8	0.116	8.16	2.23	40.1	40.1	8.80	3.52	1.99	4.07	4 <sup>3</sup> / <sub>16</sub>	13.7	5.53	1.63
	0.465	25.03	6.95	6.68	6.68	18.1	8.03	1.61	10.2	2 <sup>1</sup> / <sub>4</sub>	31.3	14.8	1.37
	0.349	19.82	5.48	9.89	9.89	15.3	6.79	1.67	8.36	2 <sup>3</sup> / <sub>16</sub>	25.7	11.9	1.40
	0.291	16.96	4.68	12.5	12.5	13.5	6.00	1.70	7.27	3 <sup>1</sup> / <sub>8</sub>	22.3	10.2	1.42
	0.233	13.91	3.84	16.3	16.3	11.4	5.08	1.73	6.06	3 <sup>3</sup> / <sub>8</sub>	18.5	8.44	1.43
HSS4 × 4 × 1/2 × 3/8 × 5/16 × 1/4 × 3/16 × 1/8	0.174	10.70	2.93	22.9	22.9	9.02	4.01	1.75	4.71	3 <sup>1</sup> / <sub>16</sub>	14.4	6.49	1.45
	0.116	7.31	2.00	35.8	35.8	6.35	2.82	1.78	3.27	3 <sup>5</sup> / <sub>16</sub>	9.92	4.45	1.47
	0.465	21.63	6.02	5.60	5.60	11.9	5.97	1.41	7.70	— <sup>a</sup>	21.0	11.2	1.20
	0.349	17.27	4.78	8.46	8.46	10.3	5.13	1.47	6.39	2 <sup>3</sup> / <sub>16</sub>	17.5	9.14	1.23
	0.291	14.83	4.10	10.7	10.7	9.14	4.57	1.49	5.59	2 <sup>5</sup> / <sub>8</sub>	15.3	7.91	1.25
HSS3½ × 3½ × 3/8 × 5/16 × 1/4 × 3/16 × 1/8	0.233	12.21	3.37	14.2	14.2	7.80	3.90	1.52	4.69	2 <sup>5</sup> / <sub>8</sub>	12.8	6.56	1.27
	0.174	9.42	2.58	20.0	20.0	6.21	3.10	1.55	3.67	3 <sup>3</sup> / <sub>16</sub>	10.0	5.07	1.28
	0.116	6.46	1.77	31.5	31.5	4.40	2.20	1.58	2.56	3 <sup>3</sup> / <sub>16</sub>	6.91	3.49	1.30
	0.349	14.72	4.09	7.03	7.03	6.49	3.71	1.26	4.69	— <sup>a</sup>	11.2	6.77	1.07
	0.291	12.70	3.52	9.03	9.03	5.84	3.34	1.29	4.14	2 <sup>1</sup> / <sub>4</sub>	9.89	5.90	1.08
HSS3 × 3 × 3/8 × 5/16 × 1/4 × 3/16 × 1/8	0.233	10.51	2.91	12.0	12.0	5.04	2.88	1.32	3.50	2 <sup>5</sup> / <sub>8</sub>	8.35	4.92	1.10
	0.174	8.15	2.24	17.1	17.1	4.05	2.31	1.35	2.76	2 <sup>1</sup> / <sub>16</sub>	6.56	3.83	1.12
	0.116	5.61	1.54	27.2	27.2	2.90	1.66	1.37	1.93	2 <sup>5</sup> / <sub>16</sub>	4.58	2.65	1.13
	0.349	12.17	3.39	5.60	5.60	3.78	2.52	1.06	3.25	— <sup>a</sup>	6.64	4.74	0.900
	0.291	10.58	2.94	7.31	7.31	3.45	2.30	1.08	2.90	— <sup>a</sup>	5.94	4.18	0.917
0.233	8.81	2.44	9.88	9.88	3.02	2.01	1.11	2.48	— <sup>a</sup>	5.08	3.52	0.933	

× 3/16	0.174	6.87	1.89	14.2	14.2	2.46	1.64	1.14	1.97	2 3/16	4.03	2.76	0.950
× 1/8	0.116	4.75	1.30	22.9	22.9	1.78	1.19	1.17	1.40	2 3/16	2.84	1.92	0.967
HSS2 1/2 × 2 1/2 × 5/16	0.291	8.45	2.35	5.59	5.59	1.82	1.46	0.880	1.88	— <sup>a</sup>	3.20	2.74	0.750
× 1/4	0.233	7.11	1.97	7.73	7.73	1.63	1.30	0.908	1.63	— <sup>a</sup>	2.79	2.35	0.767
× 3/16	0.174	5.59	1.54	11.4	11.4	1.35	1.08	0.937	1.32	— <sup>a</sup>	2.25	1.86	0.784
× 1/8	0.116	3.90	1.07	18.6	18.6	0.998	0.799	0.965	0.947	— <sup>a</sup>	1.61	1.31	0.800
HSS2 1/4 × 2 1/4 × 1/4	0.233	6.26	1.74	6.66	6.66	1.13	1.01	0.806	1.28	— <sup>a</sup>	1.96	1.85	0.683
× 3/16	0.174	4.96	1.37	9.93	9.93	0.953	0.847	0.835	1.04	— <sup>a</sup>	1.60	1.48	0.700
× 1/8	0.116	3.48	0.956	16.4	16.4	0.712	0.633	0.863	0.755	— <sup>a</sup>	1.15	1.05	0.717
HSS2 × 2 × 1/4	0.233	5.41	1.51	5.58	5.58	0.747	0.747	0.704	0.964	— <sup>a</sup>	1.31	1.41	0.600
× 3/16	0.174	4.32	1.19	8.49	8.49	0.641	0.641	0.733	0.797	— <sup>a</sup>	1.09	1.14	0.617
× 1/8	0.116	3.05	0.840	14.2	14.2	0.486	0.486	0.761	0.584	— <sup>a</sup>	0.796	0.817	0.633

Source: Courtesy of the American Institute of Steel Construction, Chicago, Illinois.

<sup>a</sup> Flat depth or width is too small to establish a workable flat.

**TABLE C.6**  
**Round HSS: Dimensions and Properties**



Shape	Design Wall Thickness, $t$ (in.)	Nominal Wt. (lb./ft.)	Area, $A$ (in. <sup>2</sup> )	$D/t$	$I$ (in. <sup>4</sup> )	$S$ (in. <sup>3</sup> )	$r$ (in.)	$Z$ (in. <sup>3</sup> )	Torsion	
									$J$ (in. <sup>4</sup> )	$C$ (in. <sup>3</sup> )
HSS6.625 × 0.500	0.465	32.74	9.00	14.2	42.9	13.0	2.18	17.7	85.9	25.9
× 0.432	0.402	28.60	7.86	16.5	38.2	11.5	2.20	15.6	76.4	23.1
× 0.375	0.349	25.06	6.88	19.0	34.0	10.3	2.22	13.8	68.0	20.5
× 0.312	0.291	21.06	5.79	22.8	29.1	8.79	2.24	11.7	58.2	17.6
× 0.280	0.260	18.99	5.20	25.5	26.4	7.96	2.25	10.5	52.7	15.9
× 0.250	0.233	17.04	4.68	28.4	23.9	7.22	2.26	9.52	47.9	14.4
× 0.188	0.174	12.94	3.53	38.1	18.4	5.54	2.28	7.24	36.7	11.1
× 0.125 <sup>a</sup>	0.116	8.69	2.37	57.1	12.6	3.79	2.30	4.92	25.1	7.59
HSS6.000 × 0.500	0.465	29.40	8.09	12.9	31.2	10.4	1.96	14.3	62.4	20.8
× 0.375	0.349	22.55	6.20	17.2	24.8	8.28	2.00	11.2	49.7	16.6
× 0.312	0.291	18.97	5.22	20.6	21.3	7.11	2.02	9.49	42.6	14.2
× 0.280	0.260	17.12	4.69	23.1	19.3	6.45	2.03	8.57	38.7	12.9
× 0.250	0.233	15.37	4.22	25.8	17.6	5.86	2.04	7.75	35.2	11.7
× 0.188	0.174	11.68	3.18	34.5	13.5	4.51	2.06	5.91	27.0	9.02
× 0.125 <sup>a</sup>	0.116	7.85	2.14	51.7	9.28	3.09	2.08	4.02	18.6	6.19
HSS5.563 × 0.500	0.465	27.06	7.45	12.0	24.4	8.77	1.81	12.1	48.8	17.5
× 0.375	0.349	20.80	5.72	15.9	19.5	7.02	1.85	9.50	39.0	14.0
× 0.258	0.240	14.63	4.01	23.2	14.2	5.12	1.88	6.80	28.5	10.2
× 0.188	0.174	10.80	2.95	32.0	10.7	3.85	1.91	5.05	21.4	7.70
× 0.134	0.124	7.78	2.12	44.9	7.84	2.82	1.92	3.67	15.7	5.64



HSS5.500 × 0.500	0.465	26.73	7.36	11.8	23.5	8.55	1.79	11.8	47.0	17.1
× 0.375	0.349	20.55	5.65	15.8	18.8	6.84	1.83	9.27	37.6	13.7
× 0.258	0.240	14.46	3.97	22.9	13.7	5.00	1.86	6.64	27.5	10.0
HSS5.000 × 0.500	0.465	24.05	6.62	10.8	17.2	6.88	1.61	9.60	34.4	13.8
× 0.375	0.349	18.54	5.10	14.3	13.9	5.55	1.65	7.56	27.7	11.1
× 0.312	0.291	15.64	4.30	17.2	12.0	4.79	1.67	6.46	24.0	9.58
× 0.258	0.240	13.08	3.59	20.8	10.2	4.08	1.69	5.44	20.4	8.15
× 0.250	0.233	12.69	3.49	21.5	9.94	3.97	1.69	5.30	19.9	7.95
× 0.188	0.174	9.67	2.64	28.7	7.69	3.08	1.71	4.05	15.4	6.15
× 0.125	0.116	6.51	1.78	43.1	5.31	2.12	1.73	2.77	10.6	4.25
HSS4.500 × 0.375	0.349	16.54	4.55	12.9	9.87	4.39	1.47	6.03	19.7	8.78
× 0.337	0.313	15.00	4.12	14.4	9.07	4.03	1.48	5.50	18.1	8.06
× 0.237	0.220	10.80	2.96	20.5	6.79	3.02	1.52	4.03	13.6	6.04
× 0.188	0.174	8.67	2.36	25.9	5.54	2.46	1.53	3.26	11.1	4.93
× 0.125	0.116	5.85	1.60	38.8	3.84	1.71	1.55	2.23	7.68	3.41
HSS4.000 × 0.313	0.291	12.34	3.39	13.7	5.87	2.93	1.32	4.01	11.7	5.87
× 0.250	0.233	10.00	2.76	17.2	4.91	2.45	1.33	3.31	9.82	4.91
× 0.237	0.220	9.53	2.61	18.2	4.68	2.34	1.34	3.15	9.36	4.68
× 0.226	0.210	9.12	2.50	19.0	4.50	2.25	1.34	3.02	9.01	4.50
× 0.220	0.205	8.89	2.44	19.5	4.41	2.21	1.34	2.96	8.83	4.41
× 0.188	0.174	7.66	2.09	23.0	3.83	1.92	1.35	2.55	7.67	3.83
× 0.125	0.116	5.18	1.42	34.5	2.67	1.34	1.37	1.75	5.34	2.67
HSS3.500 × 0.313	0.291	10.66	2.93	12.0	3.81	2.18	1.14	3.00	7.61	4.35
× 0.300	0.279	10.26	2.82	12.5	3.69	2.11	1.14	2.90	7.38	4.22
× 0.250	0.233	8.69	2.39	15.0	3.21	1.83	1.16	2.49	6.41	3.66
× 0.216	0.201	7.58	2.08	17.4	2.84	1.63	1.17	2.19	5.69	3.25
× 0.203	0.189	7.15	1.97	18.5	2.70	1.54	1.17	2.07	5.41	3.09
× 0.188	0.174	6.66	1.82	20.1	2.52	1.44	1.18	1.93	5.04	2.88
× 0.125	0.116	4.51	1.23	30.2	1.77	1.01	1.20	1.33	3.53	2.02

(Continued)

**TABLE C.6 (Continued)**  
**Round HSS: Dimensions and Properties**

Shape	Design Wall Thickness, $t$ (in.)	Nominal Wt. (lb./ft.)	Area, $A$ (in. <sup>2</sup> )	$D/t$	$I$ (in. <sup>4</sup> )	$S$ (in. <sup>3</sup> )	$r$ (in.)	$Z$ (in. <sup>3</sup> )	Torsion	
									$J$ (in. <sup>4</sup> )	$C$ (in. <sup>3</sup> )
HSS3.000 × 0.250	0.233	7.35	2.03	12.9	1.95	1.30	0.982	1.79	3.90	2.60
	0.201	6.43	1.77	14.9	1.74	1.16	0.992	1.58	3.48	2.32
	0.189	6.07	1.67	15.9	1.66	1.10	0.996	1.50	3.31	2.21
	0.174	5.65	1.54	17.2	1.55	1.03	1.00	1.39	3.10	2.06
	0.141	4.63	1.27	21.3	1.30	0.865	1.01	1.15	2.59	1.73
HSS2.875 × 0.250	0.124	4.11	1.12	24.2	1.16	0.774	1.02	1.03	2.32	1.55
	0.116	3.84	1.05	25.9	1.09	0.730	1.02	0.965	2.19	1.46
	0.233	7.02	1.93	12.3	1.70	1.18	0.938	1.63	3.40	2.37
	0.189	5.80	1.59	15.2	1.45	1.01	0.952	1.37	2.89	2.01
	0.174	5.40	1.48	16.5	1.35	0.941	0.957	1.27	2.70	1.88
HSS2.500 × 0.250	0.116	3.67	1.01	24.8	0.958	0.667	0.976	0.884	1.92	1.33
	0.233	6.01	1.66	10.7	1.08	0.862	0.806	1.20	2.15	1.72
	0.174	4.65	1.27	14.4	0.865	0.692	0.825	0.943	1.73	1.38
	0.116	3.17	0.869	21.6	0.619	0.495	0.844	0.660	1.24	0.990

Source: Courtesy of the American Institute of Steel Construction, Chicago, Illinois.

<sup>a</sup> Shape exceeds compact limit for flexure with  $F_y = 42$  ksi.

**TABLE C.7**  
**Pipe: Dimensions and Properties**



**Pipe**

Shape	Nominal Wt. (lb/ft.)	Dimensions			Nominal Wall Thickness (in.)	Design Wall Thickness (in.)	Area (in. <sup>2</sup> )	D/t	I (in. <sup>4</sup> )	S (in. <sup>3</sup> )	r (in.)	J (in. <sup>4</sup> )	Z (in. <sup>3</sup> )
		Outside Diameter (in.)	Inside Diameter (in.)	Thickness (in.)									
Pipe 12 Std.	49.6	12.8	12.0	0.375	0.349	13.7	36.5	262	41.0	4.39	523	53.7	
Pipe 10 Std.	40.5	10.8	10.0	0.365	0.340	11.5	31.6	151	28.1	3.68	302	36.9	
Pipe 8 Std.	28.6	8.63	7.98	0.322	0.300	7.85	28.8	68.1	15.8	2.95	136	20.8	
Pipe 6 Std.	19.0	6.63	6.07	0.280	0.261	5.20	25.4	26.5	7.99	2.25	52.9	10.6	
Pipe 5 Std.	14.6	5.56	5.05	0.258	0.241	4.01	23.1	14.3	5.14	1.88	28.6	6.83	
Pipe 4 Std.	10.8	4.50	4.03	0.237	0.221	2.96	20.4	6.82	3.03	1.51	13.6	4.05	
Pipe 3½ Std.	9.12	4.00	3.55	0.226	0.211	2.50	19.0	4.52	2.26	1.34	9.04	3.03	
Pipe 3 Std.	7.58	3.50	3.07	0.216	0.201	2.07	17.4	2.85	1.63	1.17	5.69	2.19	
Pipe 2½ Std.	5.80	2.88	2.47	0.203	0.189	1.61	15.2	1.45	1.01	0.952	2.89	1.37	
Pipe 2 Std.	3.66	2.38	2.07	0.154	0.143	1.02	16.6	0.627	0.528	0.791	1.25	0.713	
Pipe 1½ Std.	2.72	1.90	1.61	0.145	0.135	0.749	14.1	0.293	0.309	0.626	0.586	0.421	
Pipe 1¼ Std.	2.27	1.66	1.38	0.140	0.130	0.625	12.8	0.184	0.222	0.543	0.368	0.305	
Pipe 1 Std.	1.68	1.32	1.05	0.133	0.124	0.469	10.6	0.0830	0.126	0.423	0.166	0.177	
Pipe ¾ Std.	1.13	1.05	0.824	0.113	0.105	0.312	10.0	0.0350	0.0671	0.336	0.0700	0.0942	
Pipe ½ Std.	0.850	0.840	0.622	0.109	0.101	0.234	8.32	0.0160	0.0388	0.264	0.0320	0.0555	
<b>Standard Weight (Std.)</b>													
<b>Extra Strong (x-strong)</b>													
Pipe 12 x-strong	65.5	12.8	11.8	0.500	0.465	17.5	27.4	339	53.2	4.35	678	70.2	
Pipe 10 x-strong	54.8	10.8	9.75	0.500	0.465	15.1	23.1	199	37.0	3.64	398	49.2	
Pipe 8 x-strong	43.4	8.63	7.63	0.500	0.465	11.9	18.5	100	23.1	2.89	199	31.0	
Pipe 6 x-strong	28.6	6.63	5.76	0.432	0.403	7.83	16.4	38.3	11.6	2.20	76.6	15.6	

(Continued)

**TABLE C.7 (Continued)**  
**Pipe: Dimensions and Properties**

Shape	Dimensions					Area (in. <sup>2</sup> )	D/t	I (in. <sup>4</sup> )	S (in. <sup>3</sup> )	r (in.)	J (in. <sup>4</sup> )	Z (in. <sup>3</sup> )
	Nominal Wt. (lb./ft.)	Outside Diameter (in.)	Inside Diameter (in.)	Nominal Wall Thickness (in.)	Design Wall Thickness (in.)							
Pipe 5 x-strong	20.8	5.56	4.81	0.375	0.349	5.73	15.9	19.5	7.02	1.85	39.0	9.50
Pipe 4 x-strong	15.0	4.50	3.83	0.337	0.315	4.14	14.3	9.12	4.05	1.48	18.2	5.53
Pipe 3½ x-strong	12.5	4.00	3.36	0.318	0.296	3.43	13.5	5.94	2.97	1.31	11.9	4.07
Pipe 3 x-strong	10.3	3.50	2.90	0.300	0.280	2.83	12.5	3.70	2.11	1.14	7.40	2.91
Pipe 2½ x-strong	7.67	2.88	2.32	0.276	0.257	2.10	11.2	1.83	1.27	0.930	3.66	1.77
Pipe 2 x-strong	5.03	2.38	1.94	0.218	0.204	1.40	11.6	0.827	0.696	0.771	1.65	0.964
Pipe 1½ x-strong	3.63	1.90	1.50	0.200	0.186	1.00	10.2	0.372	0.392	0.610	0.744	0.549
Pipe 1¼ x-strong	3.00	1.66	1.28	0.191	0.178	0.837	9.33	0.231	0.278	0.528	0.462	0.393
Pipe 1 x-strong	2.17	1.32	0.957	0.179	0.166	0.602	7.92	0.101	0.154	0.410	0.202	0.221
Pipe ¾ x-strong	1.48	1.05	0.742	0.154	0.143	0.407	7.34	0.0430	0.0818	0.325	0.0860	0.119
Pipe ½ x-strong	1.09	0.840	0.546	0.147	0.137	0.303	6.13	0.0190	0.0462	0.253	0.0380	0.0686
<b>Double-Extra Strong (xx-strong)</b>												
Pipe 8 xx-strong	72.5	8.63	6.88	0.875	0.816	20.0	10.6	154	35.8	2.78	308	49.9
Pipe 6 xx-strong	53.2	6.63	4.90	0.864	0.805	14.7	8.23	63.5	19.2	2.08	127	27.4
Pipe 5 xx-strong	38.6	5.56	4.06	0.750	0.699	10.7	7.96	32.2	11.6	1.74	64.4	16.7
Pipe 4 xx-strong	27.6	4.50	3.15	0.674	0.628	7.66	7.17	14.7	6.53	1.39	29.4	9.50
Pipe 3 xx-strong	18.6	3.50	2.30	0.600	0.559	5.17	6.26	5.79	3.31	1.06	11.6	4.89
Pipe 2½ xx-strong	13.7	2.88	1.77	0.552	0.514	3.83	5.59	2.78	1.94	0.854	5.56	2.91
Pipe 2 xx-strong	9.04	2.38	1.50	0.436	0.406	2.51	5.85	1.27	1.07	0.711	2.54	1.60

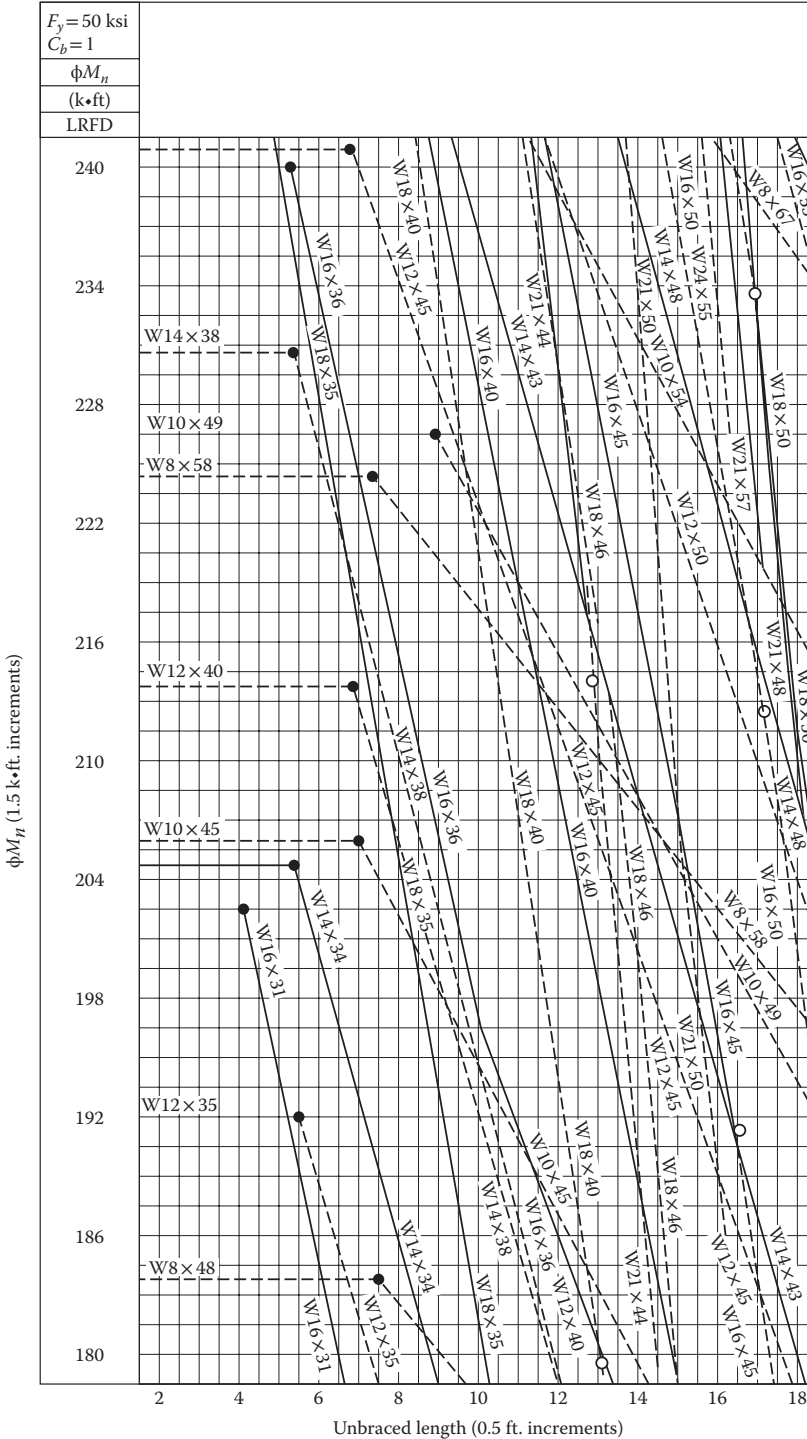
Source: Courtesy of the American Institute of Steel Construction, Chicago, Illinois.

**TABLE C.8**  
**Available Strength in Axial Compression, Kips: W Shapes,  $F_y = 50$  ksi**

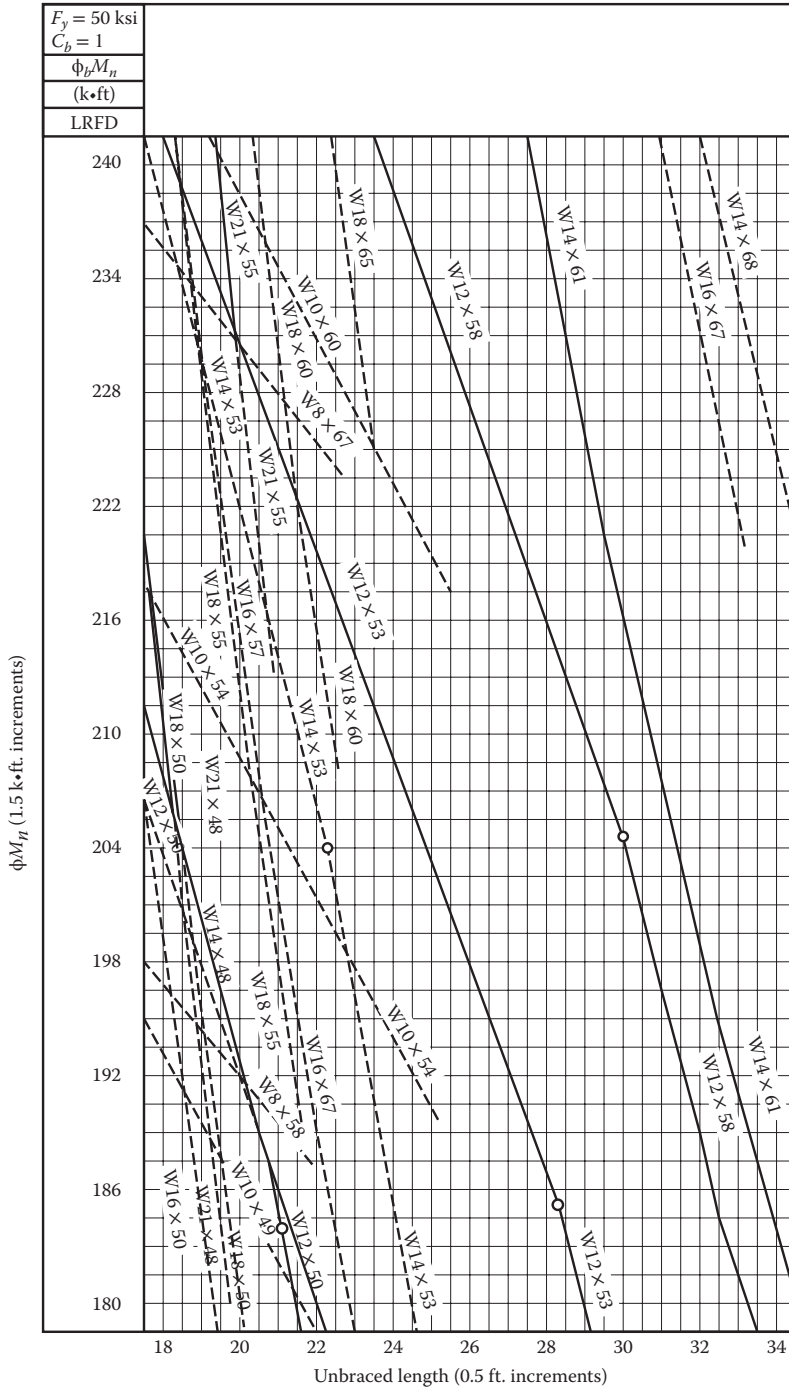
Shape	W14x				W12x				W10x							
	82	74	68	61	53	48	58	53	50	45	40	54	49	45	39	33
Weight per Foot	$\phi_c P_n$	$\phi_c P_n$	$\phi_c P_n$	$\phi_c P_n$	$\phi_c P_n$	$\phi_c P_n$	$\phi_c P_n$	$\phi_c P_n$	$\phi_c P_n$	$\phi_c P_n$	$\phi_c P_n$	$\phi_c P_n$	$\phi_c P_n$	$\phi_c P_n$	$\phi_c P_n$	$\phi_c P_n$
Design	LRFD	LRFD	LRFD	LRFD	LRFD	LRFD	LRFD	LRFD	LRFD	LRFD	LRFD	LRFD	LRFD	LRFD	LRFD	LRFD
	0	1080	981	900	805	702	634	765	702	657	589	526	711	648	598	517
6	1020	922	845	756	633	572	720	660	595	534	476	671	611	545	470	395
7	993	902	826	739	610	551	705	646	574	515	459	651	598	527	454	381
8	968	879	805	720	585	527	687	629	551	494	440	624	584	507	436	365
9	940	854	782	699	557	502	668	611	526	471	420	605	568	485	416	348
10	910	827	756	676	528	475	647	592	500	447	398	605	550	461	396	330
11	878	797	729	651	497	447	625	571	472	422	375	585	532	437	374	311
12	844	767	701	626	465	419	601	549	443	396	352	564	512	411	352	292
13	809	735	671	599	433	390	577	526	413	369	328	542	492	385	329	272
14	772	701	640	571	401	360	551	502	384	343	304	519	471	359	306	253
15	735	667	608	543	369	331	525	478	355	316	281	495	449	333	283	233
16	697	633	577	514	338	303	499	453	326	290	257	471	427	307	260	214
17	659	598	544	485	308	276	472	428	298	265	235	447	404	282	238	195
18	620	563	512	456	278	249	445	403	270	240	213	422	382	257	217	177
19	582	529	480	428	250	224	418	378	244	216	191	398	360	234	196	159
20	545	495	449	399	226	202	392	354	220	195	173	374	337	211	177	143
22	472	428	388	345	186	167	341	307	182	161	143	327	294	174	146	118
24	402	365	330	293	157	140	292	261	153	136	120	282	253	146	123	99.5
26	343	311	281	249	133	119	249	223	130	116	102	240	216	125	105	84.8
28	295	268	242	215	115	103	214	192	112	100	88	207	186	108	90	73.1
30	257	234	211	187	100	90	187	167	98	87	77	180	162	94	79	63.7
32	226	205	185	165	88.1		164	147	86	76	67	159	142	82	69	56.0
34	200	182	164	146			145	130				141	126			
36	179	162	147	130			130	116				112	101			
38	160	146	131	117			116	104				112	101			
40	145	131	119	105			105	94				102	91			

Source: Courtesy of the American Institute of Steel Construction, Chicago, Illinois.  
 Note: LRFD, load resistance factor design.

**TABLE C.9**  
**W Shapes: Available Moment versus Unbraced Length**  
**Load Resistance Factor Design**



**TABLE C.9 (Continued)**  
**W Shapes: Available Moment versus Unbraced Length**  
**Load Resistance Factor Design**



Source: Courtesy of the American Institute of Steel Construction, Chicago, Illinois.

**TABLE C.10a**  
**Standard Load Table for Open-Web Steel Joists, K-Series (8K to 16K)**

Based on 50 ksi Maximum Yield Strength—Loads Shown in Pounds per Linear Foot

Joist Designation	8K1	10K1	12K1	12K3	12K5	14K1	14K3	14K4	14K6	16K2	16K3	16K4	16K5	16K6	16K7	16K9
Depth (in.)	8	10	12	12	12	14	14	14	14	16	16	16	16	16	16	16
Approx. Wt. (lb./ft.)	5.1	5.0	5.0	5.7	7.1	5.2	6.0	6.7	7.7	5.5	6.3	7.0	7.5	8.1	8.6	10.0
Span (ft.)																
↓	825															
8	550															
9	825															
	550															
10	825	825														
	480	550														
11	798	825														
	377	542														
12	666	825	825	825	825											
	288	455	550	550	550											
13	565	718	825	825	825											
	225	363	510	510	510											
14	486	618	750	825	825	825	825	825	825							
	179	289	425	463	463	550	550	550	550							
15	421	537	651	814	825	766	825	825	825	825						
	145	234	344	428	434	475	507	507	507							
16	369	469	570	714	825	672	825	825	825	825	825	825	825	825	825	825
	119	192	282	351	396	390	467	467	467	550	550	550	550	550	550	550
17	415	504	630	630	825	592	742	825	825	768	825	825	825	825	825	825
	159	234	291	291	366	324	404	443	443	488	526	526	526	526	526	526
18	369	448	561	561	760	528	661	795	825	684	762	825	825	825	825	825
	134	197	245	245	317	272	339	397	408	409	456	490	490	490	490	490
19	331	402	502	502	681	472	592	712	825	612	682	820	825	825	825	825



20	113	167	207	269	230	287	336	383	347	386	452	455	455
	<b>298</b>	<b>361</b>	<b>453</b>	<b>613</b>	<b>426</b>	<b>534</b>	<b>642</b>	<b>787</b>	<b>552</b>	<b>615</b>	<b>739</b>	<b>825</b>	<b>825</b>
	97	142	177	230	197	246	267	347	297	330	386	426	426
21		<b>327</b>	<b>409</b>	<b>555</b>	<b>385</b>	<b>483</b>	<b>582</b>	<b>712</b>	<b>499</b>	<b>556</b>	<b>670</b>	<b>822</b>	<b>825</b>
	123	153	198	170	212	248	248	299	255	285	333	405	406
22		<b>298</b>	<b>373</b>	<b>505</b>	<b>351</b>	<b>439</b>	<b>529</b>	<b>648</b>	<b>454</b>	<b>505</b>	<b>609</b>	<b>747</b>	<b>825</b>
	106	132	172	147	184	215	215	259	222	247	289	361	385
23		<b>271</b>	<b>340</b>	<b>462</b>	<b>321</b>	<b>402</b>	<b>483</b>	<b>592</b>	<b>415</b>	<b>462</b>	<b>556</b>	<b>682</b>	<b>825</b>
	93	116	150	128	160	188	188	226	194	216	252	307	363
24		<b>249</b>	<b>312</b>	<b>423</b>	<b>294</b>	<b>367</b>	<b>442</b>	<b>543</b>	<b>381</b>	<b>424</b>	<b>510</b>	<b>627</b>	<b>825</b>
	81	101	132	113	141	165	165	199	170	189	221	248	346
25					<b>270</b>	<b>339</b>	<b>408</b>	<b>501</b>	<b>351</b>	<b>390</b>	<b>469</b>	<b>576</b>	<b>771</b>
	100	124	145	100	124	145	145	175	150	167	195	219	311
26				<b>249</b>	<b>313</b>	<b>376</b>	<b>376</b>	<b>462</b>	<b>324</b>	<b>360</b>	<b>433</b>	<b>489</b>	<b>711</b>
	88	110	129	88	110	129	129	156	133	148	173	194	276
27				<b>231</b>	<b>289</b>	<b>349</b>	<b>349</b>	<b>427</b>	<b>300</b>	<b>334</b>	<b>402</b>	<b>453</b>	<b>658</b>
	79	98	115	79	98	115	115	139	119	132	155	173	246
28				<b>214</b>	<b>270</b>	<b>324</b>	<b>324</b>	<b>397</b>	<b>279</b>	<b>310</b>	<b>373</b>	<b>421</b>	<b>612</b>
	70	88	103	70	88	103	103	124	106	118	138	155	220
29									<b>259</b>	<b>289</b>	<b>348</b>	<b>391</b>	<b>570</b>
									95	106	124	139	198
30									<b>241</b>	<b>270</b>	<b>324</b>	<b>366</b>	<b>532</b>
									86	96	112	126	178
31									<b>226</b>	<b>252</b>	<b>304</b>	<b>342</b>	<b>498</b>
									78	87	101	114	161
32									<b>213</b>	<b>237</b>	<b>285</b>	<b>321</b>	<b>466</b>
									71	79	92	103	147

Source: Courtesy of the Steel Joist Institute, Forest, Virginia.

**TABLE C.10b**

**Standard Load Table for Open-Web Steel Joists, K-Series (18K to 22K)**

Based on 50 ksi Maximum Yield Strength—Loads Shown in Pounds per Linear Foot

Joist Designation	18K3	18K4	18K5	18K6	18K7	18K9	18K10	20K3	20K4	20K5	20K6	20K7	20K9	20K10	22K4	22K5	22K6	22K7	22K9	22K10	22K11
Depth (in.)	18	18	18	18	18	18	18	18	18	18	20	20	20	20	22	22	22	22	22	22	22
Approx. Wt. (lb/ft.)	6.6	7.2	7.7	8.5	9	10.2	11.7	6.7	7.6	8.2	8.9	9.3	10.8	12.2	8	8.8	9.2	9.7	11.3	12.6	13.8
Span (ft.)																					
↓	825	825	825	825	825	825	825	825	825	825	825	825	825	825	825	825	825	825	825	825	825
18	550	550	550	550	550	550	550	550	550	550	550	550	550	550	548	548	548	548	548	548	548
19	771	825	825	825	825	825	825	825	825	825	825	825	825	825	777	825	825	825	825	825	825
	494	523	523	523	523	523	523	523	523	523	523	523	523	520	448	468	468	468	468	468	468
20	694	825	825	825	825	825	825	775	825	825	825	825	825	825	825	825	825	825	825	825	825
	423	490	490	490	490	490	490	517	550	550	550	550	550	550	490	490	490	490	490	490	490
21	630	759	825	825	825	825	825	702	825	825	825	825	825	825	825	825	825	825	825	825	825
	364	426	460	460	460	460	460	463	520	520	520	520	520	520	520	520	520	520	520	520	520
22	573	690	777	825	825	825	825	639	771	825	825	825	825	825	825	825	825	825	825	825	825
	316	370	414	438	438	438	438	393	461	490	490	490	490	490	548	548	548	548	548	548	548
23	523	630	709	774	825	825	825	583	703	793	825	825	825	825	777	825	825	825	825	825	825
	276	323	362	393	418	418	418	344	402	451	468	468	468	468	491	518	518	518	518	518	518
24	480	577	651	709	789	825	825	535	645	727	792	825	825	825	712	804	825	825	825	825	825
	242	284	318	345	382	396	396	302	353	396	430	448	448	448	431	483	495	495	495	495	495
25	441	532	600	652	727	825	825	493	594	669	729	811	825	825	657	739	805	825	825	825	825
	214	250	281	305	337	377	377	266	312	350	380	421	426	426	381	427	464	474	474	474	474
26	408	492	553	603	672	807	825	456	549	618	673	750	825	825	606	682	744	825	825	825	825
	190	222	249	271	299	354	361	236	277	310	337	373	405	405	338	379	411	454	454	454	454
27	378	454	513	558	622	747	825	421	508	573	624	694	825	825	561	633	688	768	825	825	825
	169	198	222	241	267	315	347	211	247	277	301	333	389	389	301	337	367	406	432	432	432
28	351	423	477	519	577	694	822	391	472	532	579	645	775	825	522	588	640	712	825	825	825

29	151	177	199	216	239	282	331	189	221	248	269	298	353	375	270	302	328	364	413	413
	<b>327</b>	<b>394</b>	<b>444</b>	<b>483</b>	<b>538</b>	<b>646</b>	<b>766</b>	<b>364</b>	<b>439</b>	<b>495</b>	<b>540</b>	<b>601</b>	<b>723</b>	<b>825</b>	<b>486</b>	<b>547</b>	<b>597</b>	<b>664</b>	<b>798</b>	<b>825</b>
30	136	159	179	194	215	254	298	170	199	223	242	268	317	359	242	272	295	327	387	399
-	<b>304</b>	<b>367</b>	<b>414</b>	<b>451</b>	<b>502</b>	<b>603</b>	<b>715</b>	<b>340</b>	<b>411</b>	<b>462</b>	<b>504</b>	<b>561</b>	<b>675</b>	<b>799</b>	<b>453</b>	<b>511</b>	<b>556</b>	<b>619</b>	<b>745</b>	<b>825</b>
31	123	144	161	175	194	229	269	153	179	201	218	242	286	336	219	245	266	295	349	385
	<b>285</b>	<b>343</b>	<b>387</b>	<b>421</b>	<b>469</b>	<b>564</b>	<b>669</b>	<b>318</b>	<b>384</b>	<b>433</b>	<b>471</b>	<b>525</b>	<b>631</b>	<b>748</b>	<b>424</b>	<b>478</b>	<b>520</b>	<b>580</b>	<b>697</b>	<b>825</b>
	111	130	146	158	175	207	243	138	162	182	198	219	259	304	198	222	241	267	316	369
32	<b>267</b>	<b>322</b>	<b>363</b>	<b>396</b>	<b>441</b>	<b>529</b>	<b>627</b>	<b>298</b>	<b>360</b>	<b>406</b>	<b>442</b>	<b>492</b>	<b>592</b>	<b>702</b>	<b>397</b>	<b>448</b>	<b>489</b>	<b>544</b>	<b>654</b>	<b>823</b>
	101	118	132	144	159	188	221	126	147	165	179	199	235	276	180	201	219	242	287	337
33	<b>252</b>	<b>303</b>	<b>342</b>	<b>372</b>	<b>414</b>	<b>498</b>	<b>589</b>	<b>280</b>	<b>339</b>	<b>381</b>	<b>415</b>	<b>463</b>	<b>566</b>	<b>660</b>	<b>373</b>	<b>421</b>	<b>459</b>	<b>511</b>	<b>615</b>	<b>729</b>
	92	108	121	131	145	171	201	114	134	150	163	181	214	251	164	183	199	221	261	307
34	<b>237</b>	<b>285</b>	<b>321</b>	<b>349</b>	<b>390</b>	<b>468</b>	<b>555</b>	<b>264</b>	<b>318</b>	<b>358</b>	<b>391</b>	<b>435</b>	<b>523</b>	<b>621</b>	<b>352</b>	<b>397</b>	<b>432</b>	<b>481</b>	<b>579</b>	<b>687</b>
	84	98	110	120	132	156	184	105	122	137	149	165	195	229	149	167	182	202	239	280
35	<b>223</b>	<b>268</b>	<b>303</b>	<b>330</b>	<b>367</b>	<b>441</b>	<b>523</b>	<b>249</b>	<b>300</b>	<b>339</b>	<b>369</b>	<b>411</b>	<b>493</b>	<b>585</b>	<b>331</b>	<b>373</b>	<b>408</b>	<b>454</b>	<b>546</b>	<b>648</b>
	77	90	101	110	121	143	168	96	112	126	137	151	179	210	137	153	167	185	219	257
36	<b>211</b>	<b>253</b>	<b>286</b>	<b>312</b>	<b>348</b>	<b>417</b>	<b>495</b>	<b>235</b>	<b>283</b>	<b>319</b>	<b>348</b>	<b>388</b>	<b>466</b>	<b>553</b>	<b>313</b>	<b>354</b>	<b>385</b>	<b>429</b>	<b>516</b>	<b>612</b>
	70	82	92	101	111	132	154	88	103	115	125	139	164	193	126	141	153	169	201	236
37								<b>222</b>	<b>268</b>	<b>303</b>	<b>330</b>	<b>367</b>	<b>441</b>	<b>523</b>	<b>297</b>	<b>334</b>	<b>364</b>	<b>406</b>	<b>487</b>	<b>579</b>
								81	95	106	115	128	151	178	116	130	141	156	186	217
38								<b>211</b>	<b>255</b>	<b>286</b>	<b>312</b>	<b>348</b>	<b>418</b>	<b>496</b>	<b>280</b>	<b>316</b>	<b>345</b>	<b>384</b>	<b>462</b>	<b>549</b>
								74	87	98	106	118	139	164	107	119	130	144	170	200
39								<b>199</b>	<b>241</b>	<b>271</b>	<b>297</b>	<b>330</b>	<b>397</b>	<b>471</b>	<b>267</b>	<b>300</b>	<b>327</b>	<b>364</b>	<b>438</b>	<b>520</b>
								69	81	90	98	109	129	151	98	110	120	133	157	185
40								<b>190</b>	<b>229</b>	<b>258</b>	<b>282</b>	<b>313</b>	<b>376</b>	<b>447</b>	<b>253</b>	<b>285</b>	<b>310</b>	<b>346</b>	<b>417</b>	<b>495</b>
								64	75	84	91	101	119	140	91	102	111	123	146	171
41															<b>241</b>	<b>271</b>	<b>295</b>	<b>330</b>	<b>396</b>	<b>471</b>
															85	95	103	114	135	159
42															<b>229</b>	<b>259</b>	<b>282</b>	<b>313</b>	<b>378</b>	<b>448</b>
															79	88	96	106	126	148

(Continued)

**TABLE C.10b (Continued)**  
**Load Resistance Factor Design**

Standard Load Table for Open-Web Steel Joists, K-Series  
 Based on 50 ksi Maximum Yield Strength—Loads Shown in Pounds per Linear Foot

Joist Designation	18K3	18K4	18K5	18K6	18K7	18K9	18K10	20K3	20K4	20K5	20K6	20K7	20K9	20K10	22K4	22K5	22K6	22K7	22K9	22K10	22K11
Depth (in.)	18	18	18	18	18	18	18	18	18	18	20	20	20	20	22	22	22	22	22	22	22
Approx. Wt. (lb/ft.)	6.6	7.2	7.7	8.5	9	10.2	11.7	6.7	7.6	8.2	8.9	9.3	10.8	12.2	8	8.8	9.2	9.7	11.3	12.6	13.8
															219	247	268	300	360	427	489
															73	82	89	99	117	138	157
															208	235	256	286	343	408	466
															68	76	83	92	109	128	146

Source: Courtesy of the Steel Joist Institute, Forest, Virginia.

**TABLE C.11**  
**Design Guide LRFD Weight Table for Joist Girders**  
**Based on 50 ksi Yield Strength**

Girder Span (ft.)	Joist Spaces (ft.)	Girder Depth (in.)	Joist Girder Weight—Pounds per Linear Foot Factored Load on Each Panel Point (k)																			
			6.0	9.0	12.0	15.0	18.0	21.0	24.0	27.0	30.0	36.0	42.0	48.0	54.0	60.0	66.0	72.0	78.0	84.0		
20	2N @ 10.00	20	16	19	19	19	19	19	20	24	24	24	25	30	37	41	46	50	56	62	70	75
		24	16	19	19	19	20	21	25	28	32	36	41	42	49	52	53	66				
		28	16	19	19	19	20	20	21	23	26	28	32	39	40	42	46	48	49			
		20	15	15	19	19	20	23	24	27	31	36	44	48	54	74	75	81	84	89		
	3N @ 6.67	24	15	16	16	16	19	20	23	26	27	33	36	45	47	53	56	68	79	82		
		28	15	16	16	16	17	20	24	24	26	31	36	44	46	49	53	57	68	80		
		20	15	15	19	21	25	29	33	38	41	50	57	65	71	88	97	100	107	120		
		24	15	16	17	20	23	26	29	32	35	44	50	55	62	71	85	90	100	102		
	4N @ 5.00	28	16	16	17	19	22	25	28	30	34	39	49	50	59	63	72	86	91	91		
		20	15	17	21	26	31	36	39	48	51	62	71	82	99	109	120	141	142			
		24	16	16	20	23	26	30	35	39	43	53	60	68	80	91	101	103	110	120		
		28	16	16	18	22	27	28	33	37	39	48	55	64	68	77	93	95	107	111		
6N @ 3.33	20	16	19	25	29	36	41	50	57	58	72	82	99	107	118	138	141	147				
	24	16	18	22	28	31	37	43	46	53	61	70	85	102	102	111	123	144	147			
	28	17	18	22	26	30	33	40	42	47	58	68	76	83	96	109	112	119	130			
	20	19	25	32	41	51	58	65	72	82	99	118	139	142	149	153	166					
8N @ 2.50	24	17	22	29	36	42	50	54	61	69	86	103	107	128	149	153	166					
	28	18	22	29	34	40	47	54	61	67	76	88	107	112	124	135	155					
	20	21	21	22	22	22	23	24	24	25	34	39	43	49	55	62	69	76	78			
	24	18	21	21	22	22	22	23	24	24	30	33	41	41	45	51	55	61	73			
3N @ 7.33	28	18	21	21	21	22	22	22	22	23	30	33	33	41	42	46	48	51	58			
	20	15	18	18	19	22	24	26	29	33	42	45	53	68	70	76	84	88	94			
	24	15	15	19	19	20	23	24	26	30	35	40	45	48	55	61	74	81	84			
	28	15	16	16	16	19	20	23	24	27	32	36	45	47	52	54	59	74	82			
4N @ 5.50	20	15	16	19	23	26	30	36	39	44	55	62	71	82	95	96	106	119	134			
	24	15	15	17	20	25	27	29	34	38	48	52	58	71	79	89	98	101	107			
	28	16	16	16	19	22	25	28	32	35	40	49	54	60	72	79	87	90	97			

(Continued)

**TABLE C.11 (Continued)**  
**Design Guide LRFD Weight Table for Joist Girders**  
**Based on 50 ksi Yield Strength**

Girder Span (ft.)	Joist Spaces (ft.)	Girder Depth (in.)	Joist Girder Weight—Pounds per Linear Foot Factored Load on Each Panel Point (k)																		
			6.0	9.0	12.0	15.0	18.0	21.0	24.0	27.0	30.0	36.0	42.0	48.0	54.0	60.0	66.0	72.0	78.0	84.0	
25	5N @ 4.40	20	15	17	24	27	34	38	42	49	55	65	75	96	98	111	126	137			
		24	16	16	20	24	28	33	38	40	48	56	62	73	85	100	101	110	116	133	
		28	16	16	18	22	26	30	32	38	41	51	57	65	73	86	92	102	105	111	
	6N @ 3.67	20	16	21	27	33	39	49	56	57	65	79	97	106	118	137					
		24	16	19	23	28	32	39	45	51	58	66	82	98	101	109	120	142	144		
		28	16	18	22	26	30	34	39	44	50	61	70	76	89	102	104	113	127	148	
	8N @ 2.75	20	19	27	36	43	56	64	71	80	96	106	135	138							
		24	18	24	31	38	46	53	60	68	75	101	105	125	145	149					
		28	18	22	28	34	40	47	54	62	69	79	87	106	118	131	152	164			
	3N @ 8.33	20	18	18	19	22	26	27	30	37	41	49	59	66	70	76	86	89	97	102	
		24	15	18	19	20	22	25	26	28	32	39	43	51	59	67	71	81	84	89	
		28	15	15	19	19	20	23	24	27	29	34	39	45	47	55	59	67	81	82	
	4N @ 6.25	20	15	16	16	16	20	21	23	24	27	32	36	44	46	52	54	58	74	81	
		24	16	16	16	17	17	20	24	24	26	32	36	40	45	48	53	54	68	79	
		28	15	18	20	25	29	35	39	42	49	55	70	78	93	99	109	119	134	135	
5N @ 5.00	20	15	16	19	21	26	29	33	37	40	50	57	64	72	88	97	100	106	120		
	24	15	15	17	20	24	25	29	34	37	43	51	58	66	72	89	90	101	102		
	28	16	16	17	19	21	25	28	32	35	40	49	54	54	60	69	79	86	91	96	
6N @ 4.17	20	15	18	25	31	38	43	51	55	58	73	93	100	109	125	134					
	24	15	17	23	26	32	36	42	47	53	61	75	81	98	102	112	129	140			
	28	16	16	20	24	28	31	37	41	47	56	62	72	79	93	101	106	117	125		
6N @ 4.17	20	16	17	18	22	26	28	31	36	39	48	54	64	69	75	88	96	101	108		
	24	16	24	29	38	45	55	58	69	78	94	104	116	134							
	28	16	20	25	31	37	44	50	56	64	75	97	99	107	118	138					

8N @ 3.12	28	16	18	23	28	32	38	44	51	55	67	73	87	101	104	120	134	143	145
	32	16	18	22	26	30	34	39	44	50	61	69	77	89	102	105	113	127	148
	36	16	18	24	25	30	36	39	43	49	58	67	74	84	98	108	116	117	129
	20	21	29	39	48	58	70	78	94	99	115	134							
	24	19	26	33	41	50	57	65	75	81	99	118	138						
	28	18	23	30	38	44	53	60	67	75	86	103	116	127	147				
	32	18	24	28	34	39	47	54	65	71	78	87	105	117	129	152	154		
	36	18	22	29	34	40	46	52	61	63	76	87	101	114	121	136	148	166	167
10N @ 2.50	20	26	38	49	63	78	94	100	115	134									
	24	23	33	42	54	65	75	89	99	104	130								
	28	21	30	38	48	56	64	74	84	101	109	134	147						
	32	21	28	36	43	52	62	69	76	87	107	118	130	153					
	36	22	28	37	44	52	64	71	77	85	100	116	130	151	157				
3N @ 9.33	24	18	19	19	22	24	27	29	36	39	43	53	62	70	71	78	85	89	98
	28	18	18	19	20	22	25	26	28	31	39	43	46	55	61	66	76	83	86
	32	15	18	19	19	21	23	24	27	28	34	39	45	48	53	58	66	80	81
4N @ 7.00	24	15	16	20	24	27	32	38	40	48	55	62	71	82	95	104	106	120	135
	28	15	15	18	21	25	28	32	36	39	49	56	64	71	79	96	97	106	107
	32	15	15	17	20	23	25	29	33	37	43	50	58	62	70	85	90	99	102
5N @ 5.60	24	15	18	24	29	34	39	46	52	58	66	78	96	102	111	126	136		
	28	15	17	21	26	30	35	39	46	50	61	68	77	90	99	107	114	130	142
	32	16	17	20	24	27	32	37	41	44	56	62	70	80	93	102	107	112	119
6N @ 4.67	24	16	21	28	35	41	49	55	63	70	79	96	106	134	137				
	28	15	20	24	30	36	42	50	54	58	71	82	99	107	118	138	142		
	32	16	19	23	28	32	37	43	49	53	64	74	84	101	102	111	123	144	146
7N @ 4.00	24	18	24	32	41	49	56	64	74	79	96	110	135						
	28	17	22	27	35	43	51	57	62	69	82	99	108	129	140				
	32	16	21	27	31	38	44	52	55	63	74	85	102	108	123	143	146		
8N @ 3.50	24	20	28	37	48	55	64	74	79	95	105	134							
	28	18	25	32	39	50	58	65	72	81	99	108	129	141					
	32	17	24	29	38	43	53	60	64	70	86	103	113	127	147				
10N @ 2.80	24	24	36	46	57	70	79	96	102	117	137								
	28	23	30	41	50	60	69	82	99	100	120	141							
	32	21	30	38	46	55	66	71	80	93	109	126	147						

(Continued)

**TABLE C.11 (Continued)**  
**Design Guide LRFD Weight Table for Joist Girders**  
**Based on 50 ksi Yield Strength**

Girder Span (ft.)	Joist Spaces (ft.)	Girder Depth (in.)	Joist Girder Weight—Pounds per Linear Foot Factored Load on Each Panel Point (k)																	
			6.0	9.0	12.0	15.0	18.0	21.0	24.0	27.0	30.0	36.0	42.0	48.0	54.0	60.0	66.0	72.0	78.0	84.0
30	3N @ 10.00	24	18	18	21	24	27	31	35	38	40	48	58	66	71	80	92	98	117	119
		28	18	19	22	25	27	30	35	37	42	49	56	63	63	70	79	82	93	99
		32	18	19	20	22	26	28	31	32	39	46	51	57	57	64	71	73	83	84
		36	16	19	19	21	23	26	28	31	35	39	46	52	52	57	64	64	65	73
	4N @ 7.50	24	16	18	23	29	33	37	42	49	53	64	76	85	101	104	126	127	149	150
		28	15	16	21	25	30	33	37	42	45	53	61	73	81	86	103	104	126	128
		32	15	16	18	22	26	30	34	37	43	51	55	62	70	77	87	87	103	105
		36	16	16	17	22	24	27	31	34	36	46	52	59	64	74	78	88	88	91
	5N @ 6.00	24	15	19	25	30	37	43	51	55	58	73	86	96	109	125	134			
		28	15	17	23	27	32	37	44	47	53	61	75	88	97	102	112	112	128	138
		32	16	17	21	24	29	35	39	43	48	56	63	77	90	100	101	107	117	133
		36	16	17	20	24	27	31	36	40	43	51	60	70	80	86	94	94	103	110
6N @ 5.00	24	16	24	29	37	45	52	58	66	73	94	104	116	134						
	28	16	20	27	32	38	44	50	57	65	75	97	99	107	137	140				
	32	16	19	24	29	34	40	45	51	58	65	82	98	100	109	121	142	144	148	
	36	16	18	23	26	31	37	41	46	52	61	70	84	101	102	111	123	126	148	
8N @ 3.75	24	21	32	40	51	63	73	83	99	111	124	146								
	28	20	30	37	44	53	61	73	80	86	114	126	149							
	32	18	26	34	42	49	55	63	71	79	104	117	130	154	161					
	36	17	23	32	39	46	54	61	69	76	89	108	121	134	154	169				
10N @ 3.00	24	25	38	51	66	78	99	111	123	134										
	28	24	36	47	57	69	80	94	113	116	138									
	32	22	31	39	52	58	74	82	95	105	129	142								
	36	22	30	39	48	54	68	79	84	91	119	132	151							
32	3N @ 10.67	24	18	19	21	26	27	34	38	40	42	54	61	70	75	84	88	102	102	113
		28	16	17	18	24	26	28	31	34	37	43	55	60	69	70	76	85	89	93
		32	17	17	18	21	25	26	28	32	34	39	44	54	61	62	67	77	80	86
		36	15	17	19	20	23	25	26	28	30	38	40	45	51	53	58	67	81	77



4N @ 8.00	24	18	19	23	26	32	37	40	47	55	61	72	86	94	103	114	133	134	
	28	15	18	20	24	28	32	37	40	45	55	62	70	78	94	96	105	121	135
	32	15	15	20	22	25	29	32	36	39	49	56	64	71	83	82	97	102	107
	36	15	16	17	21	24	26	30	34	36	43	50	58	65	70	85	90	99	102
5N @ 6.40	24	15	20	27	33	39	44	51	57	65	77	93	100	123	133				
	28	15	18	24	28	34	39	46	52	58	66	74	96	101	110	126	137		
	32	15	17	22	26	32	35	41	46	53	61	68	77	90	99	105	114	130	142
	36	16	17	21	24	27	33	37	42	47	56	62	70	79	93	102	106	117	120
6N @ 5.33	24	17	24	31	39	47	55	61	69	76	94	103	133	134					
	28	16	21	27	35	40	48	55	60	67	79	96	105	117	137				
	32	16	20	25	30	36	42	50	54	58	71	82	99	103	118	139	142		
	36	16	19	24	28	34	38	44	49	55	66	73	84	101	102	111	123	144	146
8N @ 4.00	24	22	32	40	54	61	72	86	93	103	133								
	28	19	27	35	45	55	63	70	80	95	105	134	137						
	32	18	25	32	39	50	58	65	71	81	99	109	120	141					
	36	18	24	31	38	43	53	59	67	71	86	103	113	127	147				
4N @ 8.75	28	16	19	23	27	31	36	41	46	52	60	74	79	94	100	111	117	137	138
	32	15	18	21	24	28	33	37	39	45	53	60	73	80	92	100	106	112	127
	36	15	16	20	23	27	30	33	37	41	561	55	62	74	83	94	97	107	113
	40	15	16	17	21	26	27	30	37	38	46	52	61	64	75	90	95	96	108
5N @ 7.00	28	15	20	26	32	37	43	52	57	59	73	86	100	109	126	136			
	32	15	18	24	29	34	37	45	50	53	66	75	88	100	102	112	128	138	
	36	16	17	23	27	29	35	40	46	48	62	68	77	90	100	104	115	131	133
	40	16	17	22	25	27	33	37	43	47	56	63	70	80	95	102	107	115	125
6N @ 5.83	28	17	24	30	37	44	52	58	65	73	93	103	115	134					
	32	16	21	27	33	38	46	53	57	65	79	96	100	117	139	140			
	36	16	20	25	31	36	41	48	54	58	70	81	99	102	113	121	142	144	
	40	16	20	24	28	34	38	44	49	55	64	77	84	101	104	115	123	145	146
7N @ 5.00	28	19	27	34	43	52	59	66	74	86	101	115	135						
	32	17	24	30	39	47	53	61	67	75	97	103	118	137					
	36	17	23	28	35	42	48	55	62	69	82	99	105	120	141	144			
	40	17	22	27	32	39	44	50	55	63	73	86	102	107	118	133	147		
8N @ 4.38	28	21	30	39	48	59	69	78	94	98	115	136							
	32	20	27	36	42	53	61	69	79	88	101	118	138						
	36	19	26	32	39	48	55	62	71	77	99	109	121	141					
	40	18	24	30	37	44	54	60	65	73	86	102	113	127	147	149			

(Continued)

**TABLE C.11 (Continued)**  
**Design Guide LRFD Weight Table for Joist Girders**  
**Based on 50 ksi Yield Strength**

Girder Span (ft.)	Girder Depth (in.)	Joist Spaces (ft.)	Joist Girder Weight—Pounds per Linear Foot Factored Load on Each Panel Point (k)																		
			6.0	9.0	12.0	15.0	18.0	21.0	24.0	27.0	30.0	36.0	42.0	48.0	54.0	60.0	66.0	72.0	78.0	84.0	
38	4N @ 9.50		16	19	21	26	31	34	39	43	48	58	67	74	87	100	101	111	127	138	
			15	17	21	24	28	33	35	39	44	53	60	74	75	93	97	106	112	123	
			15	16	20	23	27	30	34	37	41	51	55	62	74	74	83	94	98	107	109
			16	16	20	22	26	28	30	35	38	46	52	58	62	65	75	90	95	95	108
	5N @ 7.60		15	20	25	31	36	42	46	52	59	70	86	96	101	111	126	137			
			16	20	24	28	33	38	45	47	53	64	74	89	98	103	112	129	138		
			16	20	23	26	31	35	40	46	48	59	70	78	91	101	105	113	117	134	
			17	20	22	25	30	33	39	41	48	56	63	75	80	93	102	107	111	118	
	6N @ 6.33		17	24	30	35	41	49	55	62	70	86	98	105	125	136					
			16	21	27	33	39	47	50	57	61	75	89	100	107	118	141	142			
			16	21	25	31	36	40	48	55	59	71	82	99	102	109	121	143	142		
			17	20	24	29	33	38	44	49	55	64	77	84	102	104	115	123	145	147	
40	8N @ 4.75		20	29	38	47	56	64	74	86	95	105	135								
			19	28	35	42	50	57	65	76	81	101	113	138	140						
			19	26	32	40	48	55	62	67	78	100	103	121	142	144					
			20	24	30	39	47	51	57	64	71	86	102	113	127	147	149				
	4N @ 10.00		17	20	23	29	37	40	47	50	56	64	73	86	103	114	126	128	149	151	
			17	19	22	29	31	37	40	44	51	57	65	74	87	103	104	125	127	128	
			17	18	22	25	29	33	37	40	47	52	62	73	77	87	96	104	117	127	
			16	17	20	24	29	31	36	38	41	49	59	66	74	78	84	96	106	106	
	5N @ 8.00		17	17	20	24	25	30	32	37	39	48	53	59	67	78	78	85	99	106	
			15	21	26	32	38	43	52	55	62	73	86	101	109	124	134				
			16	20	24	30	34	39	45	53	55	66	74	88	102	102	112	128	138		
			16	20	24	27	32	37	41	46	51	62	68	77	90	100	105	115	130	142	
6N @ 6.67		17	20	23	29	32	37	41	49	50	58	70	82	84	99	116	118	130	141		
		17	20	23	26	31	34	40	41	50	57	68	75	85	95	100	119	120	132		
		16	24	30	38	44	52	58	65	72	93	100	115	133							
		17	22	27	34	39	47	53	60	67	79	97	102	117	137	141					

	40	16	21	26	30	36	43	48	54	62	71	82	99	103	114	130	142		
	44	17	21	24	28	36	40	47	51	55	66	78	91	102	107	116	134	142	146
	48	17	21	24	31	36	42	46	53	57	69	79	86	100	109	132	133	135	164
7N @ 5.71	32	18	26	33	43	52	58	66	74	86	101	115	135						
	36	17	24	31	39	47	53	61	67	75	97	103	117	136					
	40	17	24	29	35	43	49	55	62	69	82	99	105	119	140				
	44	20	22	28	33	39	48	55	59	64	78	92	102	111	122	143			
	48	20	23	28	36	41	48	54	61	66	80	86	108	122	134	136	164	167	
8N @ 5.00	32	21	29	38	48	58	67	78	94	96	115	135							
	36	19	27	36	46	53	60	68	80	88	102	118	137						
	40	19	25	34	39	49	58	65	72	82	99	109	120	141					
	44	21	27	33	39	47	56	63	70	75	93	103	120	136	147				
	48	20	25	32	42	47	55	62	69	80	90	104	122	136	155	170			
10N @ 4.00	32	29	39	51	64	79	92	112	123	125	149								
	36	25	36	47	60	69	81	94	103	125	150								
	40	24	36	45	56	66	75	82	96	115	129	152							
	44	23	32	41	51	60	71	82	84	99	119	143	161						
	48	23	32	41	52	58	68	76	85	94	121	134	152						

Source: Courtesy of the Steel Joist Institute, Forest, Virginia.



---

# Appendix D

## CONCRETE

---

**TABLE D.1**  
**Diameter, Area, and Unit Weight of Steel Bars**

Bar Number	3	4	5	6	7	8	9	10	11	14	18
Diameter (in.)	0.375	0.500	0.625	0.750	0.875	1.000	1.128	1.270	1.410	1.693	2.257
Area (in. <sup>2</sup> )	0.11	0.20	0.31	0.44	0.60	0.79	1.00	1.27	1.56	2.25	4.00
Unit weight per foot (lb)	0.376	0.668	1.043	1.502	2.044	2.670	3.400	4.303	5.313	7.65	13.60

---

**TABLE D.2**  
**Areas of Group of Steel Bars (in.<sup>2</sup>)**

Number of Bars	Bar Size									
	#3	#4	#5	#6	#7	#8	#9	#10	#11	
1	0.11	0.20	0.31	0.44	0.60	0.79	1.00	1.27	1.56	
2	0.22	0.40	0.62	0.88	1.20	1.58	2.00	2.54	3.12	
3	0.33	0.60	0.93	1.32	1.80	2.37	3.00	3.81	4.68	
4	0.44	0.80	1.24	1.76	2.40	3.16	4.00	5.08	6.24	
5	0.55	1.00	1.55	2.20	3.00	3.93	5.00	6.35	7.80	
6	0.66	1.20	1.86	2.64	3.60	4.74	6.00	7.62	9.36	
7	0.77	1.40	2.17	3.08	4.20	5.53	7.00	8.89	10.9	
8	0.88	1.60	2.48	3.52	4.80	6.32	8.00	10.2	12.5	
9	0.99	1.80	2.79	3.96	5.40	7.11	9.00	11.4	14.0	
10	1.10	2.00	3.10	4.40	6.00	7.90	10.0	12.7	15.6	
11	1.21	2.20	3.41	4.84	6.60	8.69	11.0	14.0	17.2	
12	1.32	2.40	3.72	5.28	7.20	9.48	12.0	15.2	18.7	
13	1.43	2.60	4.03	5.72	7.80	10.3	13.0	16.5	20.3	
14	1.54	2.80	4.34	6.16	8.40	11.1	14.0	17.8	21.8	
15	1.65	3.00	4.65	6.60	9.00	11.8	15.0	19.0	23.4	
16	1.76	3.20	4.96	7.04	9.60	12.6	16.0	20.3	25.0	
17	1.87	3.40	5.27	7.48	10.2	13.4	17.0	21.6	26.5	
18	1.98	3.60	5.58	7.92	10.8	14.2	18.0	22.9	28.1	
19	2.09	3.80	5.89	8.36	11.4	15.0	19.0	24.1	29.6	
20	2.20	4.00	6.20	8.80	12.0	15.8	20.0	25.4	31.2	

---

**TABLE D.3**  
**Minimum Required Beam Widths (in.)**

Number of Bars in One Layer	Bar Size							
	#3 and #4	#5	#6	#7	#8	#9	#10	#11
2	6.0	6.0	6.5	6.5	7.0	7.5	8.0	8.0
3	7.5	8.0	8.0	8.5	9.0	9.5	10.5	11.0
4	9.0	9.5	10.0	10.5	11.0	12.0	13.0	14.0
5	10.5	11.0	11.5	12.5	13.0	14.0	15.5	16.5
6	12.0	12.5	13.5	14.0	15.0	16.5	18.0	19.5
7	13.5	14.5	15.0	16.0	17.0	18.5	20.5	22.5
8	15.0	16.0	17.0	18.0	19.0	21.0	23.0	25.0
9	16.5	17.5	18.5	20.0	21.0	23.0	25.5	28.0
10	18.0	19.0	20.5	21.5	23.0	25.5	28.0	31.0

*Note:* Tabulated values based on No. 3 stirrups, minimum clear distance of 1 in., and a 1½ in. cover.

**TABLE D.4**  
**Coefficient of Resistance ( $\bar{K}$ ) versus Reinforcement Ratio ( $\rho$ ) ( $f'_c = 3,000$  psi;  $f_y = 40,000$  psi)**

$\rho$	$\bar{K}$ (ksi)	$\rho$	$\bar{K}$ (ksi)	$\rho$	$\bar{K}$ (ksi)	$\rho$	$\bar{K}$ (ksi)	$\rho$	$\bar{K}$ (ksi)	$\rho$	$\bar{K}$ (ksi)	$\epsilon_r^a$
0.0010	0.0397	0.0054	0.2069	0.0098	0.3619	0.0142	0.5047	0.0173	0.5981	0.02033	0.6836	0.00500
0.0011	0.0436	0.0055	0.2105	0.0099	0.3653	0.0143	0.5078	0.0174	0.6011	0.0204	0.6855	0.00497
0.0012	0.0476	0.0056	0.2142	0.0100	0.3686	0.0144	0.5109	0.0175	0.6040	0.0205	0.6882	0.00493
0.0013	0.0515	0.0057	0.2178	0.0101	0.3720	0.0145	0.5140	0.0176	0.6069	0.0206	0.6909	0.00489
0.0014	0.0554	0.0058	0.2214	0.0102	0.3754	0.0146	0.5171	0.0177	0.6098	0.0207	0.6936	0.00485
0.0015	0.0593	0.0059	0.2251	0.0103	0.3787	0.0147	0.5202	0.0178	0.6126	0.0208	0.6963	0.00482
0.0016	0.0632	0.0060	0.2287	0.0104	0.3821	0.0148	0.5233	0.0179	0.6155	0.0209	0.6990	0.00478
0.0017	0.0671	0.0061	0.2323	0.0105	0.3854	0.0149	0.5264	0.0180	0.6184	0.0210	0.7017	0.00474
0.0018	0.0710	0.0062	0.2359	0.0106	0.3887	0.0150	0.5294	0.0181	0.6213	0.0211	0.7044	0.00470
0.0019	0.0749	0.0063	0.2395	0.0107	0.3921	0.0151	0.5325	0.0182	0.6241	0.0212	0.7071	0.00467
0.0020	0.0788	0.0064	0.2431	0.0108	0.3954	0.0152	0.5355	0.0183	0.6270	0.0213	0.7097	0.00463
0.0021	0.0826	0.0065	0.2467	0.0109	0.3987	0.0153	0.5386	0.0184	0.6298	0.0214	0.7124	0.00460
0.0022	0.0865	0.0066	0.2503	0.0110	0.4020	0.0154	0.5416	0.0185	0.6327	0.0215	0.7150	0.00456
0.0023	0.0903	0.0067	0.2539	0.0111	0.4053	0.0155	0.5447	0.0186	0.6355	0.0216	0.7177	0.00453
0.0024	0.0942	0.0068	0.2575	0.0112	0.4086	0.0156	0.5477	0.0187	0.6383	0.0217	0.7203	0.00449
0.0025	0.0980	0.0069	0.2611	0.0113	0.4119	0.0157	0.5507	0.0188	0.6412	0.0218	0.7230	0.00446
0.0026	0.1019	0.0070	0.2646	0.0114	0.4152	0.0158	0.5537	0.0189	0.6440	0.0219	0.7256	0.00442
0.0027	0.1057	0.0071	0.2682	0.0115	0.4185	0.0159	0.5567	0.0190	0.6468	0.0220	0.7282	0.00439
0.0028	0.1095	0.0072	0.2717	0.0116	0.4218	0.0160	0.5597	0.0191	0.6496	0.0221	0.7308	0.00436
0.0029	0.1134	0.0073	0.2753	0.0117	0.4251	0.0161	0.5627	0.0192	0.6524	0.0222	0.7334	0.00432
0.0030	0.1172	0.0074	0.2788	0.0118	0.4283	0.0162	0.5657	0.0193	0.6552	0.0223	0.7360	0.00429
0.0031	0.1210	0.0075	0.2824	0.0119	0.4316	0.0163	0.5687	0.0194	0.6580	0.0224	0.7386	0.00426
0.0032	0.1248	0.0076	0.2859	0.0120	0.4348	0.0164	0.5717	0.0195	0.6608	0.0225	0.7412	0.00423
0.0033	0.1286	0.0077	0.2894	0.0121	0.4381	0.0165	0.5746	0.0196	0.6635	0.0226	0.7438	0.00419
0.0034	0.1324	0.0078	0.2929	0.0122	0.4413	0.0166	0.5776	0.0197	0.6663	0.0227	0.7464	0.00416
0.0035	0.1362	0.0079	0.2964	0.0123	0.4445	0.0167	0.5805	0.0198	0.6691	0.0228	0.7490	0.00413
0.0036	0.1399	0.0080	0.2999	0.0124	0.4478	0.0168	0.5835	0.0199	0.6718	0.0229	0.7515	0.00410
0.0037	0.1437	0.0081	0.3034	0.0125	0.4510	0.0169	0.5864	0.0200	0.6746	0.0230	0.7541	0.00407

(Continued)

**TABLE D.4 (Continued)**  
**Coefficient of Resistance ( $\bar{K}$ ) versus Reinforcement Ratio ( $\rho$ ) ( $f'_c = 3,000$  psi;  $f_y = 40,000$  psi)**

$\rho$	$\bar{K}$ (ksi)	$\rho$	$\bar{K}$ (ksi)	$\rho$	$\bar{K}$ (ksi)	$\rho$	$\bar{K}$ (ksi)	$\rho$	$\bar{K}$ (ksi)	$\rho$	$\bar{K}$ (ksi)	$\epsilon_r^a$
0.0038	0.1475	0.0082	0.3069	0.0126	0.4542	0.0170	0.5894	0.0201	0.6773	0.0231	0.7567	0.00404
0.0039	0.1512	0.0083	0.3104	0.0127	0.4574	0.0171	0.5923	0.0202	0.6800	0.0232	0.7592	0.00401
0.0040	0.1550	0.0084	0.3139	0.0128	0.4606	0.0172	0.5952	0.0203	0.6828	0.02323	0.7600	0.00400
0.0041	0.1587	0.0085	0.3173	0.0129	0.4638							
0.0042	0.1625	0.0086	0.3208	0.0130	0.4670							
0.0043	0.1662	0.0087	0.3243	0.0131	0.4702							
0.0044	0.1699	0.0088	0.3277	0.0132	0.4733							
0.0045	0.1736	0.0089	0.3311	0.0133	0.4765							
0.0046	0.1774	0.0090	0.3346	0.0134	0.4797							
0.0047	0.1811	0.0091	0.3380	0.0135	0.4828							
0.0048	0.1848	0.0092	0.3414	0.0136	0.4860							
0.0049	0.1885	0.0093	0.3449	0.0137	0.4891							
0.0050	0.1922	0.0094	0.3483	0.0138	0.4923							
0.0051	0.1958	0.0095	0.3517	0.0139	0.4954							
0.0052	0.1995	0.0096	0.3551	0.0140	0.4985							
0.0053	0.2032	0.0097	0.3585	0.0141	0.5016							

<sup>a</sup>  $d = d_p$ , where  $d_p$  is distance from extreme compression fiber to the outermost steel layer. For single layer steel,  $d_p = d$ .



**TABLE D.5**  
**Coefficient of Resistance ( $\bar{K}$ ) ( $f'_c = 3,000$  psi,  $f_y = 50,000$  psi)**

$\rho$	$\bar{K}$ (ksi)	$\rho$	$\bar{K}$ (ksi)	$\rho$	$\bar{K}$ (ksi)	$\rho$	$\bar{K}$ (ksi)	$\rho$	$\bar{K}$ (ksi)	$\epsilon_t^a$
0.0020	0.098	0.0056	0.265	0.0092	0.418	0.0128	0.559	0.0163	0.685	0.0050
0.0021	0.103	0.0057	0.269	0.0093	0.422	0.0129	0.563	0.0164	0.688	0.0049
0.0022	0.108	0.0058	0.273	0.0094	0.427	0.0130	0.567	0.0165	0.692	0.0049
0.0023	0.112	0.0059	0.278	0.0095	0.431	0.0131	0.571	0.0166	0.695	0.0048
0.0024	0.117	0.0060	0.282	0.0096	0.435	0.0132	0.574	0.0167	0.698	0.0048
0.0025	0.122	0.0061	0.287	0.0097	0.439	0.0133	0.578	0.0168	0.702	0.0047
0.0026	0.127	0.0062	0.291	0.0098	0.443	0.0134	0.582	0.0169	0.705	0.0047
0.0027	0.131	0.0063	0.295	0.0099	0.447	0.0135	0.585	0.017	0.708	0.0047
0.0028	0.136	0.0064	0.300	0.0100	0.451	0.0136	0.589	0.0171	0.712	0.0046
0.0029	0.141	0.0065	0.304	0.0101	0.455	0.0137	0.593	0.0172	0.715	0.0046
0.0030	0.146	0.0066	0.309	0.0102	0.459	0.0138	0.596	0.0173	0.718	0.0045
0.0031	0.150	0.0067	0.313	0.0103	0.463	0.0139	0.600	0.0174	0.722	0.0045
0.0032	0.155	0.0068	0.317	0.0104	0.467	0.0140	0.604	0.0175	0.725	0.0044
0.0033	0.159	0.0069	0.322	0.0105	0.471	0.0141	0.607	0.0176	0.728	0.0044
0.0034	0.164	0.0070	0.326	0.0106	0.475	0.0142	0.611	0.0177	0.731	0.0043
0.0035	0.169	0.0071	0.330	0.0107	0.479	0.0143	0.614	0.0178	0.735	0.0043
0.0036	0.174	0.0072	0.334	0.0108	0.483	0.0144	0.618	0.0179	0.738	0.0043
0.0037	0.178	0.0073	0.339	0.0109	0.487	0.0145	0.622	0.018	0.741	0.0042
0.0038	0.183	0.0074	0.343	0.0110	0.491	0.0146	0.625	0.0181	0.744	0.0042
0.0039	0.187	0.0075	0.347	0.0111	0.494	0.0147	0.629	0.0182	0.748	0.0041
0.0040	0.192	0.0076	0.352	0.0112	0.498	0.0148	0.632	0.0183	0.751	0.0041
0.0041	0.197	0.0077	0.356	0.0113	0.502	0.0149	0.636	0.0184	0.754	0.0041
0.0042	0.201	0.0078	0.360	0.0114	0.506	0.0150	0.639	0.0185	0.757	0.0040
0.0043	0.206	0.0079	0.364	0.0115	0.510	0.0151	0.643	0.0186	0.760	0.0040
0.0044	0.210	0.0080	0.368	0.0116	0.514	0.0152	0.646			
0.0045	0.215	0.0081	0.373	0.0117	0.518	0.0153	0.650			
0.0046	0.219	0.0082	0.377	0.0118	0.521	0.0154	0.653			
0.0047	0.224	0.0083	0.381	0.0119	0.525	0.0155	0.657			
0.0048	0.229	0.0084	0.385	0.0120	0.529	0.0156	0.660			
0.0049	0.233	0.0085	0.389	0.0121	0.533	0.0157	0.664			
0.0050	0.238	0.0086	0.394	0.0122	0.537	0.0158	0.667			
0.0051	0.242	0.0087	0.398	0.0123	0.541	0.0159	0.671			
0.0052	0.247	0.0088	0.402	0.0124	0.544	0.0160	0.674			
0.0053	0.251	0.0089	0.406	0.0125	0.548	0.0161	0.677			
0.0054	0.256	0.0090	0.410	0.0126	0.552	0.0162	0.681			
0.0055	0.260	0.0091	0.414	0.0127	0.556					

<sup>a</sup>  $d = d_p$ , where  $d_p$  is distance from extreme compression fiber to the outermost steel layer. For single layer steel,  $d_p = d$ .

**TABLE D.6**  
**Coefficient of Resistance ( $\bar{K}$ ) versus Reinforcement Ratio ( $\rho$ )**  
**( $f'_c = 3,000$  psi;  $f_y = 60,000$  psi)**

$\rho$	$\bar{K}$ (ksi)	$\rho$	$\bar{K}$ (ksi)	$\rho$	$\bar{K}$ (ksi)	$\varepsilon_t^a$
0.0010	0.0593	0.0059	0.3294	0.0108	0.5657	
0.0011	0.0651	0.0060	0.3346	0.0109	0.5702	
0.0012	0.0710	0.0061	0.3397	0.0110	0.5746	
0.0013	0.0768	0.0062	0.3449	0.0111	0.5791	
0.0014	0.0826	0.0063	0.3500	0.0112	0.5835	
0.0015	0.0884	0.0064	0.3551	0.0113	0.5879	
0.0016	0.0942	0.0065	0.3602	0.0114	0.5923	
0.0017	0.1000	0.0066	0.3653	0.0115	0.5967	
0.0018	0.1057	0.0067	0.3703	0.0116	0.6011	
0.0019	0.1115	0.0068	0.3754	0.0117	0.6054	
0.0020	0.1172	0.0069	0.3804	0.0118	0.6098	
0.0021	0.1229	0.0070	0.3854	0.0119	0.6141	
0.0022	0.1286	0.0071	0.3904	0.0120	0.6184	
0.0023	0.1343	0.0072	0.3954	0.0121	0.6227	
0.0024	0.1399	0.0073	0.4004	0.0122	0.6270	
0.0025	0.1456	0.0074	0.4054	0.0123	0.6312	
0.0026	0.1512	0.0075	0.4103	0.0124	0.6355	
0.0027	0.1569	0.0076	0.4152	0.0125	0.6398	
0.0028	0.1625	0.0077	0.4202	0.0126	0.6440	
0.0029	0.1681	0.0078	0.4251	0.0127	0.6482	
0.0030	0.1736	0.0079	0.4300	0.0128	0.6524	
0.0031	0.1792	0.0080	0.4348	0.0129	0.6566	
0.0032	0.1848	0.0081	0.4397	0.0130	0.6608	
0.0033	0.1903	0.0082	0.4446	0.0131	0.6649	
0.0034	0.1958	0.0083	0.4494	0.0132	0.6691	
0.0035	0.2014	0.0084	0.4542	0.0133	0.6732	
0.0036	0.2069	0.0085	0.4590	0.0134	0.6773	
0.0037	0.2123	0.0086	0.4638	0.0135	0.6814	
0.0038	0.2178	0.0087	0.4686	0.01355	0.6835	0.00500
0.0039	0.2233	0.0088	0.4734	0.0136	0.6855	0.00497
0.0040	0.2287	0.0089	0.4781	0.0137	0.6896	0.00491
0.0041	0.2341	0.0090	0.4828	0.0138	0.6936	0.00485
0.0042	0.2396	0.0091	0.4876	0.0139	0.6977	0.00480
0.0043	0.2450	0.0092	0.4923	0.0140	0.7017	0.00474
0.0044	0.2503	0.0093	0.4970	0.0141	0.7057	0.00469
0.0045	0.2557	0.0094	0.5017	0.0142	0.7097	0.00463
0.0046	0.2611	0.0095	0.5063	0.0143	0.7137	0.00458
0.0047	0.2664	0.0096	0.5110	0.0144	0.7177	0.00453
0.0048	0.2717	0.0097	0.5156	0.0145	0.7216	0.00447
0.0049	0.2771	0.0098	0.5202	0.0146	0.7256	0.00442
0.0050	0.2824	0.0099	0.5248	0.0147	0.7295	0.00437
0.0051	0.2876	0.0100	0.5294	0.0148	0.7334	0.00432
0.0052	0.2929	0.0101	0.5340	0.0149	0.7373	0.00427

**TABLE D.6 (Continued)****Coefficient of Resistance ( $\bar{K}$ ) versus Reinforcement Ratio ( $\rho$ )****( $f'_c = 3,000$  psi;  $f_y = 60,000$  psi)**

$\rho$	$\bar{K}$ (ksi)	$\rho$	$\bar{K}$ (ksi)	$\rho$	$\bar{K}$ (ksi)	$\epsilon_t^a$
0.0053	0.2982	0.0102	0.5386	0.0150	0.7412	0.00423
0.0054	0.3034	0.0103	0.5431	0.0151	0.7451	0.00418
0.0055	0.3087	0.0104	0.5477	0.0152	0.7490	0.00413
0.0056	0.3139	0.0105	0.5522	0.0153	0.7528	0.00408
0.0057	0.3191	0.0106	0.5567	0.0154	0.7567	0.00404
0.0058	0.3243	0.0107	0.5612	0.01548	0.7597	0.00400

<sup>a</sup>  $d = d_n$ , where  $d_i$  is distance from extreme compression fiber to the outermost steel layer. For single layer steel,  $d_i = d$ .

**TABLE D.7**  
**Coefficient of Resistance ( $\bar{K}$ ) versus Reinforcement Ratio ( $\rho$ ) ( $f'_c = 4,000$  psi;  $f_y = 40,000$  psi)**

$\rho$	$\bar{K}$ (ksi)	$\rho$	$\bar{K}$ (ksi)	$\rho$	$\bar{K}$ (ksi)	$\rho$	$\bar{K}$ (ksi)	$\rho$	$\bar{K}$ (ksi)	$\rho$	$\bar{K}$ (ksi)	$\rho$	$\bar{K}$ (ksi)	$\rho$	$\bar{K}$ (ksi)	$\rho$	$\bar{K}$ (ksi)	$\epsilon_r^a$
0.0010	0.0398	0.0054	0.2091	0.0098	0.3694	0.0142	0.5206	0.0186	0.6626	0.0229	0.7927	0.0271	0.9113	0.0271	0.9113	0.0271	0.9113	0.00500
0.0011	0.0437	0.0055	0.2129	0.0099	0.3729	0.0143	0.5239	0.0187	0.6657	0.0230	0.7956	0.0272	0.9140	0.0272	0.9140	0.0272	0.9140	0.00497
0.0012	0.0477	0.0056	0.2166	0.0100	0.3765	0.0144	0.5272	0.0188	0.6688	0.0231	0.7985	0.0273	0.9167	0.0273	0.9167	0.0273	0.9167	0.00494
0.0013	0.0516	0.0057	0.2204	0.0101	0.3800	0.0145	0.5305	0.0189	0.6720	0.0232	0.8014	0.0274	0.9194	0.0274	0.9194	0.0274	0.9194	0.00491
0.0014	0.0555	0.0058	0.2241	0.0102	0.3835	0.0146	0.5338	0.0190	0.6751	0.0233	0.8043	0.0275	0.9221	0.0275	0.9221	0.0275	0.9221	0.00488
0.0015	0.0595	0.0059	0.2278	0.0103	0.3870	0.0147	0.5372	0.0191	0.6782	0.0234	0.8072	0.0276	0.9248	0.0276	0.9248	0.0276	0.9248	0.00485
0.0016	0.0634	0.0060	0.2315	0.0104	0.3906	0.0148	0.5405	0.0192	0.6813	0.0235	0.8101	0.0277	0.9275	0.0277	0.9275	0.0277	0.9275	0.00482
0.0017	0.0673	0.0061	0.2352	0.0105	0.3941	0.0149	0.5438	0.0193	0.6844	0.0236	0.8130	0.0278	0.9302	0.0278	0.9302	0.0278	0.9302	0.00480
0.0018	0.0712	0.0062	0.2390	0.0106	0.3976	0.0150	0.5471	0.0194	0.6875	0.0237	0.8159	0.0279	0.9329	0.0279	0.9329	0.0279	0.9329	0.00477
0.0019	0.0752	0.0063	0.2427	0.0107	0.4011	0.0151	0.5504	0.0195	0.6905	0.0238	0.8188	0.0280	0.9356	0.0280	0.9356	0.0280	0.9356	0.00474
0.0020	0.0791	0.0064	0.2464	0.0108	0.4046	0.0152	0.5536	0.0196	0.6936	0.0239	0.8217	0.0281	0.9383	0.0281	0.9383	0.0281	0.9383	0.00471
0.0021	0.0830	0.0065	0.2501	0.0109	0.4080	0.0153	0.5569	0.0197	0.6967	0.0240	0.8245	0.0282	0.9410	0.0282	0.9410	0.0282	0.9410	0.00469
0.0022	0.0869	0.0066	0.2538	0.0110	0.4115	0.0154	0.5602	0.0198	0.6998	0.0241	0.8274	0.0283	0.9436	0.0283	0.9436	0.0283	0.9436	0.00466
0.0023	0.0908	0.0067	0.2574	0.0111	0.4150	0.0155	0.5635	0.0199	0.7029	0.0242	0.8303	0.0284	0.9463	0.0284	0.9463	0.0284	0.9463	0.00463
0.0024	0.0946	0.0068	0.2611	0.0112	0.4185	0.0156	0.5667	0.0200	0.7059	0.0243	0.8331	0.0285	0.9490	0.0285	0.9490	0.0285	0.9490	0.00461
0.0025	0.0985	0.0069	0.2648	0.0113	0.4220	0.0157	0.5700	0.0201	0.7090	0.0244	0.8360	0.0286	0.9516	0.0286	0.9516	0.0286	0.9516	0.00458
0.0026	0.1024	0.0070	0.2685	0.0114	0.4254	0.0158	0.5733	0.0202	0.7120	0.0245	0.8388	0.0287	0.9543	0.0287	0.9543	0.0287	0.9543	0.00455
0.0027	0.1063	0.0071	0.2721	0.0115	0.4289	0.0159	0.5765	0.0203	0.7151	0.0246	0.8417	0.0288	0.9569	0.0288	0.9569	0.0288	0.9569	0.00453
0.0028	0.1102	0.0072	0.2758	0.0116	0.4323	0.0160	0.5798	0.0204	0.7181	0.0247	0.8445	0.0289	0.9596	0.0289	0.9596	0.0289	0.9596	0.00450
0.0029	0.1140	0.0073	0.2795	0.0117	0.4358	0.0161	0.5830	0.0205	0.7212	0.0248	0.8473	0.0290	0.9622	0.0290	0.9622	0.0290	0.9622	0.00447
0.0030	0.1179	0.0074	0.2831	0.0118	0.4392	0.0162	0.5863	0.0206	0.7242	0.0249	0.8502	0.0291	0.9648	0.0291	0.9648	0.0291	0.9648	0.00445
0.0031	0.1217	0.0075	0.2868	0.0119	0.4427	0.0163	0.5895	0.0207	0.7272	0.0250	0.8530	0.0292	0.9675	0.0292	0.9675	0.0292	0.9675	0.00442
0.0032	0.1256	0.0076	0.2904	0.0120	0.4461	0.0164	0.5927	0.0208	0.7302	0.0251	0.8558	0.0293	0.9701	0.0293	0.9701	0.0293	0.9701	0.00440
0.0033	0.1294	0.0077	0.2941	0.0121	0.4495	0.0165	0.5959	0.0209	0.7333	0.0252	0.8586	0.0294	0.9727	0.0294	0.9727	0.0294	0.9727	0.00437
0.0034	0.1333	0.0078	0.2977	0.0122	0.4530	0.0166	0.5992	0.0210	0.7363	0.0253	0.8615	0.0295	0.9753	0.0295	0.9753	0.0295	0.9753	0.00435
0.0035	0.1371	0.0079	0.3013	0.0123	0.4564	0.0167	0.6024	0.0211	0.7393	0.0254	0.8643	0.0296	0.9779	0.0296	0.9779	0.0296	0.9779	0.00432
0.0036	0.1410	0.0080	0.3049	0.0124	0.4598	0.0168	0.6056	0.0212	0.7423	0.0255	0.8671	0.0297	0.9805	0.0297	0.9805	0.0297	0.9805	0.00430
0.0037	0.1448	0.0081	0.3086	0.0125	0.4632	0.0169	0.6088	0.0213	0.7453	0.0256	0.8699	0.0298	0.9831	0.0298	0.9831	0.0298	0.9831	0.00427
0.0038	0.1486	0.0082	0.3122	0.0126	0.4666	0.0170	0.6120	0.0214	0.7483	0.0257	0.8727	0.0299	0.9857	0.0299	0.9857	0.0299	0.9857	0.00425

0.0039	0.1524	0.0083	0.3158	0.0127	0.4701	0.0171	0.6152	0.0215	0.7513	0.0258	0.8754	0.0300	0.9883	0.00423
0.0040	0.1562	0.0084	0.3194	0.0128	0.4735	0.0172	0.6184	0.0216	0.7543	0.0259	0.8782	0.0301	0.9909	0.00420
0.0041	0.1600	0.0085	0.3230	0.0129	0.4768	0.0173	0.6216	0.0217	0.7572	0.0260	0.8810	0.0302	0.9935	0.00418
0.0042	0.1638	0.0086	0.3266	0.0130	0.4802	0.0174	0.6248	0.0218	0.7602	0.0261	0.8838	0.0303	0.9961	0.00415
0.0043	0.1676	0.0087	0.3302	0.0131	0.4836	0.0175	0.6279	0.0219	0.7632	0.0262	0.8865	0.0304	0.9986	0.00413
0.0044	0.1714	0.0088	0.3338	0.0132	0.4870	0.0176	0.6311	0.0220	0.7662	0.0263	0.8893	0.0305	1.0012	0.00411
0.0045	0.1752	0.0089	0.3374	0.0133	0.4904	0.0177	0.6343	0.0221	0.7691	0.0264	0.8921	0.0306	1.0038	0.00408
0.0046	0.1790	0.0090	0.3409	0.0134	0.4938	0.0178	0.6375	0.0222	0.7721	0.0265	0.8948	0.0307	1.0063	0.00406
0.0047	0.1828	0.0091	0.3445	0.0135	0.4971	0.0179	0.6406	0.0223	0.7750	0.0266	0.8976	0.0308	1.0089	0.00404
0.0048	0.1866	0.0092	0.3481	0.0136	0.5005	0.0180	0.6438	0.0224	0.7780	0.0267	0.9003	0.0309	1.0114	0.00401
0.0049	0.1904	0.0093	0.3517	0.0137	0.5038	0.0181	0.6469	0.0225	0.7809	0.0268	0.9031	0.03096	1.0130	0.00400
0.0050	0.1941	0.0094	0.3552	0.0138	0.5072	0.0182	0.6501	0.0226	0.7839	0.0269	0.9058			
0.0051	0.1979	0.0095	0.3588	0.0139	0.5105	0.0183	0.6532	0.0227	0.7868	0.0270	0.9085			
0.0052	0.2016	0.0096	0.3623	0.0140	0.5139	0.0184	0.6563	0.0228	0.7897					
0.0053	0.2054	0.0097	0.3659	0.0141	0.5172	0.0185	0.6595							

<sup>a</sup>  $d = d_i$ , where  $d_i$  is distance from extreme compression fiber to the outermost steel layer. For single layer steel,  $d_i = d$ .



0.0049	0.236	0.0089	0.416	0.0130	0.588	0.0171	0.747	0.0212	0.894	0.0245	1.004	0.0041
0.0050	0.241	0.0090	0.420	0.0131	0.592	0.0172	0.751	0.0213	0.898	0.0246	1.008	0.0040
0.0051	0.245	0.0091	0.424	0.0132	0.596	0.0173	0.755	0.0214	0.901	0.0247	1.011	0.0040
0.0052	0.250	0.0092	0.429	0.0133	0.600	0.0174	0.758	0.0215	0.904	0.0248	1.014	0.0040
0.0053	0.255	0.0093	0.433	0.0134	0.604	0.0175	0.762					
0.0054	0.259	0.0094	0.437	0.0135	0.608	0.0176	0.766					
0.0055	0.264	0.0095	0.442	0.0136	0.612	0.0177	0.769					
0.0056	0.268	0.0096	0.446	0.0137	0.616	0.0178	0.773					
0.0057	0.273	0.0097	0.450	0.0138	0.620	0.0179	0.777					
0.0058	0.278	0.0098	0.455	0.0139	0.624	0.0180	0.780					
0.0059	0.282	0.0099	0.459	0.0140	0.628	0.0181	0.784					
0.0060	0.287	0.0100	0.463	0.0141	0.632	0.0182	0.788					
		0.0101	0.467	0.0142	0.636	0.0183	0.791					

<sup>a</sup>  $d = d_c$ , where  $d_c$  is distance from extreme compression fiber to the outermost steel layer. For single layer steel,  $d_c = d$ .

**TABLE D.9**  
**Coefficient of Resistance ( $\bar{K}$ ) versus Reinforcement Ratio ( $\rho$ ) ( $f'_c = 4,000$  psi;  $f_y = 60,000$  psi)**

$\rho$	$\bar{K}$ (ksi)	$\rho$	$\bar{K}$ (ksi)	$\rho$	$\bar{K}$ (ksi)	$\rho$	$\bar{K}$ (ksi)	$\rho$	$\bar{K}$ (ksi)	$\rho$	$\bar{K}$ (ksi)	$\rho$	$\bar{K}$ (ksi)	$\rho$	$\bar{K}$ (ksi)	$\rho$	$\bar{K}$ (ksi)	$\rho$	$\bar{K}$ (ksi)	$\epsilon^a$	
0.0010	0.0595	0.0039	0.2259	0.0068	0.3835	0.0097	0.5322	0.0126	0.6720	0.0154	0.7985	0.01806	0.9110	0.01806	0.9110	0.01806	0.9110	0.01806	0.9110	0.00500	
0.0011	0.0654	0.0040	0.2315	0.0069	0.3888	0.0098	0.5372	0.0127	0.6766	0.0155	0.8029	0.0181	0.9126	0.0181	0.9126	0.0181	0.9126	0.0181	0.9126	0.00498	
0.0012	0.0712	0.0041	0.2371	0.0070	0.3941	0.0099	0.5421	0.0128	0.6813	0.0156	0.8072	0.0182	0.9167	0.0182	0.9167	0.0182	0.9167	0.0182	0.9167	0.00494	
0.0013	0.0771	0.0042	0.2427	0.0071	0.3993	0.0100	0.5471	0.0129	0.6859	0.0157	0.8116	0.0183	0.9208	0.0183	0.9208	0.0183	0.9208	0.0183	0.9208	0.00490	
0.0014	0.0830	0.0043	0.2482	0.0072	0.4046	0.0101	0.5520	0.0130	0.6906	0.0158	0.8159	0.0184	0.9248	0.0184	0.9248	0.0184	0.9248	0.0184	0.9248	0.00485	
0.0015	0.0889	0.0044	0.2538	0.0073	0.4098	0.0102	0.5569	0.0131	0.6952	0.0159	0.8202	0.0185	0.9289	0.0185	0.9289	0.0185	0.9289	0.0185	0.9289	0.00481	
0.0016	0.0946	0.0045	0.2593	0.0074	0.4150	0.0103	0.5618	0.0132	0.6998	0.0160	0.8245	0.0186	0.9329	0.0186	0.9329	0.0186	0.9329	0.0186	0.9329	0.00477	
0.0017	0.1005	0.0046	0.2648	0.0075	0.4202	0.0104	0.5667	0.0133	0.7044	0.0161	0.8288	0.0187	0.9369	0.0187	0.9369	0.0187	0.9369	0.0187	0.9369	0.00473	
0.0018	0.1063	0.0047	0.2703	0.0076	0.4254	0.0105	0.5716	0.0134	0.7090	0.0162	0.8331	0.0188	0.9410	0.0188	0.9410	0.0188	0.9410	0.0188	0.9410	0.00469	
0.0019	0.1121	0.0048	0.2758	0.0077	0.4306	0.0106	0.5765	0.0135	0.7136	0.0163	0.8374	0.0189	0.9450	0.0189	0.9450	0.0189	0.9450	0.0189	0.9450	0.00465	
0.0020	0.1179	0.0049	0.2813	0.0078	0.4358	0.0107	0.5814	0.0136	0.7181	0.0164	0.8417	0.0190	0.9490	0.0190	0.9490	0.0190	0.9490	0.0190	0.9490	0.00461	
0.0021	0.1237	0.0050	0.2868	0.0079	0.4410	0.0108	0.5862	0.0137	0.7227	0.0165	0.8459	0.0191	0.9529	0.0191	0.9529	0.0191	0.9529	0.0191	0.9529	0.00457	
0.0022	0.1294	0.0051	0.2922	0.0080	0.4461	0.0109	0.5911	0.0138	0.7272	0.0166	0.8502	0.0192	0.9569	0.0192	0.9569	0.0192	0.9569	0.0192	0.9569	0.00453	
0.0023	0.1352	0.0052	0.2977	0.0081	0.4513	0.0110	0.5959	0.0139	0.7318	0.0167	0.8544	0.0193	0.9609	0.0193	0.9609	0.0193	0.9609	0.0193	0.9609	0.00449	
0.0024	0.1410	0.0053	0.3031	0.0082	0.4564	0.0111	0.6008	0.0140	0.7363	0.0168	0.8586	0.0194	0.9648	0.0194	0.9648	0.0194	0.9648	0.0194	0.9648	0.00445	
0.0025	0.1467	0.0054	0.3086	0.0083	0.4615	0.0112	0.6056	0.0141	0.7408	0.0169	0.8629	0.0195	0.9688	0.0195	0.9688	0.0195	0.9688	0.0195	0.9688	0.00441	
0.0026	0.1524	0.0055	0.3140	0.0084	0.4666	0.0113	0.6104	0.0142	0.7453	0.0170	0.8671	0.0196	0.9727	0.0196	0.9727	0.0196	0.9727	0.0196	0.9727	0.00437	
0.0027	0.1581	0.0056	0.3194	0.0085	0.4718	0.0114	0.6152	0.0143	0.7498	0.0171	0.8713	0.0197	0.9766	0.0197	0.9766	0.0197	0.9766	0.0197	0.9766	0.00434	
0.0028	0.1638	0.0057	0.3248	0.0086	0.4768	0.0115	0.6200	0.0144	0.7543	0.0172	0.8754	0.0198	0.9805	0.0198	0.9805	0.0198	0.9805	0.0198	0.9805	0.00430	
0.0029	0.1695	0.0058	0.3302	0.0087	0.4819	0.0116	0.6248	0.0145	0.7587	0.0173	0.8796	0.0199	0.9844	0.0199	0.9844	0.0199	0.9844	0.0199	0.9844	0.00426	
0.0030	0.1752	0.0059	0.3356	0.0088	0.4870	0.0117	0.6296	0.0146	0.7632	0.0174	0.8838	0.0200	0.9883	0.0200	0.9883	0.0200	0.9883	0.0200	0.9883	0.00422	
0.0031	0.1809	0.0060	0.3409	0.0089	0.4921	0.0118	0.6343	0.0147	0.7676	0.0175	0.8879	0.0201	0.9922	0.0201	0.9922	0.0201	0.9922	0.0201	0.9922	0.00419	
0.0032	0.1866	0.0061	0.3463	0.0090	0.4971	0.0119	0.6391	0.0148	0.7721	0.0176	0.8921	0.0202	0.9961	0.0202	0.9961	0.0202	0.9961	0.0202	0.9961	0.00415	
0.0033	0.1922	0.0062	0.3516	0.0091	0.5022	0.0120	0.6438	0.0149	0.7765	0.0177	0.8962	0.0203	0.9999	0.0203	0.9999	0.0203	0.9999	0.0203	0.9999	0.00412	
0.0034	0.1979	0.0063	0.3570	0.0092	0.5072	0.0121	0.6485	0.0150	0.7809	0.0178	0.9003	0.0204	1.0038	0.0204	1.0038	0.0204	1.0038	0.0204	1.0038	0.00408	
0.0035	0.2035	0.0064	0.3623	0.0093	0.5122	0.0122	0.6532	0.0151	0.7853	0.0179	0.9044	0.0205	1.0076	0.0205	1.0076	0.0205	1.0076	0.0205	1.0076	0.00405	
0.0036	0.2091	0.0065	0.3676	0.0094	0.5172	0.0123	0.6579	0.0152	0.7897	0.0180	0.9085	0.0206	1.0114	0.0206	1.0114	0.0206	1.0114	0.0206	1.0114	0.00401	
0.0037	0.2148	0.0066	0.3729	0.0095	0.5222	0.0124	0.6626	0.0153	0.7941											0.00400	
0.0038	0.2204	0.0067	0.3782	0.0096	0.5272	0.0125	0.6673														0.00400

<sup>a</sup>  $d = d_i$ , where  $d_i$  is distance from extreme compression fiber to the outermost steel layer. For single layer steel,  $d_i = d$ .



**TABLE D.10**  
**Coefficient of Resistance ( $\bar{K}$ ) versus Reinforcement Ratio ( $\rho$ ) ( $f'_c = 5,000$  psi;  $f_y = 60,000$  psi)**

$\rho$	$\bar{K}$ (ksi)	$\rho$	$\bar{K}$ (ksi)	$\rho$	$\bar{K}$ (ksi)	$\rho$	$\bar{K}$ (ksi)	$\rho$	$\bar{K}$ (ksi)	$\rho$	$\bar{K}$ (ksi)	$\rho$	$\bar{K}$ (ksi)	$\rho$	$\bar{K}$ (ksi)	$\rho$	$\bar{K}$ (ksi)	$\rho$	$\bar{K}$ (ksi)	$\epsilon_r^a$
0.0010	0.0596	0.0048	0.2782	0.0086	0.4847	0.0124	0.6789	0.0162	0.8609	0.0194	1.0047	0.02257	1.1385	0.00500	1.1385	0.02257	1.1385	0.00500	1.1385	0.00500
0.0011	0.0655	0.0049	0.2838	0.0087	0.4899	0.0125	0.6838	0.0163	0.8655	0.0195	1.0090	0.0226	1.1398	0.00499	1.1398	0.0226	1.1398	0.00499	1.1398	0.00499
0.0012	0.0714	0.0050	0.2894	0.0088	0.4952	0.0126	0.6888	0.0164	0.8701	0.0196	1.0134	0.0227	1.1438	0.00496	1.1438	0.0227	1.1438	0.00496	1.1438	0.00496
0.0013	0.0773	0.0051	0.2950	0.0089	0.5005	0.0127	0.6937	0.0165	0.8747	0.0197	1.0177	0.0228	1.1479	0.00492	1.1479	0.0228	1.1479	0.00492	1.1479	0.00492
0.0014	0.0832	0.0052	0.3005	0.0090	0.5057	0.0128	0.6986	0.0166	0.8793	0.0198	1.0220	0.0229	1.1520	0.00489	1.1520	0.0229	1.1520	0.00489	1.1520	0.00489
0.0015	0.0890	0.0053	0.3061	0.0091	0.5109	0.0129	0.7035	0.0167	0.8839	0.0199	1.0263	0.0230	1.1560	0.00485	1.1560	0.0230	1.1560	0.00485	1.1560	0.00485
0.0016	0.0949	0.0054	0.3117	0.0092	0.5162	0.0130	0.7084	0.0168	0.8885	0.0200	1.0307	0.0231	1.1601	0.00482	1.1601	0.0231	1.1601	0.00482	1.1601	0.00482
0.0017	0.1008	0.0055	0.3172	0.0093	0.5214	0.0131	0.7133	0.0169	0.8930	0.0201	1.0350	0.0232	1.1641	0.00479	1.1641	0.0232	1.1641	0.00479	1.1641	0.00479
0.0018	0.1066	0.0056	0.3227	0.0094	0.5266	0.0132	0.7182	0.0170	0.8976	0.0202	1.0393	0.0233	1.1682	0.00475	1.1682	0.0233	1.1682	0.00475	1.1682	0.00475
0.0019	0.1125	0.0057	0.3282	0.0095	0.5318	0.0133	0.7231	0.0171	0.9022	0.0203	1.0435	0.0234	1.1722	0.00472	1.1722	0.0234	1.1722	0.00472	1.1722	0.00472
0.0020	0.1183	0.0058	0.3338	0.0096	0.5370	0.0134	0.7280	0.0172	0.9067	0.0204	1.0478	0.0235	1.1762	0.00469	1.1762	0.0235	1.1762	0.00469	1.1762	0.00469
0.0021	0.1241	0.0059	0.3393	0.0097	0.5422	0.0135	0.7328	0.0173	0.9112	0.0205	1.0521	0.0236	1.1802	0.00465	1.1802	0.0236	1.1802	0.00465	1.1802	0.00465
0.0022	0.1300	0.0060	0.3448	0.0098	0.5473	0.0136	0.7377	0.0174	0.9158	0.0206	1.0563	0.0237	1.1842	0.00462	1.1842	0.0237	1.1842	0.00462	1.1842	0.00462
0.0023	0.1358	0.0061	0.3502	0.0099	0.5525	0.0137	0.7425	0.0175	0.9203	0.0207	1.0606	0.0238	1.1882	0.00459	1.1882	0.0238	1.1882	0.00459	1.1882	0.00459
0.0024	0.1416	0.0062	0.3557	0.0100	0.5576	0.0138	0.7473	0.0176	0.9248	0.0208	1.0648	0.0239	1.1922	0.00456	1.1922	0.0239	1.1922	0.00456	1.1922	0.00456
0.0025	0.1474	0.0063	0.3612	0.0101	0.5628	0.0139	0.7522	0.0177	0.9293	0.0209	1.0691	0.0240	1.1961	0.00453	1.1961	0.0240	1.1961	0.00453	1.1961	0.00453
0.0026	0.1531	0.0064	0.3667	0.0102	0.5679	0.0140	0.7570	0.0178	0.9338	0.0210	1.0733	0.0241	1.2001	0.00449	1.2001	0.0241	1.2001	0.00449	1.2001	0.00449
0.0027	0.1589	0.0065	0.3721	0.0103	0.5731	0.0141	0.7618	0.0179	0.9383	0.0211	1.0775	0.0242	1.2041	0.00446	1.2041	0.0242	1.2041	0.00446	1.2041	0.00446
0.0028	0.1647	0.0066	0.3776	0.0104	0.5782	0.0142	0.7666	0.0180	0.9428	0.0212	1.0817	0.0243	1.2080	0.00443	1.2080	0.0243	1.2080	0.00443	1.2080	0.00443
0.0029	0.1704	0.0067	0.3830	0.0105	0.5833	0.0143	0.7714	0.0181	0.9473	0.0213	1.0859	0.0244	1.2119	0.00440	1.2119	0.0244	1.2119	0.00440	1.2119	0.00440
0.0030	0.1762	0.0068	0.3884	0.0106	0.5884	0.0144	0.7762	0.0182	0.9517	0.0214	1.0901	0.0245	1.2159	0.00437	1.2159	0.0245	1.2159	0.00437	1.2159	0.00437
0.0031	0.1819	0.0069	0.3938	0.0107	0.5935	0.0145	0.7810	0.0183	0.9562	0.0215	1.0943	0.0246	1.2198	0.00434	1.2198	0.0246	1.2198	0.00434	1.2198	0.00434
0.0032	0.1877	0.0070	0.3992	0.0108	0.5986	0.0146	0.7857	0.0184	0.9606	0.0216	1.0985	0.0247	1.2237	0.00431	1.2237	0.0247	1.2237	0.00431	1.2237	0.00431
0.0033	0.1934	0.0071	0.4047	0.0109	0.6037	0.0147	0.7905	0.0185	0.9651	0.0217	1.1026	0.0248	1.2276	0.00428	1.2276	0.0248	1.2276	0.00428	1.2276	0.00428
0.0034	0.1991	0.0072	0.4100	0.0110	0.6088	0.0148	0.7952	0.0186	0.9695	0.0218	1.1068	0.0249	1.2315	0.00425	1.2315	0.0249	1.2315	0.00425	1.2315	0.00425
0.0035	0.2048	0.0073	0.4154	0.0111	0.6138	0.0149	0.8000	0.0187	0.9739	0.0219	1.1110	0.0250	1.2354	0.00423	1.2354	0.0250	1.2354	0.00423	1.2354	0.00423
0.0036	0.2105	0.0074	0.4208	0.0112	0.6189	0.0150	0.8047	0.0188	0.9783	0.0220	1.1151	0.0251	1.2393	0.00420	1.2393	0.0251	1.2393	0.00420	1.2393	0.00420
0.0037	0.2162	0.0075	0.4262	0.0113	0.6239	0.0151	0.8094	0.0189	0.9827	0.0221	1.1192	0.0252	1.2431	0.00417	1.2431	0.0252	1.2431	0.00417	1.2431	0.00417

(Continued)

**TABLE D.10 (Continued)**  
**Coefficient of Resistance ( $\bar{K}$ ) versus Reinforcement Ratio ( $\rho$ ) ( $f'_c = 5,000$  psi;  $f_y = 60,000$  psi)**

$\rho$	$\bar{K}$ (ksi)	$\rho$	$\bar{K}$ (ksi)	$\rho$	$\bar{K}$ (ksi)	$\rho$	$\bar{K}$ (ksi)	$\rho$	$\bar{K}$ (ksi)	$\rho$	$\bar{K}$ (ksi)	$\rho$	$\bar{K}$ (ksi)	$\rho$	$\bar{K}$ (ksi)	$\rho$	$\bar{K}$ (ksi)	$\epsilon_r^a$
0.0038	0.2219	0.0076	0.4315	0.0114	0.6290	0.0152	0.8142	0.0190	0.9872	0.0222	1.1234	0.0253	1.2470	0.0253	1.2470	0.0253	1.2470	0.00414
0.0039	0.2276	0.0077	0.4369	0.0115	0.6340	0.0153	0.8189	0.0191	0.9916	0.0223	1.1275	0.0254	1.2509	0.0254	1.2509	0.0254	1.2509	0.00411
0.0040	0.2332	0.0078	0.4422	0.0116	0.6390	0.0154	0.8236	0.0192	0.9959	0.0224	1.1316	0.0255	1.2547	0.0255	1.2547	0.0255	1.2547	0.00408
0.0041	0.2389	0.0079	0.4476	0.0117	0.6440	0.0155	0.8283	0.0193	1.0003	0.0225	1.1357	0.0256	1.2585	0.0256	1.2585	0.0256	1.2585	0.00406
0.0042	0.2445	0.0080	0.4529	0.0118	0.6490	0.0156	0.8329					0.0257	1.2624	0.0257	1.2624	0.0257	1.2624	0.00403
0.0043	0.2502	0.0081	0.4582	0.0119	0.6540	0.0157	0.8376					0.0258	1.2662	0.0258	1.2662	0.0258	1.2662	0.00400
0.0044	0.2558	0.0082	0.4635	0.0120	0.6590	0.0158	0.8423											
0.0045	0.2614	0.0083	0.4688	0.0121	0.6640	0.0159	0.8469											
0.0046	0.2670	0.0084	0.4741	0.0122	0.6690	0.0160	0.8516											
0.0047	0.2726	0.0085	0.4794	0.0123	0.6739	0.0161	0.8562											

<sup>a</sup>  $d = d_c$ , where  $d_c$  is distance from extreme compression fiber to the outermost steel layer. For single layer steel,  $d_c = d$ .

**TABLE D.11****Values of  $\rho$  Balanced,  $\rho$  for  $\epsilon_t = 0.005$ , and  $\rho$  Minimum for Flexure**

$f_y$	$f'_c$	3,000 psi	4,000 psi	5,000 psi	6,000 psi
		$\beta_1 = 0.85$	$\beta_1 = 0.85$	$\beta_1 = 0.80$	$\beta_1 = 0.75$
Grade 40	$\rho$ balanced	0.0371	0.0495	0.0582	0.0655
40,000 psi	$\rho$ when $\epsilon_t = 0.005$	0.0203	0.0271	0.0319	0.0359
	$\rho$ min for flexure	0.0050	0.0050	0.0053	0.0058
Grade 50	$\rho$ balanced	0.0275	0.0367	0.0432	0.0486
50,000 psi	$\rho$ when $\epsilon_t = 0.005$	0.0163	0.0217	0.0255	0.0287
	$\rho$ min for flexure	0.0040	0.0040	0.0042	0.0046
Grade 60	$\rho$ balanced	0.0214	0.0285	0.0335	0.0377
60,000 psi	$\rho$ when $\epsilon_t = 0.005$	0.0136	0.0181	0.0212	0.0239
	$\rho$ min for flexure	0.0033	0.0033	0.0035	0.0039
Grade 75	$\rho$ balanced	0.0155	0.0207	0.0243	0.0274
75,000 psi	$\rho$ when $\epsilon_t = 0.005$	0.0108	0.0144	0.0170	0.0191
	$\rho$ min for flexure	0.0027	0.0027	0.0028	0.0031

**TABLE D.12****Areas of Steel Bars per Foot of Slab (in.<sup>2</sup>)**

Bar Spacing (in.)	Bar Size								
	#3	#4	#5	#6	#7	#8	#9	#10	#11
2	0.66	1.20	1.86						
2½	0.53	0.96	1.49	2.11					
3	0.44	0.80	1.24	1.76	2.40	3.16	4.00		
3½	0.38	0.69	1.06	1.51	2.06	2.71	3.43	4.35	
4	0.33	0.60	0.93	1.32	1.80	2.37	3.00	3.81	4.68
4½	0.29	0.53	0.83	1.17	1.60	2.11	2.67	3.39	4.16
5	0.26	0.48	0.74	1.06	1.44	1.90	2.40	3.05	3.74
5½	0.24	0.44	0.68	0.96	1.31	1.72	2.18	2.77	3.40
6	0.22	0.40	0.62	0.88	1.20	1.58	2.00	2.54	3.12
6½	0.20	0.37	0.57	0.81	1.11	1.46	1.85	2.34	2.88
7	0.19	0.34	0.53	0.75	1.03	1.35	1.71	2.18	2.67
7½	0.18	0.32	0.50	0.70	0.96	1.26	1.60	2.03	2.50
8	0.16	0.30	0.46	0.66	0.90	1.18	1.50	1.90	2.34
9	0.15	0.27	0.41	0.59	0.80	1.05	1.33	1.69	2.08
10	0.13	0.24	0.37	0.53	0.72	0.95	1.20	1.52	1.87
11	0.12	0.22	0.34	0.48	0.65	0.86	1.09	1.39	1.70
12	0.11	0.20	0.31	0.44	0.60	0.79	1.00	1.27	1.56
13	0.10	0.18	0.29	0.41	0.55	0.73	0.92	1.17	1.44
14	0.09	0.17	0.27	0.38	0.51	0.68	0.86	1.09	1.34
15	0.09	0.16	0.25	0.35	0.48	0.64	0.80	1.02	1.25
16	0.08	0.15	0.23	0.33	0.45	0.59	0.75	0.95	1.17
17	0.08	0.14	0.22	0.31	0.42	0.56	0.71	0.90	1.10
18	0.07	0.13	0.21	0.29	0.40	0.53	0.67	0.85	1.04

**TABLE D.13**  
**Size and Pitch of Spirals**

Diameter of Column (in.)	Out to Out of Spiral (in.)	$f'_c$			
		2,500	3,000	4,000	5,000
<b><math>f_y = 40,000</math></b>					
14, 15	11, 12	$\frac{3}{8}-2$	$\frac{3}{8}-1\frac{3}{4}$	$\frac{1}{2}-2\frac{1}{2}$	$\frac{1}{2}-1\frac{3}{4}$
16	13	$\frac{3}{8}-2$	$\frac{3}{8}-1\frac{3}{4}$	$\frac{1}{2}-2\frac{1}{2}$	$\frac{1}{2}-2$
17-19	14-16	$\frac{3}{8}-2\frac{1}{4}$	$\frac{3}{8}-1\frac{3}{4}$	$\frac{1}{2}-2\frac{1}{2}$	$\frac{1}{2}-2$
20-23	17-20	$\frac{3}{8}-2\frac{1}{4}$	$\frac{3}{8}-1\frac{3}{4}$	$\frac{1}{2}-2\frac{1}{2}$	$\frac{1}{2}-2$
24-30	21-27	$\frac{3}{8}-2\frac{1}{4}$	$\frac{3}{8}-2$	$\frac{1}{2}-2\frac{1}{2}$	$\frac{1}{2}-2$
<b><math>f_y = 60,000</math></b>					
14, 15	11, 12	$\frac{1}{4}-1\frac{3}{4}$	$\frac{3}{8}-2\frac{3}{4}$	$\frac{3}{8}-2$	$\frac{1}{2}-2\frac{3}{4}$
16-23	13-20	$\frac{1}{4}-1\frac{3}{4}$	$\frac{3}{8}-2\frac{3}{4}$	$\frac{3}{8}-2$	$\frac{1}{2}-3$
24-29	21-26	$\frac{1}{4}-1\frac{3}{4}$	$\frac{3}{8}-3$	$\frac{3}{8}-2\frac{1}{4}$	$\frac{1}{2}-3$
30	17	$\frac{1}{4}-1\frac{3}{4}$	$\frac{3}{8}-3$	$\frac{3}{8}-2\frac{1}{4}$	$\frac{1}{2}-3\frac{1}{4}$

**TABLE D.14**  
**Maximum Number of Bars in One Row**

1½ bar diameters  
 or 1½ in.



Recommended Spiral or Tie Bar Number	Core Size (in.) = Column Size - 2 X Cover	Circular Area (in. <sup>2</sup> )	Bar Size											Square Area (in. <sup>2</sup> )				
			#5	#6	#7	#8	#9	#10	#11 <sup>a</sup>	#5	#6	#7	#8		#9	#10	#11 <sup>a</sup>	
3	9	63.6	8	7	7	6	—	—	—	—	—	—	—	—	—	—	81	
	10	78.5	10	9	8	7	6	—	—	—	—	—	—	—	—	—	100	
	11	95.0	11	10	9	8	7	6	—	—	—	—	—	—	—	—	121	
	12	113.1	12	11	10	9	8	7	6	—	—	—	—	—	—	—	144	
	13	132.7	13	12	11	10	8	7	6	—	—	—	—	—	—	—	169	
	14	153.9	14	13	12	11	9	8	7	6	—	—	—	—	—	—	196	
	15	176.7	15	14	13	12	10	9	8	7	6	—	—	—	—	—	225	
	4	16	201.1	16	15	14	12	11	9	8	—	—	—	—	—	—	—	256
		17	227.0	18	16	15	13	12	10	9	8	—	—	—	—	—	—	289
		18	254.5	19	17	15	14	12	11	10	—	—	—	—	—	—	—	324
		19	283.5	20	18	16	15	13	11	10	—	—	—	—	—	—	—	361
		20	314.2	21	19	17	16	14	12	11	10	—	—	—	—	—	—	400
		21	346.4	22	20	18	17	15	13	11	10	—	—	—	—	—	—	441
		22	380.1	23	21	19	18	15	14	12	11	10	—	—	—	—	—	484
		23	415.5	24	22	21	19	16	14	13	12	11	10	—	—	—	—	529
24		452.4	25	23	21	20	17	15	14	13	12	11	10	—	—	—	576	
25		490.9	26	24	22	20	18	16	15	14	13	12	11	10	—	—	625	
26		530.9	28	25	23	21	19	16	15	14	13	12	11	10	—	—	676	
27		572.6	29	26	24	22	19	17	15	14	13	12	11	10	—	—	729	
5		30	616.5	30	27	25	23	20	18	16	15	14	13	12	11	10	—	900
		32	672.0	32	28	26	24	21	19	17	15	14	13	12	11	10	—	1024
		34	729.0	34	30	28	26	23	20	18	16	15	14	13	12	11	10	1156
	36	786.0	36	32	30	28	24	21	19	17	15	14	13	12	11	10	1296	
	38	844.0	38	34	32	30	26	23	20	18	16	15	14	13	12	11	1444	
	40	903.0	40	36	34	32	28	24	21	19	17	15	14	13	12	11	1600	
	42	963.0	42	38	36	34	30	26	23	20	18	16	15	14	13	12	1764	
	44	1024.0	44	40	38	36	32	28	24	21	19	17	15	14	13	12	1936	
	46	1086.0	46	42	40	38	34	30	26	23	20	18	16	15	14	13	2116	
	48	1149.0	48	44	42	40	36	32	28	24	21	19	17	15	14	13	2304	
	50	1213.0	50	46	44	42	38	34	30	26	23	20	18	16	15	14	2500	
	52	1278.0	52	48	46	44	40	36	32	28	24	21	19	17	15	14	2704	
	54	1344.0	54	50	48	46	42	38	34	30	26	23	20	18	16	15	2916	
	56	1411.0	56	52	50	48	44	40	36	32	28	24	21	19	17	15	3136	
	58	1479.0	58	54	52	50	46	42	38	34	30	26	23	20	18	16	3364	

<sup>a</sup> Use No. 4 tie for No. 11 or larger longitudinal reinforcement.

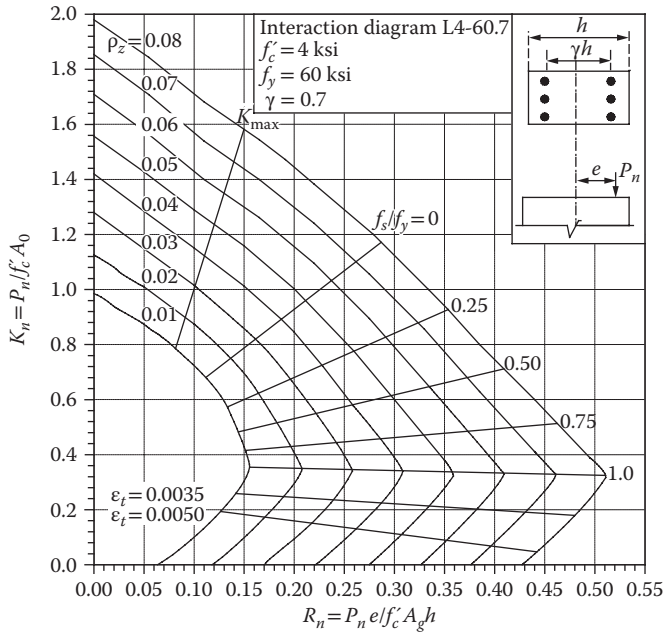


FIGURE D.15 Column interaction diagram for tied column with bars on end faces only. (Courtesy of the American Concrete Institute, Farmington Hills, MI.)

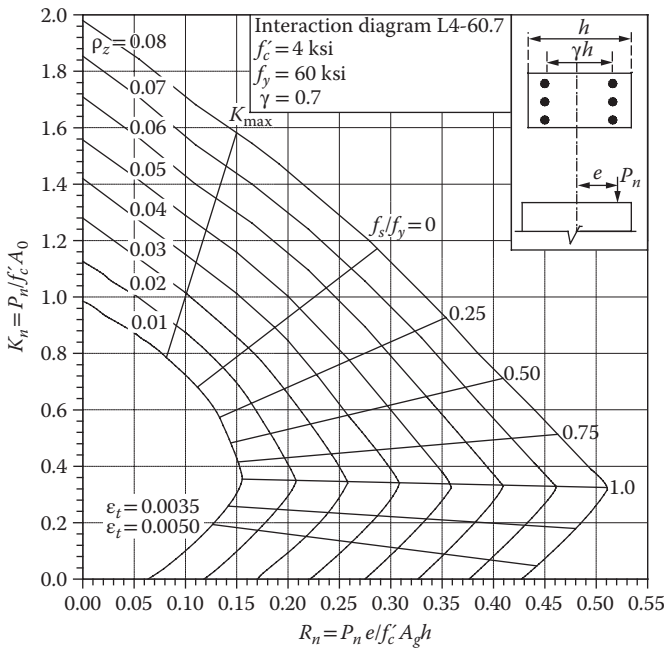
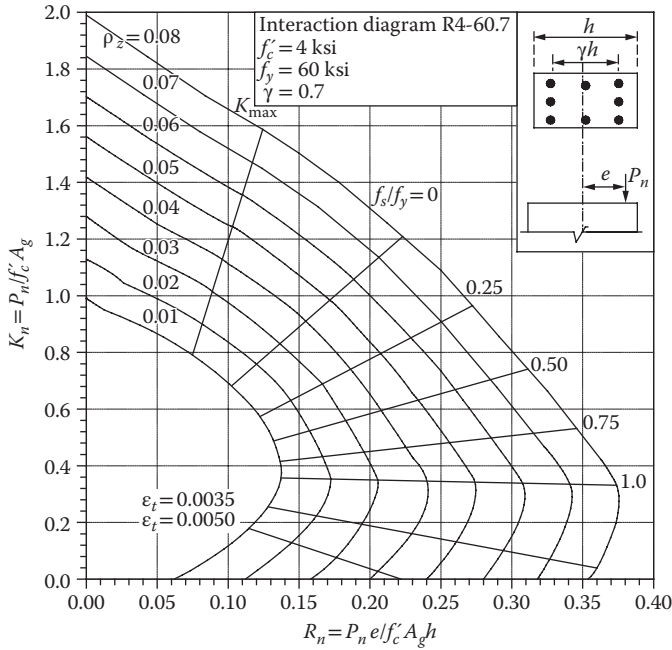
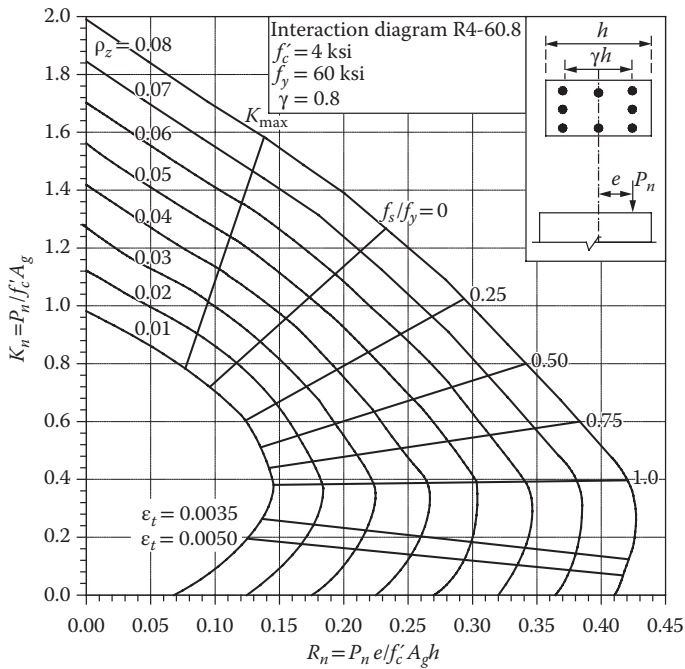


FIGURE D.16 Column interaction diagram for tied column with bars on end faces only. (Courtesy of the American Concrete Institute, Farmington Hills, MI.)



**FIGURE D.17** Column interaction diagram for tied column with bars on all faces. (Courtesy of the American Concrete Institute, Farmington Hills, MI.)



**FIGURE D.18** Column interaction diagram for tied column with bars on all faces. (Courtesy of the American Concrete Institute, Farmington Hills, MI.)

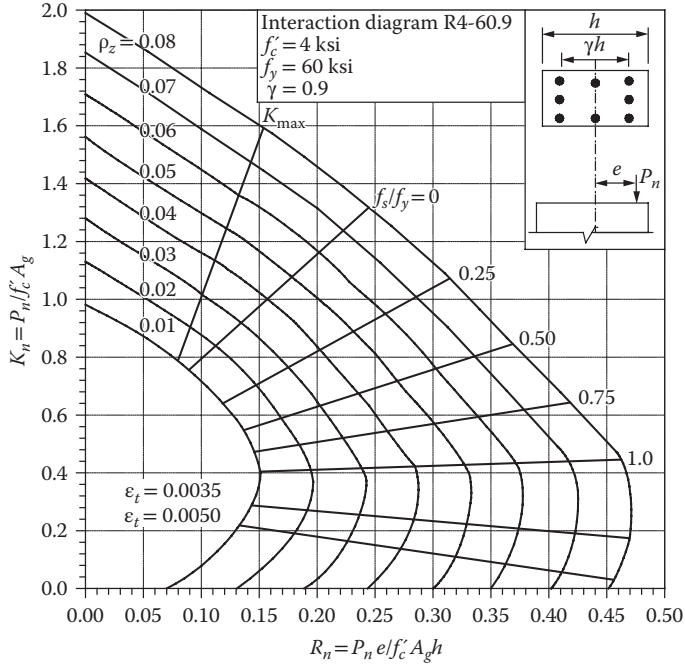


FIGURE D.19 Column interaction diagram for tied column with bars on all faces. (Courtesy of the American Concrete Institute, Farmington Hills, MI.)

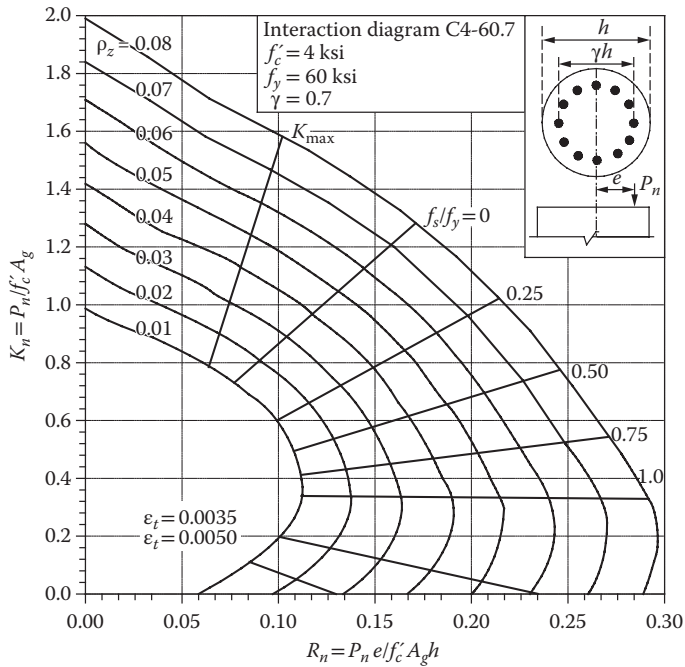


FIGURE D.20 Column interaction diagram for circular spiral column. (Courtesy of the American Concrete Institute, Farmington Hills, MI.)



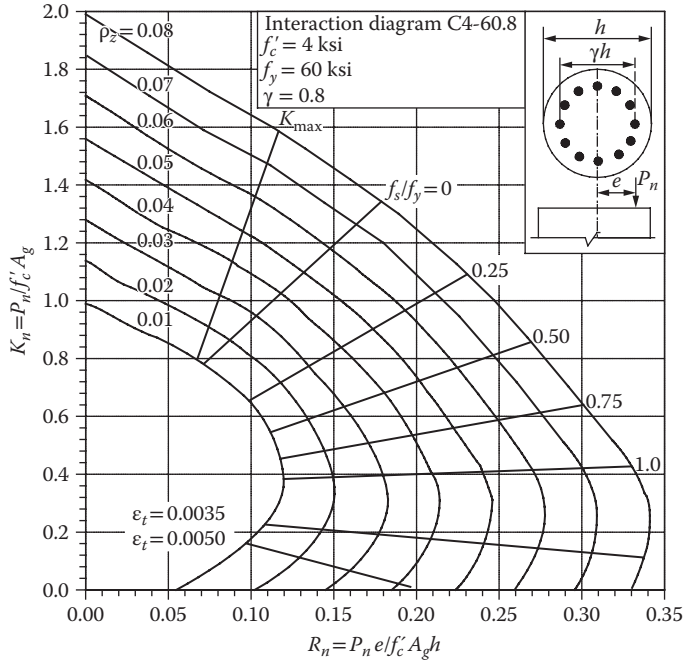


FIGURE D.21 Column interaction diagram for circular spiral column. (Courtesy of the American Concrete Institute, Farmington Hills, MI.)

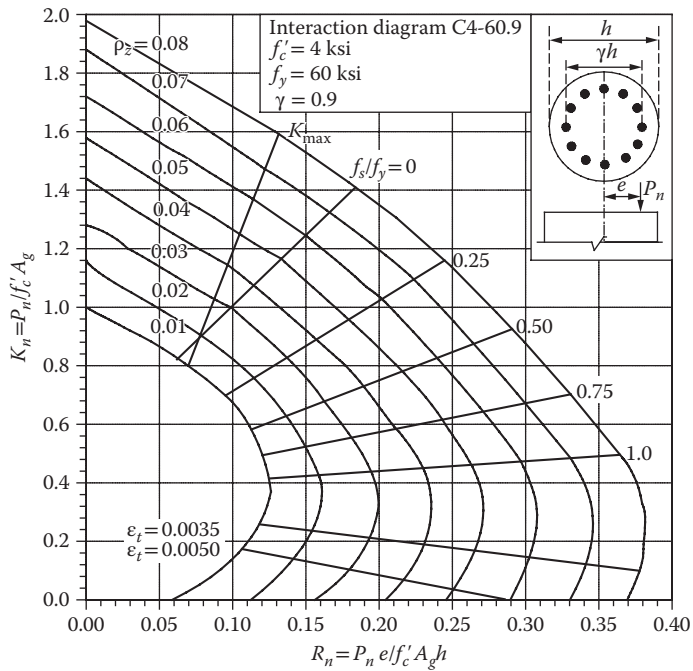


FIGURE D.22 Column interaction diagram for circular spiral column. (Courtesy of the American Concrete Institute, Farmington Hills, MI.)



SECOND EDITION

# Principles of STRUCTURAL DESIGN

## Wood, Steel, and Concrete

“...a valuable source that provides efficient and authoritative guidance for students learning the fundamentals of codes and standards in structural material design.”

—Dr. Peggi L. Clouston, University of Massachusetts, Amherst, USA

“From design loads determination and building codes, to various design philosophies, to load distribution and load paths, the student is given a road map for designing a structure that answers the common question of ‘where do I begin?’... It is concise and focuses on applications rather than extensive theoretical background and current research...”

—Caesar Abi Shdid, Ph.D., P.E., Lebanese American University, Beirut, Lebanon

A structural design book with a code-connected focus, *Principles of Structural Design: Wood, Steel, and Concrete, Second Edition* introduces the principles and practices of structural design. This book covers the section properties, design values, reference tables, and other design aids required to accomplish complete structural designs in accordance with the codes.

### *What's New in This Edition:*

- Reflects all the latest revised codes and standards
- The text material has been thoroughly reviewed and expanded, including a new chapter on concrete design
- Suitable for combined design coursework in wood, steel, and concrete
- Includes all essential material—the section properties, design values, reference tables, and other design aids required to accomplish complete structural designs according to the codes
- This book uses the LRFD basis of design for all structures

*Principles of Structural Design: Wood, Steel, and Concrete, Second Edition* was designed to be used for joint coursework in wood, steel, and concrete design.

K15209



